

Smart Highside High Current Power Switch Reversave™

Reversave™

- Reverse battery protection by self turn on of power MOSFET

Features

- Overload protection
- Current limitation
- Short circuit protection
- Overtemperature protection
- Overvoltage protection (including load dump)
- Clamp of negative voltage at output
- Fast deenergizing of inductive loads ²⁾
- Low ohmic inverse current operation
- Diagnostic feedback with load current sense
- Open load detection via current sense
- Loss of V_{bb} protection³⁾
- **Electrostatic discharge (ESD) protection**

Application

- Power switch with current sense diagnostic feedback for 12 V and 24 V DC grounded loads
- Most suitable for loads with high inrush current like lamps and motors; all types of resistive and inductive loads
- Replaces electromechanical relays, fuses and discrete circuits

General Description

N channel vertical power FET with charge pump, current controlled input and diagnostic feedback with load current sense, integrated in Smart SIPMOS® chip on chip technology. Providing embedded protective functions.

Product Summary

Overvoltage protection	$V_{bb(AZ)}$	62	V
Output clamp	$V_{ON(CL)}$	44	V
Operating voltage	$V_{bb(on)}$	5.0 ... 34	V
On-state resistance	$R_{ON}^{1)}$	2.5	mΩ
Load current (ISO)	$I_L(ISO)$	165	A
Short circuit current limitation	$I_L(SCp)$	520	A
Current sense ratio	$I_L : I_{IS}$	30 000	

TO-218AB/5

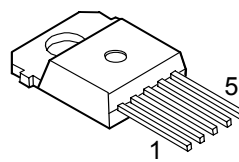

Straight leads

TO-218AB-5-1

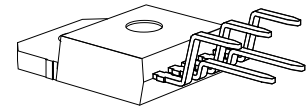

Staggered leads

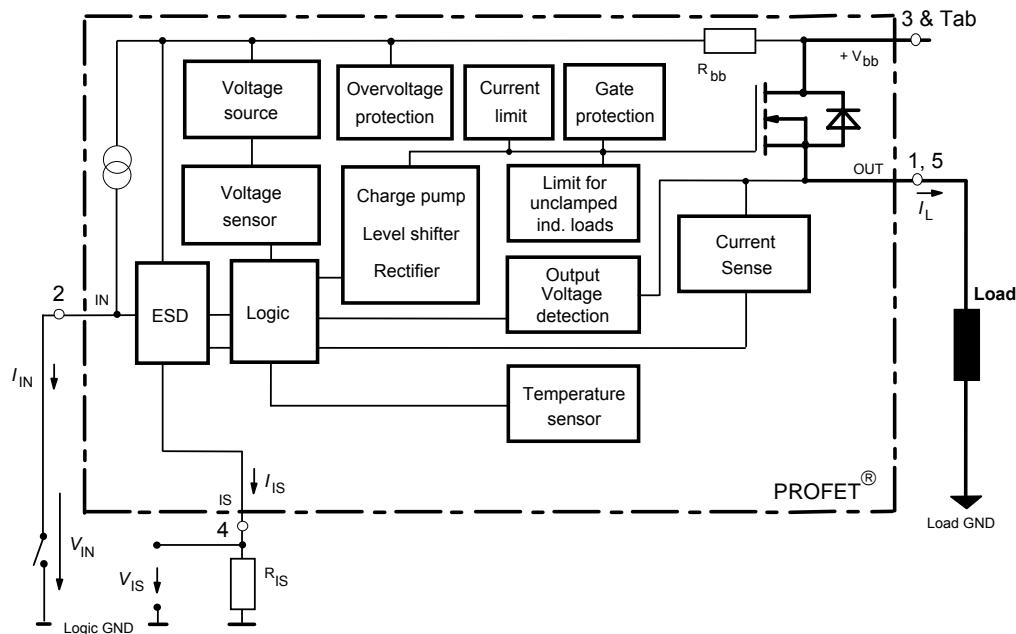

1) Due to the different lead frame geometry Ron @25°C is 0.3 mΩ higher in staggered than in straight version, and accordingly for other temperatures.
 2) With additional external diode.
 3) Additional external diode required for energized inductive loads (see page 9).

Pin	Symbol		Function
1	OUT	O	Output to the load. The pins 1 and 5 must be shorted with each other especially in high current applications! ⁴⁾
2	IN	I	Input, activates the power switch in case of short to ground
3	V _{bb}	+	Positive power supply voltage, the tab is electrically connected to this pin. In high current applications the tab should be used for the V _{bb} connection instead of this pin ⁵⁾ .
4	IS	S	Diagnostic feedback providing a sense current proportional to the load current; zero current on failure (see Truth Table on page 7)
5	OUT	O	Output to the load. The pins 1 and 5 must be shorted with each other especially in high current applications! ⁴⁾

Maximum Ratings at $T_j = 25\text{ °C}$ unless otherwise specified

Parameter	Symbol	Values	Unit
Supply voltage (overvoltage protection see page 4)	V _{bb}	40	V
Supply voltage for full short circuit protection, (E _{AS} limitation see diagram on page 9) $T_{j,start} = -40 \dots +150\text{ °C}$:	V _{bb}	34	V
Load current (short circuit current, see page 5)	I _L	self-limited	A
Load dump protection $V_{LoadDump} = U_A + V_s$, $U_A = 13.5\text{ V}$ $R_1^{6)} = 2\ \Omega$, $R_L = 0.1\ \Omega$, $t_d = 200\text{ ms}$, IN, IS = open or grounded	V _{Load dump} ⁷⁾	80	V
Operating temperature range	T _j	-40 ... +150	°C
Storage temperature range	T _{stg}	-55 ... +150	
Power dissipation (DC), T _C ≤ 25 °C	P _{tot}	360	W
Inductive load switch-off energy dissipation, single pulse V _{bb} = 12V, T _{j,start} = 150°C, T _C = 150°C const., I _L = 20 A, Z _L = 15 mH, 0 Ω, see diagrams on page 10	E _{AS}	3	J
Electrostatic discharge capability (ESD) Human Body Model acc. MIL-STD883D, method 3015.7 and ESD assn. std. S5.1-1993, C = 100 pF, R = 1.5 kΩ	V _{ESD}	4.0	kV
Current through input pin (DC)	I _{IN}	+15, -250	mA
Current through current sense status pin (DC) see internal circuit diagrams on page 7 and 8	I _{IS}	+15, -250	

4) Not shorting all outputs will considerably increase the on-state resistance, reduce the peak current capability and decrease the current sense accuracy

5) Otherwise add up to 0.5 mΩ (depending on used length of the pin) to the R_{ON} if the pin is used instead of the tab.

6) R₁ = internal resistance of the load dump test pulse generator.

7) V_{Load dump} is setup without the DUT connected to the generator per ISO 7637-1 and DIN 40839.



Thermal Characteristics

Parameter and Conditions	Symbol	Values			Unit
		min	typ	max	
Thermal resistance chip - case: junction - ambient (free air):	$R_{thJC}^{8)}$	--	--	0.35	K/W
	R_{thJA}	--	30	--	

Electrical Characteristics

Parameter and Conditions at $T_j = -40 \dots +150^\circ\text{C}$, $V_{bb} = 12\text{V}$ unless otherwise specified	Symbol	Values			Unit
		min	typ	max	

Load Switching Capabilities and Characteristics

On-state resistance (Tab to pins 1,5, see measurement circuit page 7) $I_L = 30\text{A}$, $T_j = 25^\circ\text{C}$: $V_{IN} = 0$, $I_L = 30\text{A}$, $T_j = 150^\circ\text{C}$: $I_L = 120\text{A}$, $T_j = 150^\circ\text{C}$: $V_{bb} = 6\text{V}^9)$, $I_L = 20\text{A}$, $T_j = 150^\circ\text{C}$:	$R_{ON}^{1)}$	--	1.9	2.5	m Ω	
		--	3.3	4.0		
		--	--	4.0		
	$R_{ON(Static)}^{1)}$	--	4.6	9.0		
Nominal load current ¹⁰⁾ (Tab to pins 1,5) ISO 10483-1/6.7: $V_{ON} = 0.5\text{V}$, $T_C = 85^\circ\text{C}$ ¹¹⁾	$I_{L(ISO)}$	128	165	--	A	
Maximum load current in resistive range (Tab to pins 1,5) see diagram on page 13	$I_{L(Max)}$	$V_{ON} = 1.8\text{V}$, $T_C = 25^\circ\text{C}$:	520	--	--	A
		$V_{ON} = 1.8\text{V}$, $T_C = 150^\circ\text{C}$:	360	--	--	
Turn-on time ¹²⁾ I_{IN}  to 90% V_{OUT} :	t_{on}	120	--	600	μs	
Turn-off time I_{IN}  to 10% V_{OUT} : $R_L = 1\Omega$, $T_j = -40\dots+150^\circ\text{C}$	t_{off}	50	--	200		
Slew rate on ¹²⁾ (10 to 30% V_{OUT}) $R_L = 1\Omega$	dV/dt_{on}	0.3	0.5	0.8	V/ μs	
Slew rate off ¹²⁾ (70 to 40% V_{OUT}) $R_L = 1\Omega$	$-dV/dt_{off}$	0.3	0.7	1	V/ μs	

8) Thermal resistance R_{thCH} case to heatsink (about 0.25 K/W with silicone paste) not included!

9) Decrease of V_{bb} below 10 V causes slowly a dynamic increase of R_{ON} to a higher value of $R_{ON(Static)}$. As long as $V_{bIN} > V_{bIN(u) max}$, R_{ON} increase is less than 10 % per second for $T_j < 85^\circ\text{C}$.

10) not subject to production test, specified by design

11) T_j is about 105°C under these conditions.

12) See timing diagram on page 14.

Parameter and Conditions at $T_j = -40 \dots +150^\circ\text{C}$, $V_{bb} = 12\text{V}$ unless otherwise specified	Symbol	Values			Unit
		min	typ	max	

Inverse Load Current Operation

On-state resistance (Pins 1,5 to pin 3) $V_{bIN} = 12\text{V}$, $I_L = -30\text{A}$ see diagram on page 10	$T_j = 25^\circ\text{C}$: $T_j = 150^\circ\text{C}$:	$R_{ON(inv)}^{1)}$	--	1.9 3.3	2.5 4.0	$\text{m}\Omega$
Nominal inverse load current (Pins 1,5 to Tab) $V_{ON} = -0.5\text{V}$, $T_C = 85^\circ\text{C}^{11}$		$I_{L(inv)}$	128	165	--	A
Drain-source diode voltage ($V_{out} > V_{bb}$) $I_L = -20\text{A}$, $I_{IN} = 0$, $T_j = +150^\circ\text{C}$		$-V_{ON}$	--	0.6	0.7	V

Operating Parameters

Operating voltage ($V_{IN} = 0$) ¹³⁾		$V_{bb(on)}$	5.0	--	34	V
Undervoltage shutdown ¹⁴⁾		$V_{bIN(u)}$	1.5	3.0	4.5	V
Undervoltage start of charge pump see diagram page 15		$V_{bIN(ucp)}$	3.0	4.5	6.0	V
Oversvoltage protection ¹⁵⁾ $I_{bb} = 15\text{mA}$	$T_j = -40^\circ\text{C}$: $T_j = 25\dots+150^\circ\text{C}$:	$V_{bIN(z)}$	60 62	-- 66	-- --	V
Standby current $I_{IN} = 0$	$T_j = -40\dots+25^\circ\text{C}$: $T_j = 150^\circ\text{C}$:	$I_{bb(off)}$	-- --	15 25	25 50	μA

¹³⁾ If the device is turned on before a V_{bb} -decrease, the operating voltage range is extended down to $V_{bIN(u)}$. For the voltage range 0..34 V the device is fully protected against overtemperature and short circuit.

¹⁴⁾ $V_{bIN} = V_{bb} - V_{IN}$ see diagram on page 7. When V_{bIN} increases from less than $V_{bIN(u)}$ up to $V_{bIN(ucp)} = 5\text{V}$ (typ.) the charge pump is not active and $V_{OUT} \approx V_{bb} - 3\text{V}$.

¹⁵⁾ See also $V_{ON(CL)}$ in circuit diagram on page 8.

Parameter and Conditions at $T_j = -40 \dots +150^\circ\text{C}$, $V_{bb} = 12\text{V}$ unless otherwise specified	Symbol	Values			Unit
		min	typ	max	

Protection Functions¹⁶⁾

Short circuit current limit (Tab to pins 1,5) ¹⁷⁾ $V_{ON} = 12\text{V}$, time until shutdown max. $300\ \mu\text{s}$ $T_c = -40^\circ\text{C}$: $T_c = 25^\circ\text{C}$: $T_c = +150^\circ\text{C}$:	$I_{L(SCP)}$	200 200 300	320 400 480	550 620 650	A
Short circuit shutdown delay after input current positive slope, $V_{ON} > V_{ON(SC)}$ min. value valid only if input "off-signal" time exceeds $30\ \mu\text{s}$	$t_{d(SC)}$	80	--	300	μs
Output clamp ¹⁸⁾ (inductive load switch off) $I_L = 40\ \text{mA}$:	$-V_{OUT(CL)}$	14	17	20	V
Output clamp (inductive load switch off) at $V_{OUT} = V_{bb} - V_{ON(CL)}$ (e.g. overvoltage) $I_L = 40\ \text{mA}$	$V_{ON(CL)}$	40	44	47	V
Short circuit shutdown detection voltage (pin 3 to pins 1,5)	$V_{ON(SC)}$	--	6	--	V
Thermal overload trip temperature	T_{jt}	150	--	--	$^\circ\text{C}$
Thermal hysteresis	ΔT_{jt}	--	10	--	K

Reverse Battery

Reverse battery voltage ¹⁹⁾	$-V_{bb}$	--	--	16	V
On-state resistance (Pins 1,5 to pin 3) $V_{bb} = -12\text{V}$, $V_{IN} = 0$, $I_L = -30\ \text{A}$, $R_{IS} = 1\ \text{k}\Omega$	$R_{ON(rev)}^{1)}$	--	2.3 3.9	3.0 4.7	$\text{m}\Omega$
Integrated resistor in V_{bb} line	R_{bb}	90 105	110 125	135 150	Ω

¹⁶⁾ Integrated protection functions are designed to prevent IC destruction under fault conditions described in the data sheet. Fault conditions are considered as "outside" normal operating range. Protection functions are not designed for continuous repetitive operation.

¹⁷⁾ Short circuit is a failure mode. The device is not designed to operate continuously into a short circuit by permanent resetting the short circuit latch function. The lifetime will be reduced under such conditions.

¹⁸⁾ This output clamp can be "switched off" by using an additional diode at the IS-Pin (see page 8). If the diode is used, V_{OUT} is clamped to $V_{bb} - V_{ON(CL)}$ at inductive load switch off.

¹⁹⁾ The reverse load current through the intrinsic drain-source diode has to be limited by the connected load (as it is done with all polarity symmetric loads). Note that under off-conditions ($I_{IN} = I_{IS} = 0$) the power transistor is not activated. This results in raised power dissipation due to the higher voltage drop across the intrinsic drain-source diode. The temperature protection is not active during reverse current operation! Increasing reverse battery voltage capability is simply possible as described on page 9.

Parameter and Conditions at $T_j = -40 \dots +150^\circ\text{C}$, $V_{bb} = 12\text{V}$ unless otherwise specified	Symbol	Values			Unit
		min	typ	max	

Diagnostic Characteristics

Current sense ratio, static on-condition, $k_{ILIS} = I_L : I_{IS}$, $V_{ON} < 1.5\text{V}^{20}$, $V_{IS} < V_{OUT} - 5\text{V}$, $V_{bIN} > 4.0\text{V}$ (see diagram on page 10)	$I_L = 120\text{A}$, $T_j = -40^\circ\text{C}$: $T_j = 25^\circ\text{C}$: $T_j = 150^\circ\text{C}$:	k_{ILIS}	25 000	29 000	34 000	
	$I_L = 30\text{A}$, $T_j = -40^\circ\text{C}$: $T_j = 25^\circ\text{C}$: $T_j = 150^\circ\text{C}$:		26 000	28 500	32 000	
	$I_L = 16\text{A}$, $T_j = -40^\circ\text{C}$: $T_j = 25^\circ\text{C}$: $T_j = 150^\circ\text{C}$:		24 000	26 500	29 000	
	$I_L = 12\text{A}$, $T_j = -40^\circ\text{C}$: $T_j = 25^\circ\text{C}$: $T_j = 150^\circ\text{C}$:		25 000	31 200	40 000	
			25 000	30 200	35 000	
			23 000	27 200	31 500	
			24 000	33 500	48 000	
			24 000	31 500	40 000	
			23 000	27 500	32 000	
			23 000	40 500	61 000	
			23 000	40 500	45 000	
			23 000	29 000	34 000	
$I_{IS} = 0$ by $I_{IN} = 0$ (e.g. during deenergizing of inductive loads):						
Sense current saturation	$I_{IS,lim}$	6.5	--	--	mA	
Current sense leakage current	$I_{IN} = 0$, $V_{IS} = 0$:	$I_{IS(LL)}$	--	--	0.5 μA	
	$V_{IN} = 0$, $V_{IS} = 0$, $I_L \leq 0$:	$I_{IS(LH)}$	--	2	--	
Current sense settling time ²¹⁾	$t_{s(IS)}$	--	--	500	μs	
Overvoltage protection $I_{bb} = 15\text{mA}$	$T_j = -40^\circ\text{C}$:	$V_{bIS(Z)}$	60	--	--	V
	$T_j = 25\dots+150^\circ\text{C}$:		62	66	--	

Input

Input and operating current (see diagram page 13) IN grounded ($V_{IN} = 0$)	$I_{IN(on)}$	--	0.8	1.5	mA
Input current for turn-off ²²⁾	$I_{IN(off)}$	--	--	40	μA

²⁰⁾ If V_{ON} is higher, the sense current is no longer proportional to the load current due to sense current saturation, see $I_{IS,lim}$.

²¹⁾ not subject to production test, specified by design

²²⁾ We recommend the resistance between IN and GND to be less than 0.5 k Ω for turn-on and more than 500k Ω for turn-off. Consider that when the device is switched off ($I_{IN} = 0$) the voltage between IN and GND reaches almost V_{bb} .

Truth Table

	Input current level	Output level	Current Sense I_{IS}	Remark
Normal operation	L H	L H	0 nominal	$=I_L / k_{IIS}$, up to $I_{IS}=I_{IS,lim}$
Very high load current	H	H	$I_{IS, lim}$	up to $V_{ON}=V_{ON(Fold\ back)}$ I_{IS} no longer proportional to I_L
Current-limitation	H	H	0	$V_{ON} > V_{ON(Fold\ back)}$ if $V_{ON}>V_{ON(SC)}$, shutdown will occur
Short circuit to GND	L H	L L	0 0	
Over-temperature	L H	L L	0 0	
Short circuit to V_{bb}	L H	H H	0 <nominal ²³⁾	
Open load	L H	Z ²⁴⁾ H	0 0	
Negative output voltage clamp	L	L	0	
Inverse load current	L H	H H	0 0	

L = "Low" Level
H = "High" Level

Overtemperature reset via input: I_{IN} =low and $T_j < T_{jt}$ (see diagram on page14)

Short circuit to GND: Shutdown remains latched until next reset via input (see diagram on page 14)

Terms

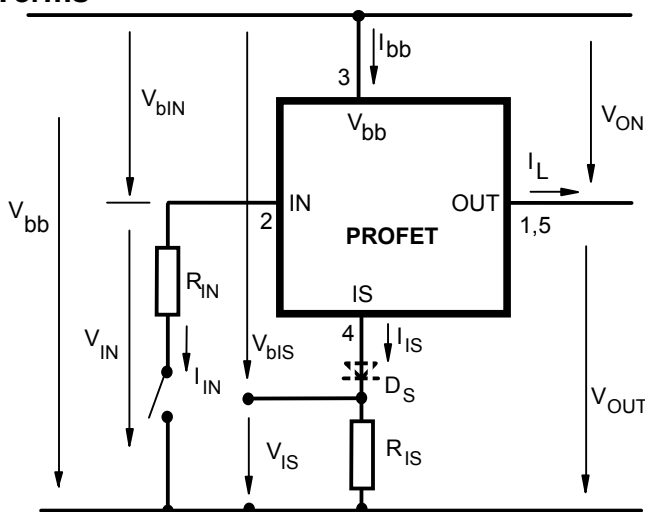

Two or more devices can easily be connected in parallel to increase load current capability.

R_{ON} measurement layout (straight leads)

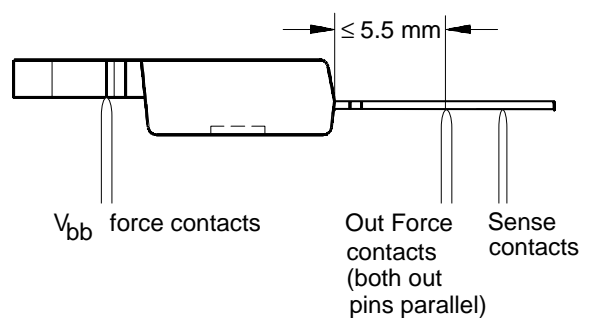

23) Low ohmic short to V_{bb} may reduce the output current I_L and can thus be detected via the sense current I_{IS} .
24) Power Transistor "OFF", potential defined by external impedance.

Input circuit (ESD protection)

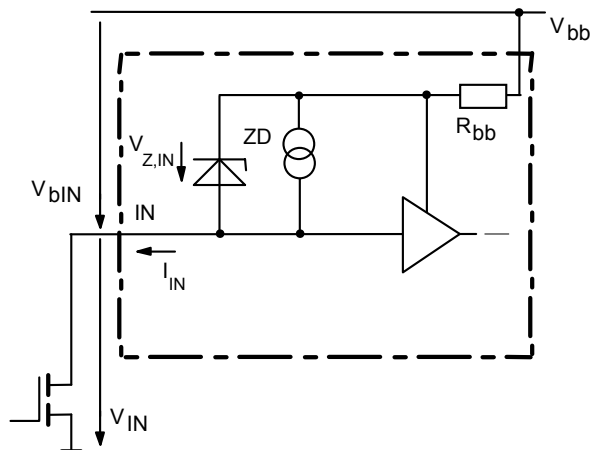

When the device is switched off ($I_{IN} = 0$) the voltage between IN and GND reaches almost V_{bb} . Use a mechanical switch, a bipolar or MOS transistor with appropriate breakdown voltage as driver.
 $V_{Z,IN} = 66\text{ V (typ.)}$.

Current sense status output

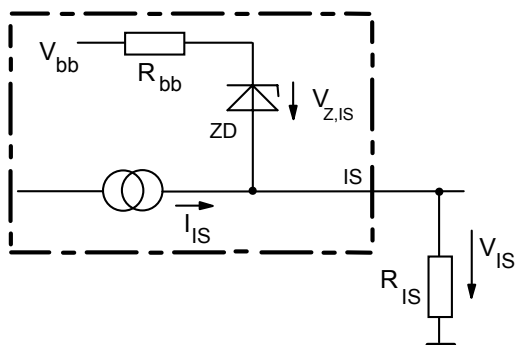

$V_{Z,IS} = 66\text{ V (typ.)}$, $R_{IS} = 1\text{ k}\Omega$ nominal (or $1\text{ k}\Omega / n$, if n devices are connected in parallel). $I_S = I_L / K_{iIS}$ can be only driven by the internal circuit as long as $V_{out} - V_{IS} > 5\text{ V}$. If you want to measure load currents up to $I_{L(M)}$, R_{IS} should be less than $\frac{V_{bb} - 5\text{ V}}{I_{L(M)} / K_{iIS}}$.

Note: For large values of R_{IS} the voltage V_{IS} can reach almost V_{bb} . See also overvoltage protection. If you don't use the current sense output in your application, you can leave it open.

Short circuit detection

Fault Condition: $V_{ON} > V_{ON(SC)}$ (6 V typ.) and $t > t_{d(SC)}$ ($80 \dots 300\ \mu\text{s}$).

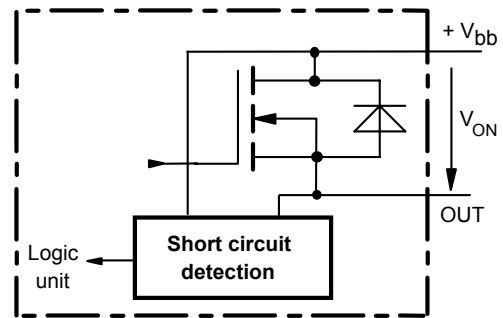

Inductive and overvoltage output clamp

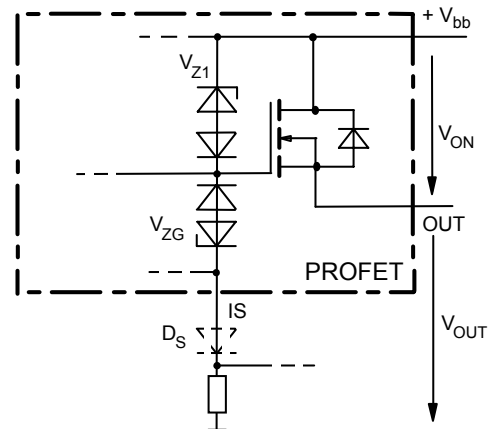

V_{ON} is clamped to $V_{ON(CL)} = 42\text{ V typ.}$ At inductive load switch-off without D_S , V_{OUT} is clamped to $V_{OUT(CL)} = -17\text{ V typ.}$ via V_{ZG} . With D_S , V_{OUT} is clamped to $V_{bb} - V_{ON(CL)}$ via V_{Z1} . Using D_S gives faster deenergizing of the inductive load, but higher peak power dissipation in the PROFET. In case of a floating ground with a potential higher than 19 V referring to the OUT – potential the device will switch on, if diode D_S is not used.

Overvoltage protection of logic part

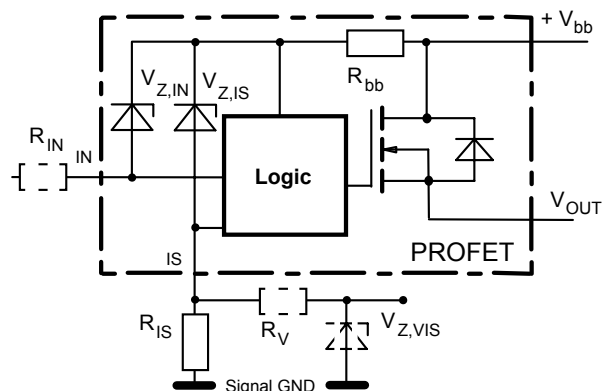

$R_{bb} = 120\ \Omega$ typ., $V_{Z,IN} = V_{Z,IS} = 66\text{ V typ.}$, $R_{IS} = 1\text{ k}\Omega$ nominal. Note that when overvoltage exceeds 71 V typ. a voltage above 5 V can occur between IS and GND, if R_V , $V_{Z,VIS}$ are not used.

Reverse battery protection

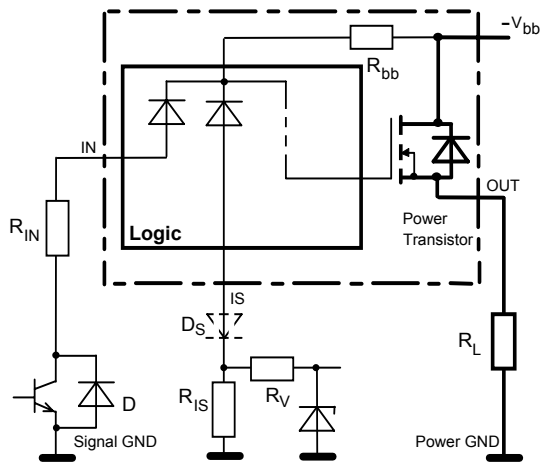

$R_V \geq 1\text{ k}\Omega$, $R_{IS} = 1\text{ k}\Omega$ nominal. Add R_{IN} for reverse battery protection in applications with V_{bb} above $16\text{ V}^{19)}$; recommended value: $\frac{1}{R_{IN}} + \frac{1}{R_{IS}} + \frac{1}{R_V} = \frac{0.1\text{ A}}{|V_{bb}| - 12\text{ V}}$ if D_S is not used (or $\frac{1}{R_{IN}} = \frac{0.1\text{ A}}{|V_{bb}| - 12\text{ V}}$ if D_S is used).

To minimize power dissipation at reverse battery operation, the summarized current into the IN and IS pin should be about 120mA. The current can be provided by using a small signal diode D in parallel to the input switch, by using a MOSFET input switch or by proper adjusting the current through R_{IS} and R_V .

V_{bb} disconnect with energized inductive load

Provide a current path with load current capability by using a diode, a Z-diode, or a varistor. ($V_{ZL} < 72\text{ V}$ or $V_{Zb} < 30\text{ V}$ if $R_{IN}=0$). For higher clamp voltages currents at IN and IS have to be limited to 250 mA.

Version a:

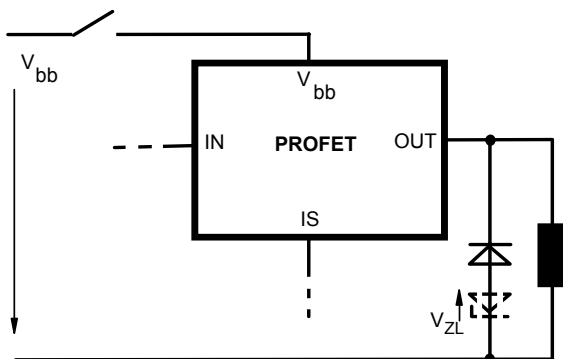

Version b:

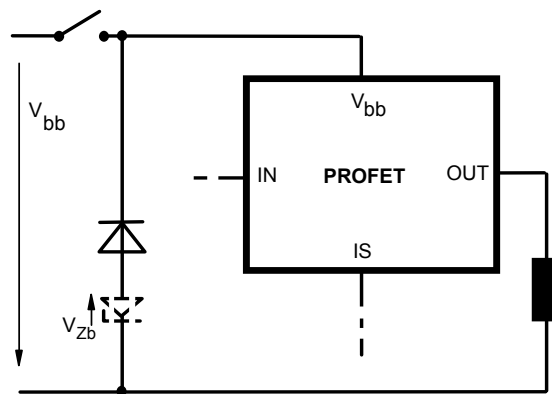

Note that there is no reverse battery protection when using a diode without additional Z-diode V_{ZL} , V_{Zb} .

Version c: Sometimes a necessary voltage clamp is given by non inductive loads R_L connected to the same switch and eliminates the need of clamping circuit:

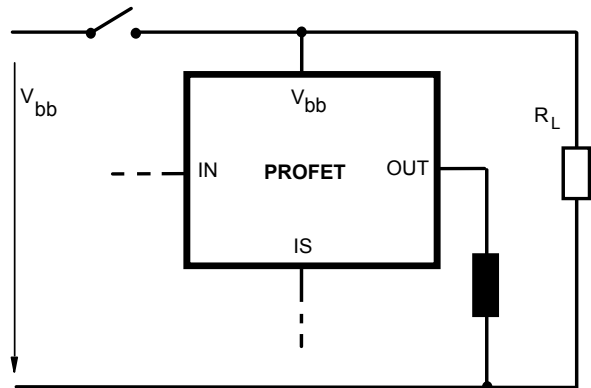

Inverse load current operation

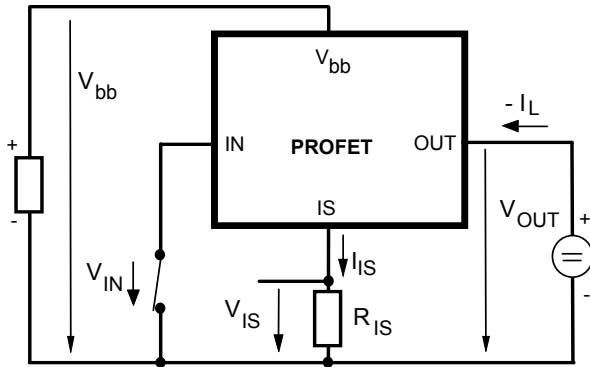

The device is specified for inverse load current operation ($V_{OUT} > V_{bb} > 0V$). The current sense feature is not available during this kind of operation ($I_S = 0$). With $I_{IN} = 0$ (e.g. input open) only the intrinsic drain source diode is conducting resulting in considerably increased power dissipation. If the device is switched on ($V_{IN} = 0$), this power dissipation is decreased to the much lower value $R_{ON(INV)} \cdot I^2$ (specifications see page 4).

Note: Temperature protection during inverse load current operation is not possible!

Inductive load switch-off energy dissipation

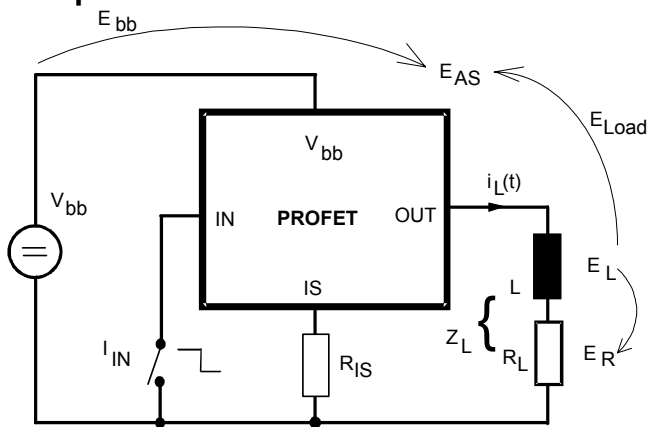

Energy stored in load inductance:

$$E_L = 1/2 \cdot L \cdot I_L^2$$

While demagnetizing load inductance, the energy dissipated in PROFET is

$$E_{AS} = E_{bb} + E_L - E_R = \int V_{ON(CL)} \cdot i_L(t) dt,$$

with an approximate solution for $R_L > 0 \Omega$:

$$E_{AS} = \frac{I_L \cdot L}{2 \cdot R_L} (V_{bb} + |V_{OUT(CL)}|) \ln \left(1 + \frac{I_L \cdot R_L}{|V_{OUT(CL)}|} \right)$$

Maximum allowable load inductance for a single switch off

$$L = f(I_L); T_{j,start} = 150^\circ C, V_{bb} = 12V, R_L = 0 \Omega$$

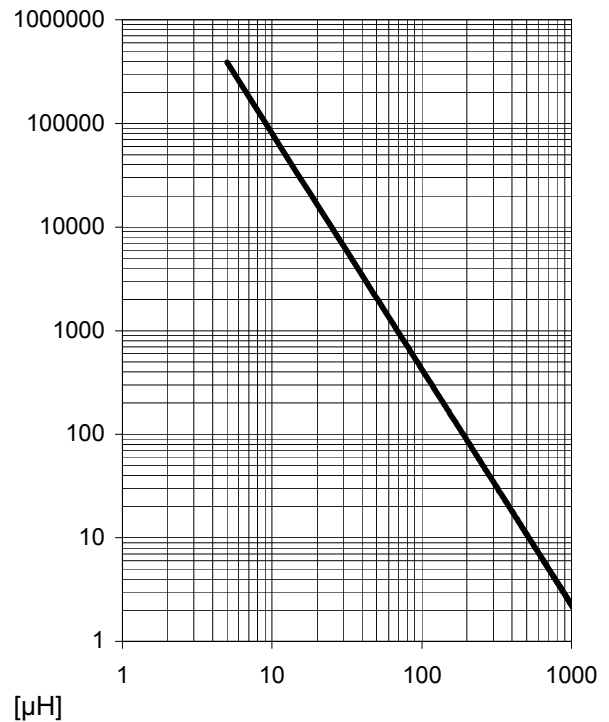

I_L [A]

Externally adjustable current limit

If the device is conducting, the sense current can be used to reduce the short circuit current and allow higher lead inductance (see diagram above). The device will be turned off, if the threshold voltage of T2 is reached by $I_S \cdot R_{IS}$. After a delay time defined by $R_V \cdot C_V$ T1 will be reset. The device is turned on again, the short circuit current is defined by $I_{L(SC)}$ and the device is shut down after $t_{d(SC)}$ with latch function.

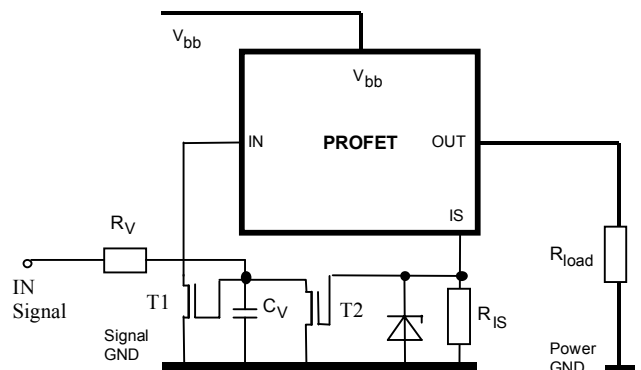

Options Overview

Type	BTS	6510	550P 650P	555
Overtemperature protection with hysteresis $T_j > 150\text{ °C}$, latch function ²⁵⁾		X	X	X
$T_j > 150\text{ °C}$, with auto-restart on cooling		X	X	
Short circuit to GND protection with overtemperature shutdown		X		
switches off when $V_{ON} > 6\text{ V}$ typ. (when first turned on after approx. 180 μs)			X	X
Overvoltage shutdown		-	-	-
Output negative voltage transient limit to $V_{bb} - V_{ON(CL)}$ to $V_{OUT} = -15\text{ V}$ typ		X X ²⁶⁾	X X ²⁶⁾	X X ²⁶⁾

²⁵⁾ Latch except when $V_{bb} - V_{OUT} < V_{ON(SC)}$ after shutdown. In most cases $V_{OUT} = 0\text{ V}$ after shutdown ($V_{OUT} \neq 0\text{ V}$ only if forced externally). So the device remains latched unless $V_{bb} < V_{ON(SC)}$ (see page 5). No latch between turn on and $t_{d(SC)}$.

²⁶⁾ Can be "switched off" by using a diode D_S (see page 8) or leaving open the current sense output.

Characteristics

Current sense versus load current:

$$I_S = f(I_L)$$

$$I_S \text{ [mA]}$$

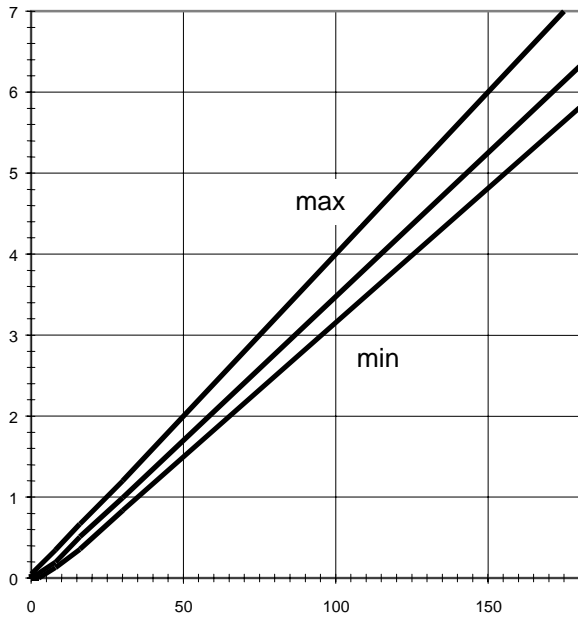

I_L [A]

Current sense ratio:

$$K_{ILIS} = f(I_L), T_J = 25 \text{ }^\circ\text{C}$$

$$k_{ILIS}$$

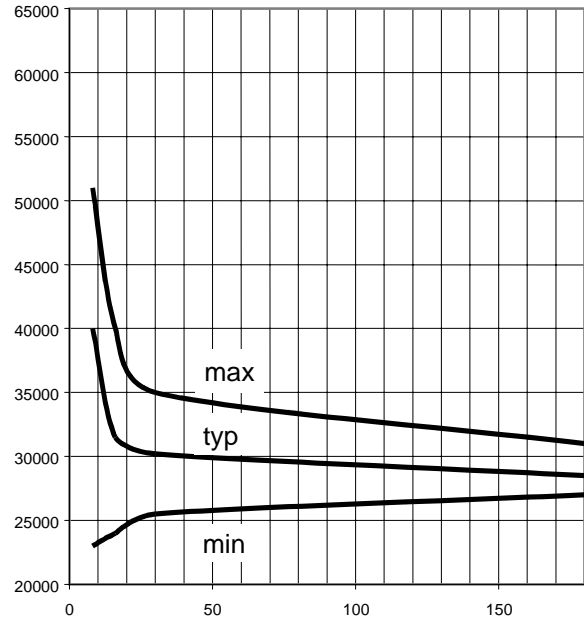

I_L [A]

Current sense ratio:

$$K_{ILIS} = f(I_L), T_J = -40 \text{ }^\circ\text{C}$$

$$k_{ILIS}$$

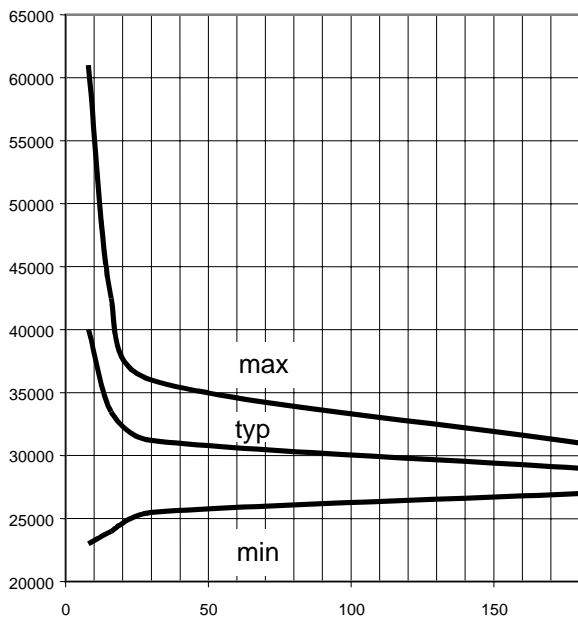

I_L [A]

Current sense ratio:

$$K_{ILIS} = f(I_L), T_J = 150 \text{ }^\circ\text{C}$$

$$k_{ILIS}$$

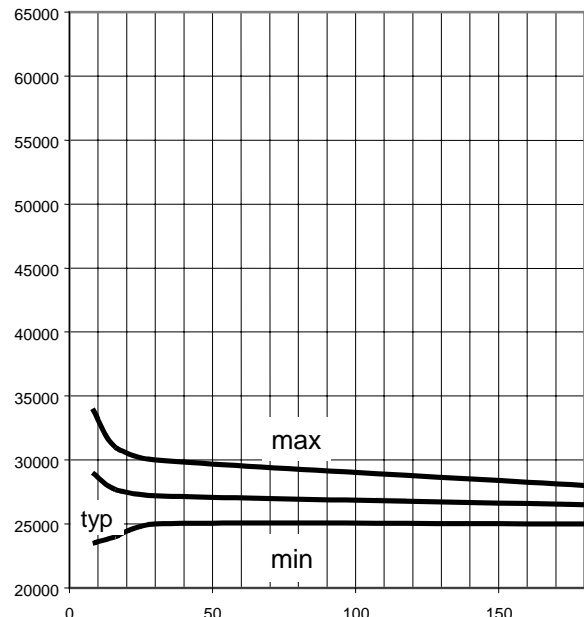

I_L [A]

Typ. current limitation characteristic

$I_L = f(V_{ON}, T_j)$

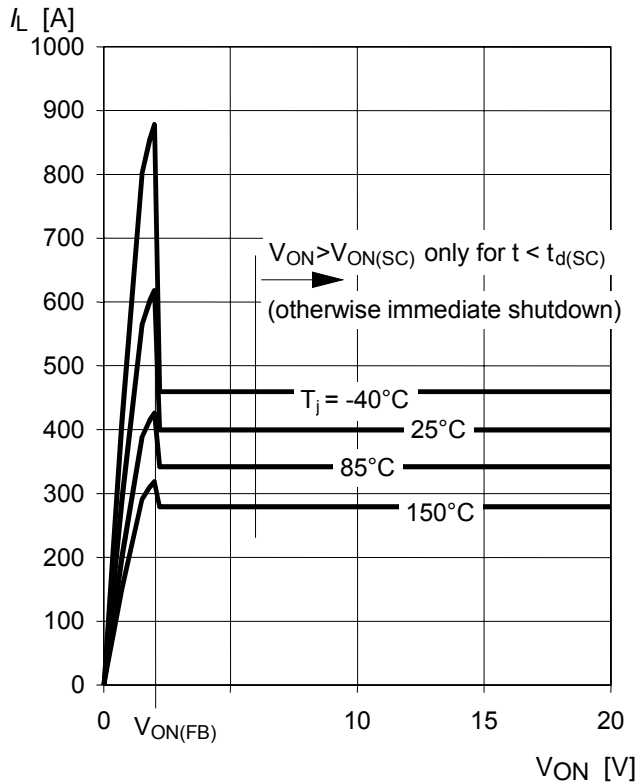

In case of $V_{ON} > V_{ON(SC)}$ (typ. 6 V) the device will be switched off by internal short circuit detection.

Typ. on-state resistance

$R_{ON} = f(V_{bb}, T_j); I_L = 30\text{ A}; V_{IN} = 0$

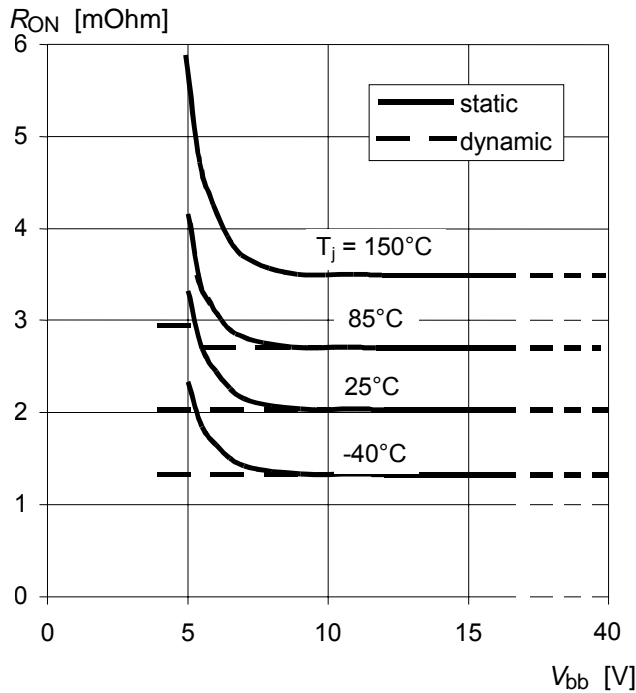

Typ. input current

$I_{IN} = f(V_{bIN}), V_{bIN} = V_{bb} - V_{IN}$

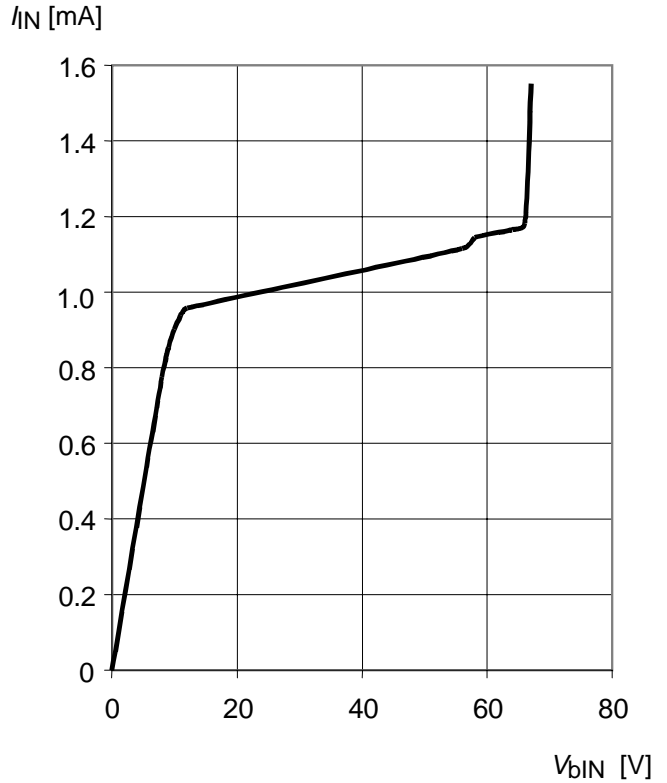

Timing diagrams

Figure 1a: Switching a resistive load, change of load current in on-condition:

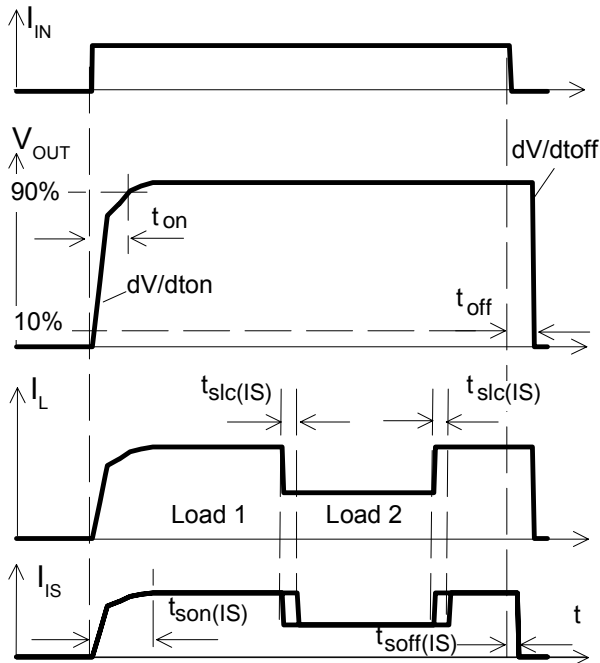

The sense signal is not valid during a settling time after turn-on/off and after change of load current.

Figure 2a: Switching motors and lamps:

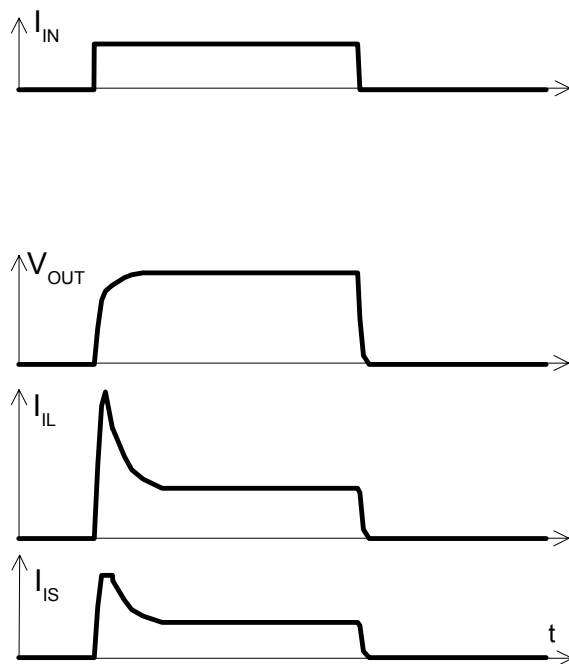

Sense current saturation can occur at very high inrush currents (see $I_{IS,lim}$ on page 6).

Figure 2b: Switching an inductive load:

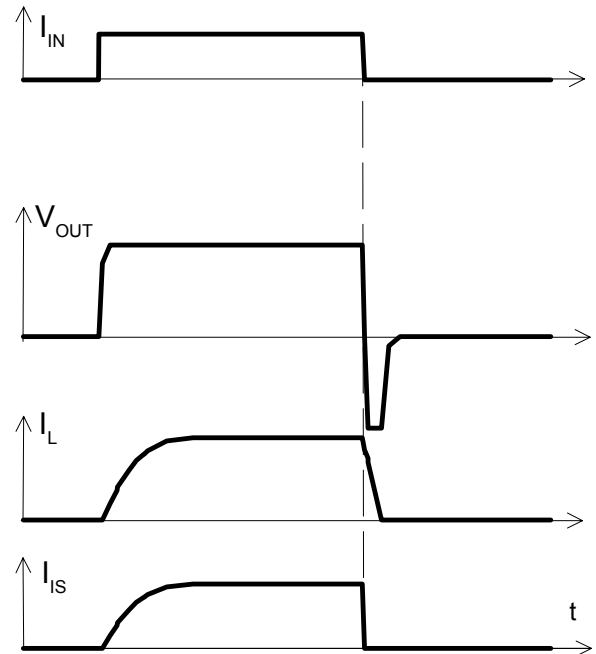
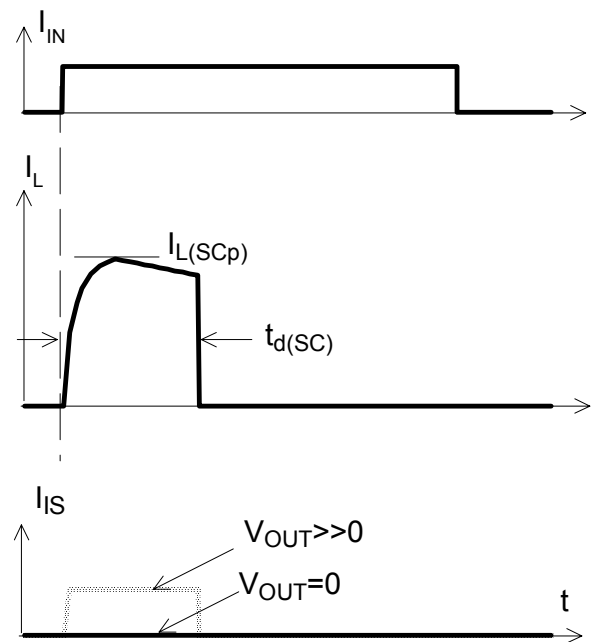

Figure 3a: Short circuit:

shut down by short circuit detection, reset by $I_{IN} = 0$.



Shut down remains latched until next reset via input.

Figure 4a: Overtemperature, Reset if (I_{IN} =low) and ($T_j < T_{jt}$)

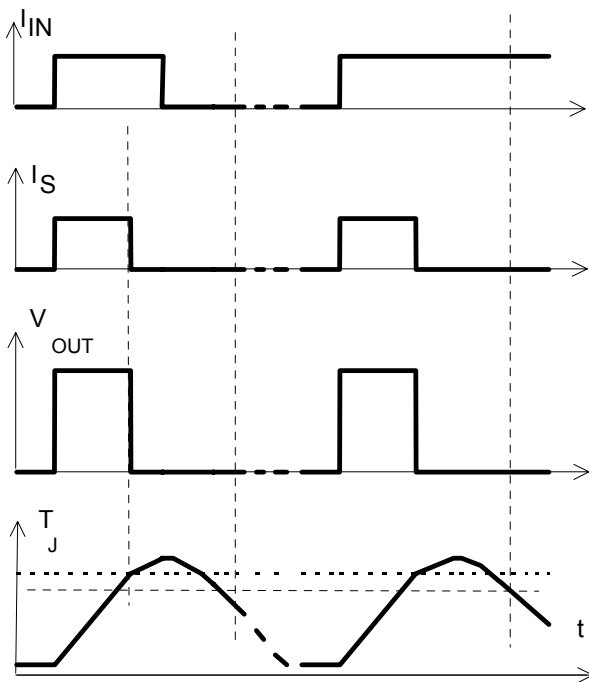
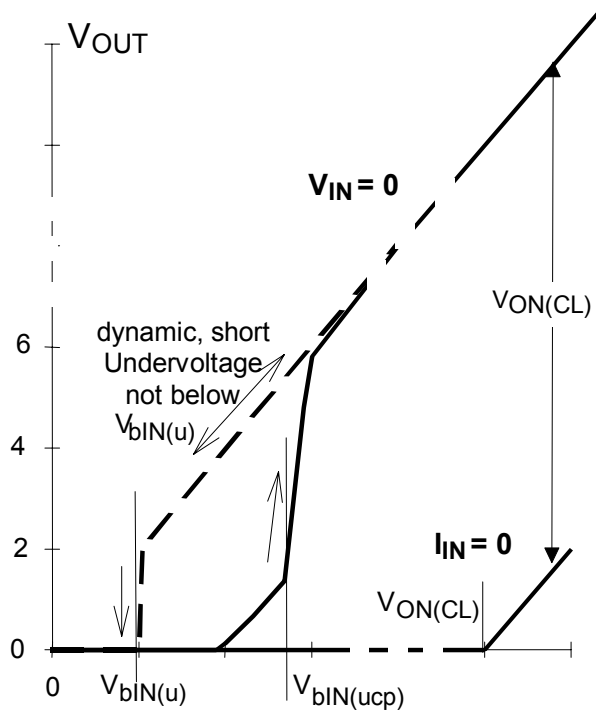

Figure 6a: Undervoltage restart of charge pump, overvoltage clamp



Package and Ordering Code

All dimensions in mm

TO-218AB/5 Option E3146 Ordering code

BTS555 E3146	Q67060-S6953A3
--------------	----------------

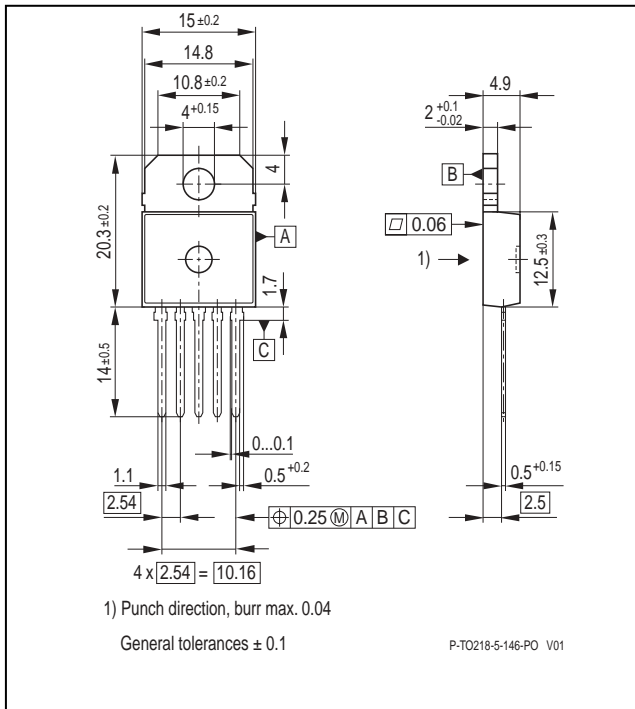

Revision History

Version	Changes
2008-June-24	Package drawings updated Revision history added Legal disclaimer updated

Edition 2008-06-24

**Published by
Infineon Technologies AG
81726 Munich, Germany**

**© 2008 Infineon Technologies AG.
All Rights Reserved.**

Legal Disclaimer

The information given in this document shall in no event be regarded as a guarantee of conditions or characteristics. With respect to any examples or hints given herein, any typical values stated herein and/or any information regarding the application of the device, Infineon Technologies hereby disclaims any and all warranties and liabilities of any kind, including without limitation, warranties of non-infringement of intellectual property rights of any third party.

Information

For further information on technology, delivery terms and conditions and prices please contact your nearest Infineon Technologies Office (www.infineon.com).

Warnings

Due to technical requirements components may contain dangerous substances. For information on the types in question please contact your nearest Infineon Technologies Office.

Infineon Technologies components may only be used in life-support devices or systems with the express written approval of Infineon Technologies, if a failure of such components can reasonably be expected to cause the failure of that life-support device or system, or to affect the safety or effectiveness of that device or system. Life support devices or systems are intended to be implanted in the human body or to support and/or maintain and sustain and/or protect human life. If they fail, it is reasonable to assume that the health of the user or other persons may be endangered.

TO-218AB/5-1

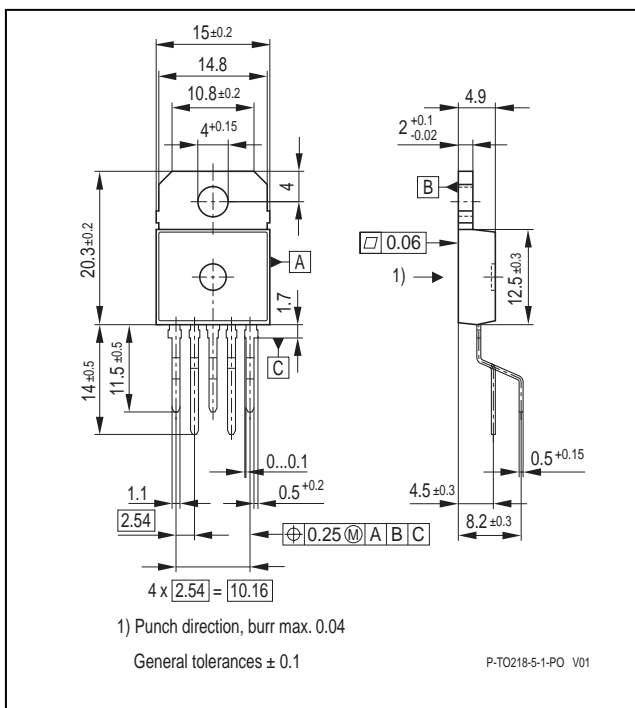

Ordering code

BTS555	Q67060-S6954
--------	--------------



Looking for pricing, stock, or lifecycle information?

Click below to explore more details on WIN SOURCE:

-  [View BTS555 E3146 on WIN SOURCE](#)
-  [Infineon Technologies Information](#)

Optimize Your Supply Chain with WIN SOURCE Solutions

-  Global Sourcing Solution
-  Obsolete Management
-  Cost Control Management
-  Shortage Management
-  Alternative Solution
-  Excess Inventory Management