



**THE DATASHEET OF  
MC33486DH**



*Advance Information*

# Dual High Side Switch for H-Bridge Automotive Applications

This device is a dual high side switch for automotive applications which incorporates a dual low side switch control feature. This device is designed to monitor two low side switches for typical DC-motor control in an H-Bridge configuration. It can be directly interfaced with a microcontroller for control and diagnostic functions, is PWM capable and has a self-adjusted switching speed for minimizing electromagnetic emission.

The High Side block incorporates two 15mΩ Rdson N-Channel power Mosfets with senses and a control circuitry. Each output of this high side block is protected against short to gnd and load shorts, and has over temperature detection with hysteresis. It includes a current recopy feature for monitoring the load current. The control circuitry also has an overvoltage detector which turns off the bridge and protects the load in case of Vbat exceeding 28V.

The low side control block is able to drive 2 low sides switches in a H-bridge configuration and protects them in case of short circuit. This, in combination with the High side protection, fully protects the H-bridge from shorted loads, shorts to Vbat and shorts to GND.

This device offers a very low quiescent current in standby mode.

- 10 Amps Nominal DC Current
- 35 Amps Maximum Peak Current
- DC Voltage from -0.3V to 40V
- Operating Voltage from 8 to 28V
- Overvoltage Detection : Switch Off when Vbat Exceed 28V
- High Side and Low Side Overcurrent protection
- Operating Junction Temperature - 40°C to 150°C
- Rdson 15mΩ max at 25C° per Mosfet
- DC to 30kHz PWM Capability
- Standby Mode with Low Standby Current
- Junction to Case Thermal Resistance : 2°C/W
- ESD protection 2kV
- Current Recopy to Monitor the High-Side Current
- Common diagnostic output

## MC33486

### DUAL HIGH SIDE SWITCH FOR H-BRIDGE AUTOMOTIVE APPLICATIONS

SEMICONDUCTOR TECHNICAL DATA

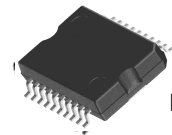

**DH SUFFIX**  
HSOP20 Package  
CASE 979-04



D²PAK D²PAK

#### PIN ASSIGNMENT

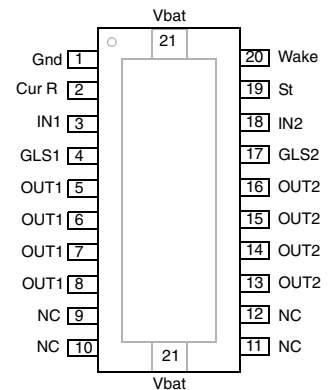

#### Simplified Block Diagram and Typical Application

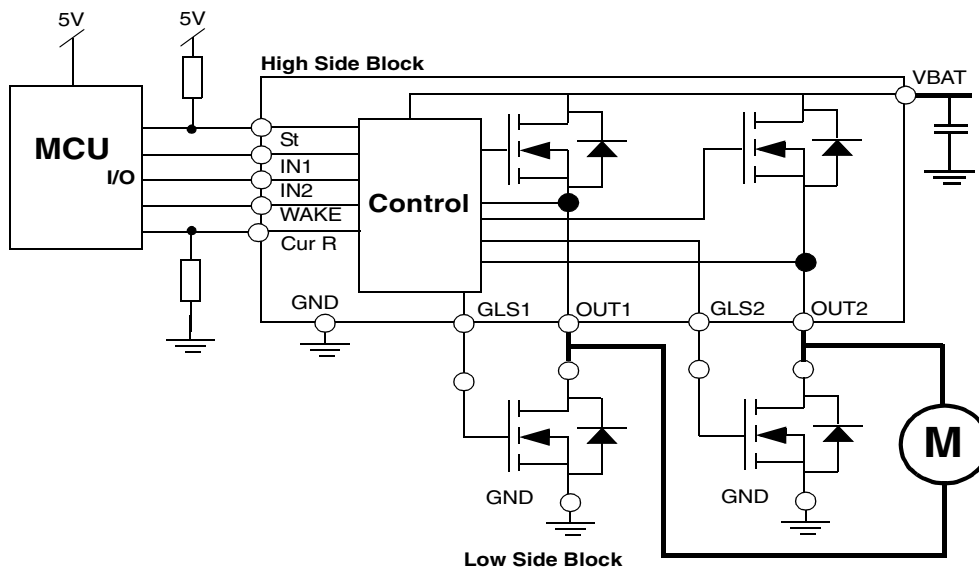

This document contains information on a new product. Specifications and information herein are subject to change without notice.

MC33486  
**Freescale Semiconductor, Inc.**  
**PINS FUNCTION DESCRIPTION**

Pin No.	Name/Function	Description
TAB	V <sub>bat</sub> Supply Voltage	The backside TAB is connected to the power supply of the MC33486DH. In addition to its supply function, the tab contributes to the thermal behaviour of the device by conducting the heat from the switching MOSFET to the printed circuit board.
5,6,7,8 13,14,15,16	OUT1 OUTPUT Channel 1 OUT 2 OUTPUT Channel 2	Pins 5, 6,7,8 are the source of the output1 15mOhm High-side MOSFET1. Pins 13,14,15 are source of the output 2 15mOhm High-side MOSFET2. They are respectively controlled via the IN1 and IN2 pins. These outputs are current limited and thermally protected
3 18	IN 1 INPUT Channel 1 IN 2 INPUT Channel 2	These are the device input pins which directly control their associated outputs. The levels are CMOS compatible. When the input is a logic low, the associated output is low (High Side OFF and Low Side ON). Each input pin has an internal active pull down, so that it will not float if disconnected.
19	St Status for both Channels	The Status output is an open drain indication that goes active low when a fault mode (Short to gnd/Vbat, Overtemp) is detected by the device on either one channel or both simultaneously. Its internal structure is an open drain architecture with an internal clamp at 6V. An external pull up resistor connected to Vdd (5V) is needed. See Functional Truth Table.
4 17	GLS1 GLS2	These pins have to be connected to the gate of each Low Side. When the input (INx) is logic High, the associated GLS is grounded to turn off the external FET .
20	Wake	This pin is a digital input . When Wake is a logic low, the device's bias current draw is at a minimum. If Wake is a logic high, the part is operational. Wake pin has a pull down resistor.
2	Cur R Load Current Sense	The Current Sense pin deliver a ratioed amount (1/3700) of the sum of the High Side currents that can be used to generate signal ground referenced output voltages for use by the microcontroller.
9, 10, 11, 12,	NC Not Connected	These pins are not used.
1	GND GROUND	This is the Ground pin of the device.

Freescale Semiconductor, Inc.

**MAXIMUM RATINGS**

Parameter	Symbol	Value	Unit
Power Supply Voltage : Continuous/ Pulse	Vbat	- 0.3 to + 40	V
Out1, Out2 to Vbat voltage : Continuous/ Pulse	Vout	- 0.3 to + 40	V
IN1, IN2, Wake, ST Input DC voltage : Continuous/ Pulse	Vin	-0.3 to + 7	V
IN1, IN2, Wake Input Current	Iin	+/- 5	mA
ESD all Pins Human Body Model (note1)	V <sub>esd1</sub>	+/-2000	V
Machine Model (note2)	V <sub>esd2</sub>	+/-200	V
Output DC Output Current, 1 Channel ON, Ta=85°C (note4)	I <sub>outdc</sub>	10	A
Output Current : Pulse (Note 3)	I <sub>outp</sub>	35	A

**THERMAL RATINGS**

Parameter	Symbol	Value	Unit
Junction Temperature	T <sub>j</sub>	- 40 to +150	°C
Storage Temperature Range	T <sub>st</sub>	- 65 to +150	°C
Thermal resistance junction to case	R <sub>thjc</sub>	2	°C/W
Thermal resistance junction to ambient (Note 4)	R <sub>thja</sub>	25	°C/W
Power dissipation at T <sub>case</sub> 140°C (Note 5)	P <sub>d</sub>	5	W

**NOTES :**

- ESD1 testing is performed in accordance with the Human Body Model (Czap = 100pF, Rzap = 1500Ω)
- ESD2 testing is performed in accordance with the Machine Model (Czap = 100pF, Rzap = 0Ω)
- During load in rush current.
- Device mounted on dual side printed circuit board with 70μm copper thickness and 10cm<sup>2</sup> copper heat sink (2.5 cm<sup>2</sup> on top side and 7.5 cm<sup>2</sup> on down side).
- Assuming a 150°C maximum junction temperature.

**ELECTRICAL CHARACTERISTICS High Side Block**

T<sub>j</sub> from - 40°C to +150°C, V<sub>bat</sub> from 9V to 16V, unless otherwise noted. Typical values reflect approximate mean at 25°C, nominal V<sub>bat</sub>, at time of device characterization.

Description	Symbol	Characteristics			Unit	Conditions
		Min.	Typ.	Max.		
<b>SUPPLY CHARACTERISTICS</b>						
Nominal Operating Voltage	V <sub>bat</sub>	8		28	V	Functional to truth table until overvoltage threshold
Standby Current	I <sub>stdby</sub>			10	μA	V <sub>bat</sub> < 13.5V, wake=0, IN1=IN2=0
Supply Current in Operation Mode	I <sub>on</sub>		9	15	mA	No PWM, IN1 or IN2=5V, Wake=5V
Supply Current in Operation Mode	I <sub>tbd</sub>		15		mA	PWM=20kHz, d=50%
<b>STATIC OUTPUT CHARACTERISTICS</b>						
High Side Drain to Source On Resistance	R <sub>dson</sub>		12	15	mΩ	I <sub>out</sub> = 5A, T <sub>j</sub> = 25°C
High Side Drain to Source On Resistance	R <sub>dson</sub>		21	30	mΩ	I <sub>out</sub> = 5A, V <sub>bat</sub> > 9V & T <sub>j</sub> = 150°C
High Side Body Diode Voltage (Out to Vbat)	V <sub>bd</sub>			0.7	V	@ I <sub>out</sub> = -5A, T <sub>j</sub> = 150°C
Low Side Gate output Voltage	V <sub>gs</sub>			14	V	Internally clamped

Description	Symbol	Characteristics			Unit	Conditions
		Min.	Typ.	Max.		
<b>INPUTS CHARACTERISTICS IN1, IN2, Wake</b>						
Input low levels	Vil			1.5	V	
Input high levels	Vih	3.5			V	
Input Hysteresis	Vhyst	0.2	0.6	1	V	IN1 and IN2 pins only
Logic Input Current	lin	1			μA	Vin = 1.5V
Logic Input Current	lin			50	μA	Vin = 3.5V
<b>STATUS CHARACTERISTICS</b>						
Status Voltage	Vst			0.5	V	Ist=1mA, output in fault
Status Leakage	Istlk			10	μA	Vst=5V
<b>OVERLOAD PROTECTION CHARACTERISTICS</b>						
High Side Output Current Shutdown	I <sub>lim</sub>	20	35	50	A	
High Side Overcurrent Shutdown Delay	t <sub>lim</sub>		3	20	μs	From short to output shutdown
Low Side Overcurrent detection Vout to gnd	V <sub>out-fault</sub>	1	2	3	V	If the low side is ON (GLS>4.3V). This is a inferred overcurrent condition
Low Side Overcurrent detection Vout to gnd Shutdown Delay	t <sub>out-fault</sub>		3	10	μs	
Thermal Shutdown	T <sub>shut</sub>	150	175		°C	
Thermal Shutdown Hysteresis	T <sub>hyst</sub>		10		°C	
Under Voltage Shutdown Threshold	Vuv	6		8	V	
Under Voltage Shutdown hysteresis	Vuv-hyst		0.15		V	
Over Voltage Shutdown Threshold	Vov	27	29	31	V	
Over Voltage Shutdown hysteresis	Vov-hyst		0.15		V	
<b>CURRENT RECOPY CHARACTERISTICS</b>						
Current Recopy Ratio	Cr		3700			Iout from 4A to 8A Tj -40°C to 105°C
Current Recopy Ratio Accuracy Iout from 4A to 8A Iout from 8A to 20A	Cr-ac	-15 -10		15 10	%	Tj <125°C Garanteed by design
Current Recopy Clamp Voltage	Vclst	6 TBC	9	11 TBC	V	Current mirror=10mA No external resistor on Cur R pin.
<b>SWITCHING CHARACTERISTICS</b>						
High Speed Mode to Low Speed Mode transition pulse width	t <sub>smod</sub>	150	250	350	μs	
Gate Low Side Rise Time	T <sub>psrls</sub>		3.6		μs	From 10% to 90% Vout, Load=3Ω
Gate Low Side Fall Time	T <sub>nsrls</sub>		4.9		μs	From 90% to 10% Vout, Load=3Ω
<b>HIGH SPEED MODE SWITCHING CHARACTERISTICS (pulse&lt;280μs)</b>						

Freescale Semiconductor, Inc.

Description	Symbol	Characteristics			Unit	Conditions
		Min.	Typ.	Max.		
High Side Positive Slew Rate	Thr		10		V/ $\mu$ s	From 10% to 65% Vout, Load=3 $\Omega$
High Side Negative Slew Rate	Thf		40		V/ $\mu$ s	From 90% to 35% Vout, Load=3 $\Omega$
High Side Turn on Delay Time	thdon		2.5		$\mu$ s	To 10% Vout, Load=3 $\Omega$
High Side Turn off Delay Time	thdoff		1.5		$\mu$ s	To 90% Vout, Load=3 $\Omega$
<b>LOW SPEED MODE SWITCHING CHARACTERISTICS</b>						
High Side Maximum Output Positive Slew Rate	lr		1.0		V/ $\mu$ s	From 10% to 65% Vout, Load=3 $\Omega$
High Side Maximum Output Negative Slew Rate	T <sub>if</sub>		0.5		V/ $\mu$ s	From 90% to 35% Vout, Load=3 $\Omega$
High Side Turn on Delay Time	tldon		10		$\mu$ s	To 10% Vout, Load=3 $\Omega$
High Side Turn off Delay Time	tloff		80		$\mu$ s	To 90% Vout, Load=3 $\Omega$

**FUNCTIONAL TRUTH TABLE**

Standard HBridge Conditions	In1	In 2	Wake	Out1	Out2	GLS1	GLS2	St	Comment
<b>Normal Operation</b>	X	X	0	Z	Z	L	L	1	Standby Mode
	0	0	1	L	L	H	H	1	Brake to Ground
	1	0	1	H	L	L	H	1	Direction 1
	0	1	1	L	H	H	L	1	Direction 2
	1	1	1	H	H	L	L	1	Not Recommended Note 1
<b>Undervoltage</b>	X	X	1	Z	Z	L	L	1	Note 2
<b>Overvoltage</b>	X	X	1	L	L	H	H	1	Note 2
<b>Overtemp HS1</b>	H	L	1	L	L	L	L	0	Note 3
<b>Overtemp HS2</b>	L	H	1	L	L	L	L	0	Note 3
<b>Overcurrent HS1</b>	1	X	1	Z	X	L	X	0	Note 4
<b>Overcurrent HS2</b>	X	1	1	X	Z	X	L	0	Note 4
<b>Overcurrent LS1</b>	X	X	1	Z	Z	L	L	0	Note 5
<b>Overcurrent LS2</b>	X	X	1	Z	Z	L	L	0	Note 5

L = 'Low level' ; H = 'High level' ; X = 'don't care' ; Z = 'High Impedance'

**NOTES :**

1. It is not recommended to short the motor to Vbat. If in this mode an overvoltage condition occurred, this would damaged the DH5B.
2. Once the overvoltage condition or undervoltage condition is removed, the H-Bridge recovers its normal operation mode.
3. When the thermal shutdown is reached on one of the High Side MOSFET, both half bridges are turned off with the motor tied to ground. When the overtemperature condition is finished, the H-bridge recover it previous normal operation mode.
4. The High Side MOSFET HSx which experienced an overcurrent is latched off. The corresponding output OUTx is open. Once the High Side overcurrent condition is removed, the input INx has to be reset in order to recover the normal operation mode.
5. When a short to Vbat of one of the Low sides occurs, both outputs are opened to prevent the motor from running. Once the Low side overcurrent is removed, the input INx of the half bridge wich experienced the fault has to be reset in order to recover the normal operation mode.

**DEVICE DESCRIPTION**

**Introduction**

These devices are intended for full H-bridge automotive applications. The bridge is partitioned into three blocks, the DHSB and two low side MOSFETS, each block has a dedicated package.

The DHSB incorporates two 15m ohm N-channel high side power MOSFETS, high side current sensing, fault protection and low side gate drivers. The inputs are CMOS compatible, so they can directly interface with a microcontroller. The low side gate drivers control and protect the two external low sides. When the three blocks are combined the outputs (OUT1 and OUT2) are fully protected against shorts to GND, Shorts to Vbat, shorted loads, over/under voltage and over temperature.

**Power supply**

The device can be directly connected to the power supply line. The device has a standby mode (Wake at low logic level) with a ultra low consumption (10uA max). In operation when inputs are active, the supply current is up to 20mA.

With the high current and fast switching ability of the DHSB it is recommended that sufficient capacitance (tens of microfarads) be placed between Vbat and gnd of the IC. This will help to insure the power supply stays within the specified limits.

**Reverse battery protection.**

The device cannot sustain more than 1.5V of a reverse battery conditions because of the two body diodes of the power MOSFETS, which are forward biased during a reverse battery condition. A specific protection must be implemented.

**Figure 1. i Reverse Battery protection schematic**

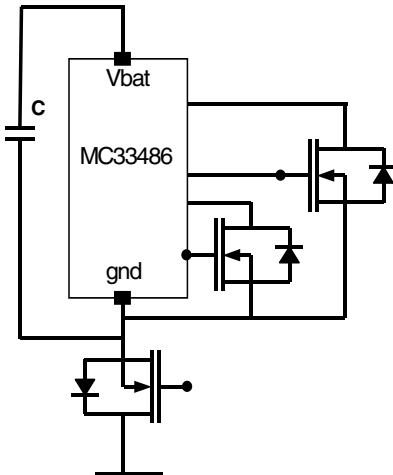

A reverse battery component might be needed in the gnd pin of the application (i.e diode or Mosfet) in order to achieve both reverse battery and negative transient pulses immunity.

If a polarized capacitor is used, it can be placed as shown in Figure 1. .

**Loss of ground protection**

As shown in the Figure 1. , a loss of ground has no bad impact on the DHSB, since the ground pin of the device is the same as the ground of the low side.

**Over/Under Voltage Protection**

If the battery voltage falls to a level below 8.0V, the outputs are turned low (Low Sides ON) in a low speed mode. The

DHSB goes back into normal operation mode as soon as the Vbat rise above the undervoltage threshold. The undervoltage protection circuitry has hysteresis.

The control circuitry also has an overvoltage detection which turns the Low sides ON and protects the load in case of Vbat exceeding 28V. The gate drivers will also be clamped to 14V to protect the external low side FETs. The Low sides remain in the ON state, until the over-voltage condition is removed.

Undervoltage and Overvoltage are not reported on the status output.

**Self-adjusted switching speed mode**

This feature allows for reduction in EMC and power dissipation depending on the application. The DHSB has two switching speeds (high and low) depending on the input pulse width. The high speed condition is active when the delay between two consecutive input edges is below 280us. The low speed mode is active when the delay between two consecutive input edges is above 280us. The 280us delay corresponds about to a 2kHz frequency with a duty cycle of 50%.

**Current Recopy**

This feature provides a current mirror with the ratio of 1/3700 of the high side output current. An external resistor must be connected to the Cur R pin and then tied to a microcontroller A/D input for analog voltage measurement. The Cur R pin is internally clamped (Vclst) to protect the MCU A/D input.

**Figure 2. Current Recopy Principle.**

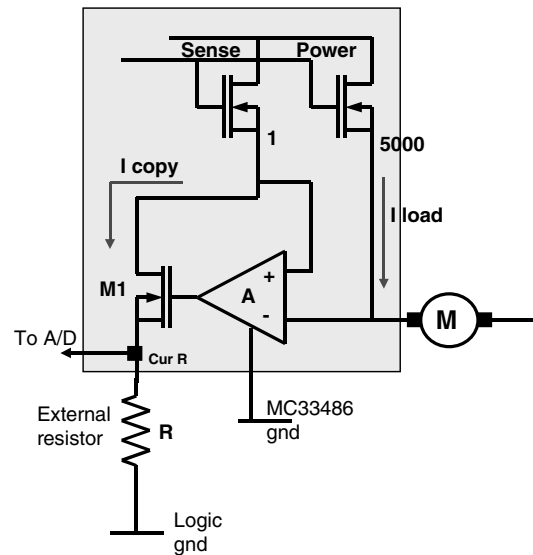

In case a ground shift occurs between the MCU and the DHSB, the amplifier A (see Figure 2. ), will adapt its output to keep the same I copy. Of course the shift has to keep between +/- 1V.

**Status**

The device has a single status pins which reports over temperature and/or over current faults. See the Functional Truth Table for all faults that are reported on this signal pin. This pin is an open drain structure and needs an external pull up resistor.

**DEVICE DESCRIPTION**

**Overtemperature Protection**

The DHSB incorporates over-temperature protection. Over-temperature detection occurs when an internal high side is in the on state. When an over-temperature condition occurs, both outputs are affected. Both outputs are turned off to protect the DHSB from damage (Low sides ON). The overtemperature protection circuitry incorporates hysteresis. Overtemperature fault condition is reported on the status output.

**High side overcurrent protection**

This device incorporates a current shutdown threshold of 35A typical. When this limit is reached due to an overload condition or a short to ground, the faulty output is tri-stated. To clear the fault the input (Inx) line needs to return low then on the next high transition the output will be enabled.

This information is reported on the status output.

**Low side block**

The low side block has control circuitry for two external N-Channel power MOSFET's. The low side control circuitry is PWM capable and protects the Low side MOSFETS in case of overcurrent (short to Vbat). This information is reported on the status output.

The low side Gate controls are clamped at 14V maximum to protect the gates of the Low Sides.

During normal operation, the outputs OUT1 and OUT2 are driven by the high side. The low side Gate driver's will only turn on when the Drain voltage (same connection as OUT1 or 2) of the internal high sides is less than 2V, which prevent any cross-conduction in the bridge.

**Low Side Overcurrent Protection**

Unlike the high side overcurrent circuitry, this overcurrent protection does not measure the current, but measures the effect of current on the low side through a condition:  $V_{gs} > 4.3V$  and  $V_{ds} > 2V$ . When this set of conditions occur for at least 8us (blanking time), both outputs OUT1 and OUT2 are tri-stated. The full bridge is tri-stated to prevent the motor for running in case of short to Vbat.

As  $V_{gs}$  and  $V_{ds}$  are measured in respect to the DHSB's ground pin, it is essential that the low side source are connected to this same ground, in order to prevent false overcurrent detection due to ground shifts.

**Package**

The high side block is assembled into a power surface mount package. This package offers high thermal performances, and high current capabilities. It offers 10 pins on each package sides, and one additional connection which is the package heat sink (called pin 21). The heat sink acts as the device power Vbat connection.

**Soldering Information**

This device is packaged in a Surface Mount Power package intended to be soldered directly on the Printed Circuit Board.

This device was qualified according to JEDEC standards JESD22-A113-B and J-STD-020A with the reflow conditions applicable for packages with thickness above 2.5mm:

- Convection 220°C +5/-0°C
- VPR 215-219°C
- IR / Convection 220°C +5/-0°C

The maximum peak temperature during the soldering process should not exceed 220°C (+5°C/-0°C). The time at maximum temperature should range from 10 to 40s max.

**Thermal Management**

The junction to case thermal resistance is 2°C/W maximum. The junction to ambient thermal resistance is dependant on the mounting technology, and if an additional heat sink is used. One of the most commonly used mounting technique consists of using the printed circuit board and the copper lines as heat sink.

Figure 2 is an example of printed circuit board layout. It has a total of 10cm<sup>2</sup> additional copper on two sides (2.5 cm<sup>2</sup> on the top side and 7.5 cm<sup>2</sup> on the down side).

**Figure 3. .Printed Board Layout Example (not to scale)**

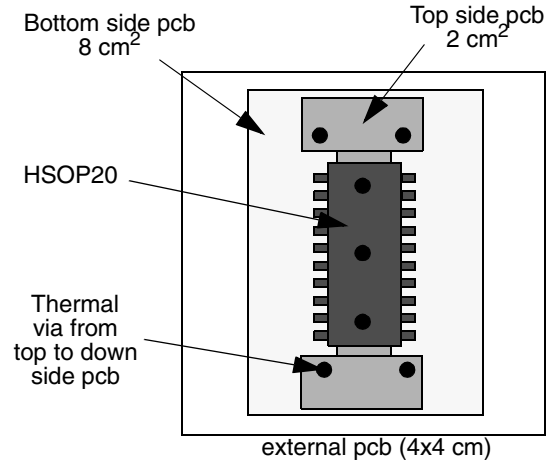

With the above layout, thermal resistance junction to ambient of 25°C/W can be achieved. This value being splitted into:

- . junction to case :  $R_{thjc} = 2^\circ C/W$
- . case to ambient :  $R_{thca} = 23^\circ C/W$ .

Lower value can be reached with the help of larger and thicker copper metal, higher number of thermal via from top to bottom side pcb and the use of additional thermal via from the circuit board to the module case.

**Thermal model**

The junction to ambient thermal resistance of the circuit mounted on a printed circuit board can be splitted into two main parts: junction to case and case to ambient resistances.

A simplified steady state model is shown in figure 3 below.

**Figure 4. Simplified Thermal Model (Electrical Equivalent)**

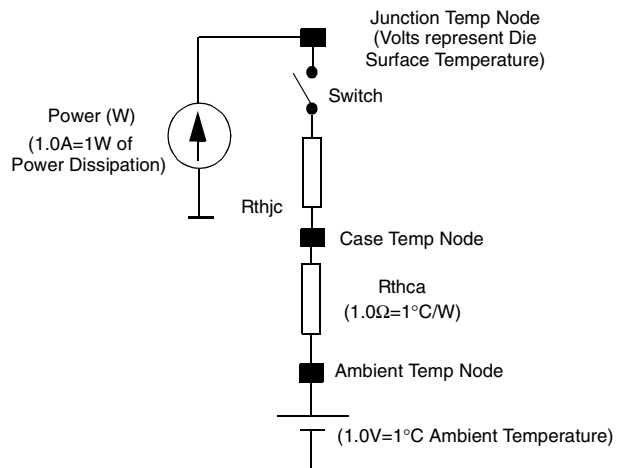

**For More Information On This Product,**

**Go to [www.freescale.com](http://www.freescale.com)**

The use of this model is similar to the electrical Ohm law (voltage = resistance X current), where:

- . Voltage represents temperature
- . Current represents power dissipated by the device
- . Resistance represents thermal resistance.

We finally got :

Temperature or delta temperature = Power Dissipation times Thermal resistance, that is :  $^{\circ}\text{C} = \text{W} \times \text{C}/\text{W}$ .

Any node temperature can easily be calculated knowing the amount of power flowing through the thermal resistances.

Example :

1. Numerical value.

. Junction to case thermal resistance :  $2^{\circ}\text{C}/\text{W}$  (Rthjc)

. Power into the switch : assuming the device is driving 8amps at  $150^{\circ}\text{C}$  junction temperature (Rdson at  $150^{\circ}\text{C}$  is  $40\text{m}\Omega$ ) the total power dissipation is :  $0.04 \times 8 \times 8 = 2.56\text{W}$

. Case to ambient thermal resistance (Rthca) :  $20^{\circ}\text{C}/\text{W}$

2. Results.

. Junction to case delta temp :  $5^{\circ}\text{C}$  ( $2.5\text{W} \times 2^{\circ}\text{C}/\text{W}$ )

. Case delta temp from ambient :  $50^{\circ}\text{C}$  ( $20^{\circ}\text{C}/\text{W} \times 2.5\text{W}$ )

. Actual junction temperature node will be :

$50^{\circ}\text{C} + 5^{\circ}\text{C} = 55^{\circ}\text{C}$  above the ambient temperature.

Assuming an  $85^{\circ}\text{C}$  ambient temperature, the junction temperature is a t :  $85 + 55 = 140^{\circ}\text{C}$ .

The above example take into account the junction to ambient thermal resistance, assuming that the ambient temp is  $85^{\circ}\text{C}$ .

In the case where the device plus its printed circuit board are located inside a module, the ambient temp of the module should be taken into account. Or an additional thermal resistance from inside module to external ambient temperature must be added. The calculation method remains the same.

The low side block is packaged into D<sup>2</sup>PAK or DPAK package. Thermal resistance junction to case is approx.  $2^{\circ}\text{C}/\text{W}$ . The junction to ambient thermal resistance follows the same rules as for the high side block, and is in the same range.

Motorola reserves the right to make changes without further notice to any products herein. Motorola makes no warranty, representation or guarantee regarding the suitability of its products for any particular purpose, nor does Motorola assume any liability arising out of the application or use of any product or circuit, and specifically disclaims any and all liability, including without limitation consequential or incidental damages. "Typical" parameters which may be provided in Motorola data sheets and/or specifications can and do vary in different applications and actual performance may vary over time. All operating parameters, including "Typical" must be validated for each customer application by customer's technical experts. Motorola does not convey any license under its patent rights nor the rights of others. Motorola products are not designed, intended, or authorized for use as components in systems intended for surgical implant into the body, or other applications intended to support or sustain life, or for any application in which the failure of the Motorola product could create a situation where personal injury or death may occur. Should Buyer purchase or use Motorola products for any such unintended or unauthorized application, Buyer shall indemnify and hold Motorola and its officers, employees, subsidiaries, affiliates, and distributors harmless against all claims, costs, damages, and expenses, and reasonable attorney fees arising out of, directly or indirectly, any claim of personal injury or death associated with such unintended or un authorized use, even if such claim alleges that Motorola was negligent regarding the design or manufacture of the parts. Motorola and  are registered trademarks of Motorola, Inc. Motorola, Inc. is an Equal Employment Opportunity/Affirmative Action Employer.

**How to reach us:**

**USA / EUROPE / Locations Not Listed:** Motorola Literature Distribution;  
P.O. Box 5405, Denver, Colorado 80217. 1-303-675-2140 or 1-800-441-2447

**JAPAN:** Motorola Japan Ltd.; SPS, Technical Information Center, 3-20-1,  
Minami-Azabu, Minato-ku, Tokyo 106-8573 Japan. 81-3-344-3569

**Technical Information Center: 1-800-521-6274**

**ASIA / PACIFIC:** Motorola Semiconductors H.K. Ltd.; Silicon Harbour Centre,  
2, Dai King Street, Tai Po Industrial Estate, Tai Po, N.T., Hong Kong.  
852-26668334

**HOME PAGE:** <http://www.motorola.com/semiconductors>



**MOTOROLA**

**For More Information On This Product,  
Go to: [www.freescale.com](http://www.freescale.com)**

MC33486/D

## Looking for pricing, stock, or lifecycle information?

Click below to explore more details on WIN SOURCE:

 [View MC33486DH on WIN SOURCE](#)

 [NXP / Nexperia Information](#)

## Optimize Your Supply Chain with WIN SOURCE Solutions

-  Global Sourcing Solution
-  Obsolete Management
-  Cost Control Management
-  Shortage Management
-  Alternative Solution
-  Excess Inventory Management