

DIFFERENTIAL VARIABLE GAIN AMPLIFIER

- LOW NOISE : 4.6nV/√Hz
- LOW DISTORTION
- HIGH SLEW RATE : 90V/μs
- WIDE BANDWIDTH : 52MHz @ -3dB & 18dB gain
- GAIN PROGRAMMABLE from -9dB to +30dB with 3dB STEPS
- POWER DOWN FUNCTION

DESCRIPTION

The TS652 is a differential digitally controled variable gain amplifier featuring a high slew rate of 90V/μs, a large bandwidth, a very low distortion and a very low current and voltage noise.

The gain can be set from -9dB to +30dB through a 4bit digital word, with 3dB steps.

The gain monotonicity is guaranteed by design.

This device is particularly intended for applications such as preamplification in telecommunication systems using multiple carriers.

APPLICATION

- Preamplifier and automatic gain control for Assymetric Digital Subscriber Line (ADSL).

ORDER CODE

Part Number	Temperature Range	Package
		D
TS652ID	-40, +85°C	•

D = Small Outline Package (SO) - also available in Tape & Reel (DT)

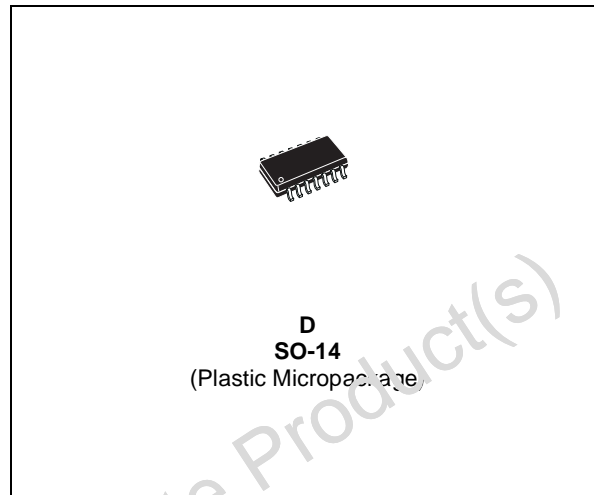

PIN CONNECTIONS (top view)

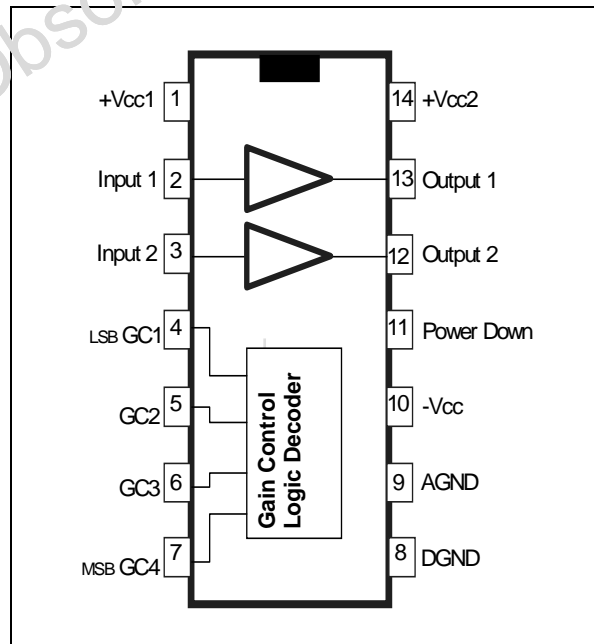

ABSOLUTE MAXIMUM RATINGS

Symbol	Parameter	Value	Unit
V_{CC}	Supply voltage ¹⁾	14	V
V_i	Input Voltage ²⁾	0 to 14	V
T_{oper}	Operating Free Air Temperature Range TS652ID	-40 to + 85	°C
T_{std}	Storage Temperature	-65 to +150	°C
T_j	Maximum Junction Temperature	150	°C
R_{thjc}	Thermal Resistance Junction to Case	22	°C/W
R_{thja}	Thermal Resistance Junction to Ambiente Area	125	°C/W
	Output Short Circuit Duration	Infinite	

1. All voltages values are with respect to network terminal.
2. The magnitude of input and output voltages must never exceed $V_{CC} + 0.3V$.

OPERATING CONDITIONS

Symbol	Parameter	Value	Unit
V_{CC}	Supply Voltage	5 to 12	V
V_{icm}	Common Mode Input Voltage	$V_{CC}/2$	V

Obsolete Product(s) - Obsolete Product(s)

ELECTRICAL CHARACTERISTICS. $V_{CC} = \pm 6\text{Volts}$, $T_{amb} = 25^\circ\text{C}$ (unless otherwise specified).

Symbol	Parameter	Test Condition	Min.	Typ.	Max	Unit
DC PERFORMANCE						
V_i	Voltage on the Input Pin			0		V
I_{CC}	Total Supply Current	No load, $V_{out} = 0$		28		mA
ΔV_{OFFSET}	Differential Input Offset Voltage	$V_{in} = 0$, $A_V = 30\text{dB}$			6	mV
SVR	Supply Voltage Rejection Ratio	$A_V = 0\text{dB}$	50	80		dB
POWER DOWN MODE						
V_{pdw}	Thershold Voltage for Power Down Mode (high level active)	Low Level		0	0.8	V
		High Level	2	3.3		V
I_{ccpdw}	Power Down Total Consumption	Power Down Mode			150	μA
Z_{out}	Power Down Output Impedance	Power Down Mode	100k Ω	150k Ω /5pF		
AC PERFORMANCE						
Z_{in}	Input Impedance			100k Ω /5pF		
V_{OH}	High Level Output Voltage R_L connected to GND	$R_L = 500\Omega$	4	4.5		V
V_{OL}	Low Level Output Voltage R_L connected to GND	$R_L = 500\Omega$		-4.5	-4	V
A_V	Voltage Gain	$F = 1\text{MHz}$	-9		30	dB
	Gain monotonicity guaranteed by design					
P_{AV}	Precision of the Voltage Gain	$F = 1\text{MHz}$	-1		1	dB
A_{vstep}	Step Value	$F = 1\text{MHz}$	2.4	3	3.6	dB
A_{vmin}	Gain Mismatch between Both Channels	$F = 1\text{MHz}$			1	dB
B_w	Bandwidth @ -3dB $R_L = 500\Omega$ $C_L = 15\text{pF}$	$A_V = -9\text{dB}$	55	110	200	MHz
		$A_V = 0\text{dB}$	32	69	132	
		$A_V = +18\text{dB}$	26	52	100	
		$A_V = +30\text{dB}$	10	18	36	
R_{bw}	Bandwidth Roll-off	$A_V = +30\text{dB}$, $F = 1\text{MHz}$		0.08		dB
I_o	Bandwidth @ -3dB $R_L = 500\Omega$, $C_L = 15\text{pF}$	Source	17	28		mA
		Sink	17	22		
SR	Slew Rate (gain independent)	$V_o = 2\text{Vpeak}$	50	100		V/ μs
NOISE AND DISTORTION						
i_n	Equivalent Input Noise Current	$F = 100\text{kHz}$		1.5		pA/ $\sqrt{\text{Hz}}$
e_n	Equivalent Input Noise Voltage	$F = 100\text{kHz}$ $A_V = 30\text{dB}$		4.6		nV/ $\sqrt{\text{Hz}}$
THD30	Harmonic Distorsion	1Vpeak, $F = 150\text{kHz}$, $A_V = +30\text{dB}$, $R_L = 500\Omega$ /15pF				dBc
		H2		-70		
		H3		-93		
		H4		-98		
		H5		-99		
IM3	Third Order Intermodulation Product $F_1 = 180\text{kHz}$, $F_2 = 280\text{kHz}$	$V_{out} = 1\text{Vpeak}$, $A_V = +30\text{dB}$ $R_L = 500\Omega$ /15pF				dBc
		@ 80kHz		-77		
		@ 380kHz		-85		
		@ 640kHz		-86		
		@ 740kHz		-87		
IM3	Third Order Intermodulation Product $F_1 = 70\text{kHz}$, $F_2 = 80\text{kHz}$	$V_{out} = 1\text{Vpeak}$, $A_V = +30\text{dB}$ $R_L = 500\Omega$ /15pF				dBc
		@ 60kHz		-77		
		@ 90kHz		-79		
		@ 220kHz		-83		
		@ 230kHz		-84		

DIGITAL INPUTS

Symbol	Parameter	Min.	Typ.	Max.	Unit
GC1, GC2, GC3 and GC4	Low Level		0	0.8	V
	High Level	2	3.3		

SIMPLIFIED SCHEMATIC

The TS652 consists of two independent channels.

Each channel has two stages. The first is a very low noise digitally controlled variable gain amplifier (range 0 to 18dB).

The TS652 features a high input impedance and a low noise current. To minimize the overall noise figure, the source impedance must be less than 3kΩ.

This value gives an equal contribution of voltage and current noises.

The second stage is a gain/attenuation stage (+12dB to -9dB) featuring a low output impedance.

This output stage can drive loads as low as 500Ω.

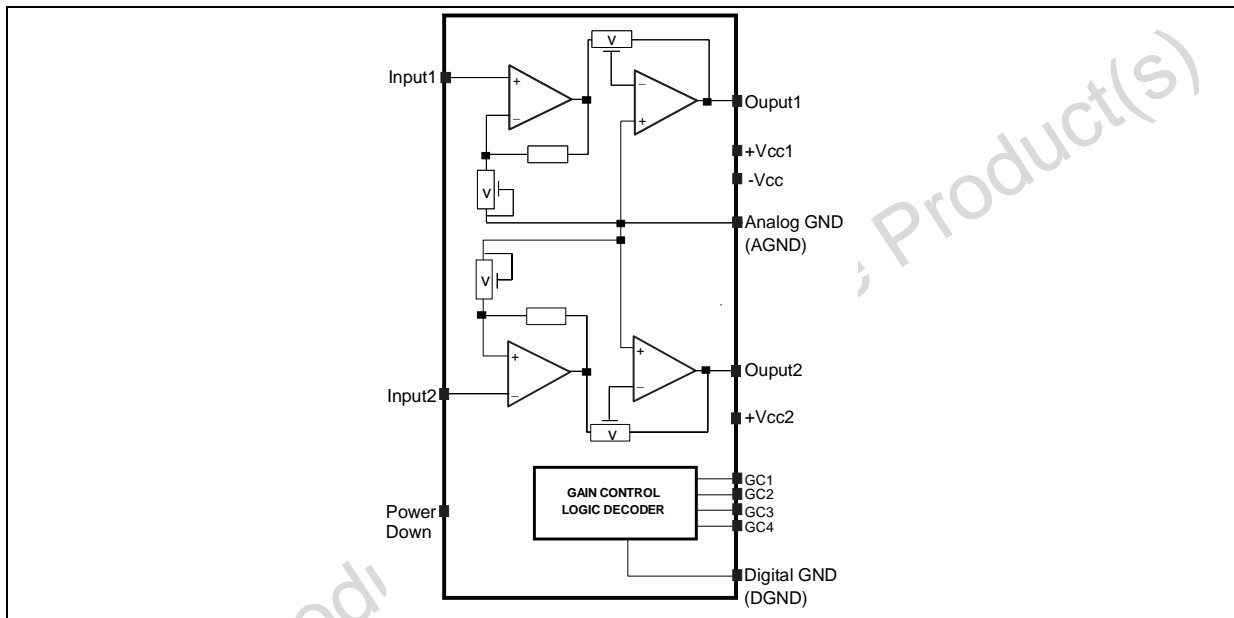

POWER DOWN MODE POSITION

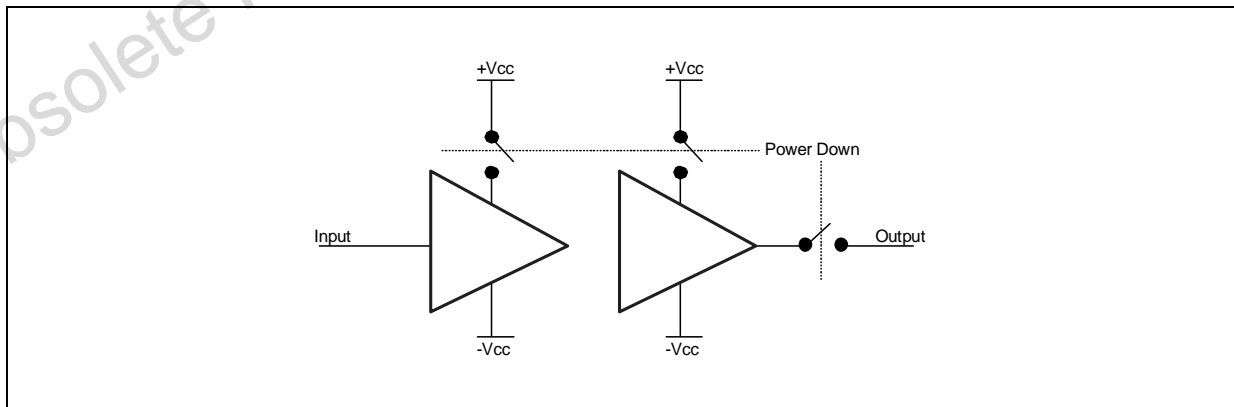

BANDWIDTH

The small signal bandwidth is almost constant for gains between +18dB to 0dB and is in the order of 52MHz to 70MHz respectively. For 30dB gain the bandwidth is around 18MHz.

The power bandwidth is typically equal to 30MHz for 2V peak to peak signals.

MAXIMUM INPUT LEVEL

The input level must not exceed the following values :

negative peak value: must be greater than $-V_{CC} + 1.5V$

positive peak value: must be less than $+V_{CC} - 1.5V$

For example, if a $\pm 6V$ power supply is used, the input signal can swing between -4.5V and +4.5V.

These values are due to common mode input range limitations of the input stage of the first amplifier.

Some other limitations may occur, due to the slew rate of the first operational amplifier (typically in the order of 300V/ μs). This means that the maximum input signal decreases at high frequency.

SINGLE SUPPLY OPERATION

The incoming signal is AC coupled to the inputs.

The TS652 can be used either with a dual or a single supply. If a single supply is used, the inputs are biased to the mid supply voltage ($+V_{CC2}$). This bias network must be carefully designed, in order to reject any noise present on the supply rail.

The AGND pin (9) must be connected to $+V_{CC2}$. The bias current of the second stage (inverting structure) is 8 μA for both amplifiers. A resistor divider structure can be used. Two resistances should be chosen by considering 8 μA as the 1% of the total current through these resistances. For a single +12V supply voltage, two resistances of 7.5k Ω can be used. The differential input consists of a high pass circuit, formed by the 1 μF capacitor and a 1k Ω resistance and gives a break frequency of 160Hz.

SINGLE +12V SUPPLY OF THE TS652

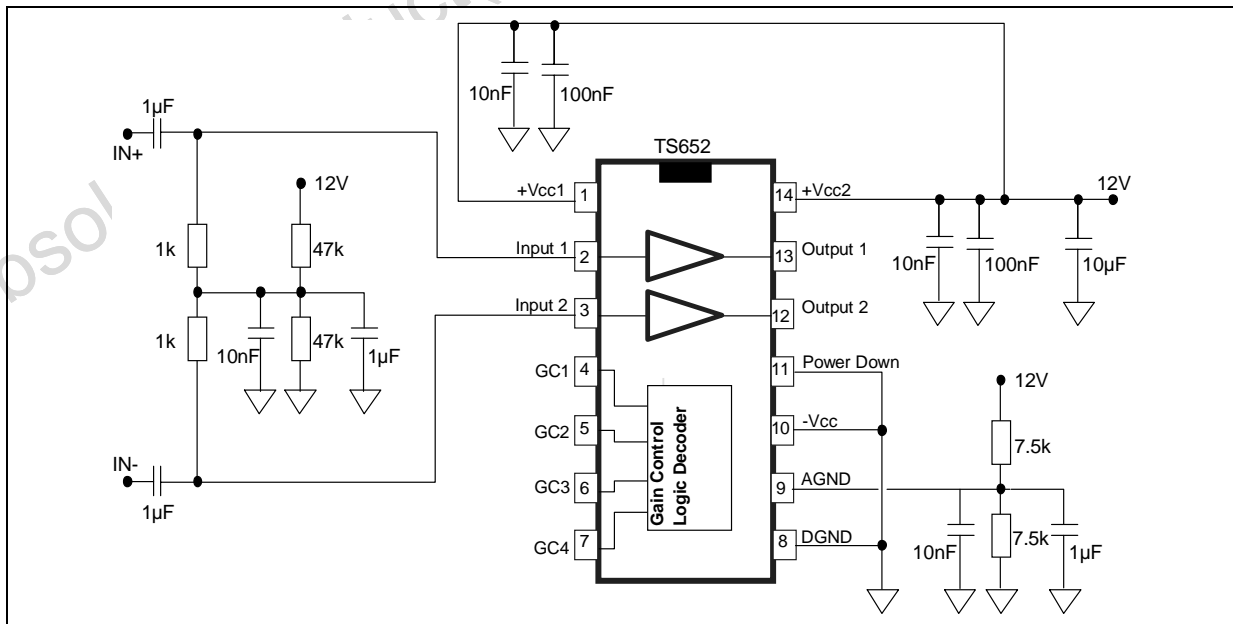

GAIN CONTROL

The gain and the power down mode is programmed with a 4 bit digital word :

Digital Control GC4....GC1 MSB LSB	Total Gain (dB)	First Stage Gain (dB)	Second Stage Gain (dB)	Maximum Input Level	Bandwidth Small Signal	Eq. Input Noise (nV/√Hz)
\$0000	-9	0	-9	2.8Vrms	110mHZ	29
\$0001	-6	0	-6	2.8Vrms	100MHz	26
\$0010	-3	0	-3	2.8Vrms	85MHz	23
\$0011	0	0	0	2.8Vrms	69MHz	22
\$0100	3	3	0	2Vrms	63MHz	16
\$0101	6	6	0	1.4Vrms	58MHz	12
\$0110	9	9	0	1Vrms	56MHz	9
\$0111	12	12	0	0.7Vrms	55MHz	7
\$1000	15	15	0	0.5Vrms	54MHz	6
\$1001	18	18	0	0.35Vrms	52MHz	4.8
\$1010	21	21	3	0.25Vrms	42MHz	4.7
\$1011	24	24	6	175mVrms	30MHz	4.7
\$1100	27	27	9	125mVrms	24MHz	4.6
\$1101	30	30	12	88mVrms	18MHz	4.6
\$1110	30	30	12	88mVrms	18MHz	4.6
\$1111	30	30	12	88mVrms	18MHz	4.6

The gain is the same for both channels.
The digital inputs are CMOS compatible. The supply voltage of the logic decoder used to transcode the digital word can be either 3.3V or 5V or V_{CC}.

Closed Loop Gain vs Frequency

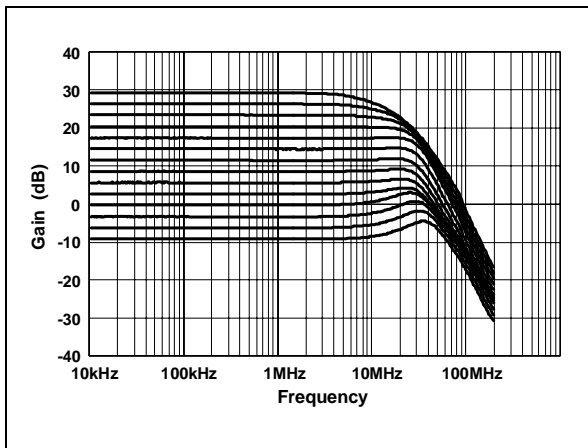

Bandwidth vs Gain

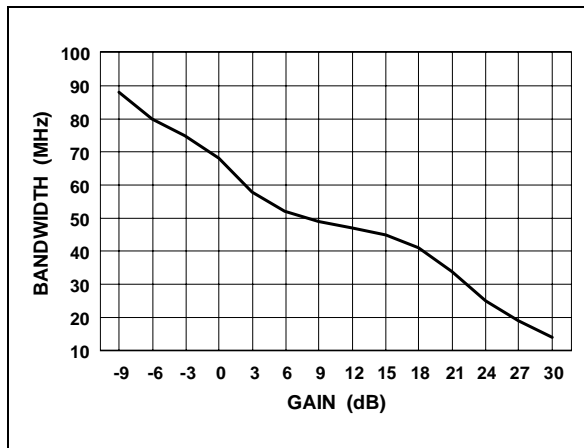

Negative & Positive Slew Rate vs Gain

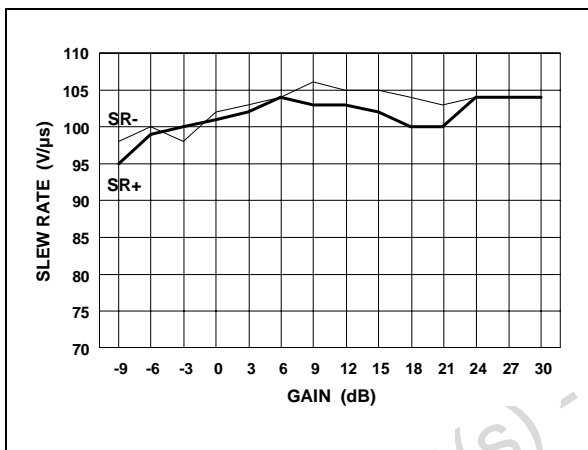

Equivalent Input Voltage Noise vs Gain

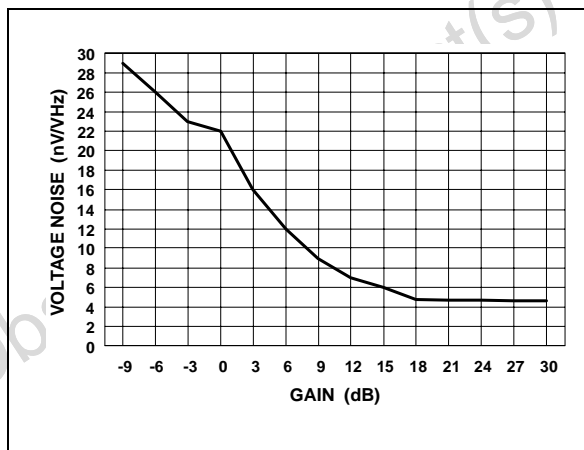

Gain Switching (+15dB to -9dB)

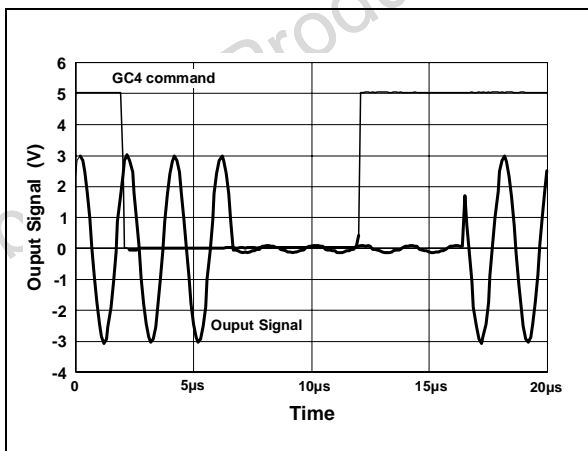

Gain Switching (+30dB to +9dB)

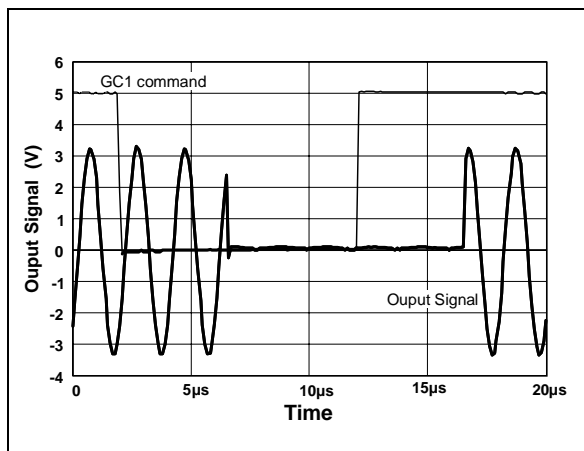

measurement conditions: $V_{cc}=\pm 6V$, $R_{load}=500\Omega$, $T_{amb}=25^{\circ}C$



Output/Input Isolation in Power Down Mode vs Frequency

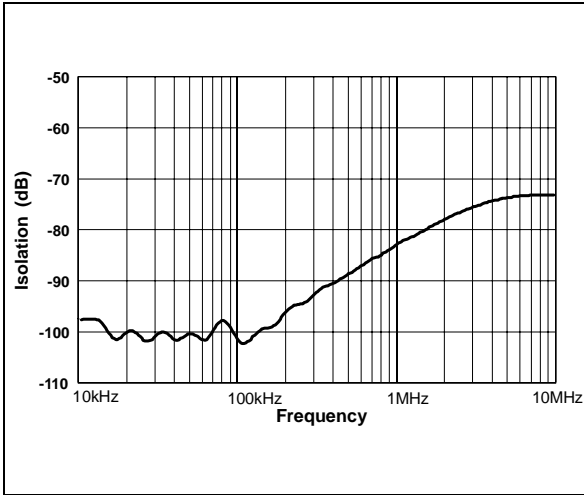

3rd Order Intermodulation (2 tones : 180kHz and 280kHz)

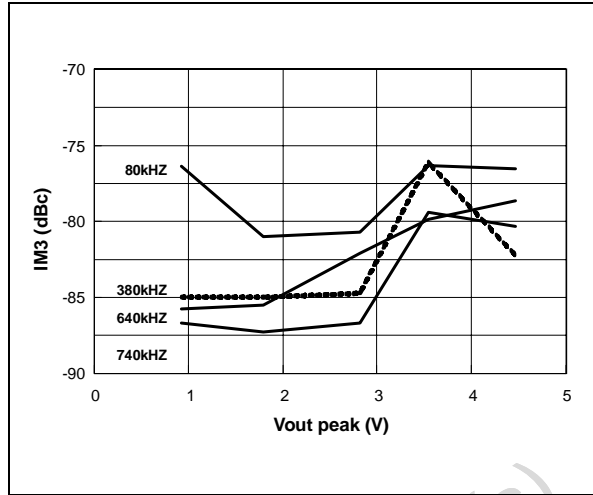

3rd Order Intermodulation (2 tones : 180kHz and 280kHz)

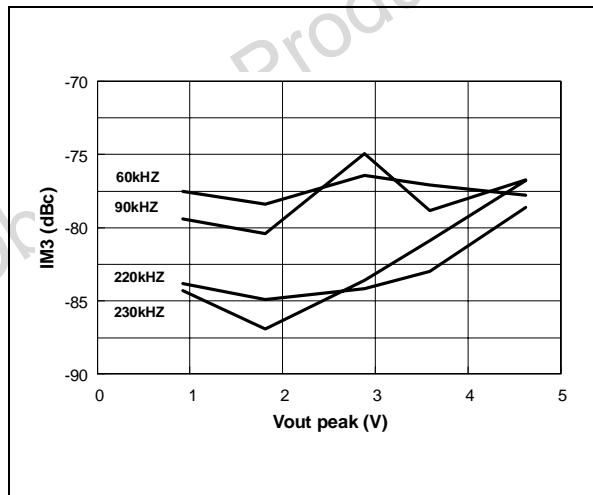

measurement conditions: Vcc=±6V, Rload=500Ω, Tamb=25°C

PACKAGE MECHANICAL DATA
 14 PINS - PLASTIC MICROPACKAGE (SO)

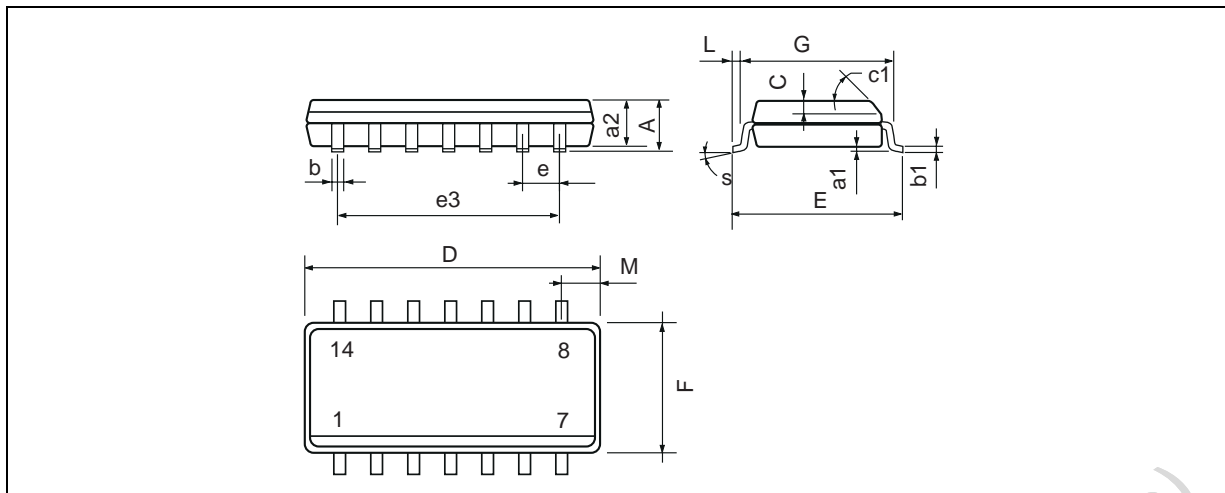

Dimensions	Millimeters			Inches		
	Min.	Typ.	Max.	Min.	Typ.	Max.
A			1.75			0.069
a1	0.1		0.2	0.004		0.008
a2			1.6			0.063
b	0.35		0.46	0.014		0.018
b1	0.19		0.25	0.007		0.010
C		0.5			0.020	
c1	45° (typ.)					
D (1)	8.55		8.75	0.336		0.344
E	5.8		6.2	0.228		0.244
e		1.27			0.050	
e3		7.62			0.300	
F (1)	3.8		4.0	0.150		0.157
G	4.6		5.3	0.181		0.208
L	0.5		1.27	0.020		0.050
M			0.68			0.027
S	8° (max.)					

Note : (1) D and F do not include mold flash or protrusions - Mold flash or protrusions shall not exceed 0.15mm (.066 inc) ONLY FOR DATA BOOK.

Information furnished is believed to be accurate and reliable. However, STMicroelectronics assumes no responsibility for the consequences of use of such information nor for any infringement of patents or other rights of third parties which may result from its use. No license is granted by implication or otherwise under any patent or patent rights of STMicroelectronics. Specifications mentioned in this publication are subject to change without notice. This publication supersedes and replaces all information previously supplied. STMicroelectronics products are not authorized for use as critical components in life support devices or systems without express written approval of STMicroelectronics.

© The ST logo is a registered trademark of STMicroelectronics

© 2001 STMicroelectronics - Printed in Italy - All Rights Reserved
 STMicroelectronics GROUP OF COMPANIES



Australia - Brazil - China - Finland - France - Germany - Hong Kong - India - Italy - Japan - Malaysia - Malta - Morocco
 Singapore - Spain - Sweden - Switzerland - United Kingdom

© <http://www.st.com>



Looking for pricing, stock, or lifecycle information?

Click below to explore more details on WIN SOURCE:

-  [View TS652ID on WIN SOURCE](#)
-  [STMicroelectronics Information](#)

Optimize Your Supply Chain with WIN SOURCE Solutions

-  Global Sourcing Solution
-  Obsolete Management
-  Cost Control Management
-  Shortage Management
-  Alternative Solution
-  Excess Inventory Management