



# NLSX0102

## 2-Bit 20 Mb/s Dual-Supply Level Translator

The NLSX0102 is a 2-bit configurable dual-supply bidirectional auto sensing translator that does not require a directional control pin. The I/O  $V_{CC}$  and I/O  $V_L$  ports are designed to track two different power supply rails,  $V_{CC}$  and  $V_L$  respectively. Both the  $V_{CC}$  and  $V_L$  supply rails are configurable from 1.5 V to 5.5 V. This allows voltage logic signals on the  $V_L$  side to be translated into lower, higher or equal value voltage logic signals on the  $V_{CC}$  side, and vice-versa.

The NLSX0102 translator has integrated 10 k $\Omega$  pull-up resistors on the I/O lines. The integrated pull-up resistors are used to pull-up the I/O lines to either  $V_L$  or  $V_{CC}$ . The NLSX0102 is an excellent match for open-drain applications such as the I<sup>2</sup>C communication bus.

### Features

- $V_L$  can be Less than, Greater than or Equal to  $V_{CC}$
- Wide  $V_{CC}$  Operating Range: 1.5 V to 5.5 V  
Wide  $V_L$  Operating Range: 1.5 V to 5.5 V
- High-Speed with 24 Mb/s Guaranteed Data Rate
- Low Bit-to-Bit Skew
- Enable Input and I/O Pins are Overvoltage Tolerant (OVT) to 5.5 V
- Non-preferential Power-up Sequencing
- Integrated 10 k $\Omega$  Pull-up Resistors
- Small Space Saving Package  
– 1.9 mm x 0.9 mm x 0.5 mm Flipchip8
- This is a Pb-Free Device

### Typical Applications

- I<sup>2</sup>C, SMBus
- Low Voltage ASIC Level Translation
- Mobile Phones, PDAs, Cameras

### Important Information

- ESD Protection for All Pins  
– Human Body Model (HBM) > 7000 V



ON Semiconductor®

[www.onsemi.com](http://www.onsemi.com)

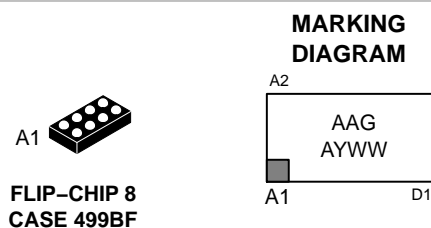

### PIN ASSIGNMENTS

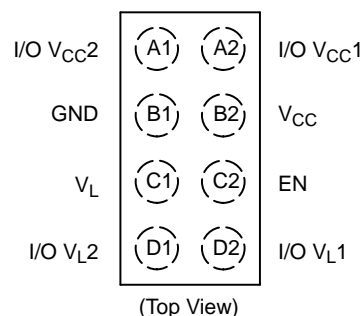

### LOGIC DIAGRAM

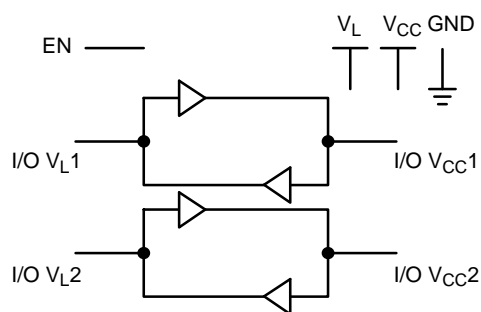

### ORDERING INFORMATION

See detailed ordering and shipping information in the package dimensions section on page 9 of this data sheet.

# NLSX0102

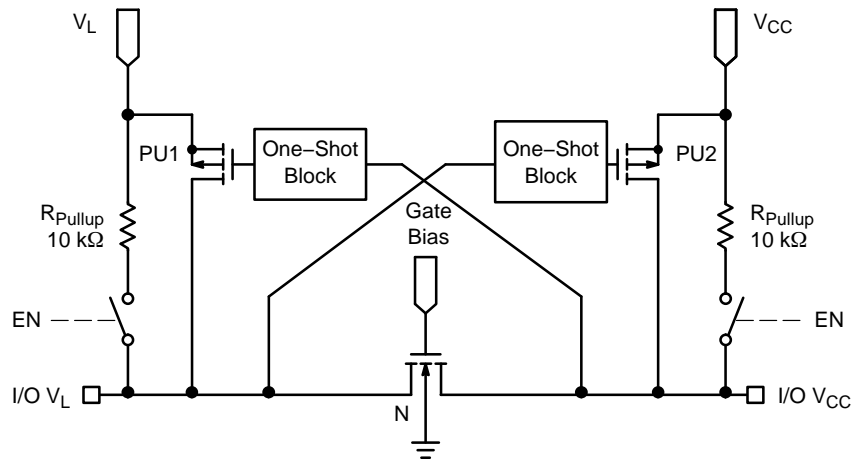

Figure 1. Block Diagram (1 I/O Line)

## PIN ASSIGNMENT

Pins	Description
V <sub>CC</sub>	V <sub>CC</sub> Supply Voltage
V <sub>L</sub>	V <sub>L</sub> Supply Voltage
GND	Ground
EN	Output Enable, referenced to V <sub>L</sub>
I/O V <sub>CCn</sub>	I/O Port, referenced to V <sub>CC</sub>
I/O V <sub>Ln</sub>	I/O Port, referenced to V <sub>L</sub>

## FUNCTION TABLE

EN	Operating Mode
L	Hi-Z
H	I/O Buses Connected

## MAXIMUM RATINGS

Symbol	Parameter	Value	Condition	Unit
V <sub>CC</sub>	High-side DC Supply Voltage	-0.5 to +7.0		V
V <sub>L</sub>	Low-side DC Supply Voltage	-0.5 to +7.0		V
I/O V <sub>CC</sub>	V <sub>CC</sub> -referenced DC Input / Output Voltage	-0.5 to +7.0		V
I/O V <sub>L</sub>	V <sub>L</sub> -referenced DC Input / Output Voltage	-0.5 to +7.0		V
V <sub>EN</sub>	Enable Control Pin DC Input Voltage	-0.5 to +7.0		V
I <sub>I/O_SC</sub>	Short-Circuit Duration (I/O V <sub>L</sub> and I/O V <sub>CC</sub> to GND)	±50	Continuous	mA
I <sub>I/O_K</sub>	Input / Output Clamping Current (I/O V <sub>L</sub> and I/O V <sub>CC</sub> )	-50	V <sub>I/O</sub> < 0	mA
T <sub>STG</sub>	Storage Temperature	-65 to +150		°C

Stresses exceeding those listed in the Maximum Ratings table may damage the device. If any of these limits are exceeded, device functionality should not be assumed, damage may occur and reliability may be affected.

# NLSX0102

## RECOMMENDED OPERATING CONDITIONS

Symbol	Parameter	Min	Max	Unit
$V_{CC}$	High-side Positive DC Supply Voltage	1.5	5.5	V
$V_L$	Low-side Positive DC Supply Voltage	1.5	5.5	V
$V_{EN}$	Enable Control Pin Voltage	GND	5.5	V
$V_{IO}$	I/O Pin Voltage	GND	5.5	V
$\Delta t/\Delta V$	Input Transition Rise and Fall Rate I/O $V_L$ and I/O $V_{CC}$ Ports, Push-Pull Driving		10	ns/V
	Control Input		10	
$T_A$	Operating Temperature Range	-40	+85	°C

## DC ELECTRICAL CHARACTERISTICS ( $T_A = -40$ to $+85$ °C, unless otherwise specified)

Symbol	Parameter	Test Conditions (Note 1)	$V_L$	$V_{CC}$	-40 °C to +85 °C			Unit
					Min	Typ (Notes 1, 2)	Max	
$V_{IHC}$	I/O $V_{CC}$ Input HIGH Voltage		1.5 to 5.5	1.5 to 5.5	$V_{CC} - 0.4$		-	V
$V_{ILC}$	I/O $V_{CC}$ Input LOW Voltage		1.5 to 5.5	1.5 to 5.5			0.15	V
$V_{IHL}$	I/O $V_L$ Input HIGH Voltage		1.5 to 5.5	1.5 to 5.5	$V_L - 0.4$		-	V
$V_{ILL}$	I/O $V_L$ Input LOW Voltage		1.5 to 5.5	1.5 to 5.5			0.15	V
$V_{IH}$	Control Pin Input HIGH Voltage		1.5 to 5.5	1.5 to 5.5	$0.65 * V_L$		-	V
$V_{IL}$	Control Pin Input LOW Voltage		1.5 to 5.5	1.5 to 5.5			$0.35 * V_L$	V
$V_{OHC}$	I/O $V_{CC}$ Output HIGH Voltage	I/O $V_{CC}$ source current = $-20 \mu A$	1.5 to 5.5	1.5 to 5.5	$2/3 * V_{CC}$		-	V
$V_{OLC}$	I/O $V_{CC}$ Output LOW Voltage	I/O $V_{CC}$ sink current = 1 mA	1.5 to 5.5	1.5 to 5.5			0.4	V
$V_{OHL}$	I/O $V_L$ Output HIGH Voltage	I/O $V_L$ source current = $-20 \mu A$	1.5 to 5.5	1.5 to 5.5	$2/3 * V_L$		-	V
$V_{OLL}$	I/O $V_L$ Output LOW Voltage	I/O $V_L$ sink current = 1 mA	1.5 to 5.5	1.5 to 5.5			0.4	V
$I_{QVL}$	$V_L$ Supply Current Supply Current	I/O $V_{CC}$ and I/O $V_L$ unconnected, $V_{EN} = V_L$	1.5 to 5.5	1.5 to 5.5			2.0	$\mu A$
			5.5	0			2.0	
			0	5.5			-1.0	
$I_{QVCC}$	$V_L$ Supply Current Supply Current	I/O $V_{CC}$ and I/O $V_L$ unconnected, $V_{EN} = V_L$	1.5 to 5.5	1.5 to 5.5			2.0	$\mu A$
			5.5	0			2.0	
			0	5.5			-1.0	
$I_{TS-VCC}$	$V_{CC}$ Tri-state Output Mode	I/O $V_{CC}$ and I/O $V_L$ unconnected, $V_{EN} = GND$	1.5 to 5.5	1.5 to 5.5			1.0	$\mu A$
$I_{TS-VL}$	$V_L$ Tri-state Output Mode Supply Current	I/O $V_{CC}$ and I/O $V_L$ unconnected, $V_{EN} = GND$	1.5 to 5.5	1.5 to 5.5			1.0	$\mu A$

1. Typical values are for  $V_{CC} = +3.3$  V,  $V_L = +1.8$  V and  $T_A = +25$  °C.

2. All units are production tested at  $T_A = +25$  °C. Limits over the operating temperature range are guaranteed by design.

# NLSX0102

## DC ELECTRICAL CHARACTERISTICS ( $T_A = -40$ to $+85$ °C, unless otherwise specified)

Symbol	Parameter	Test Conditions (Note 1)	$V_L$	$V_{CC}$	-40 °C to +85 °C			Unit
					Min	Typ (Notes 1, 2)	Max	
$I_I$	Enable Pin Input Leakage Current		1.5 to 5.5	1.5 to 5.5			1.0	$\mu A$
$I_{OZ}$	I/O Tri-state Output Mode Leakage Current		1.5 to 5.5	1.5 to 5.5			1.0	$\mu A$
$R_{PU}$	Pull-Up Resistors I/O $V_L$ and $V_C$					10		k $\Omega$

1. Typical values are for  $V_{CC} = +3.3$  V,  $V_L = +1.8$  V and  $T_A = +25$  °C.
2. All units are production tested at  $T_A = +25$  °C. Limits over the operating temperature range are guaranteed by design.

## Timing Characteristics – Rail-to-Rail Driving Configuration

(I/O test circuits of Figures 2, 3 and 7,  $C_{LOAD} = 15$  pF, driver output impedance  $\leq 50$   $\Omega$ ,  $R_{LOAD} = 1$  M $\Omega$ , unless otherwise specified)

Symbol	Parameter	Conditions	-40 °C to +85 °C						Unit
			$V_{CC} = 2.3$ to $2.7$ V		$V_{CC} = 3.0$ to $3.6$ V		$V_{CC} = 4.5$ to $5.5$ V		
			Min	Max	Min	Max	Min	Max	

### $V_L = 1.65$ to $1.95$ V

$t_{RVL}$	I/O $V_L$ Rise Time	Figure 8	0.6	9.5	2.3	12.5	0.8	7.6	nS
$t_{RVCC}$	I/O $V_{CC}$ Rise Time	Figure 8	4.0	10.8	2.7	9.1	2.7	7.6	nS
$t_{FVL}$	I/O $V_L$ Fall Time	Figure 8	2.0	9.7	1.9	8.1	1.7	13.3	nS
$t_{FVCC}$	I/O $V_{CC}$ Fall Time	Figure 8	2.9	13.8	2.8	16.2	2.8	16.2	nS
$t_{PHL-VL-VCC}$	Propagation Delay (Driving I/O $V_L$ , $V_L$ to $V_{CC}$ )	Figure 2		5.6		7.1		6.8	nS
$t_{PLH-VL-VCC}$				6.5		7.1		7.4	
$t_{PHL-VCC-VL}$	Propagation Delay (Driving I/O $V_{CC}$ , $V_{CC}$ to $V_L$ )	Figure 3		4.8		5.3		2.0	nS
$t_{PLH-VCC-VL}$				4.8		5.0		3.5	
$t_{EN}$	Enable Time	Figure 7		50		40		35	nS
$t_{DIS}$	Disable Time	Figure 7		316		225		215	nS
$t_{PPSKEW}$	Part-to-Part Skew			0.7		0.7		0.7	nS
MDR	Maximum Data Rate		21		22		24		Mbps

### $V_L = 2.3$ to $2.7$ V

$t_{RVL}$	I/O $V_L$ Rise Time	Figure 8	2.8	7.7	2.6	8.1	1.8	10.3	nS
$t_{RVCC}$	I/O $V_{CC}$ Rise Time	Figure 8	3.2	9.2	2.9	8.8	2.4	6.4	nS
$t_{FVL}$	I/O $V_L$ Fall Time	Figure 8	1.9	8.3	1.9	7.8	1.8	7.4	nS
$t_{FVCC}$	I/O $V_{CC}$ Fall Time	Figure 8	2.2	8.3	2.4	8.0	2.6	10.0	nS
$t_{PHL-VL-VCC}$	Propagation Delay (Driving I/O $V_L$ , $V_L$ to $V_{CC}$ )	Figure 2		3.2		3.7		3.9	nS
$t_{PLH-VL-VCC}$				4.8		5.3		6.0	
$t_{PHL-VCC-VL}$	Propagation Delay (Driving I/O $V_{CC}$ , $V_{CC}$ to $V_L$ )	Figure 3		2.5		1.6		1.0	nS
$t_{PLH-VCC-VL}$				4.5		4.3		3.4	
$t_{EN}$	Enable Time	Figure 7		50		40		35	nS
$t_{DIS}$	Disable Time	Figure 7		225		225		215	nS
$t_{PPSKEW}$	Part-to-Part Skew			0.7		0.7		0.7	nS
MDR	Maximum Data Rate		20		22		24		Mbps

# NLSX0102

## Timing Characteristics – Rail-to-Rail Driving Configuration

(I/O test circuits of Figures 2, 3 and 7,  $C_{LOAD} = 15 \text{ pF}$ , driver output impedance  $\leq 50 \Omega$ ,  $R_{LOAD} = 1 \text{ M}\Omega$ , unless otherwise specified)

Symbol	Parameter	Conditions	-40°C to +85°C						Unit
			V <sub>CC</sub> = 2.3 to 2.7 V		V <sub>CC</sub> = 3.0 to 3.6 V		V <sub>CC</sub> = 4.5 to 5.5 V		
			Min	Max	Min	Max	Min	Max	

V<sub>L</sub> = 3.0 to 3.6 V

t <sub>RVL</sub>	I/O V <sub>L</sub> Rise Time	Figure 8			2.3	6.5	1.9	8.0	nS
t <sub>RVCC</sub>	I/O V <sub>CC</sub> Rise Time	Figure 8			2.5	6.5	2.1	7.4	nS
t <sub>FVL</sub>	I/O V <sub>L</sub> Fall Time	Figure 8			2.0	7.2	1.9	5.9	nS
t <sub>FVCC</sub>	I/O V <sub>CC</sub> Fall Time	Figure 8			2.3	8.0	2.4	9.3	nS
t <sub>PHL-VL-VCC</sub>	Propagation Delay (Driving I/O V <sub>L</sub> , V <sub>L</sub> to V <sub>CC</sub> )	Figure 2				2.4		3.1	nS
t <sub>PLH-VL-VCC</sub>						3.8		3.8	
t <sub>PHL-VCC-VL</sub>	Propagation Delay (Driving I/O V <sub>CC</sub> , V <sub>CC</sub> to V <sub>L</sub> )	Figure 3				2.5		2.6	nS
t <sub>PLH-VCC-VL</sub>						3.6		3.1	
t <sub>EN</sub>	Enable Time	Figure 7				40		35	nS
t <sub>DIS</sub>	Disable Time	Figure 7				225		235	nS
t <sub>PPSKEW</sub>	Part-to-Part Skew					0.7		0.7	nS
MDR	Maximum Data Rate				23		24		Mbps

## Timing Characteristics – Open Drain Driving Configuration

(I/O test circuits of Figures 4, 5 and 7,  $C_{LOAD} = 15 \text{ pF}$ , driver output impedance  $\leq 50 \Omega$ ,  $R_{LOAD} = 1 \text{ M}\Omega$ , unless otherwise specified)

Symbol	Parameter	Conditions	-40°C to +85°C						Unit
			V <sub>CC</sub> = 2.3 to 2.7 V		V <sub>CC</sub> = 3.0 to 3.6 V		V <sub>CC</sub> = 4.5 to 5.5 V		
			Min	Max	Min	Max	Min	Max	

V<sub>L</sub> = 1.65 to 1.95 V

t <sub>RVL</sub>	I/O V <sub>L</sub> Rise Time	Figure 8	38	340	30	245	22.0	134	nS
t <sub>RVCC</sub>	I/O V <sub>CC</sub> Rise Time	Figure 8	34	330	23	218	10.0	120	nS
t <sub>FVL</sub>	I/O V <sub>L</sub> Fall Time	Figure 8	4.4	11.1	4.3	12.0	4.2	14.2	nS
t <sub>FVCC</sub>	I/O V <sub>CC</sub> Fall Time	Figure 8	6.9	11	7.5	16.2	7.0	16.2	nS
t <sub>PHLVL-VCC</sub>	Propagation Delay (Driving I/O V <sub>L</sub> , V <sub>L</sub> to V <sub>CC</sub> )	Figure 2	2.3	27	2.4	20.0	2.6	23.0	nS
t <sub>PLHVL-VCC</sub>			45	260	36.0	208	27.0	208	
t <sub>PHLVCC-VL</sub>	Propagation Delay (Driving I/O V <sub>CC</sub> , V <sub>CC</sub> to V <sub>L</sub> )	Figure 3	1.9	22	1.1	22.0	1.2	22.0	nS
t <sub>PLHVCC-VL</sub>			45.0	200	36	150	27.0	112	
t <sub>EN</sub>	Enable Time	Figure 7		80		70		35	nS
t <sub>DIS</sub>	Disable Time	Figure 7		250		277		290	nS
t <sub>PPSKEW</sub>	Part-to-Part Skew			0.7		0.7		0.7	nS
MDR	Maximum Data Rate		2		2		2		Mbps

# NLSX0102

## Timing Characteristics – Open Drain Driving Configuration

(I/O test circuits of Figures 4, 5 and 7,  $C_{LOAD} = 15 \text{ pF}$ , driver output impedance  $\leq 50 \Omega$ ,  $R_{LOAD} = 1 \text{ M}\Omega$ , unless otherwise specified)

Symbol	Parameter	Conditions	-40°C to +85°C						Unit
			V <sub>CC</sub> = 2.3 to 2.7 V		V <sub>CC</sub> = 3.0 to 3.6 V		V <sub>CC</sub> = 4.5 to 5.5 V		
			Min	Max	Min	Max	Min	Max	

### V<sub>L</sub> = 2.3 to 2.7 V

t <sub>RVL</sub>	I/O V <sub>L</sub> Rise Time	Figure 8	34	400	28.0	300	24.0	208	nS
t <sub>RVCC</sub>	I/O V <sub>CC</sub> Rise Time	Figure 8	35.0	352	24.0	280	12.0	180	nS
t <sub>FVL</sub>	I/O V <sub>L</sub> Fall Time	Figure 8	4.4	6.9	4.3	6.2	4.2	7.8	nS
t <sub>FVCC</sub>	I/O V <sub>CC</sub> Fall Time	Figure 8	4.3	8.8	4.9	9.4	5.4	10.4	nS
t <sub>PHLVL-VCC</sub>	Propagation Delay (Driving I/O V <sub>L</sub> , V <sub>L</sub> to V <sub>CC</sub> )	Figure 2	1.7	14.0	2.0	14.0	2.1	14.0	nS
t <sub>PLHVL-VCC</sub>			43.0	250	36.0	210	27.0	210	
t <sub>PHLVCC-VL</sub>	Propagation Delay (Driving I/O V <sub>CC</sub> , V <sub>CC</sub> to V <sub>L</sub> )	Figure 3	1.8	13.0	2.6	13.0	1.2	13.0	nS
t <sub>PLHVCC-VL</sub>			44.0	225	37.0	180	27.0	144	
t <sub>EN</sub>	Enable Time	Figure 7		50		40		35	nS
t <sub>DIS</sub>	Disable Time	Figure 7		265		230		215	nS
t <sub>PPSKEW</sub>	Part-to-Part Skew			0.7		0.7		0.7	nS
MDR	Maximum Data Rate		2		2		2		Mbps

### V<sub>L</sub> = 3.0 to 3.6 V

t <sub>RVL</sub>	I/O V <sub>L</sub> Rise Time	Figure 8			25.0	400	19.0	278	nS
t <sub>RVCC</sub>	I/O V <sub>CC</sub> Rise Time	Figure 8			26.0	375	14.0	247	nS
t <sub>FVL</sub>	I/O V <sub>L</sub> Fall Time	Figure 8			2.8	6.1	2.6	5.7	nS
t <sub>FVCC</sub>	I/O V <sub>CC</sub> Fall Time	Figure 8			2.6	7.6	3.1	8.3	nS
t <sub>PHLVL-VCC</sub>	Propagation Delay (Driving I/O V <sub>L</sub> , V <sub>L</sub> to V <sub>CC</sub> )	Figure 2			1.3	10.0	1.4	8.0	nS
t <sub>PLHVL-VCC</sub>					36.0	255	28.0	243	
t <sub>PHLVCC-VL</sub>	Propagation Delay (Driving I/O V <sub>CC</sub> , V <sub>CC</sub> to V <sub>L</sub> )	Figure 3			1.0	124	1.0	97.0	nS
t <sub>PLHVCC-VL</sub>					3.0	185	3.0	136	
t <sub>EN</sub>	Enable Time	Figure 7				40		35	nS
t <sub>DIS</sub>	Disable Time	Figure 7				250		205	nS
t <sub>PPSKEW</sub>	Part-to-Part Skew					0.7		0.7	nS
MDR	Maximum Data Rate				2		2		Mbps

# NLSX0102

## TEST SETUPS

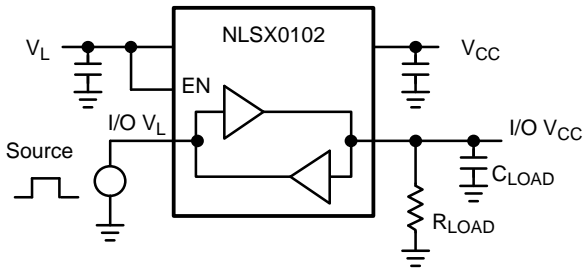

Figure 2. Rail-to-Rail Driving I/O  $V_L$

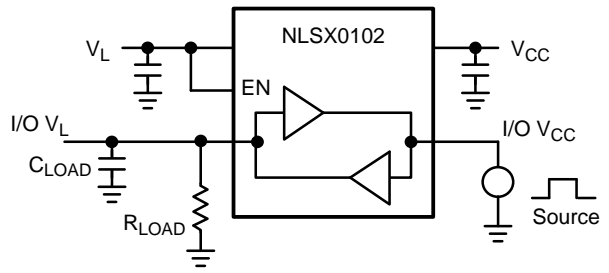

Figure 3. Rail-to-Rail Driving I/O  $V_{CC}$

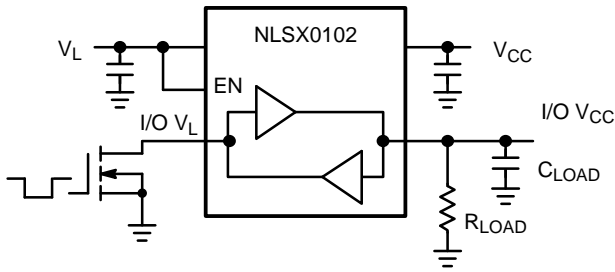

Figure 4. Open-Drain Driving I/O  $V_L$

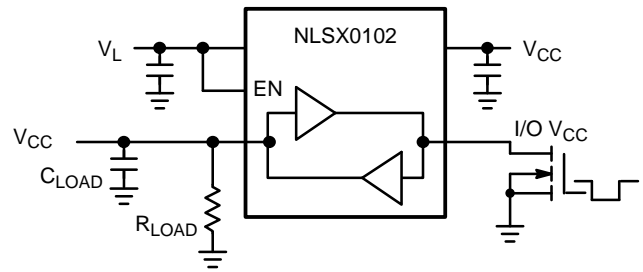

Figure 5. Open-Drain Driving I/O  $V_{CC}$

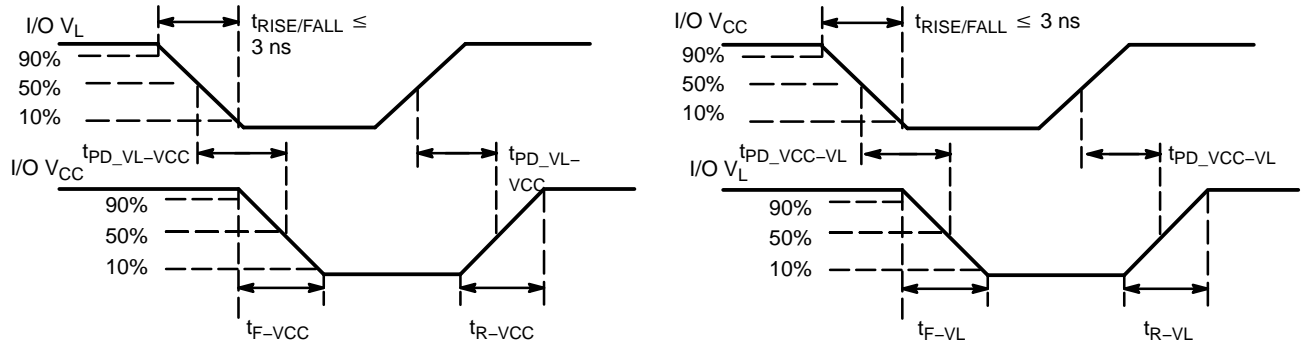

Figure 6. Definition of Timing Specification Parameters



# NLSX0102

## APPLICATIONS INFORMATION

### Level Translator Architecture

The NLSX0102 auto sense translator provides bi-directional voltage level shifting to transfer data in multiple supply voltage systems. This device has two supply voltages,  $V_L$  and  $V_{CC}$ , which set the logic levels on the input and output sides of the translator. When used to transfer data from the  $V_L$  to the  $V_{CC}$  ports, input signals referenced to the  $V_L$  supply are translated to output signals with a logic level matched to  $V_{CC}$ . In a similar manner, the  $V_{CC}$  to  $V_L$  translation shifts input signals with a logic level compatible to  $V_{CC}$  to an output signal matched to  $V_L$ .

The NLSX0102 consists of two bi-directional channels that independently determine the direction of the data flow without requiring a directional pin. The one-shot circuits are used to detect the rising or falling input signals. In addition, the one shots decrease the rise and fall time of the output signal for high-to-low and low-to-high transitions. Each input/output channel has an internal 10 k $\Omega$  pull-up. The magnitude of the pull-up resistors can be reduced by connecting external resistors in parallel to the internal 10 k $\Omega$  resistors.

### Input Driver Requirements

The rise ( $t_R$ ) and fall ( $t_F$ ) timing parameters of the open drain outputs depend on the magnitude of the pull-up resistors. In addition, the propagation times ( $t_{PD}$ ), skew ( $t_{PSKEW}$ ) and maximum data rate depend on the impedance

of the device that is connected to the translator. The timing parameters listed in the data sheet assume that the output impedance of the drivers connected to the translator is less than 50 k $\Omega$ .

### Enable Input (EN)

The NLSX0102 has an Enable pin (EN) that provides tri-state operation at the I/O pins. Driving the Enable pin to a low logic level minimizes the power consumption of the device and drives the I/O  $V_{CC}$  and I/O  $V_L$  pins to a high impedance state. Normal translation operation occurs when the EN pin is equal to a logic high signal. The EN pin is referenced to the  $V_L$  supply and has Overvoltage Tolerant (OVT) protection.

### Power Supply Guidelines

During normal operation, supply voltage  $V_L$  can be greater than, less than or equal to  $V_{CC}$ . The sequencing of the power supplies will not damage the device during the power up operation. For optimal performance, 0.01  $\mu$ F to 0.1  $\mu$ F decoupling capacitors should be used on the  $V_L$  and  $V_{CC}$  power supply pins. Ceramic capacitors are a good design choice to filter and bypass any noise signals on the voltage lines to the ground plane of the PCB. The noise immunity will be maximized by placing the capacitors as close as possible to the supply and ground pins, along with minimizing the PCB connection traces.

## ORDERING INFORMATION

Device	Package	Shipping†
NLSX0102FCT1G	Flip-Chip 8 (Pb-Free)	3000 / Tape & Reel
NLSX0102FCT2G	Flip-Chip 8 (Pb-Free)	3000 / Tape & Reel (4mm Pitch Carrier Tape)
NLSX0102FC2T2G	Flip-Chip 8 (Pb-Free)	3000 / Tape & Reel (2mm Pitch Carrier Tape)

†For information on tape and reel specifications, including part orientation and tape sizes, please refer to our Tape and Reel Packaging Specifications Brochure, BRD8011/D.

# NLSX0102

## PACKAGE DIMENSIONS

### 8 PIN FLIP-CHIP, 0.9x1.9, 0.5P CASE 499BF ISSUE O

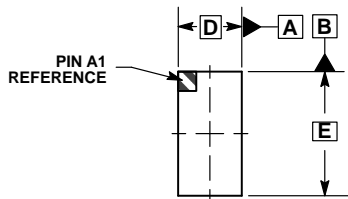

TOP VIEW

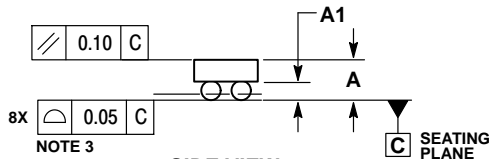

SIDE VIEW

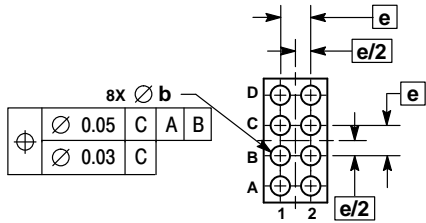

BOTTOM VIEW

NOTES:

1. DIMENSIONING AND TOLERANCING PER ASME Y14.5M, 1994.
2. CONTROLLING DIMENSION: MILLIMETERS.
3. COPLANARITY APPLIES TO SPHERICAL CROWNS OF SOLDER BALLS.

MILLIMETERS		
DIM	MIN	MAX
A	0.44	0.50
A1	0.15	0.19
b	0.21	0.25
D	0.90 BSC	
E	1.90 BSC	
e	0.50 BSC	

### SOLDERING FOOTPRINT\*

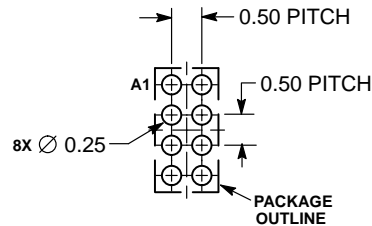

\*For additional information on our Pb-Free strategy and soldering details, please download the ON Semiconductor Soldering and Mounting Techniques Reference Manual, SOLDERRM/D.

ON Semiconductor and are trademarks of Semiconductor Components Industries, LLC dba ON Semiconductor or its subsidiaries in the United States and/or other countries. ON Semiconductor owns the rights to a number of patents, trademarks, copyrights, trade secrets, and other intellectual property. A listing of ON Semiconductor's product/patent coverage may be accessed at [www.onsemi.com/site/pdf/Patent-Marking.pdf](http://www.onsemi.com/site/pdf/Patent-Marking.pdf). ON Semiconductor reserves the right to make changes without further notice to any products herein. ON Semiconductor makes no warranty, representation or guarantee regarding the suitability of its products for any particular purpose, nor does ON Semiconductor assume any liability arising out of the application or use of any product or circuit, and specifically disclaims any and all liability, including without limitation special, consequential or incidental damages. Buyer is responsible for its products and applications using ON Semiconductor products, including compliance with all laws, regulations and safety requirements or standards, regardless of any support or applications information provided by ON Semiconductor. "Typical" parameters which may be provided in ON Semiconductor data sheets and/or specifications can and do vary in different applications and actual performance may vary over time. All operating parameters, including "Typicals" must be validated for each customer application by customer's technical experts. ON Semiconductor does not convey any license under its patent rights nor the rights of others. ON Semiconductor products are not designed, intended, or authorized for use as a critical component in life support systems or any FDA Class 3 medical devices or medical devices with a same or similar classification in a foreign jurisdiction or any devices intended for implantation in the human body. Should Buyer purchase or use ON Semiconductor products for any such unintended or unauthorized application, Buyer shall indemnify and hold ON Semiconductor and its officers, employees, subsidiaries, affiliates, and distributors harmless against all claims, costs, damages, and expenses, and reasonable attorney fees arising out of, directly or indirectly, any claim of personal injury or death associated with such unintended or unauthorized use, even if such claim alleges that ON Semiconductor was negligent regarding the design or manufacture of the part. ON Semiconductor is an Equal Opportunity/Affirmative Action Employer. This literature is subject to all applicable copyright laws and is not for resale in any manner.

### PUBLICATION ORDERING INFORMATION

**LITERATURE FULFILLMENT:**

Literature Distribution Center for ON Semiconductor  
19521 E. 32nd Pkwy, Aurora, Colorado 80011 USA  
Phone: 303-675-2175 or 800-344-3860 Toll Free USA/Canada  
Fax: 303-675-2176 or 800-344-3867 Toll Free USA/Canada  
Email: [orderlit@onsemi.com](mailto:orderlit@onsemi.com)

**N. American Technical Support:** 800-282-9855 Toll Free  
USA/Canada  
**Europe, Middle East and Africa Technical Support:**  
Phone: 421 33 790 2910

**ON Semiconductor Website:** [www.onsemi.com](http://www.onsemi.com)  
**Order Literature:** <http://www.onsemi.com/orderlit>

For additional information, please contact your local Sales Representative

## Looking for pricing, stock, or lifecycle information?

Click below to explore more details on WIN SOURCE:

 [View NLSX0102FCT1G on WIN SOURCE](#)

 [ON Semiconductor](#) Information

## Optimize Your Supply Chain with WIN SOURCE Solutions

-  Global Sourcing Solution
-  Obsolete Management
-  Cost Control Management
-  Shortage Management
-  Alternative Solution
-  Excess Inventory Management