



**THE DATASHEET OF
ISL99140IRZ-T**



ISL99140

40A DrMOS Power Module with Integrated Diode Emulation and Thermal Warning Output

FN8642
Rev.2.00
Jul 20, 2017

The [ISL99140](#) is a high performance DrMOS power module designed for high frequency power conversion. By combining a high performance FET driver and MOSFETs in an advanced package, high density DC/DC converters can be created. Combined with an Intersil PWM controller, a complete voltage regulator solution can be created with reduced external components and minimum overall PCB real estate.

The ISL99140 features a three-state PWM input that, working together with Intersil’s multiphase PWM controllers, will provide a robust solution in the event of abnormal operating conditions. To further support robust applications, the ISL99140 features a thermal warning output that can be used to notify the power system of an impending thermal fail event.

The ISL99140 supports high efficiency operation not only at heavy loads, but also at light loads through its diode emulation capability. Diode emulation can be disabled for those applications in which variable frequency operation is not desired at light loads.

Related Literature

- For a full list of related documents, visit our website - [ISL99140](#) product page

Features

- Compliant with Intel DrMOS revision 4.0 specifications
- 40A average output current capability
- Supports 3-state 3.3V PWM input
- Supports 2-state 5V PWM input
- Thermal warning output
- Diode emulation option
- Adaptive shoot-through protection
- Integrated high-side gate-to-source resistor to prevent self turn-on due to high input bus dV/dt
- Undervoltage lockout
- Switching frequencies up to 2MHz
- Pb-free (RoHS compliant)
- 6x6 QFN package

Applications

- High frequency and high efficiency VRM and VRD
- Core, graphic, and memory regulators for microprocessors
- High density VR for server, networking, and cloud computing
- POL DC/DC converters and video gaming consoles

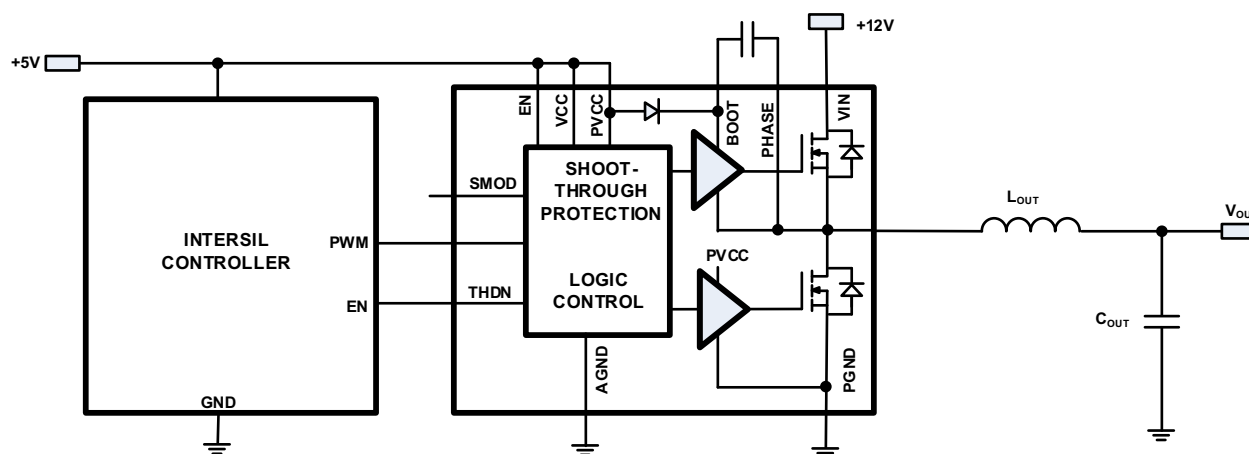

FIGURE 1. SIMPLIFIED APPLICATION BLOCK DIAGRAM

Ordering Information

PART NUMBER (Notes 1, 2, 3)	PART MARKING	TEMP RANGE (°C)	TAPE AND REEL QUANTITY (UNITS)	PACKAGE (RoHS Compliant)	PKG. DWG. #
ISL99140IRZ-T	99140 IRZ	-40 to +85	3k	40 Ld Exposed Pad 6x6 QFN	L40.6x6A

NOTES:

1. Refer to [TB347](#) for details on reel specifications.
2. These Intersil Pb-free plastic packaged products employ special Pb-free material sets, molding compounds/die attach materials, and 100% matte tin plate plus anneal (e3 termination finish, which is RoHS compliant and compatible with both SnPb and Pb-free soldering operations). Intersil Pb-free products are MSL classified at Pb-free peak reflow temperatures that meet or exceed the Pb-free requirements of IPC/JEDEC J STD-020.
3. For Moisture Sensitivity Level (MSL), see the product information page for [ISL99140](#). For more information on MSL, see [TB363](#).

TABLE 1. KEY DIFFERENCES BETWEEN FAMILY OF PARTS

PART #	CURRENT RATING (A)	PWM (V)	THERMAL FLAG	OCP FLAG	IMON	TMON	PACKAGE DWG. #	P2P COMPATIBLE	USED WITH
5.0V PWM POWER STAGE FAMILY									
ISL99125B	25	5.0	No	No	No	No	L24.3.5x5W	ISL99135B	Analog Controllers: ISL633x, ISL636x, ISL637x, ISL95829, ISL9585x Digital Hybrid Controllers: ISL68201, ISL6388/98 Full Digital Controller: ZL8802 Phase Doublers: ISL6617, ISL6617A
ISL99135B	35	5.0	No	No	No	No	L24.3.5x5W	ISL99125B	
ISL99227B	60	5.0	Yes	Yes	Yes	Yes	L32.5x5V	N/A	
3.3V PWM POWER STAGE FAMILY									
ISL99140	40	3.3	Yes	No	No	No	L40.6x6A	N/A	Full Digital Controllers: ISL68/69xxx, ZL8802 Digital Hybrid Controllers: ISL68201, ISL6388/98 (3.3V PWM Setting)
ISL99227	60	3.3	Yes	Yes	Yes	Yes	L32.5x5V	N/A	

Functional Block Diagram

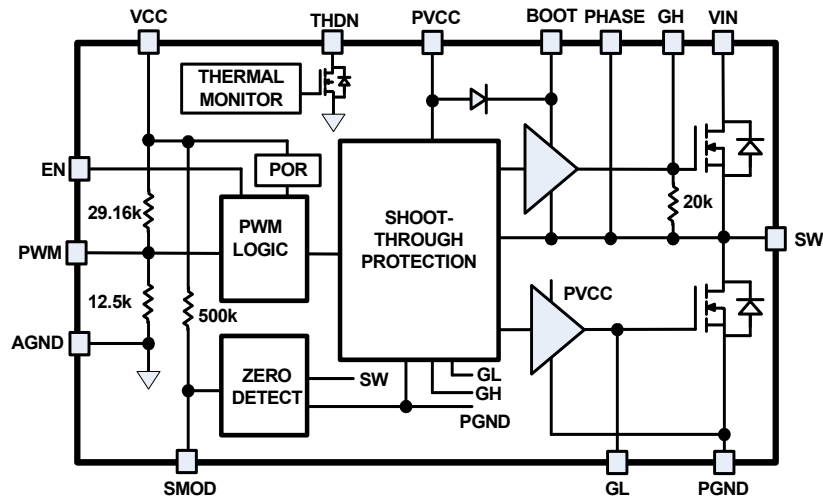
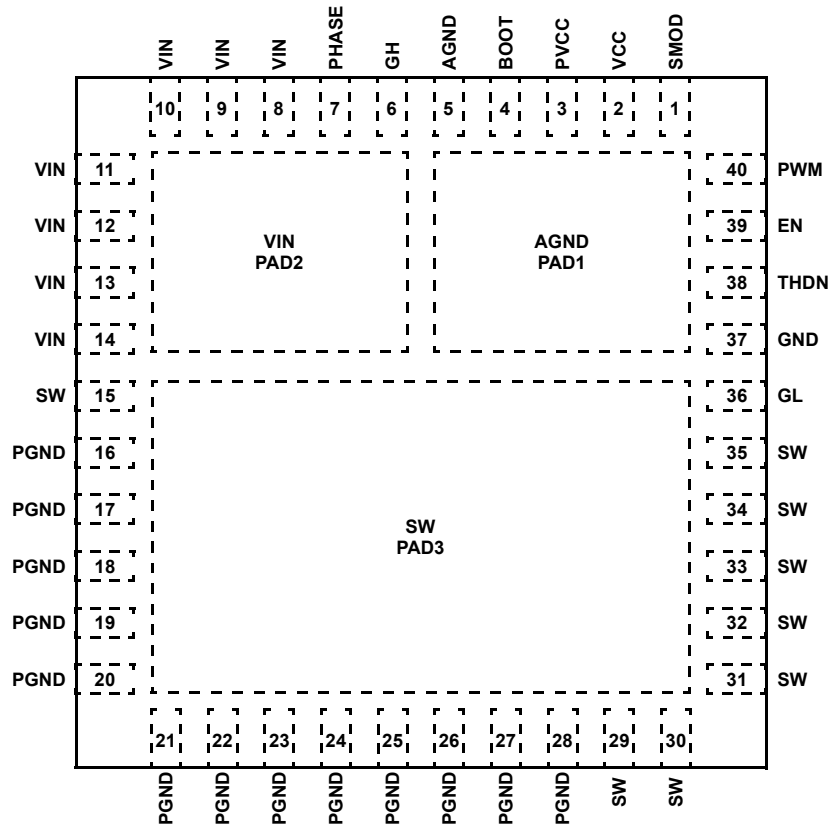

FIGURE 2. FUNCTIONAL BLOCK DIAGRAM

Pin Configuration

ISL99140
(40 LD QFN)
TOP VIEW



Pin Descriptions

PIN NUMBER	PIN NAME	DESCRIPTION
1	SMOD	Input pin to enable or disable diode emulation with built-in pull up of 10 μ A. When SMOD is LOW, diode emulation is allowed. Otherwise, continuous conduction mode is forced.
2	VCC	+5V logic bias supply. Place a high quality low ESR ceramic capacitor from this pin to GND.
3	PVCC	+5V driver bias supply. Place a high quality low ESR ceramic capacitor from this pin to GND. VCC and PVCC often share the decoupling capacitor (~1 μ F/0402~0603/ X5R~X7R).
4	BOOT	Floating bootstrap supply pin for the upper gate drive. Place a high quality low ESR ceramic capacitor (~0.1 μ F to 0.22 μ F) in close proximity across the BOOT and PHASE pins. A series resistor (typically 1.5 to 3.9 Ω) with a bootstrap capacitor is optional, but recommended for high input voltage applications.
5, 37, PAD1	AGND, GND	Return of logic bias supply VCC. Connect directly to the system ground plane.
6	GH	High-side gate drive output for monitoring/testing. No circuit connection needed.
7	PHASE	Return of bootstrap capacitor. Internally connected to SW node. External connection is not needed.
8, 9, 10, 11, 12, 13, 14, PAD2	VIN	Input of Power Stage. Place couple high quality low ESR ceramic capacitor (couple 10 μ F or higher, X7R) and a high frequency decoupling capacitor (0.1 μ F to 1 μ F) in close proximity across the VIN and GND planes.
16, 17, 18, 19, 20, 21, 22, 23, 24, 25, 26, 27, 28	PGND	Power Stage return. Connect directly to the system ground plane.
15, 29, 30, 31, 32, 33, 34, 35, PAD3	SW	Switching junction node between low and high-side MOSFETs. Connect directly to the output inductor.
36	GL	Low-side gate drive output for monitoring/testing. No circuit connection needed.
38	THDN	Thermal warning flag, an output open-drain pin. High = Normal operation; Low = Shutdown.
39	EN	Enable input pin with 2 μ A internal weak pull-down. High = Enable; Low = Disable.
40	PWM	PWM input of gate driver. The PWM signal can enter three distinct states during operation. Connect this pin to the PWM output of the controller.

Typical Application Circuits

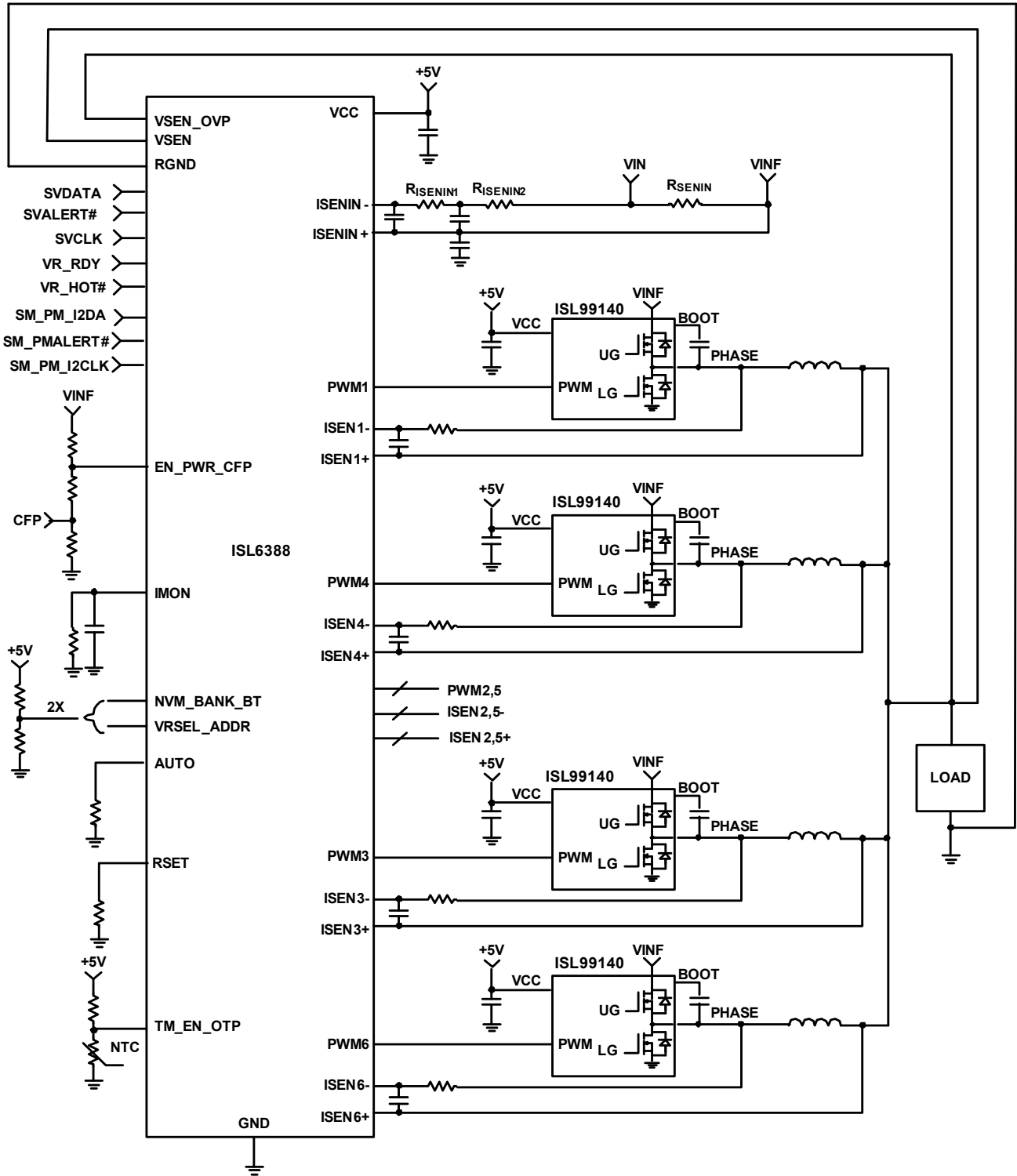

FIGURE 3. TYPICAL APPLICATION CIRCUIT WITH ISL6388

Typical Application Circuits (Continued)

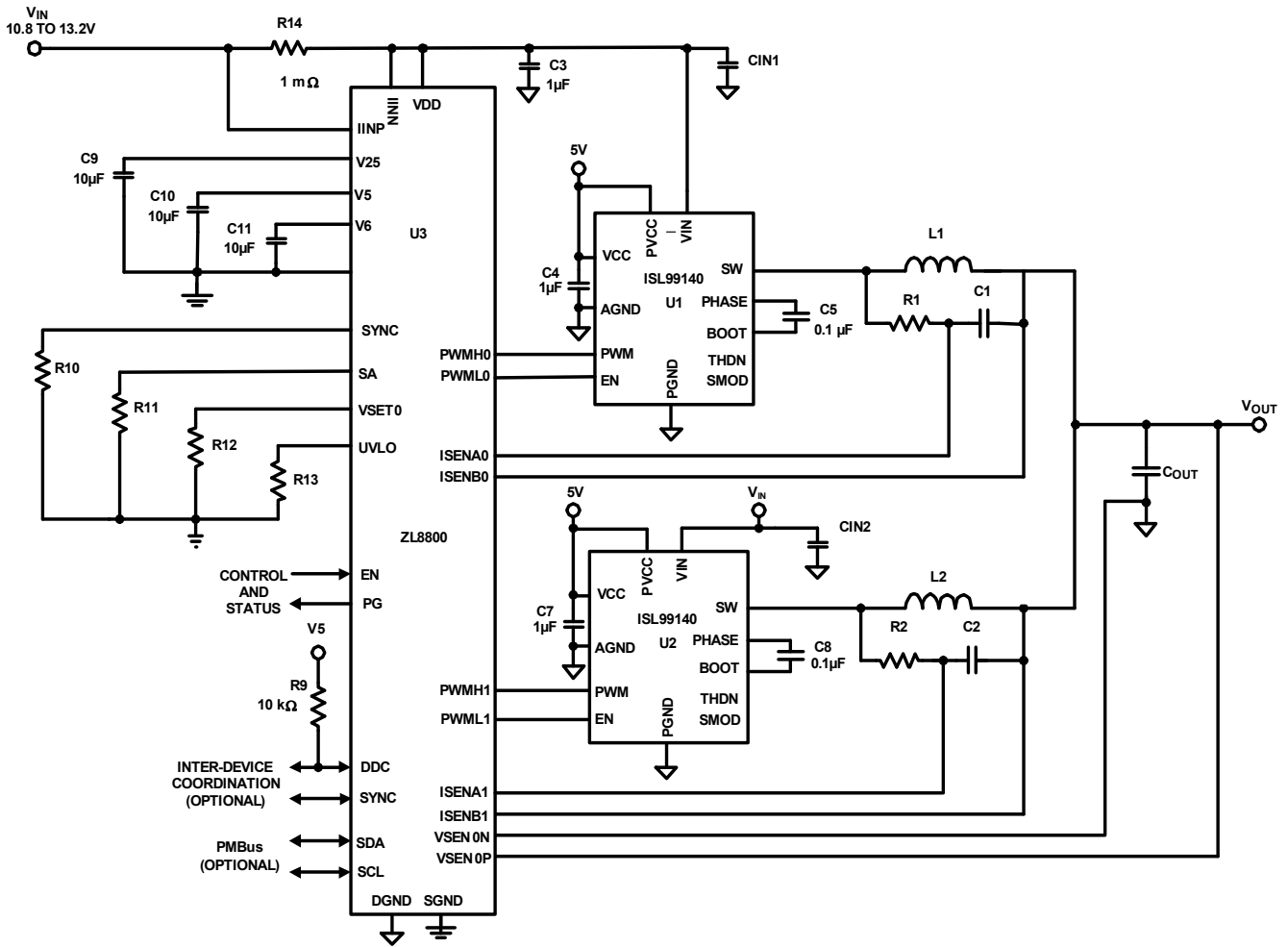

FIGURE 4. TYPICAL APPLICATION CIRCUIT WITH ZL8800

Absolute Maximum Ratings

Continuous Current (Notes 8)	40A
VIN	-0.3V to 30V
Supply Voltage (VCC)	-0.3V to 7V
I/O Voltage (VEN, VPWM, VSMOD, VTHDN)	-0.3V to VCC + 0.3V
BOOT Voltage (VBOOT-GND)	-0.3V to 25V (DC) or 36V (<200ns)
BOOT TO PHASE Voltage (VBOOT-PHASE)	-0.3V to 7V (DC)
	-0.3V to 9V (<10ns)
PHASE Voltage	(GND - 0.3V) to 30V
	(GND - 10V) (<20ns Pulse Width, 10μJ)

Thermal Information

Thermal Resistance	θ_{JA} (°C/W)	θ_{JC} (°C/W)
40 Ld 6x6 QFN Package (Notes 4, 5, 7)	14.5	5
Maximum Junction Temperature (Plastic Package)	+150°C	
Maximum Storage Temperature Range	-65°C to +150°C	
Pb-Free Reflow Profile	see TB493	

Recommended Operating Conditions

Ambient Temperature Range	-40°C to +85°C
Maximum Operating Junction Temperature	+125°C
Supply Voltage, VCC, PVCC	5V ±5%
Input Supply Voltage, VIN (Notes 9)	0V to 20V

CAUTION: Do not operate at or near the maximum ratings listed for extended periods of time. Exposure to such conditions may adversely impact product reliability and result in failures not covered by warranty.

NOTES:

- θ_{JA} is measured in free air with the component mounted on an Intersil evaluation board with "direct attach" features. Refer to [TB379](#) for general thermal metric information.
- For θ_{JC} , the "case temp" location is the center of the exposed metal pad on the package underside.
- Jedec Class II pulse conditions and failure criterion used.
- These ratings vary with PCB layout and operating conditions.
- Limited to power dissipation, thermal management solution, junction temperature, and over-temperature trip point for continuous operation; lower power dissipation and better cooling design allow higher continuous current.
- A tightly decoupling loop across VIN and PGND with input ceramics capacitors is required. See "[PCB Layout Considerations](#)" on page 10 for details. A resistor in series (typically 1.5 to 3.9Ω) with a bootstrap capacitor is optional, but recommended for high input voltage applications to prevent exceeding the absolute maximum ratings of the device.

Electrical Specifications $T_A = +25^\circ\text{C}$; $V_{IN} = 12\text{V}$, $V_{VCC} = V_{PVCC} = 5\text{V}$ unless otherwise noted. Boldface limits apply across the recommended operating temperature range.

PARAMETER	SYMBOL	TEST CONDITIONS	MIN (Note 10)	TYP	MAX (Note 10)	UNIT
SUPPLY CURRENT						
VCC Standby Supply Bias Current	I _{VCC}	EN = Low, V _{VCC} = 5V		187		μA
		EN = High, V _{PWM} = Open		467		μA
		EN = High, V _{PWM} = 0V		664		μA
PVCC Supply Bias Current	I _{PVCC}	EN = High, V _{PWM} = 300kHz, 50% duty cycle		23		mA
		EN = High, V _{PWM} = 1MHz, 50% duty cycle		51		mA
POWER-ON RESET AND ENABLE						
POR Rising Threshold	V _{PORR}			3.40	3.90	V
POR Falling Threshold	V _{PORF}		2.3	2.92		V
POR Hysteresis	V _{PORH}			570		mV
EN High Threshold	V _{ENH}		2.0			V
EN Low Threshold	V _{ENL}				0.8	V
EN Pull-Down Current	I _{ENL}			2		μA
PWM INPUT						
Pull-Up Impedance				29.1		kΩ
Pull-Down Impedance				12.5		kΩ
PWM Rising Threshold	V _{PWMH}	V _{VCC} = 5V	1.70	2.05	2.35	V
PWM Falling Threshold	V _{PWML}	V _{VCC} = 5V	0.75	1.00	1.25	V
PWM Tri-State Rising Threshold	V _{TRIH}	V _{VCC} = 5V	1.10	1.32	1.50	V

Electrical Specifications $T_A = +25^\circ\text{C}$; $V_{IN} = 12\text{V}$, $V_{VCC} = V_{PVCC} = 5\text{V}$ unless otherwise noted. **Boldface limits apply across the recommended operating temperature range. (Continued)**

PARAMETER	SYMBOL	TEST CONDITIONS	MIN (Note 10)	TYP	MAX (Note 10)	UNIT
PWM Tri-State Falling Threshold	V_{TRIL}	$V_{VCC} = 5\text{V}$	1.60	1.75	1.95	V
PWM Tri-State Rising Hysteresis	V_{TRRH}	$V_{VCC} = 5\text{V}$		310		mV
PWM Tri-State Falling Hysteresis	V_{TRFH}	$V_{VCC} = 5\text{V}$		310		mV
SWITCHING TIME						
GH Turn-On Propagation Delay	t_{PDHU}	$V_{VCC} = 5\text{V}$, see Figure 5 (GL Low to GH High)		15		ns
GH Turn-Off Propagation Delay	t_{PDLU}	$V_{VCC} = 5\text{V}$, see Figure 5 (PWM Low to GH Low)		18		ns
GL Turn-On Propagation Delay	t_{PDHL}	$V_{VCC} = 5\text{V}$, see Figure 5 (GH Low to GL High)		20		ns
GL Turn-Off Propagation Delay	t_{PDLL}	$V_{VCC} = 5\text{V}$, see Figure 5 (PWM High to GL Low)		18		ns
GH/GL Exit Tri-State Propagation Delay	t_{PDTS}	$V_{VCC} = 5\text{V}$, see Figure 5 (Tri-State to GH/GL High)		20		ns
Tri-State Shutdown Hold-Off Time	t_{TSSHD}	$V_{VCC} = 5\text{V}$, see Figure 5	75	150	225	ns
Minimum GL On-Time in DCM	t_{LGMIN}	$V_{VCC} = 5\text{V}$		350		ns
SMOD INPUT						
SMOD High Threshold	V_{SMODH}		2.0			V
SMOD Low Threshold	V_{SMODL}				0.8	V
SMOD Pin Pull-Up Current	ISMOD			10		μA
THERMAL SHUTDOWN (THDN)						
Pull-Down Impedance		1mA		60		Ω
Output Low		1mA		70		mV
Thermal Shutdown Flag Set		(Note 11)		150		$^\circ\text{C}$
Thermal Shutdown Flag Clear		(Note 11)		135		$^\circ\text{C}$
Hysteresis		(Note 11)		15		$^\circ\text{C}$

NOTES:

10. Parameters with MIN and/or MAX limits are 100% tested at $+25^\circ\text{C}$, unless otherwise specified. Temperature limits established by characterization and are not production tested.
11. Limits established by characterization and are not production tested.

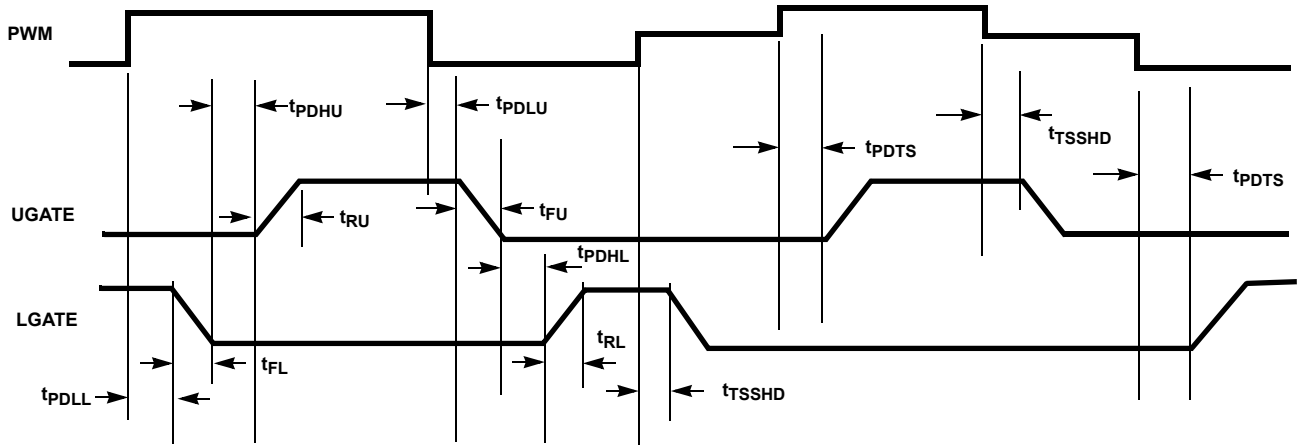

FIGURE 5. TIMING DIAGRAM

TABLE 2. GATE DRIVE TRUTH TABLE

ENABLE	SMOD	PWM	GL	GH
L	X	X	L	L
H	L	L	H (Note 12)	L
H	L	H	L	H
H	H	L	H	L
H	H	H	L	H

NOTE:

12. The GL stays high until the inductor current drops to zero.

Operation

The ISL99140 is an optimized driver and power stage solution for high density synchronous DC/DC power conversion. The ISL99140 includes a high performance driver, integrated Schottky bootstrap diode, and MOSFET pair optimized for high switching frequency buck voltage regulators. The ISL99140 includes a driver with advanced power management features that allow direct control of the Lower MOSFET, diode emulation, and thermal protection.

Power-On Reset (POR) and EN

During initial start-up, the V_{CC} voltage rise is monitored. When the rising V_{CC} voltage exceeds 3.40V (typically), normal operation of the driver is enabled. If V_{CC} drops below the falling threshold of 2.92V (typically), operation of the driver is disabled.

If the EN pin is pulled low, the driver will immediately force both MOSFETs to their off states. This action does not depend on the state of the PWM input.

Shoot-Through Protection

Before V_{CC} exceeding its POR level, the undervoltage protection function is activated and both GH and GL are held active low (off). When the V_{CC} voltage surpasses the Rising Threshold (see "Electrical Specifications" on [page 7](#)) the PWM, SMOD, and DE signals are used to control both high-side and low-side MOSFETs.

The rising edge on PWM initiates the turn-off of the lower MOSFET. Adaptive shoot-through circuitry monitors the GL voltage and determines a safe time for the upper MOSFET to turn on. This prevents the MOSFET's from conducting simultaneously.

The falling PWM transition causes the upper FET to turn off and the lower FET to turn-on. Adaptive shoot-through circuitry monitors the GH to SW voltage to determine a safe time for low-side MOSFET turn-on. This prevents the MOSFETs from conducting simultaneously.

If the driver has no bias voltage applied and is unable to actively hold the MOSFETs off, an integrated 20kΩ resistor from the upper MOSFET gate-to-source will aid in keeping the device in its off state. This can be especially critical in applications where the input voltage rises before the ISL99140 V_{CC} / PV_{CC} supplies.

Tri-State PWM Input

The ISL99140 supports a tri-level input on the PWM pin. If the pin is pulled into and remains in the tri-state window for a set holdoff time, the driver will force both MOSFETs to their off states. When the PWM signal moves outside the shutdown window, the driver immediately resumes driving the MOSFETs according to the PWM commands.

This feature is used by Intersil PWM controllers as a method of forcing both MOSFETs off. If the PWM input is left floating, the pin will be pulled into the tri-state window internally and force both MOSFETs to a safe off state. The ISL99140's tri-state levels are compatible with 3.3V PWM logic.

Although PWM input can sustain as high as V_{CC} , the ISL99140 is not compatible with a controller (such as ISL637x family) that actively drives its mid level in tri-state higher than 1.7V. However, the ISL99140 can be configured to be compatible with ZL8800 by connecting PWMH to PWM and PWML to EN, as shown in [Figure 4 on page 6](#). In this example, the tri-state operation is controlled by PWML output of ZL8800 through ISL99140's EN input. For detailed design information, consult the [ZL8800](#) datasheet.

Diode Emulation

Diode emulation allows for higher converter efficiency under light load situations. With diode emulation active (SMOD pulled low), the ISL99140 will detect the zero current crossing of the output inductor and turn off the low-side gate after the minimum LGATE ON time of 350ns expires. This ensures that Discontinuous Conduction Mode (DCM) is achieved to minimize losses. Diode emulation is asynchronous to the PWM signal. Therefore, the ISL99140 will respond to the SMOD input immediately after it changes state.

Bootstrap Function

The ISL99140 features an internal bootstrap Schottky diode. A high quality ceramic capacitor should be placed in close proximity across the BOOT and PHASE pins. The bootstrap capacitor can range between 0.1 μ F~0.22 μ F/0402~0603/X5R~X7R for normal buck switching applications. A resistor (typically 1.5 Ω to 3.9 Ω) in series with a bootstrap capacitor is optional, but recommended for high input voltage application to prevent exceeding the absolute maximum ratings of the device.

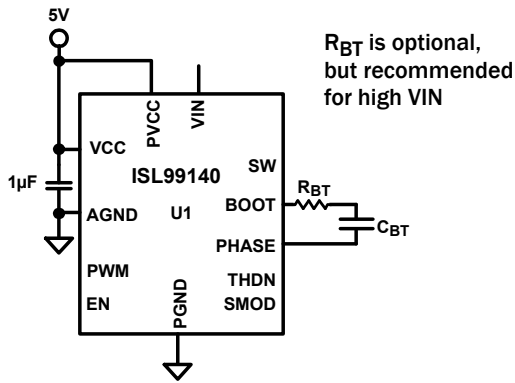

FIGURE 6. BOOT RESISTOR OPTION

Thermal Shutdown Warning (THDN)

The THDN pin is an open-drain output and is pulled low when the internal junction temperature exceeds +150 °C. The ISL99140 does not stop operation when the flag is set. This signal is often fed back to the controller to issue a system thermal shutdown. When the junction temperature drops below +135 °C, the device will clear the THDN signal.

PCB Layout Considerations

Proper PCB layout will reduce noise coupling to other circuits, improve thermal performance, and maximize the efficiency. The following is meant to lead to an optimized layout:

- Place a 0.1 μ F and multiple 10 μ F or greater ceramic capacitors directly at device between V_{IN} and PGND as indicated in [Figure 7](#). This is the most critical decoupling and reduces parasitic inductance in the power switching loop. This will reduce overall electrical stress on the device as well as reduce coupling to other circuits. Best practice is to place the decoupling capacitors on the same PCB side as the device.
- Connect PGND to the system GND plane with a large via array as close to the PGND pins as design rules allow. This improves thermal and electrical performance.
- Place PVCC, V_{CC} , and BOOT-PHASE decoupling capacitors at the IC pins with the shortest loop as shown in [Figure 7](#).
- Note that the SW plane connecting the ISL99140 and inductor must carry full load current and will create resistive loss if not sized properly. However, it is also a very noisy node that should not be oversized or routed close to any sensitive signals. Best practice is to place the inductor as close to the device as possible and thus minimize the required area for the SW connection. If the user must choose a long route of either the V_{OUT} side of the inductor or the SW side, choose the quiet V_{OUT} side. Best practice is to locate the ISL99140 as close to the final load as possible and thus avoid noisy or lossy routes to the load.

TABLE 3. AVAILABLE EVALUATION BOARDS

EVALUATION BOARDS	DESCRIPTION	SMBus/ PMBus/I ² C
ISL6388EVAL1Z	6-Phase Core VR with ISL99140, 6x6 DrMOS, and the ISL6388, EAPP Digital Controller; Socket R3	Yes
ISL6398EVAL1Z	3-Phase POL VR with ISL99140, 6x6 DrMOS, and the ISL6388, EAPP Digital Controller; On-Board Transient Load	Yes

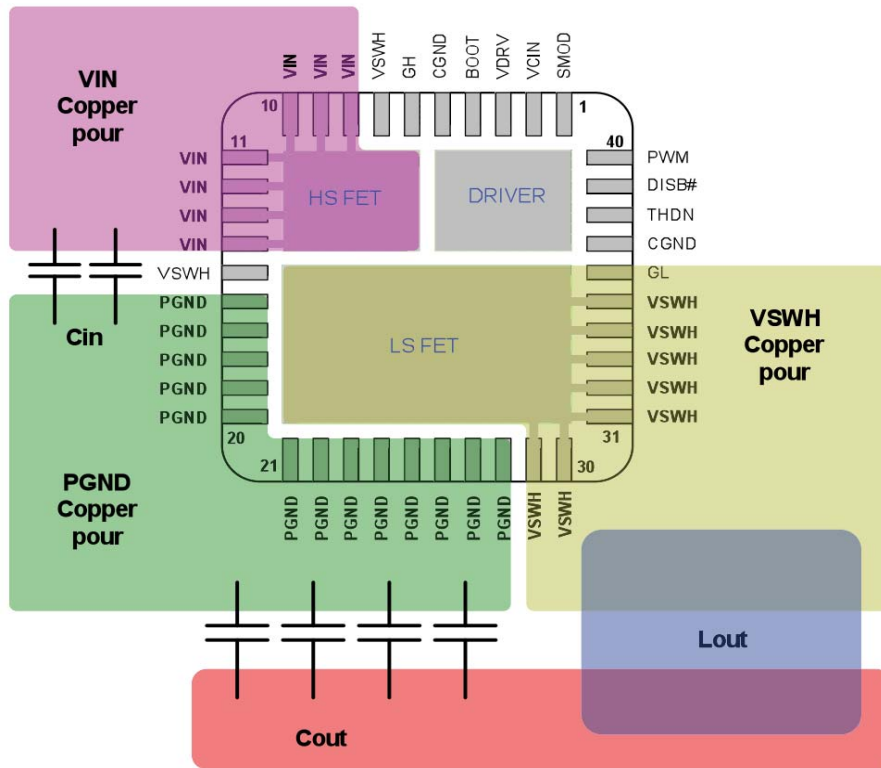

FIGURE 7. PCB LAYOUT FOR MINIMIZING CURRENT LOOPS

Typical Performance Characteristics

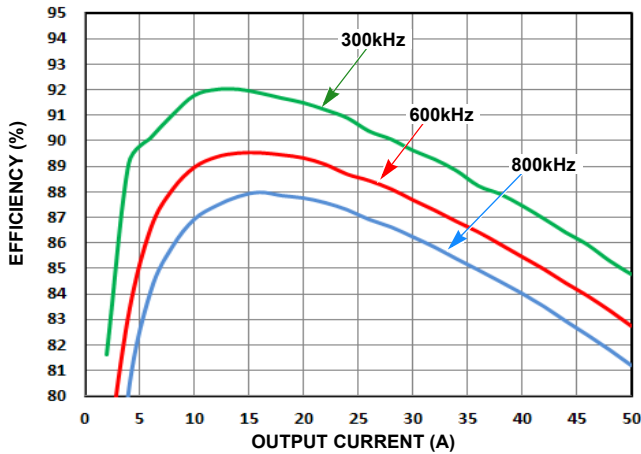

FIGURE 8. 1.0V V_{OUT} POWER STAGE EFFICIENCY
 ($V_{IN} = 12V$, $V_{CC} = P_{VCC} = 5V$; $L_{OUT} = 0.23\mu H$, $0.23m\Omega$, SLC1175-231; INCLUDE INDUCTOR AND ISL99140 LOSSES)

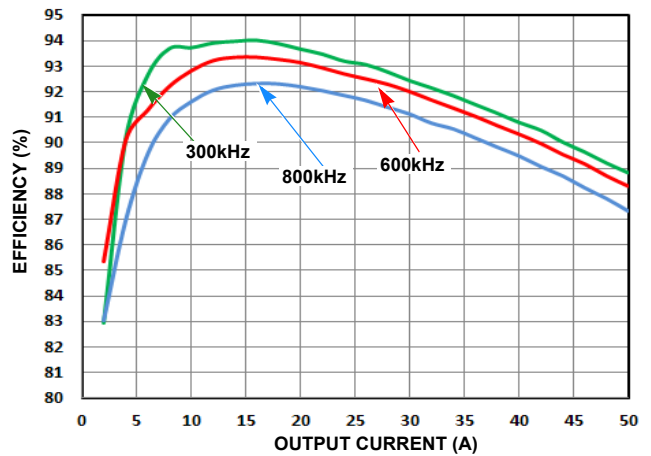

FIGURE 9. 1.8V V_{OUT} POWER STAGE EFFICIENCY
 ($V_{IN} = 12V$, $V_{CC} = P_{VCC} = 5V$; $L_{OUT} = 0.23\mu H$, $0.23m\Omega$, SLC1175-231; INCLUDE INDUCTOR AND ISL99140 LOSSES)

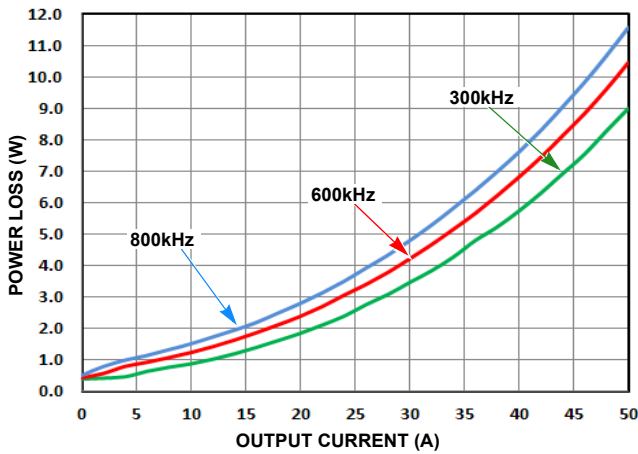

FIGURE 10. 1.0V V_{OUT} POWER STAGE DISSIPATION
 ($V_{IN} = 12V$, $V_{CC} = P_{VCC} = 5V$; $L_{OUT} = 0.23\mu H$, $0.23m\Omega$, SLC1175-231; INCLUDE INDUCTOR AND ISL99140 LOSS)

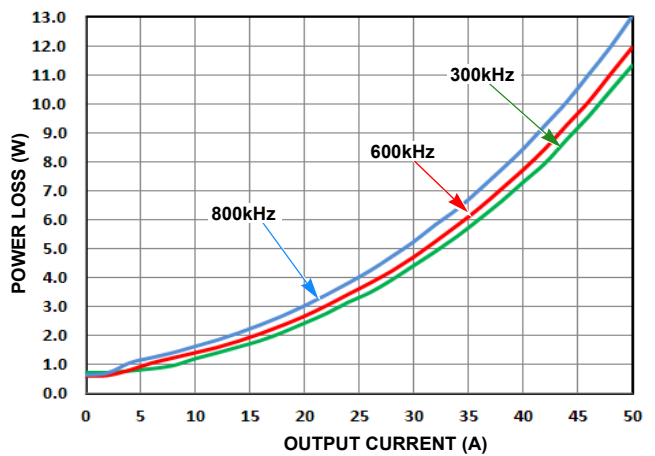

FIGURE 11. 1.8V V_{OUT} POWER STAGE DISSIPATION
 ($V_{IN} = 12V$, $V_{CC} = P_{VCC} = 5V$; $L_{OUT} = 0.23\mu H$, $0.23m\Omega$, SLC1175-231; INCLUDE INDUCTOR AND ISL99140 LOSSES)

Revision History

The revision history provided is for informational purposes only and is believed to be accurate, but not warranted. Please visit our website to make sure that you have the latest revision.

DATE	REVISION	CHANGE
Jul 20, 2017	FN8642.2	Updated Related Literature section. Added Table 1. Updated the BOOT and VIN pin descriptions. Added 40A continuous current under absolute maximum ratings. Updated Theta JA value from "50" to "14.5". Updated Note 4. Added Notes 7, 8, and 9. Opened up the recommended VIN range from "4.5V to 18V" to "0 to 20V". In "Power-On Reset (POR) and EN" on page 9, changed "3.5V" to "3.4V" and "2.95V" to "2.92V" to match page 7 in the "Electrical Specifications" table. Updated Note 12, corrected typo LG to GL. Updated "Bootstrap Function" on page 10. Added "a 0.1µF and" on first bullet and "the with shortest loop" on the third bullet under PCB Layout Considerations.
Jan 7, 2016	FN8642.1	Updated the Ordering Information table on page 2 by adding the tape and reel quantity. Under "Absolute Maximum Ratings" on page 7, added the following: "Phase Voltage.....(GND - 0.3V) to 30V (GND-10V) (<20ns Pulse Width, 10µJ)
May 5, 2014	FN8642.0	Initial release

About Intersil

Intersil Corporation is a leading provider of innovative power management and precision analog solutions. The company's products address some of the largest markets within the industrial and infrastructure, mobile computing, and high-end consumer markets.

For the most updated datasheet, application notes, related documentation, and related parts, see the respective product information page found at www.intersil.com.

For a listing of definitions and abbreviations of common terms used in our documents, visit www.intersil.com/glossary.

You can report errors or suggestions for improving this datasheet by visiting www.intersil.com/ask.

Reliability reports are also available from our website at www.intersil.com/support.

© Copyright Intersil Americas LLC 2014-2017. All Rights Reserved.
All trademarks and registered trademarks are the property of their respective owners.

For additional products, see www.intersil.com/en/products.html

Intersil products are manufactured, assembled and tested utilizing ISO9001 quality systems as noted in the quality certifications found at www.intersil.com/en/support/qualandreliability.html

Intersil products are sold by description only. Intersil may modify the circuit design and/or specifications of products at any time without notice, provided that such modification does not, in Intersil's sole judgment, affect the form, fit or function of the product. Accordingly, the reader is cautioned to verify that datasheets are current before placing orders. Information furnished by Intersil is believed to be accurate and reliable. However, no responsibility is assumed by Intersil or its subsidiaries for its use; nor for any infringements of patents or other rights of third parties which may result from its use. No license is granted by implication or otherwise under any patent or patent rights of Intersil or its subsidiaries.

For information regarding Intersil Corporation and its products, see www.intersil.com

Package Outline Drawing

L40.6x6A

40 LEAD THIN QUAD FLAT NO-LEAD PLASTIC PACKAGE

Rev 0, 3/14

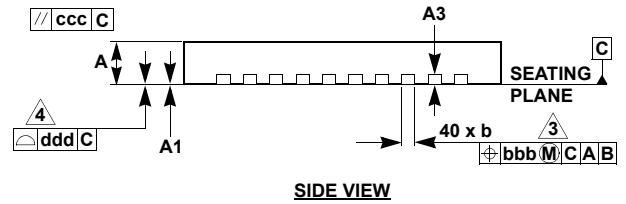
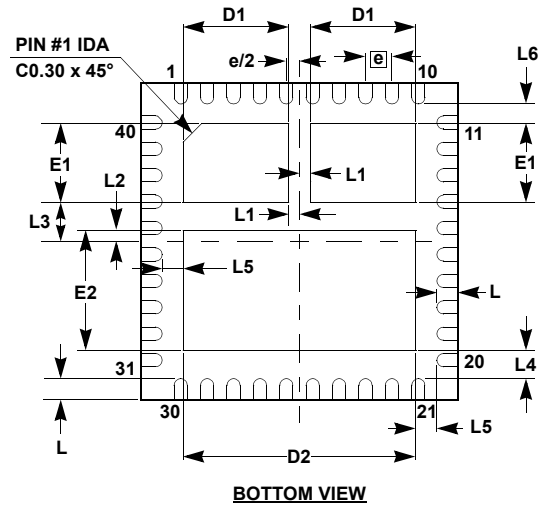
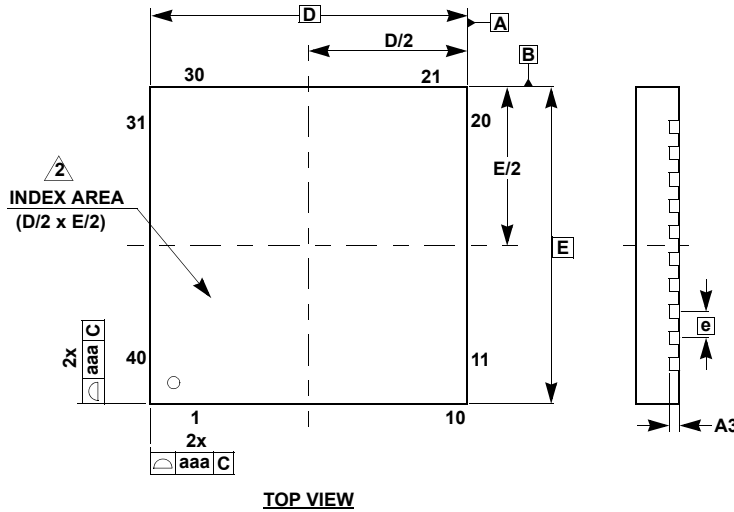

DIMENSIONS IN MILLIMETERS

SYMBOLS	MIN	TYP	MAX
A	0.70	0.75	0.80
A1	0.00	0.02	0.05
A3	0.20 REF		
b	0.20	0.25	0.35
D	6.00 BSC		
D1	1.90	2.00	2.10
D2	4.30	4.40	4.50
E	6.00 BSC		
E1	1.40	1.50	1.60
E2	2.17	2.27	2.37
e	0.50 BSC		
L	0.30	0.40	0.50
L1	0.15	0.20	0.25
L2	0.15	0.21	0.26
L3	0.63	0.73	0.83
L4	0.44	0.54	0.64
L5	0.30	0.40	0.50
L6	0.27	0.37	0.47
aaa	0.15		
bbb	0.10		
ccc	0.10		
ddd	0.08		

NOTES:

- Dimensions are in millimeters.
- The location of the terminal #1 identifier and terminal numbering convention conforms to JEDEC publication 95 SPP-002.
- Dimension b applies to metallized terminal and is measured between 0.20mm and 0.35mm from the terminal tip. If the terminal has the optional radius on the other end of the terminal, the dimension b should not be measured in that radius area.
- Coplanarity applies to the terminals and all other bottom surface metallization.

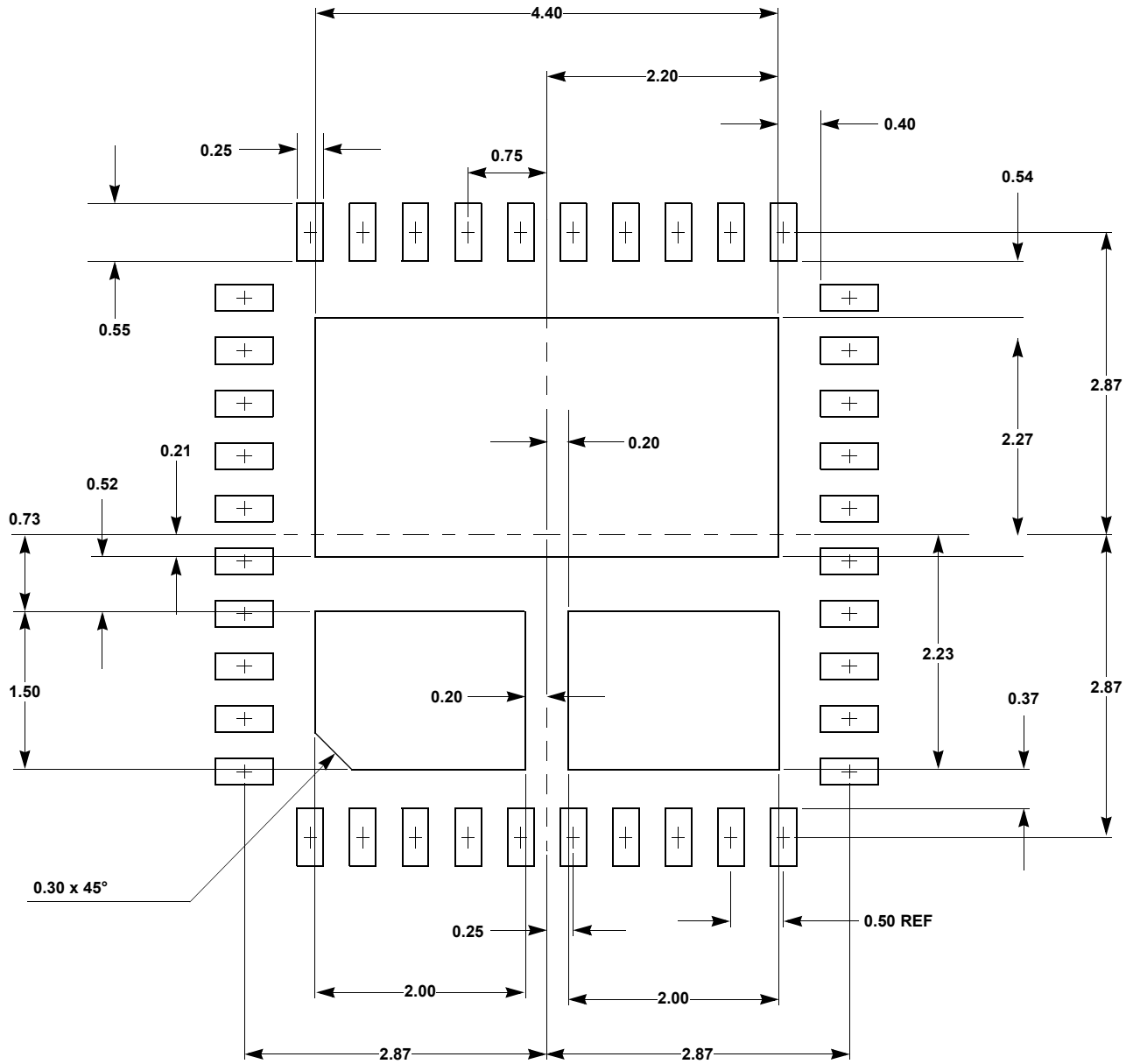

RECOMMENDED LAND PATTERN

NOTE:

1. Dimensions are in millimeters.

Looking for pricing, stock, or lifecycle information?

Click below to explore more details on WIN SOURCE:

 [View ISL99140IRZ-T on WIN SOURCE](#)

 [Intersil Information](#)

Optimize Your Supply Chain with WIN SOURCE Solutions

-  Global Sourcing Solution
-  Obsolete Management
-  Cost Control Management
-  Shortage Management
-  Alternative Solution
-  Excess Inventory Management