



**THE DATASHEET OF**  
**AL8811M8-13**



## Description

The AL8811 is a monolithic control circuit containing the primary functions required for DC-to-DC converters. These devices consist of an internal temperature compensated reference, comparator, controlled duty cycle oscillator with an active current limit circuit, driver and high current output switch. This series is specifically designed for incorporating in Boost, Buck and voltage-inverting applications with a minimum number of external components.

## Features

- Operation from 3.0V to 20V Input
- Low Standby Current
- Current Limiting
- Output Switch Current to 1.6A
- Output Voltage Adjustable
- Frequency Operation to 100 kHz
- Precision 2% Reference
- **Totally Lead-Free & Fully RoHS Compliant (Notes 1 & 2)**
- **Halogen and Antimony Free. "Green" Device (Note 3)**

Notes: 1. No purposely added lead. Fully EU Directive 2002/95/EC (RoHS) & 2011/65/EU (RoHS 2) compliant.  
2. See [http://www.diodes.com/quality/lead\\_free.html](http://www.diodes.com/quality/lead_free.html) for more information about Diodes Incorporated's definitions of Halogen- and Antimony-free, "Green" and Lead-free.  
3. Halogen- and Antimony-free "Green" products are defined as those which contain <900ppm bromine, <900ppm chlorine (<1500ppm total Br + Cl) and <1000ppm antimony compounds.

## Pin Assignments

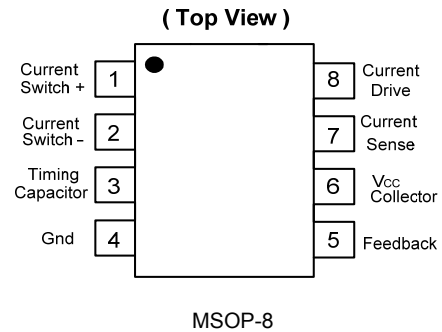

## Applications

- Low Voltage LED Lighting such as MR-16
- General Purpose DC-DC Converter

## Typical Application Diagram

Electronic Transformer compatible MR16 lamp Simplified Schematic

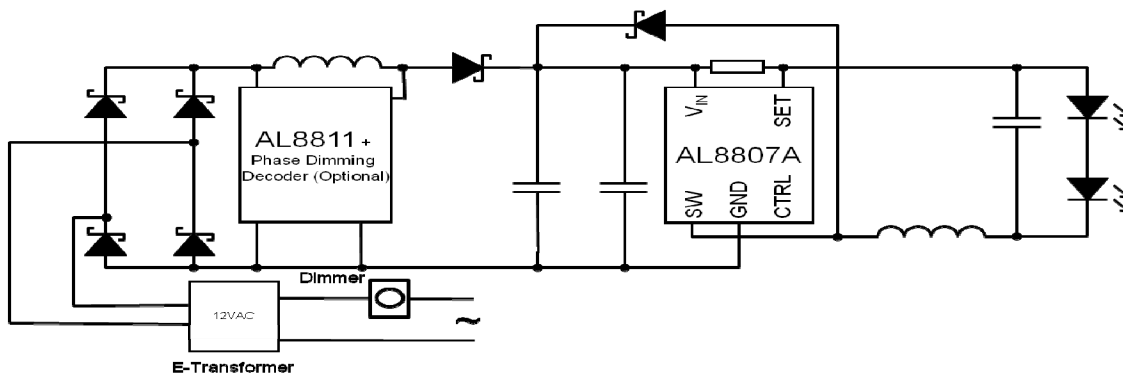

**Pin Descriptions**

Pin Name	Pin Number	Descriptions
Current Switch+	1	Internal switch transistor collector: Connect to Inductor for boost converter. Connect to $V_{CC}$ for Buck or Inverting converter
Current Switch-	2	Internal switch transistor emitter: Connect to GND for boost converter Connect to Inductor for buck or inverting converter
CT	3	Timing Capacitor to control the switching frequency
GND	4	
Feedback	5	Feedback pin for inverting input of internal comparator
VCC	6	Supply voltage pin
Current Sense	7	Peak Current Sense Input by monitoring the voltage drop across an external current sense resistor to limit the peak current through the switch
Current Drive	8	Current drive collector: Normally connected to $V_{CC}$ directly or via a resistor.

**Functional Diagram**

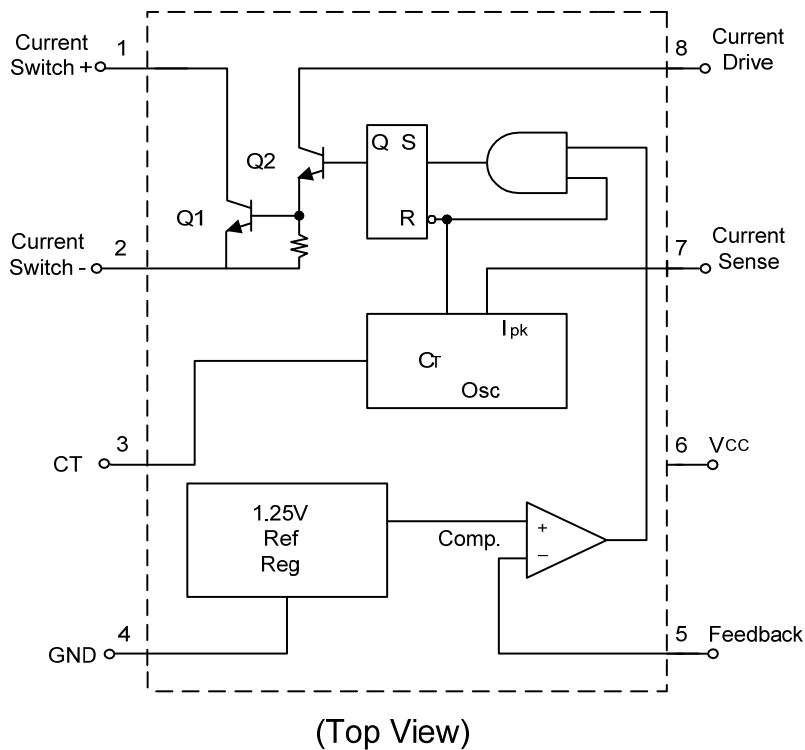

**Absolute Maximum Ratings** (@ $T_A = +25^\circ\text{C}$ , unless otherwise specified.)

Symbol	Parameter	Rating	Unit
$V_{CC}$	Power Supply Voltage	20	V
$V_{IR}$	Comparator Input Voltage Range	-0.3 to +36	V
$V_{C(SWITCH)}$	"Current Switch +" Collector Voltage	36	V
$V_{E(SWITCH)}$	„Current Switch –„ Emitter Voltage ( $V_{PIN\ 1} = 36\text{V}$ )	36	V
$V_{CE(SWITCH)}$	"Current Switch" Collector to Emitter Voltage	36	V
$V_{C(DRIVER)}$	"Current Drive" Collector Voltage	36	V
$I_{C(DRIVER)}$	"Current Drive" Collector Current	100	mA
$I_{SW}$	"Current Switch" Current	1.6	A
$P_D$	Power Dissipation (Note 4)	600	mW
$\theta_{JA}$	Thermal Resistance	130	$^\circ\text{C/W}$
$T_{MJ}$	Maximum Junction Temperature	+150	$^\circ\text{C}$
$T_{STG}$	Storage Temperature Range	-65 to +150	$^\circ\text{C}$
ESD HBM	Human Body Model ESD Protection	1	kV
ESD MM	Machine Model ESD Protection	150	V

Caution: Stresses greater than the 'Absolute Maximum Ratings' specified above, may cause permanent damage to the device. These are stress ratings only; functional operation of the device at these or any other conditions exceeding those indicated in this specification is not implied. Device reliability may be affected by exposure to absolute maximum rating conditions for extended periods of time.

Semiconductor devices are ESD sensitive and may be damaged by exposure to ESD events. Suitable ESD precautions should be taken when handling and transporting these devices.

**Recommended Operating Conditions**

Symbol	Parameter	Min	Max	Unit
$V_{CC}$	Supply Voltage	3	20	V
$T_{OP}$	Operating Junction Temperature Range	-40	+105	$^\circ\text{C}$

**Electrical Characteristics** (@  $V_{CC} = 5\text{V}$ ,  $T_A = +25^\circ\text{C}$ , unless otherwise specified.)

Symbol	Parameter	Min	Typ	Max	Unit
<b>OSCILLATOR</b>					
$f_{OSC}$	Frequency ( $V_{PIN\ 5} = 0\text{V}$ , $C_T = 1.0\text{nF}$ , $T_A = +25^\circ\text{C}$ )	24	33	42	kHz
$I_{CHG}$	Charge Current ( $V_{CC} = 5.0\text{V}$ to $20\text{V}$ , $T_A = +25^\circ\text{C}$ )	24	30	42	$\mu\text{A}$
$I_{DISCHG}$	Discharge Current ( $V_{CC} = 5.0\text{V}$ to $20\text{V}$ , $T_A = +25^\circ\text{C}$ )	140	200	260	$\mu\text{A}$
$I_{DISCHG}/I_{CHG}$	Discharge to Charge Current Ratio (Pin 7 to $V_{CC}$ , $T_A = +25^\circ\text{C}$ )	5.2	6.5	7.5	—
$V_{IPK(SENSE)}$	Current Limit Sense Voltage ( $I_{CHG} = I_{DISCHG}$ , $T_A = +25^\circ\text{C}$ )	300	400	450	mV
<b>OUTPUT SWITCH (Note 4)</b>					
$V_{CE(sat)}$	Saturation Voltage, Darlington Connection ( $I_{SW} = 1.0\text{A}$ , Pins 1, 8 connected)	—	1.0	1.3	V
$V_{CE(sat)}$	Saturation Voltage, Darlington Connection ( $I_{SW} = 1.0\text{A}$ , $I_D = 50\text{mA}$ , Forced $\beta \approx 20$ )	—	0.45	0.7	V
$h_{FE}$	DC Current Gain ( $I_{SW} = 1.0\text{A}$ , $V_{CE} = 5.0\text{V}$ , $T_A = +25^\circ\text{C}$ )	50	75	—	—
$I_{C(off)}$	Collector Off-State Current ( $V_{CE} = 20\text{V}$ )	—	0.01	100	$\mu\text{A}$
<b>COMPARATOR</b>					
$V_{th}$	Threshold Voltage $T_A = +25^\circ\text{C}$	1.225	1.25	1.275	V
$Reg_{(LINE)}$	Threshold Voltage Line Regulation ( $V_{CC} = 3.0\text{V}$ to $20\text{V}$ )	—	1.4	6.0	mV
<b>TOTAL DEVICE</b>					
$I_{CC}$	Supply Current ( $V_{CC} = 5.0\text{V}$ to $20\text{V}$ , $C_T = 1.0\text{nF}$ , Pin 7 = $V_{CC}$ , $V_{PIN\ 5} > V_{th}$ Pin 2 = Gnd, remaining pins open)	—	—	3.5	mA

**Typical Performance Characteristics**

**Figure 1. Vce(sat) versus Ie**

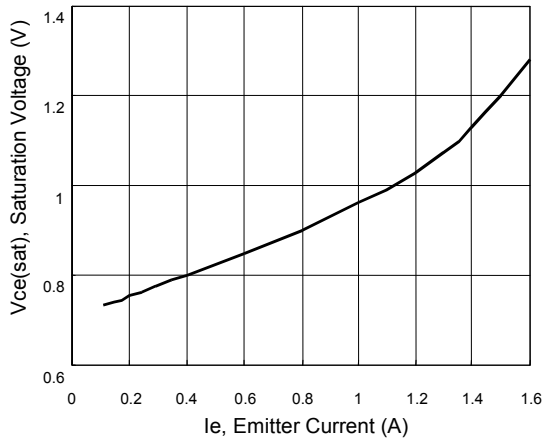

**Figure 2. Reference Voltage versus Temp.**

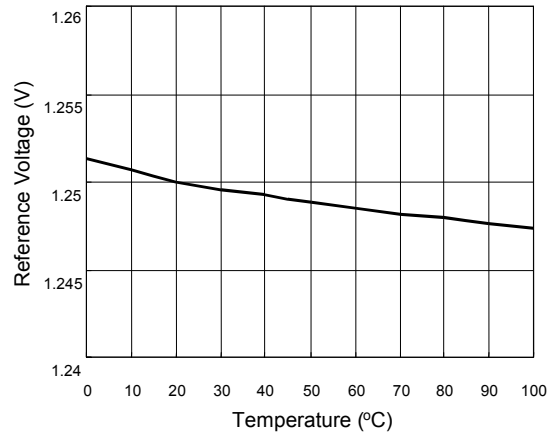

**Figure 3. Current Limit Sense Voltage versus Temperature**

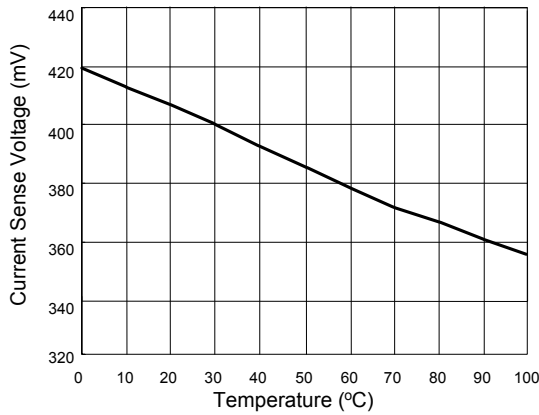

**Figure 4. Standby Supply Current versus Supply Voltage**

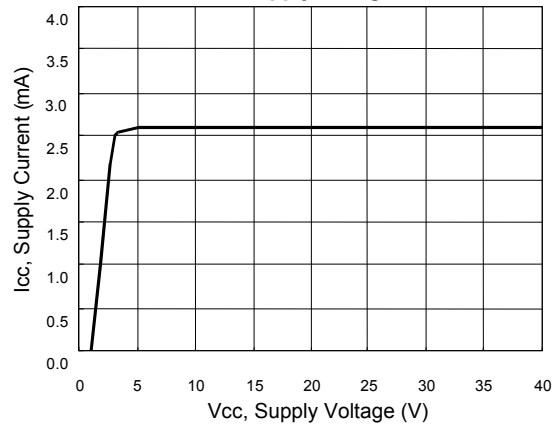

**Figure 5. Emitter Follower Configuration Output Saturation Voltage vs. Emitter Current**

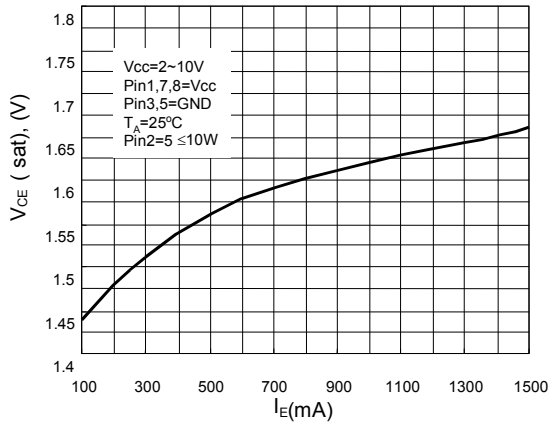

**Figure 6. Output Switch On-Off Time versus Oscillator Timing Capacitor**

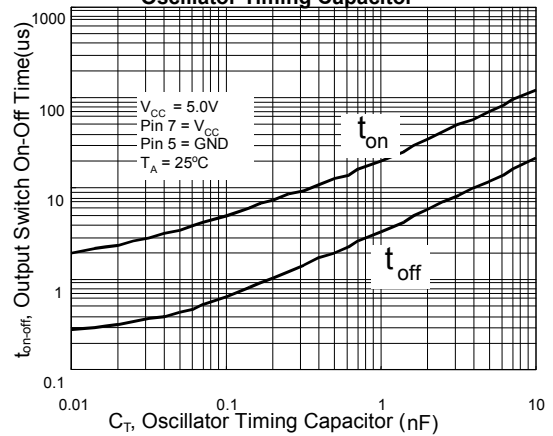

## Application Circuit

### (1) Boost Converter

Test	Conditions	Results
Line Regulation	$V_{IN} = 9V$ to $12V$ , $I_O = 200mA$	$20mV = \pm 0.035\%$
Load Regulation	$V_{IN} = 12V$ , $I_O = 50mA$ to $200mA$	$15mV = \pm 0.035\%$
Output Ripple	$V_{IN} = 12V$ , $I_O = 200mA$	$500mV_{PP}$
Efficiency	$V_{IN} = 12V$ , $I_O = 200mA$	80%

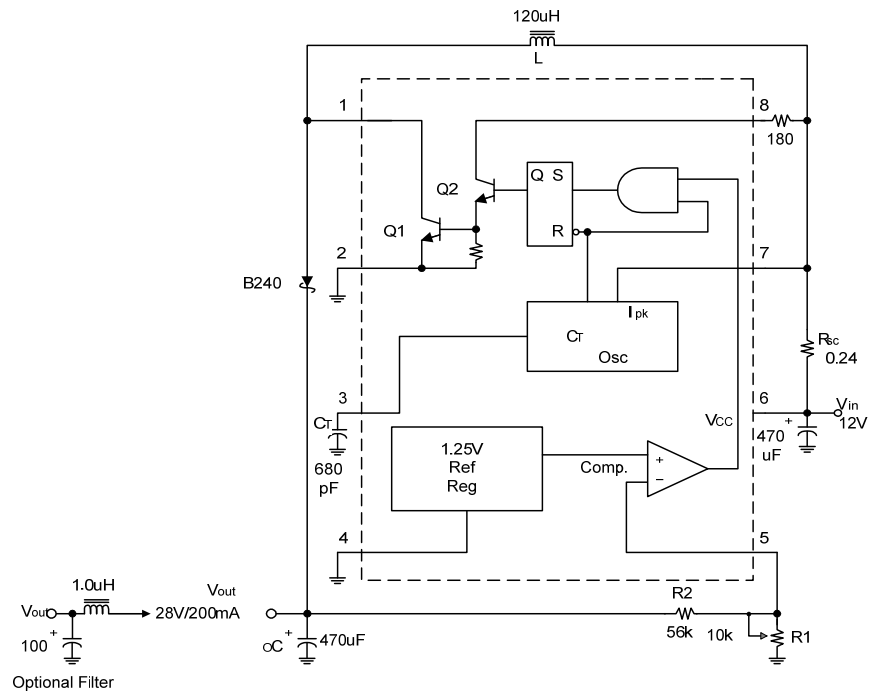

**Application Circuit (cont.)**

**(2) Electronic Transformer compatible triac dimmable MR16/GU5.3 lamp for 120Vac**

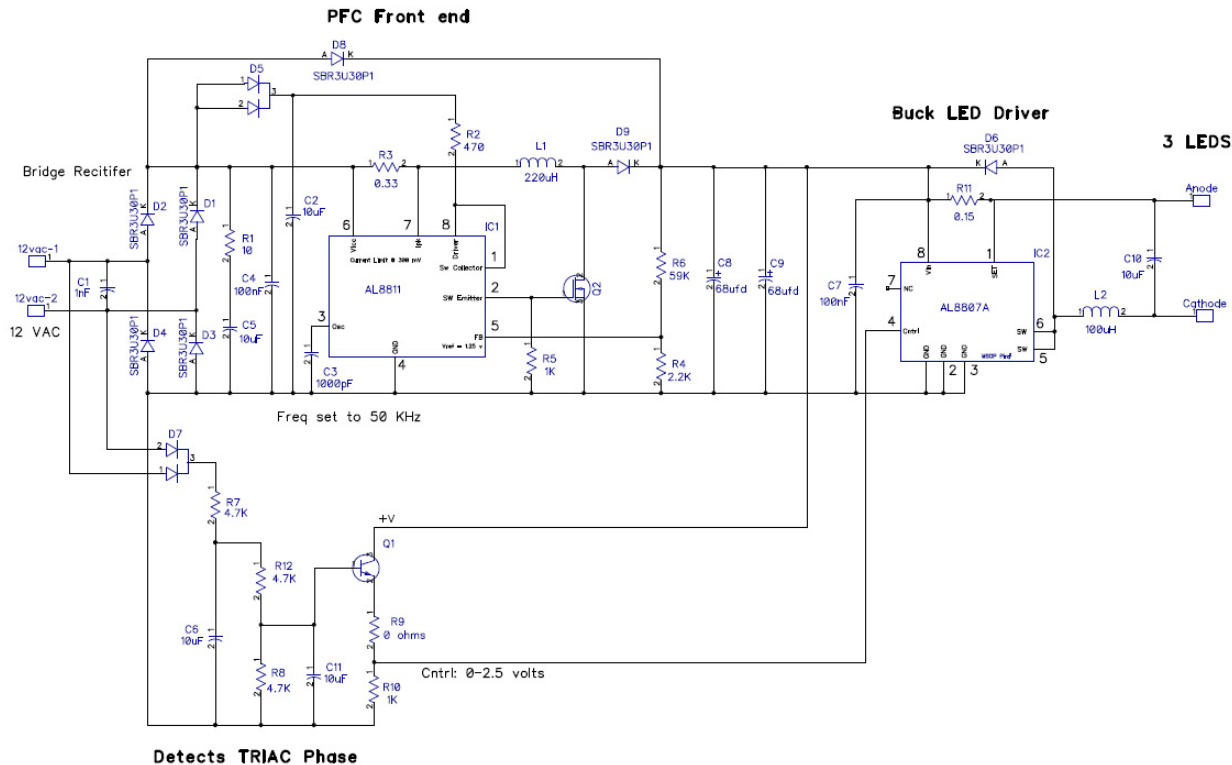

**Detects TRIAC Phase**

**Circuit Description**

This design consists of three sections:

- 1) The input PFC circuit converts the 12V<sub>AC</sub> input voltage to a DC voltage around 30V (AL8811).
- 2) The output Buck LED Driver drives the three LEDs in series at a fixed current (AL8807A).
- 3) Finally, the phase-detect circuit generates a voltage proportional to the phase of the incoming AC voltage (when triac dimming is used).

**PFC Circuit**

The AL8811 Boost converter is a simple “Constant ON time controller”. By keeping the same ON time throughout the AC cycle, the circuit will draw a current that will closely match the voltage and result in a constant input current. This eliminates the classic peak current problem with a bridge rectifier and a large input filter capacitor.

The PFC circuit includes the input bridge rectifier, EMI filter (if needed) and the AL8811 Boost converter. The AC input voltage is rectified by the bridge circuit and filtered by C1, R1, C4, and C5. This first filter removes the high frequency that is generated by the Electronic Transformer in the range of 20-30 KHz. An additional diode rectifier circuit (D5, C2) is used to generate a voltage that is used to power the circuit that will turn on/off the external MOSFET of the Boost converter. This circuit is very important as the gate drive of the MOSFET has to be greater than 3-4 volts throughout the AC cycle. The external MOSFET is used to reduce the heat dissipation in the AL8811.

The AL8811 has a current limit resistor R3 which sets the maximum current allowed through the inductor L1. The output voltage is set by the divider R6, R5 to an output of around 35 volts. The output voltage is filtered by the two capacitors C8 and C9. These two capacitors store energy that will be used when the input voltage is low during the AC cycle.

---

## Application Circuit (cont.)

---

### Buck LED Driver

The AL8807A is a step-down DC-DC converter designed to drive LEDs with a constant current. The current through the LED is controlled by R11. In the present Evaluation board, the current is set to around 660mA based on a resistor value of 0.15Ω. The current is set using the "CTRL" input pin which in this new version of the IC can vary from 0 to 2.5V, controlling the current from 0mA to the maximum current at 2.5V. This control input pin is used to lower the LED current as the TRIAC dims the LED. In this way, the energy stored in the two output capacitors of the PFC circuit will be able to provide current throughout the AC cycle.

### TRIAC Phase Detection Circuit

The phase of the TRIAC is detected by using an additional rectifier circuit that generates a voltage in proportional to the phase of the TRIAC Driver. This is done by rectifying the input AC voltage and averaging the energy using a resistor to charge a capacitor. Two additional resistors in series, R12 and R8, slowly discharge this circuit so it will follow the input phase change. The two resistors, R12 and R8, are used to scale the voltage so the range is from 0 to 2.6V to the Buck LED driver control pin.

A simple transistor emitter follower circuit is used to drive a 1KΩ resistor in the emitter circuit. This low resistance is needed to drive the input control pin of the AL8807A LED driver because the pin outputs a small current of 50uA, which limits the lowest control voltage to around 50 mV.

### Setting the LED output current (AL8807A):

The LED output current is set using resistor R11 and the formula:

$$I_{LED} = V_{TH} / R11 \quad \text{where } V_{TH} \text{ is equal to } 0.1V$$

For a current of 660mA, R11 is about 0.15Ω.

### Setting the PFC Variables (AL8811)

The choice for the size of the boost converter inductor selected in this design is based on a compromise which it is able to support a peak current to around 1.5A since the average input voltage will be around 12-14V.

The boost converter (AL8811) includes a current limit resistor R3 which will limit the current through the inductor and thus the power delivered to the output load. The formula for the resistor is:

$$I_{PK(switch)} = 0.33V / R3$$

For a current limit of 1A, R3 is 0.33Ω.

In this evaluation design, this value was selected based on having three LEDs in series drawing about 660mA. It was found that two 68μF capacitors mounted in parallel would just fit into the cavity of the MR16 bulb. The important design goal is to have the PFC circuit, which is used to always draw current from the Electronic Transformer.

**Application Circuit** (cont.)

(3) **Buck Converter**

Test	Conditions	Results
Line Regulation	$V_{IN} = 12V$ to $20V$ , $I_O = 500mA$	$20mV = \pm 0.2\%$
Load Regulation	$V_{IN} = 20V$ , $I_O = 50mA$ to $500mA$	$5mV = \pm 0.05\%$
Output Ripple	$V_{IN} = 20V$ , $I_O = 500mA$	$160mV_{PP}$
Efficiency	$V_{IN} = 20V$ , $I_O = 500mA$	$82\%$

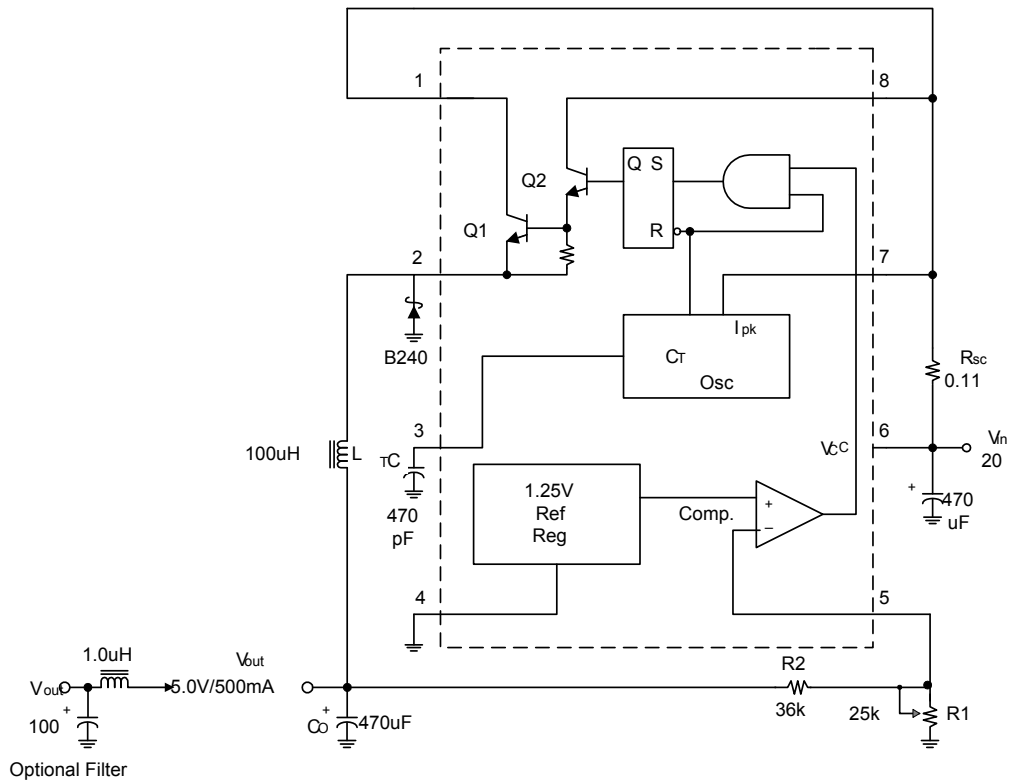

**Application Circuit** (cont.)

(4) **Voltage Inverting Converter**

Test	Conditions	Results
Line Regulation	$V_{in} = 4.5V$ to $6.0V$ , $I_O = 100mA$	$20mV = \pm 0.08\%$
Load Regulation	$V_{in} = 5.0V$ , $I_O = 20mA$ to $100mA$	$30mV = \pm 0.12\%$
Output Ripple	$V_{in} = 5.0V$ , $I_O = 100mA$	$500mV_{PP}$
Efficiency	$V_{in} = 5.0V$ , $I_O = 100mA$	60%

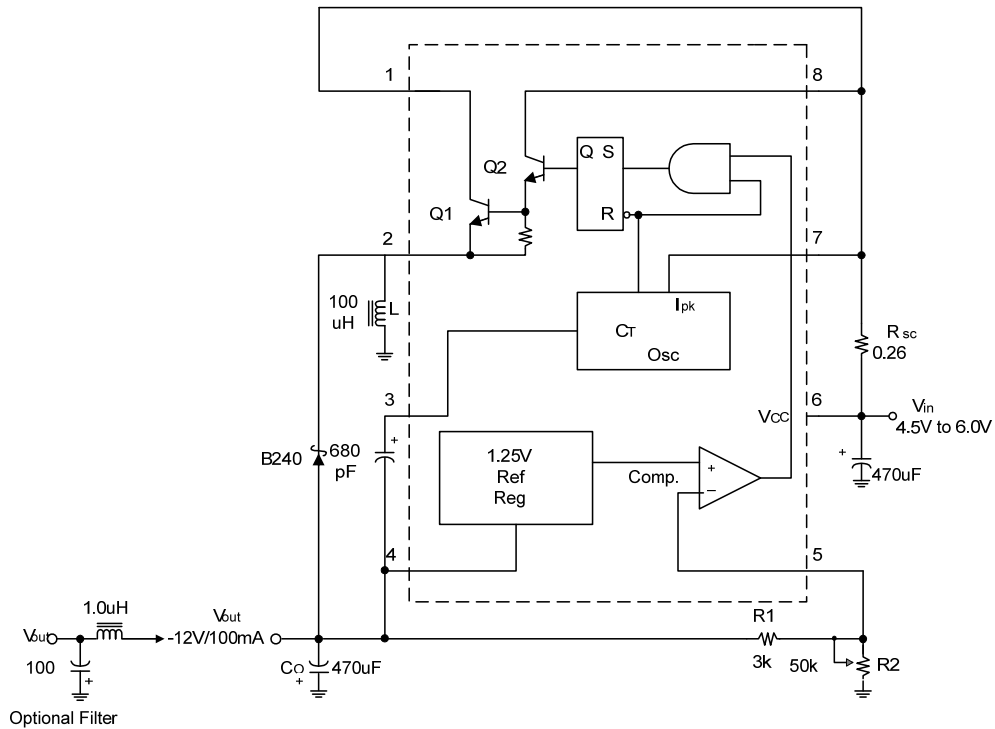

## Ordering Information

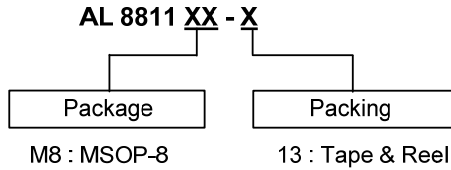

Part Number	Package Code	Packaging	Tube		13" Tape and Reel	
			Quantity	Part Number Suffix	Quantity	Part Number Suffix
AL8811M8-13	M8	MSOP-8	NA	NA	2500/Tape & Reel	-13

## Marking Information

(1) MSOP-8

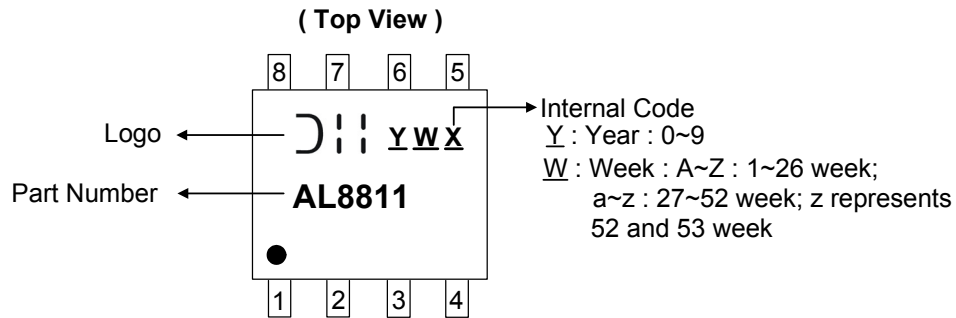

## Package Outline Dimensions (All dimensions in mm.)

Please see AP02002 at <http://www.diodes.com/datasheets/ap02002.pdf> for latest version.

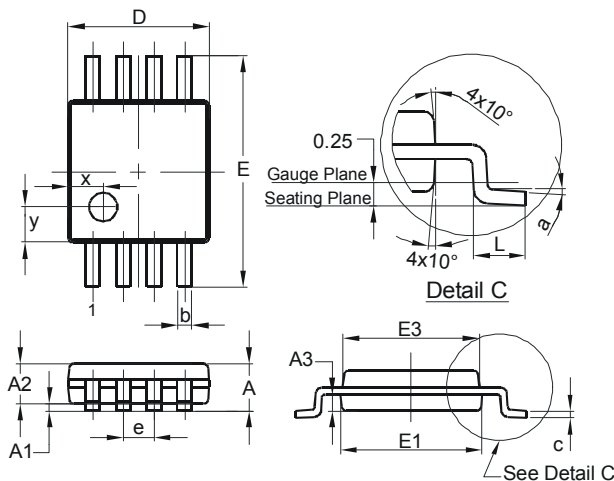

MSOP-8			
Dim	Min	Max	Typ
A	-	1.10	-
A1	0.05	0.15	0.10
A2	0.75	0.95	0.86
A3	0.29	0.49	0.39
b	0.22	0.38	0.30
c	0.08	0.23	0.15
D	2.90	3.10	3.00
E	4.70	5.10	4.90
E1	2.90	3.10	3.00
E3	2.85	3.05	2.95
e	-	-	0.65
L	0.40	0.80	0.60
a	0°	8°	4°
x	-	-	0.750
y	-	-	0.750
<b>All Dimensions in mm</b>			

## Suggested Pad Layout

Please see AP02001 at <http://www.diodes.com/datasheets/ap02001.pdf> for the latest version.

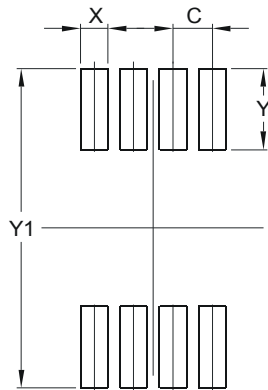

Dimensions	Value (in mm)
C	0.650
X	0.450
Y	1.350
Y1	5.300

### IMPORTANT NOTICE

DIODES INCORPORATED MAKES NO WARRANTY OF ANY KIND, EXPRESS OR IMPLIED, WITH REGARDS TO THIS DOCUMENT, INCLUDING, BUT NOT LIMITED TO, THE IMPLIED WARRANTIES OF MERCHANTABILITY AND FITNESS FOR A PARTICULAR PURPOSE (AND THEIR EQUIVALENTS UNDER THE LAWS OF ANY JURISDICTION).

Diodes Incorporated and its subsidiaries reserve the right to make modifications, enhancements, improvements, corrections or other changes without further notice to this document and any product described herein. Diodes Incorporated does not assume any liability arising out of the application or use of this document or any product described herein; neither does Diodes Incorporated convey any license under its patent or trademark rights, nor the rights of others. Any Customer or user of this document or products described herein in such applications shall assume all risks of such use and will agree to hold Diodes Incorporated and all the companies whose products are represented on Diodes Incorporated website, harmless against all damages.

Diodes Incorporated does not warrant or accept any liability whatsoever in respect of any products purchased through unauthorized sales channel. Should Customers purchase or use Diodes Incorporated products for any unintended or unauthorized application, Customers shall indemnify and hold Diodes Incorporated and its representatives harmless against all claims, damages, expenses, and attorney fees arising out of, directly or indirectly, any claim of personal injury or death associated with such unintended or unauthorized application.

Products described herein may be covered by one or more United States, international or foreign patents pending. Product names and markings noted herein may also be covered by one or more United States, international or foreign trademarks.

This document is written in English but may be translated into multiple languages for reference. Only the English version of this document is the final and determinative format released by Diodes Incorporated.

### LIFE SUPPORT

Diodes Incorporated products are specifically not authorized for use as critical components in life support devices or systems without the express written approval of the Chief Executive Officer of Diodes Incorporated. As used herein:

A. Life support devices or systems are devices or systems which:

1. are intended to implant into the body, or
2. support or sustain life and whose failure to perform when properly used in accordance with instructions for use provided in the labeling can be reasonably expected to result in significant injury to the user.

B. A critical component is any component in a life support device or system whose failure to perform can be reasonably expected to cause the failure of the life support device or to affect its safety or effectiveness.

Customers represent that they have all necessary expertise in the safety and regulatory ramifications of their life support devices or systems, and acknowledge and agree that they are solely responsible for all legal, regulatory and safety-related requirements concerning their products and any use of Diodes Incorporated products in such safety-critical, life support devices or systems, notwithstanding any devices- or systems-related information or support that may be provided by Diodes Incorporated. Further, Customers must fully indemnify Diodes Incorporated and its representatives against any damages arising out of the use of Diodes Incorporated products in such safety-critical, life support devices or systems.

Copyright © 2013, Diodes Incorporated

[www.diodes.com](http://www.diodes.com)

## Looking for pricing, stock, or lifecycle information?

Click below to explore more details on WIN SOURCE:

- ⊖ [View AL8811M8-13 on WIN SOURCE](#)
- ⊖ [Diodes Incorporated Information](#)

## Optimize Your Supply Chain with WIN SOURCE Solutions

- ✓ Global Sourcing Solution
- ✓ Obsolete Management
- ✓ Cost Control Management
- ✓ Shortage Management
- ✓ Alternative Solution
- ✓ Excess Inventory Management