



# THE DATASHEET OF PTN5100DBSMP



# PTN5100D

## USB Type-C power delivery PHY and protocol IC

Rev. 1 — 2 August 2016

Product data sheet

## 1. General description

---

PTN5100D is a single port USB Type-C Power Delivery (PD) PHY and Protocol IC that provides Type-C Configuration channel interface and USB PD Physical and Protocol layer functions to a System PD Port Policy Controller (Policy Engine and Device Policy Manager, Alternate mode controller). It complies with USB PD[1] and Type-C[2] specifications. PTN5100D is architected to deliver robust performance, compliant behavior, configurability and system implementation flexibility that are essential to tide over interoperability and compliance hurdles in the platform applications.

PTN5100D can support system realization of the following PD roles: (i) Consumer only (ii) Consumer/Provider. Further, it is register programmed to operate in Type-C specific Upstream Facing Port (UFP). It can work along with the PD policy controller to operate in other modes (DFP, DRP).

PTN5100D operates from platform power supply VDD, or it can also be powered from USB power VBUS directly. The host interface operates on VIO supply to facilitate interfacing to systems that use IO supply rail different from VDD supply rail.

It provides SPI/I2C interface for system host control/status update. The interface choice is pre-configured in NXP factory.

PTN5100D is available in a small footprint package option: HVQFN20 4 mm x 4 mm, 0.5 mm pitch.

## 2. Features and benefits

---

### 2.1 USB PD and Type-C Features

Complies with USB PD[1] and USB Type-C[2] specifications.

- Supports implementation of various system PD roles: Consumer, Consumer/Provider
- Supports Type-C role configurability
  - ◆ Type-C role (UFP, DFP)
  - ◆ Implements UFP role pull down behavior to handle dead battery condition on battery powered platforms
  - ◆ Implements 'Rd' indication on CC pin
- Cooperatively works under the control of Policy controller MCU for power delivery negotiation and contract(s), Alternate mode and VDM exchanges
  - ◆ Implements BMC (de)coding, 4B5B symbol (de)coding, CRC generation/checking, PD packet assembling/disassembling including Preamble, SOP, EOP, Good CRC response, Retries, Hard and Cable resets
  - ◆ PD PHY and Protocol layer interface control and status update handled via SPI/I2C interface



- DRP and DFP roles can be supported

## 2.2 System protection features

- Back current protection on all pins when PTN5100D is unpowered
- CC1 and CC2 pins are 5.5 V tolerant
- VBUS pin and VBUS power path MOSFET enable pins are 28 V tolerant

## 2.3 General

- Delivers (active LOW enable) gate control signals for PMOS Power MOSFETs on VBUS source and sink power paths
- Provides dedicated IO pin (CC\_ORIENT) for indicating Cable/plug orientation
- Delivers up to 30 mA (max) for powering Policy controller MCU
- Supports SPI slave interface (SPI modes 1 and 2 supported) up to 30 MHz
- Supports I2C slave interface standard mode (100 kHz), Fast mode (400 kHz) and Fast mode plus (1 MHz)
- I2C Device slave address programmable up to 3 values
- Supports 3.3 V or 1.8 V capable I<sup>2</sup>C-bus or SPI interface
  - ◆ Supports register access - device configuration, control and status/interrupt interfacing through Slave I<sup>2</sup>C-bus interface
- Power supplies - VDD (3.3 V ±10 %) or VBUS
  - ◆ Tolerant up to 28 V on VBUS and operational up to maximum of 25 V on VBUS
- Operating temperature -20 °C to 85 °C
- ESD 8 kV HBM, 1 kV CDM
- Package: HVQFN20 4 mm × 4 mm, 0.5 mm pitch.

## 3. Applications

- PC accessories/peripherals: Docking, Mobile Monitors, Multi-Function Monitors, Portable/External hard drives, Dongles and accessories, etc.

## 4. Ordering information

Table 1. Ordering information

Type number	Topside marking	Package		
		Name	Description	Version
PTN5100DBS	51D0	HVQFN20	plastic thermal enhanced very thin quad flat package; no leads; 20 terminals; body 4 × 4 × 0.85 mm <sup>[2]</sup>	SOT917-4
PTN5100DABS	51DA	HVQFN20	plastic thermal enhanced very thin quad flat package; no leads; 20 terminals; body 4 × 4 × 0.85 mm <sup>[3]</sup>	SOT917-4

- [1] Total height after printed-circuit board mounting <=1 mm (maximum)  
 [2] Supported system interface - SPI  
 [3] Supported system interface - I<sup>2</sup>C

4.1 Ordering options

Table 2. Ordering options

Type number	Orderable part number	Package	Packing method	Minimum order quantity	Temperature
PTN5100DBS	PTN5100DBSMP	HVQFN20	Reel 13" Q2/T3 *standard mark SMD dry pack	6000	T <sub>amb</sub> = -20 °C to +85 °C
PTN5100DABS	PTN5100DABSMP	HVQFN20	Reel 13" Q2/T3 *standard mark SMD dry pack	6000	T <sub>amb</sub> = -20 °C to +85 °C

5. Block diagram

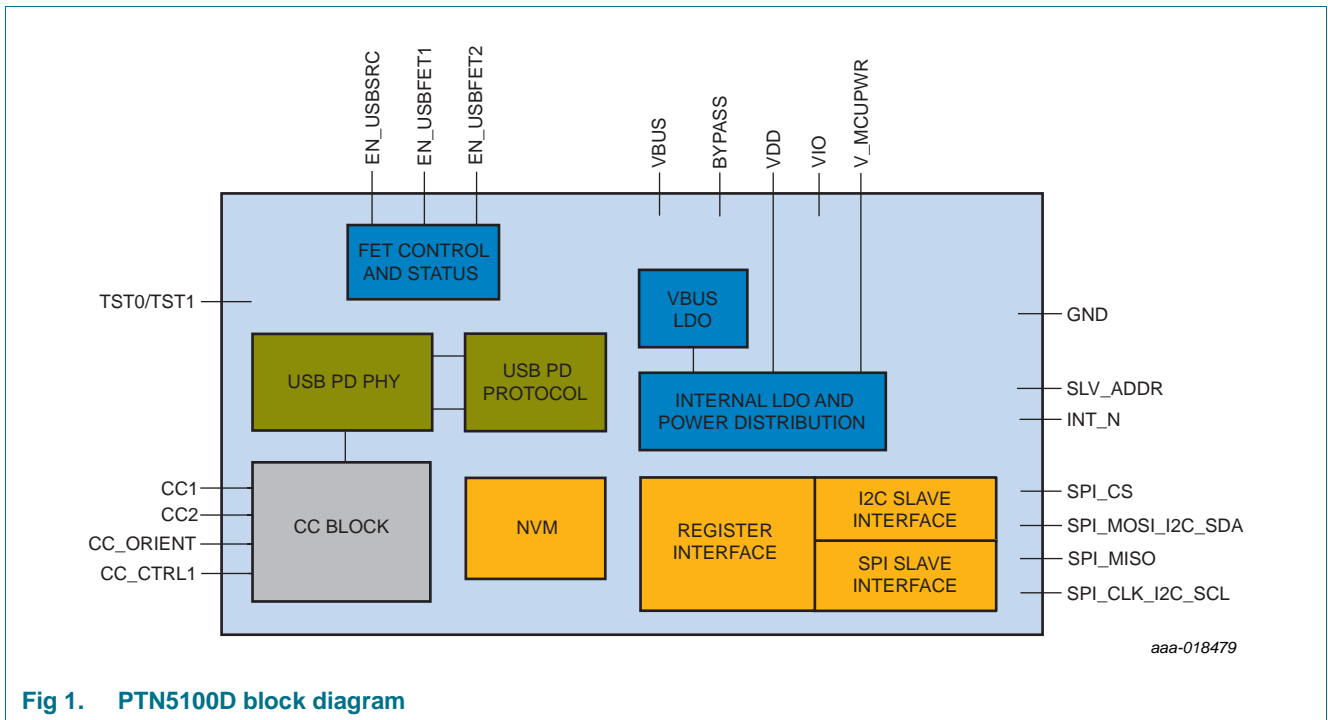

Fig 1. PTN5100D block diagram

## 6. Pinning information

### 6.1 Pinning

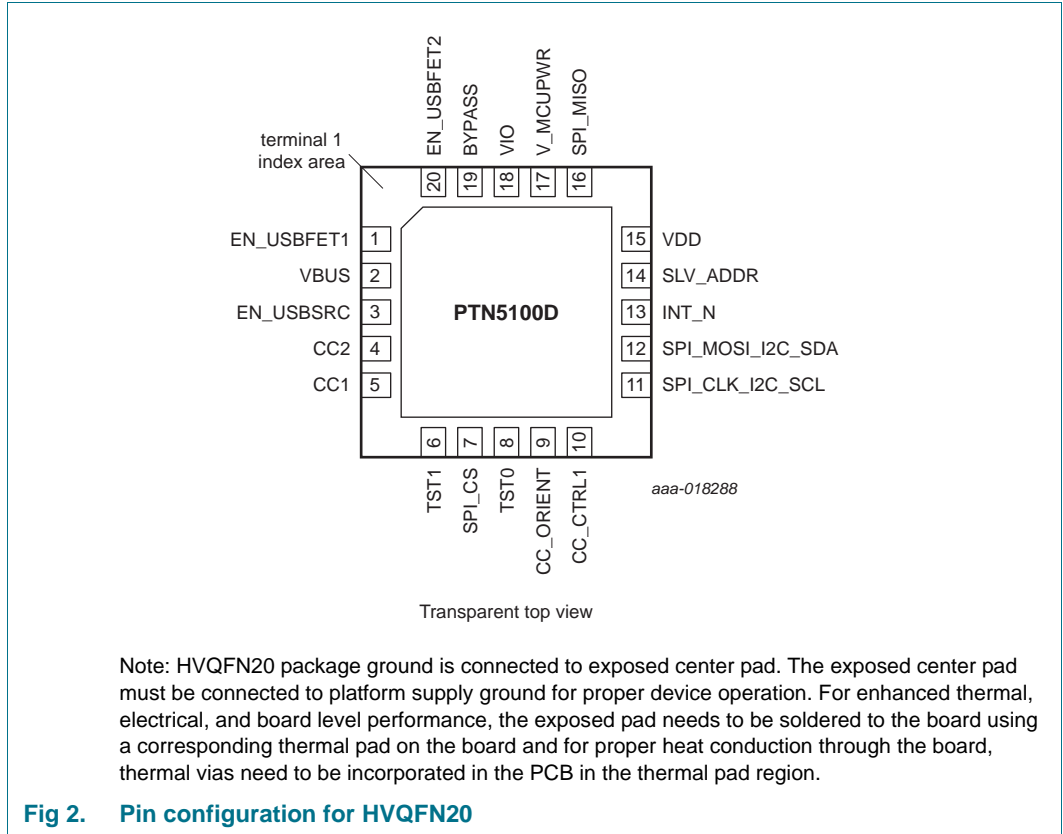

Fig 2. Pin configuration for HVQFN20

## 6.2 Pin description

Table 3. Pin description

Symbol	Pin	Pin direction	Pin Type	Description
EN_USBSRC	3	Output	Open drain	USB PD VBUS Source Power path PMOS FET gate Active Low enable. At default/POR, this pin is Hi-Z; PTN5100D drives this pin LOW based on Type-C connection state and/or policy controller MCU command. The pin status can be read in the internal register(s).
EN_USBFET1	1	Output	Open drain	USB PD VBUS Source or Sink Power path PMOS FET gate Active Low enable. At default/POR, this pin is Hi-Z; PTN5100D drives this pin LOW based on Type-C connection state and/or policy controller MCU command. The pin status can be read in the internal register(s).
EN_USBFET2	20	Output	Open drain	USB PD VBUS Source or Sink Power path PMOS FET gate Active Low enable. At default/POR, this pin is Hi-Z; PTN5100D drives this pin LOW based on policy controller MCU command. The pin status can be read in the internal register(s).
CC1	5	IO	Custom IO	Type-C Configuration channel #1 TVS or similar protection diode (e.g. PESD5V0S1USF, PESD5V0S1UL, etc.) shall be used to protect the CC1/2 pins from overshoot/undershoot during cable plug/unplug and cable discharge events.
CC2	4	IO	Custom IO	Type-C Configuration channel #2 TVS or similar protection diode (e.g. PESD5V0S1USF, PESD5V0S1UL, etc.) shall be used to protect the CC1/2 pins from overshoot/undershoot during cable plug/unplug and cable discharge events.
CC_ORIENT	9	Output	CMOS IO on VIO power rail	This pin indicates Type-C cable plug orientation. The pin's polarity is inverted at power-on reset and the PD policy controller MCU has to initialize PTN5100D before the pin level is valid. After the initialization, the pin indicates orientation as follows: LOW = Normal plug orientation (CC communication on CC1) HIGH = Reverse plug orientation (CC communication on CC2) Default pin value is LOW even if there is no connection or normal plug connection
CC_CTRL1	10	Input	Analog Input	Input to indicate whether to present 'Rd' or Open on CC pin under Unpowered condition
TST1	6	Output	CMOS IO on VIO power rail	Meant for Test purpose only. Do not connect in the application

Table 3. Pin description ...continued

Symbol	Pin	Pin direction	Pin Type	Description
TST0	8	Input	Power	Pin for Test purpose. This pin shall be connected to GND in customer applications.
SPI_MOSI_ I2C_SDA	12	IO	Open drain IO (I2C mode) referenced to VIO voltage V_MCUPWR power rail (SPI mode)	Dual purpose pin. In I2C slave mode, this serves as I2C data input/output (open drain) In SPI slave mode, this pin serves Master Output Slave Input function (push pull CMOS IO)
SPI_MISO	16	Output	V_MCUPWR rail	This serves Master Input Slave Output function of SPI interface
SPI_CLK_I2C_SCL	11	Input	Open drain IO (I2C mode) referenced to VIO voltage V_MCUPWR power rail (SPI mode)	Dual purpose pin. In I2C slave mode, this serves as I2C clock input (open drain). In SPI slave mode, it serves as SPI clock input pin
SPI_CS	7	Input	V_MCUPWR rail	This pin provides SPI chip select Input
INT_N	13	Output	Open drain	Level triggered interrupt. Open drain output; This pin needs to be externally pulled up VIO. This pin is usable only when VDD is valid
SLV_ADDR	14	Ternary input	V_MCUPWR rail	Ternary slave address (I2C) pin
V_MCUPWR	17	Output	Power	This pin delivers current up to 30 mA (max) to policy controller MCU. External supply de-coupling capacitor(s) (2.2 $\mu$ F $\pm$ 10 % ceramic capacitor) are required
VIO	18	Input	Power	IO domain power supply. External supply de-coupling capacitor(s) are required
VBUS	2	Input	Power	VBUS power supply. External supply de-coupling capacitor(s) are required
VDD	15	Input	Power	Core domain power supply. External supply de-coupling capacitor(s) are required
BYPASS	19	Internal	Internal power rail	Internal power rail. A ceramic capacitor (2.2 $\mu$ F $\pm$ 10 %) is to be connected to this pin
GND	Center pad		GND	Ground Center pad

## 7. Functional description

PTN5100D is a 1-port USB Type-C PD Physical and Protocol Layer IC that can be used to realize single or multi-port USB Type-C PD and/or Alternate mode implementations. It complies with USB PD [1] and Type-C specifications [2]. PTN5100D is required to be initialized after power-on by the PD policy controller MCU before the dedicated pin CC\_ORIENT behaves as specified in this data sheet specification.

PTN5100D can be partitioned into the following major functional blocks along with their respective interfaces:

- Type-C Configuration Channel functional block
- USB Power Delivery function
- Power FET Enable Control
- MCU interface and Control

The following subsections describe the PTN5100D with its major functional blocks.

### 7.1 Type-C Configuration Channel functional block

Type-C Configuration Channel (CC) function operates as a front end to cable/plug interface. This block implements Orientation detection, Cable/Plug insertion and removal detection as per [2].

PTN5100D can operate under MCU control. To support use cases, PTN5100D implements HW circuitry to perform the following operations:

- Applying 'Rp' or 'Rd' depending on the (NVM) configured role
- Detecting cable/plug connect and disconnect events
- Indicating Type-C current limit level in a system under DFP role
- Detecting the current level supported by remote end under UFP role
- Identifying plug orientation and indicating through CC\_ORIENT<sup>1</sup> pin
- Updating event, interrupt and status registers and raising interrupt signal using INT\_N pin

In order to provide reliable connect/disconnect event triggers, debouncing is also implemented as per [2].

PTN5100D allows for register programmability to enable usage under different platform configurations.

### 7.2 USB Power Delivery Function

In general, the Embedded Controller (EC) or System Management Controller (SMC) handles the overall Application/Platform power management given the system states, battery status, etc. It reviews capabilities and status of various power providers (USB PD,

1. The CC\_ORIENT pin's polarity is inverted at power-on and the PD policy controller MCU has to initialize PTN5100D before the pin level is valid

AC-DC adapter, battery, docking, etc.) dynamically and determines a specific source for powering/charging the platform - the power source selection is an important and platform dependent aspect of Application power delivery scheme.

- For example, in some applications, platform host processor plays a central role in controlling the various power sources including USB PD. To support this, PTN5100D and Policy controller MCU can be configured to negotiate and agree on power contract based on command/response exchanges with host processor
- In several applications, host processor may not even exist or it wants to play a hands-off role. To support these applications, PTN5100D and Policy controller MCU can be configured to operate autonomously

In a Type-C PD implementation, the system partitioning involves the following parts:

- Port PHY and Protocol layer functions → PTN5100D
- Port policy engine and device policy management, Alternate mode support → Discrete policy controller MCU
- System management → host processor

PTN5100D implements USB PD PHY layer and HW intensive Protocol functions and it works along with a discrete MCU to implement Full PD functionality. The combined 2-chip system solution (PTN5100D and MCU) can be configured to support one or more of the following PD roles:

1. PD Consumer
2. PD Consumer/Provider

The interface between PTN5100D and Policy controller MCU can be either SPI or I2C. PTN5100D provides a transparent set of commands and register interface for the MCU to control the operation and ensure safe/suitable system behavior/response. PTN5100D Application Programming guide [3] describes the register set supported for the PD control, status updates and operational control/sequences.

The policy controller MCU implements PD port policy layer as per [1]. The default PD power profiles are configured in the MCU and the host processor could request for specific profile and PD contract based on platform application. The 2-chip solution can operate autonomously or under host processor control.

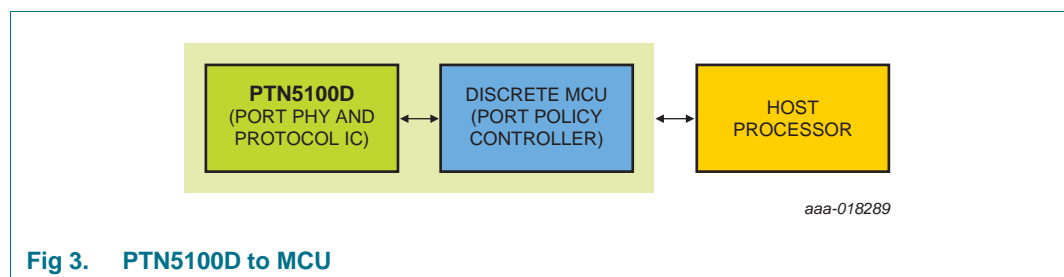
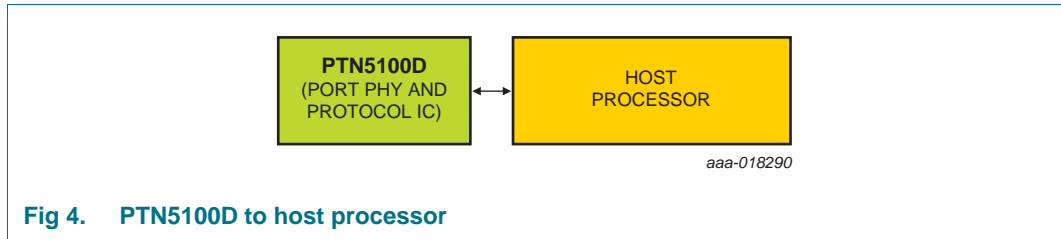

Fig 3. PTN5100D to MCU



PTN5100D implements USB PD PHY layer function as follows:

- Slew rate controlled IO
- Bit transmission and data recovery
- Bi-phase Mark Coding
- 4B5B Line coding
- CRC computation and checking

It handles the following Protocol layer functions:

- Data Packetization and Extraction
- Good CRC Response
- Automated Retries
- Hard reset, Cable reset
- Tx and Rx buffer management

It handles both Transmit and Receive operation and it maintains dedicated TX and RX data buffers. To minimize chances of collision, PTN5100D checks the CC line before start of transmission. Once the data is transmitted or received, the I2C interface status is updated and MCU is interrupted.

BIST mode (Tx, Rx) is also supported.

Note: NXP is open to engage on Firmware licensing to give a head start to customers on USB PD Policy and Alternate mode Firmware front. Please contact NXP for further details.

### 7.3 Power FET control

PTN5100D implements three dedicated open drain IOs that can be used to control the external power MOSFETs and enable/ disable VBUS source and sink power paths of the system. These are enabled or disabled based on PD power role (provider or consumer) of the Type-C interface. Based on PD negotiation and contract, the policy controller MCU enables/disables the specific power path (source FET or sink FETs).

- EN\_USBSRC: This pin is used to enable/disable the power MOSFETs that corresponds to VBUS source (e.g. 5V regulated output). The FET enable can be configured and controlled through the register interface by the MCU. The pin status is monitored and updated in a status register.
- EN\_USBFET1: This pin is used to enable/disable the power MOSFETs that corresponds to USB PD power from external power sources or delivering VBUS power to external peripherals. Its specific use as a VBUS source or sink path control

is programmable. The FET enable can be configured and controlled through the register interface by the MCU. The pin status is monitored and updated in a status register.

- EN\_USBFET2: This pin is used to enable/disable the power MOSFETs that corresponds to USB PD power from external power sources or delivering VBUS power to external peripherals. It specific use as a VBUS source or sink path control is programmable. The FET enable can be configured and controlled through the register interface by the MCU. The pin status is monitored and updated in a status register.

### 7.4 MCU interface and control

PTN5100D works along with policy controller MCU to realize USB PD functionality and/or Alternate mode support. The MCU can control and interface with PTN5100D through a dedicated I2C/SPI interface. In a given system implementation, only one of the two interfaces (I2C, SPI) can be used.

PTN5100D provides up to three I2C slave address combinations based on ternary pin (SLV\_ADDR) setting as per the table below.

Table 4. I2C slave address combinations

SLV_ADDR pin	Device address (Write/read)
GND	0xE0/0xE1
VDDIO	0xE4/0xE5
Unconnected	0xE8/0xE9

#### 7.4.1 I<sup>2</sup>C-bus interface

PTN5100D has a slave I2C interface through which it provides a mechanism for control and status interaction/communication with the MCU. It supports Standard mode, Fast mode and Fast mode plus.

##### 7.4.1.1 I2C writes

The following figure shows the basic protocol for I2C writes. A 16-bit offset is used to address each register.

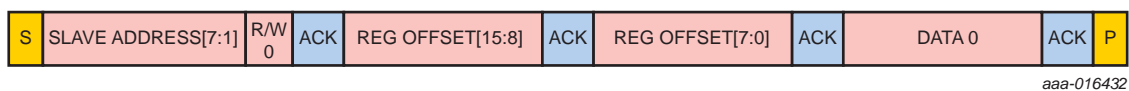

Fig 5. I2C writes

##### 7.4.1.2 I2C reads

The following figure shows the basic protocol for I2C reads. They start off like I2C writes by specifying a 16-bit register offset. This is followed by a repeat start condition, the Slave Address (Read), and the read data.

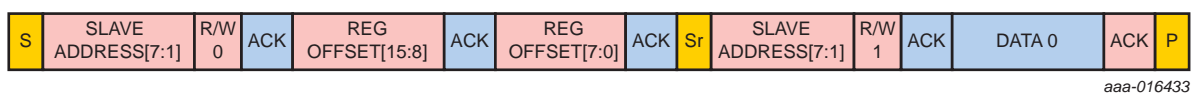

Fig 6. I2C reads

#### 7.4.1.3 I2C address auto-incrementing

Bursts are allowed during writes and reads. Bit 15 of the register offset is the auto-increment indication. If '0' then the internally generated MMIO address will not increment with each data byte. If '1', then the address will increment with each data byte.

A detailed description of the I<sup>2</sup>C-bus specification, with applications, is given in user manual UM10204, "I<sup>2</sup>C-bus specification and user manual" [4]. Referring to I2C protocol, PTN5100D positively acknowledges all 256 register offset addresses, though there are certain undefined address offsets.

#### 7.4.2 SPI interface

PTN5100D provides an SPI slave interface as well. It supports SPI modes 1 and 2. This interface exposes same register interface as that of I2C. Its main advantage is faster command and data transport and relaxes MCU response time/latency requirements.

#### 7.4.3 Register interface

PTN5100D Application programming guide [3] describes the various registers with their bit definitions, POR values and the various functions. Also, sample 'C' programs corresponding to various functions and operations are given. This guide can be used by the platform system architects to implement the EC firmware to control the operations with PTN5100D. Refer to programming guide for more information. The register definitions are also described in the guide.

#### 7.4.4 Relevant Interface pins - SLV\_ADDR, SPI\_CLK\_I2C\_SCL, SPI\_MOSI\_I2C\_SDA, SPI\_CS, SPI\_MISO, INT\_N

- SLV\_ADDR is a ternary input pin that is used to support up to 3 slave PTN5100D devices on a given platform. This pin can be pulled to V\_MCUPWR rail, left open or pulled to GND.
- While in SPI mode, SPI\_CLK\_I2C\_SCL, SPI\_MISO, SPI\_MOSI\_I2C\_SDA and SPI\_CS provide the necessary interface for connecting to SPI master controller on the MCU.
- While in I2C mode, SPI\_CLK\_I2C\_SCL and SPI\_MOSI\_I2C\_SDA are used for I2C clock and data interfacing to MCU
- INT\_N pin is used to raise Active LOW level triggered interrupt signal to EC. PTN5100D processes various events and raises interrupt that require SMC intervention. Once all relevant events are processed by the MCU, the INT\_N pin goes HIGH. At POR, this pin remains HIGH (when VIO is valid). The specific events that can generate the interrupt can be selected.

### 7.5 Power supplies

PTN5100D is designed to operate under various power supplies. It can operate under both normal battery and dead battery environments (while drawing power from VBUS). PTN5100D handles power supply transitions (VBUS, VDD) transparently and there is no specific power supply ramp requirement imposed on the system (between VDD and VIO rails) also.

The following table highlights the power supplies and operating conditions for PTN5100D.

Table 5. Power supplies vs. operating conditions

Valid power supply input combination	Operational condition	Remarks
VDD, VIO	Normal powered condition (both battery based or non-battery based platforms)	All interfaces operational
VDD, VIO, VBUS	Normal powered condition; Host Platform may be powered/charged through VBUS simultaneously	All interfaces operational
VBUS, VIO(=V_MCUPWR)	Dead battery in battery based platforms or Normal powered condition under other platforms; Host Platform powered/charged through USB PD	All interfaces operational
VBUS	Dead battery operation; PTN5100D draws power from VBUS for its operation; Host Platform may be powered/charged through USB PD later	PTN5100D pins (dependent on VIO rail) are not operational

**Remark:** The Policy controller MCU is powered by PTN5100D.

The relevant pins associated with this functional block are:

- VDD
- VIO
- VBUS
- V\_MCUPWR
- BYPASS

## 8. PTN5100D - Use case view

Given that USB Power Delivery could address the requirements of a wide set of markets and product segments, PTN5100D is designed to work over a range of product categories, platform applications, use cases and usage roles. With its configurability, it can serve the needs of both general and custom applications. Not limited to these but the following subsection illustrates a use case for PTN5100D.

8.1 System use case illustration

8.1.1 Type-C cable adapter with PTN5100D

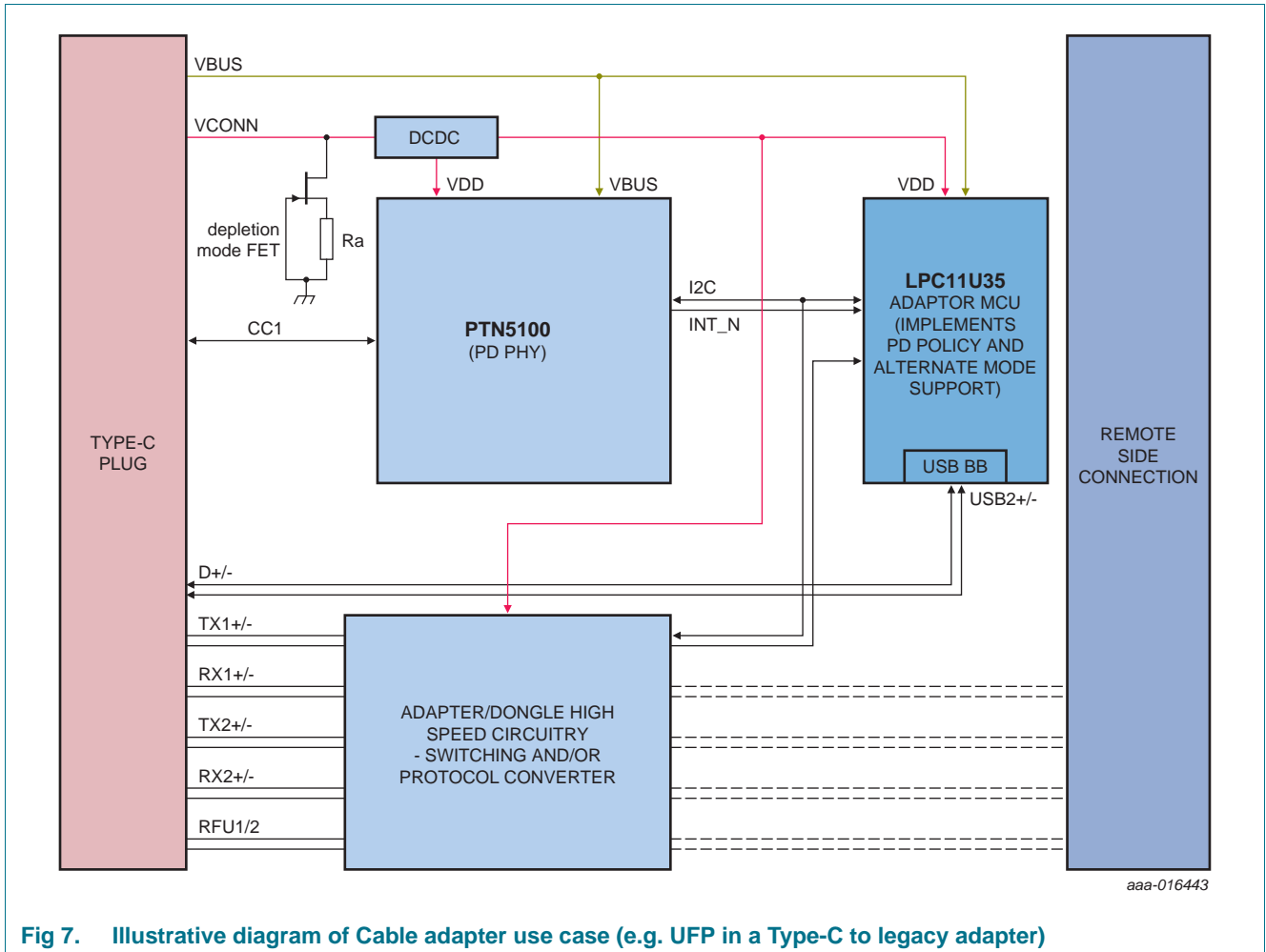

Fig 7. Illustrative diagram of Cable adapter use case (e.g. UFP in a Type-C to legacy adapter)

8.1.1.1 Application description

In this illustration, PTN5100D is inside Type-C cable adapter operating in UFP role. Some example use cases are Type-C to DP adapter, Type-C to VGA adapter, Type-C to Thunderbolt adapter etc. PTN5100D serves as PD PHY layer device for a Cable adapter management MCU or dedicated PD MCU wherein PD policy management, Alternate mode and VDM support are handled. The USB Billboard device is implemented as part of adapter management MCU.

The cable adapter implementation operates on VCONN and/or VBUS supply. Discrete depletion mode FET has to be used in the application for 'Ra' indication.

TVS protection diode (e.g. PESD5V0S1USF, PESD5V0S1UL, etc.) shall be used to protect the CC1/2 pins from overshoot/undershoot during cable plug/unplug and cable discharge events.

## 9. Limiting values

**Table 6. Limiting values**

*In accordance with the Absolute Maximum Rating System (IEC 60134).*

Symbol	Parameter	Conditions	Min	Max	Unit
V <sub>DD</sub>	supply voltage		-0.5	+4.6	V
V <sub>IO</sub>	IO voltage		-0.5	+4.6	V
V <sub>BUS</sub>	USB VBUS voltage		-0.5	+28	V
V <sub>I</sub>	Input voltage	voltage at the pin			
		CC_CTRL1, CC_ORIENT	-0.5	+4.6	V
		CC1, CC2	-0.5	+6.0	V
		EN_USBSRC, EN_USBFET1, EN_USBFET2	-0.5	+28	V
		BYPASS	-0.5	+2.5	V
		INT_N	-0.5	+4.6	V
		SLV_ADDR	-0.5	+4.6	V
		SPI_CLK_I2C_SCL, SPI_MOSI_SDA, SPI_MISO, SPI_CS	-0.5	+4.6	V
T <sub>stg</sub>	Storage temperature		-65	+150	°C
V <sub>ESD</sub>	electrostatic discharge voltage	HBM: VBUS, CC1, CC2 <a href="#">[1][2]</a>	8000	-	V
		HBM for internal pins: <a href="#">[2]</a> CC_CTRL1, CC_ORIENT, BYPASS, VDD, VIO, INT_N, SLV_ADDR, SPI, EN_USBFET1, EN_USBFET2 and EN_USBSRC signals	1500	-	V
		CDM <a href="#">[3]</a>	1000	-	V

[1] All voltage values, except differential voltages, are with respect to network ground terminal.

[2] Human Body Model: ANSI/ESDA/JEDEC JDS-001-2012 (Revision of ANSI/ESDA/JEDEC JS-001-2011), ESDA/JEDEC Joint standard for ESD sensitivity testing, Human Body Model - Component level; Electrostatic Discharge Association, Rome, NY, USA; JEDEC Solid State Technology Association, Arlington, VA, USA.

[3] Charged Device Model: JESD22-C101E December 2009 (Revision of JESD22-C101D, October 2008), standard for ESD sensitivity testing, Charged Device Model - Component level; JEDEC Solid State Technology Association, Arlington, VA, USA.

## 10. Recommended operating conditions

Table 7. Operating conditions

Symbol	Parameter	Conditions	Min	Typ	Max	Unit
VDD	System supply voltage		3.0	-	3.6	V
VIO	System IO supply voltage	when 3.3 V supply is used	3.0	-	3.6	V
		when 1.8 V supply is used	1.7	-	1.9	V
VBUS	USB VBUS voltage		3.7	-	25	V
V <sub>I</sub>	input voltage on the pin			-		
		CC_CTRL1, CC_ORIENT	-0.3	-	3.6	V
		CC1, CC2	-0.3	-	5.5	V
		EN_USBSRC, EN_USBFET1, EN_USBFET2	-0.3	-	25	V
		INT_N	-0.3	-	3.6	V
		SLV_ADDR	-0.3	-	3.6	V
T <sub>amb</sub>	Ambient Operating temperature		-20	-	+85	°C

## 11. Characteristics

### 11.1 Device characteristics

**Table 8. Device characteristics**

Applicable across operating temperature and power supply ranges as per [Section 10](#) (unless otherwise noted). Typical values are specified at 27 °C (unless otherwise noted).

Symbol	Parameter	Conditions	Min	Typ	Max	Unit
$T_{FET\_EN}$	Time duration between I2C write/ACK and FET enable asserted	Applicable to all FET enable pins	-	-	10	$\mu$ s
$T_{FET\_DIS}$	Time duration between I2C write/ACK and FET enable de-asserted	Applicable to all FET enable pins	-	-	10	$\mu$ s
$I_{DD,Active}$	Active mode operating current	UFP role; attached condition; $V_{DD} = 3.3$ V	-	200	-	$\mu$ A
		SPI interface is active	-	3	-	mA
		PD mode is functional; does not include power delivered on V_MCUPWR pin; $V_{DD} = 3.3$ V	-	3	-	mA
$I_{DD(idle)}$	Idle mode current on VDD	UFP role; Unattached condition	-	50	-	$\mu$ A
$I_{VIO(idle)}$	Idle mode supply current (VIO)		-	-	10	$\mu$ A
$I_{bckdrv}$	Backdrive current	Backdrive current on VDD pin when that pin is at 0 V				
		CC1, CC2 = 5 V	-10	-	10	$\mu$ A

## 11.2 USB PD and Type-C characteristics

**Table 9. USB PD and Type-C AC/DC characteristics**

Applicable across operating temperature and power supply ranges as per [Section 10](#) (unless otherwise noted). Typical values are specified at 27 °C (unless otherwise noted).

Symbol	Parameter	Conditions	Min	Typ	Max	Unit
<b>USB PD normative specification</b>						
f <sub>Bitrate</sub>	Bit rate		270	300	330	Kbps
t <sub>UnitInterval</sub>	unit interval		3.03	-	3.7	μs
P <sub>BitRate</sub>	Maximum difference between the bit-rate during the payload and the reference bit-rate (The reference bit rate is the average bit rate of the last 32 bits of the preamble)	At the transmitter	-	-	0.25	%
t <sub>InterFrameGap</sub>	Time from the end of last bit of a Frame until the start of the first bit of the next Preamble.		25	-	-	μs
t <sub>StartDrive</sub>	Time before the start of the first bit of the Preamble when the transmitter shall start driving the line.		-1	-	-	μs
<b>USB PD transmitter normative specification</b>						
t <sub>EndDriveBMC</sub>	Time to cease driving the line after the end of the last bit of the Frame.	Min value is limited by t <sub>HoldLowBMC</sub>	-	-	23	μs
t <sub>Fall</sub>	Fall time	10 % and 90 % amplitude points, minimum is under unloaded condition	300	-	-	ns
t <sub>HoldLowBMC</sub>	Time to cease driving the line after the final high-to-low transition	Max value is limited by t <sub>EndDriveBMC</sub>	1	-	-	us
t <sub>Rise</sub>	Rise time	10 % and 90 % amplitude points, minimum is under unloaded condition	300	-	-	ns
V <sub>Swing</sub>	Voltage swing		1.05	1.125	1.2	V
Z <sub>Driver</sub>	Transmitter output impedance	Source output impedance at the Nyquist frequency of [USB2.0] low speed (750 kHz) while the source is driving the CC line.	33	-	75	Ω
<b>USB PD receiver normative specification</b>						
C <sub>Receiver</sub>	CC Receiver capacitance	The CC pin (DFP or UFP) capacitance when not transmitting on the line	200	-	600	pF
n <sub>TransitionCount</sub>	Transitions for signal detect		3	-	-	
t <sub>RxFilter</sub>	Time constant of Rx bandwidth limiting filter		100	-	-	ns

**Table 9. USB PD and Type-C AC/DC characteristics ...continued**

Applicable across operating temperature and power supply ranges as per [Section 10](#) (unless otherwise noted). Typical values are specified at 27 °C (unless otherwise noted).

Symbol	Parameter	Conditions	Min	Typ	Max	Unit
$t_{\text{TransitionWindow}}$	Time window for detecting non-idle		12	-	20	$\mu\text{s}$
$Z_{\text{BmcRx}}$	Receiver Input Impedance		1	-	-	$\text{M}\Omega$
<b>Type-C specification</b>						
$I_{\text{pullup}}$	Current source for DFP pullup indication	Default current	76	80	84	$\mu\text{A}$
		1.5 A	171	180	189	$\mu\text{A}$
		3 A	314	330	346	$\mu\text{A}$
$R_{\text{pulldn}}$	Pulldown termination on UFP	After on-board calibration is completed	4.6	5.1	5.6	$\text{k}\Omega$
$Z_{\text{OPEN}}$	UFP CC termination	Applies to self-powered UFP to remain undetectable by DFP	126	-	-	$\text{k}\Omega$
$V_{\text{CLAMPH}}$	High current mode clamp voltage	UFP mode; VDD = 0, VBUS = 0	0.85	-	2.18	V
$V_{\text{CLAMPM}}$	Medium current mode clamp voltage	UFP mode; VDD = 0, VBUS = 0	0.45	-	1.25	V
$V_{\text{CLAMPD}}$	Default current mode clamp voltage	UFP mode; VDD = 0, VBUS = 0	0.25	-	1.25	V
$V_{\text{TUM}}$	Medium current mode detection threshold	UFP mode	1.16	1.23	1.31	V
$V_{\text{TUS}}$	Standard current mode detection threshold	UFP mode	0.61	0.66	0.70	V
$V_{\text{TURa}}$	Powered Accessory (Ra) mode detection threshold	UFP mode	0.15	0.2	0.25	V
$V_{\text{TDH,Ra}}$	High current mode Ra detection threshold	DFP mode	0.75	0.8	0.85	V
$V_{\text{TD,Rd}}$	Rd detection threshold	DFP mode	2.45	2.6	2.75	V
$V_{\text{TDM,Ra}}$	Medium current mode Ra detection threshold	DFP mode	0.35	0.4	0.45	V
$V_{\text{TDS,Ra}}$	Standard current mode Ra detection threshold	DFP mode	0.15	0.2	0.25	V

[1] At present, only a limited set is listed out here; future data sheet revision would include all mandatory Type-C specifications [2].

### 11.3 Power AC/DC characteristics

**Table 10. Power AC/DC characteristics**

Applicable across operating temperature and power supply ranges as per [Section 10](#) (unless otherwise noted). Typical values are specified at 27 °C (unless otherwise noted).<sup>[1]</sup>

Symbol	Parameter	Conditions	Min	Typ	Max	Unit
V <sub>MCUPWR</sub>	DC Voltage on V_MCUPWR pin	Applies to both VBUS and VDD	2.5	-	3.6	V
I <sub>MCUPWR</sub>	DC Current delivered out of V_MCUPWR pin	Applies to both VBUS and VDD;  2.2 µF ±10 % De-coupling capacitor on V_MCUPWR pin	-	-	30	mA
I <sub>inrush</sub>	Inrush current	2.2 µF capacitors on BYPASS and V_MCUPWR pins, these pins are at 0 V	-	150	-	mA
V <sub>OUT_load</sub>	V_MCUPWR voltage	VBUS @ 3.7 V, load current 30 mA	2.5	-	3.6	V
V <sub>Line_reg</sub>	Line voltage regulation	VBUS sweep 3.7 V to 25 V; load current 30 mA	-	-	200	mV
V <sub>Load_reg</sub>	Load voltage regulation	VBUS @ 3.7 V; load current sweep 0 mA to 30 mA	-	-	50	mV
V <sub>Load_step</sub>	Load voltage variation under load step	VBUS @ 3.7 V; load current step from 0 to 30 mA over 30 µS interval	-	-	150	mV
PSRR	Power supply rejection ratio	VBUS @ 3.7 V to 25 V				
		DC	-	70	-	dB
		F = 100 kHz	-	50	-	dB
		F = 1 MHz	-	30	-	dB

[1] For all the specification measurements, supply decoupling capacitor 2.2 µA ±10 % is considered to be present on V\_MCUPWR pin. Also, the capacitor is charged up to V\_MCUPWR voltage unless otherwise specified.

### 11.4 I2C characteristics

**Table 11. I2C characteristics**

Applicable across operating temperature and power supply ranges as per [Section 10](#) (unless otherwise noted). Typical values are specified at 27 °C (unless otherwise noted).<sup>[1]</sup>

Symbol	Parameter	Conditions	Min	Typ	Max	Unit
f <sub>I2C</sub>	I2C clock frequency		0	-	1000	kHz
V <sub>IH</sub>	HIGH-level Input voltage		0.7 × VDDIO	-	-	V
V <sub>IL</sub>	LOW-level Input voltage		-	-	0.3 × VDDIO	V
V <sub>hys</sub>	Hysteresis of Schmitt trigger inputs	VDDIO > 2 V	0.05× VDDIO	-	-	V
		VDDIO < 2 V	0.1×VDDIO	-	-	V
V <sub>OL</sub>	LOW-level output voltage at 3mA sink current	VDDIO > 2 V	0	-	0.4	V
		VDDIO < 2 V	0	-	0.2× VDDIO	V

**Table 11. I2C characteristics ...continued**

Applicable across operating temperature and power supply ranges as per [Section 10](#) (unless otherwise noted). Typical values are specified at 27 °C (unless otherwise noted).<sup>[1]</sup>

Symbol	Parameter	Conditions	Min	Typ	Max	Unit
I <sub>OL</sub>	LOW-level output current	V <sub>OL</sub> = 0.4 V; Standard and Fast modes	3	-	-	mA
		V <sub>OL</sub> = 0.4 V; Fast mode plus	20	-	-	mA
		V <sub>OL</sub> = 0.6 V; Fast mode	6	-	-	mA
I <sub>IL</sub>	LOW-level input current	Pin voltage - 0.1×V <sub>DDIO</sub> to 0.9×V <sub>IO</sub> , max	-10	-	10	μA
C <sub>I</sub>	Capacitance of IO pin		-	-	10	pF
t <sub>HD,STA</sub>	Hold time (repeated) START condition	Fast mode plus; After this period, the first clock pulse is generated	0.26	-	-	μs
t <sub>LOW</sub>	LOW period of I2C clock	Fast mode plus	0.5	-	-	μs
t <sub>HIGH</sub>	HIGH period of I2C clock	Fast mode plus	0.26	-	-	μs
t <sub>SU,STA</sub>	Setup time (repeated) START condition	Fast mode plus	0.26	-	-	μs
t <sub>HD,DAT</sub>	Data Hold time	Fast mode plus	0	-	-	μs
t <sub>SU,DAT</sub>	Data Setup time	Fast mode plus	50	-	-	ns
t <sub>r</sub>	Rise time of I2C_SCL and I2C_SDA signals	Fast mode plus	-	-	120	ns
t <sub>f</sub>	Fall time of I2C_SCL and I2C_SDA signals	Fast mode plus	-	-	120	ns
t <sub>SU,STO</sub>	Setup time for STOP condition	Fast mode plus	0.26	-	-	μs
t <sub>BUF</sub>	Bus free time between STOP and START condition	Fast mode plus	0.5	-	-	μs
t <sub>VD,DAT</sub>	Data valid time	Fast mode plus	0.45	-	-	μs
t <sub>VD,ACK</sub>	Data valid acknowledge time	Fast mode plus	0.45	-	-	μs
t <sub>SP</sub>	Pulse width of spikes that must be suppressed by input filter		-	-	50	ns

[1] V<sub>DDIO</sub> is I2C-bus pull up voltage.

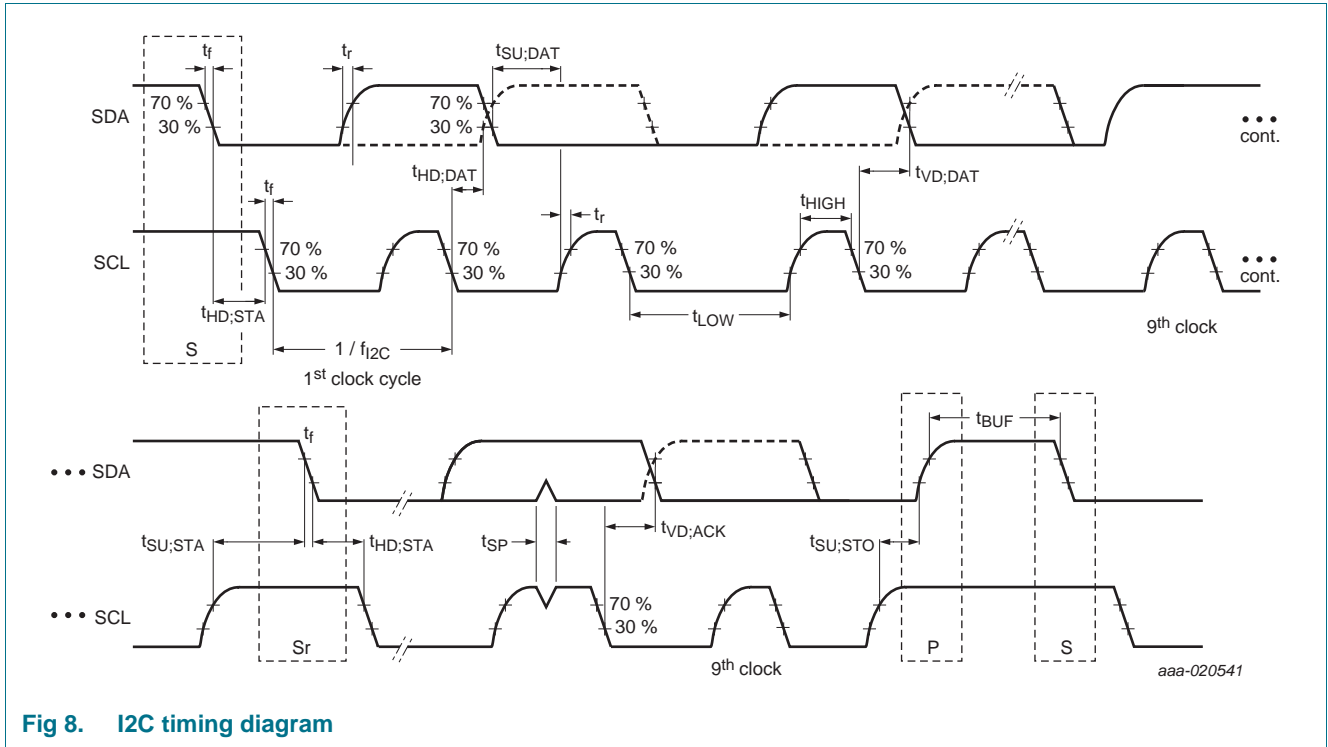

Fig 8. I2C timing diagram

## 11.5 SPI characteristics

**Table 12. SPI interface: AC/DC characteristics**

Applicable across operating temperature and power supply ranges as per [Section 10](#) (unless otherwise noted). Typical values are specified at 27 °C (unless otherwise noted).

Symbol	Parameter	Conditions	Min	Typ	Max	Unit
f <sub>SPI</sub>	SPI clock frequency (SPI_CLK)	Applies to both TX and RX	-	-	20	MHz
t <sub>SPI;HI</sub>	SPI clock HIGH time		20	-	-	ns
t <sub>SPI;LO</sub>	SPI clock LOW time		20	-	-	ns
t <sub>SPI;rise</sub>	SPI clock (LOW to HIGH) rise time		0.1	-	-	V/ns
t <sub>SPI;fall</sub>	SPI clock (HIGH to LOW) fall time		0.1	-	-	V/ns
t <sub>SPI;CSNS</sub>	SPI_CS Not Setup time	Relative to SPI clock pin	0	-	-	ns
t <sub>SPI;CSNH</sub>	SPI_CS Not Hold time	Relative to SPI clock pin	0	-	-	ns
t <sub>SPI;DINS</sub>	Data In Setup time	Applies to SPI_MOSI_I2C_SDA; relative to SPI clock	5	-	-	ns
t <sub>SPI;DINH</sub>	Data In Hold time	Applies to SPI_MOSI_I2C_SDA; relative to SPI clock	5	-	-	ns
t <sub>SPI;DONS</sub>	SPI clock edge to Valid Data Out	Applies to SPI_MISO	-	-	7	ns
t <sub>SPI;DONH</sub>	SPI clock edge to Data Out Hold time	Applies to SPI_MISO	0	-	-	ns
C <sub>L;SPI</sub>	Maximum IO capacitance supported	SPI_CLK_I2C_SCL, SPI_MOSI_I2C_SDA	-	-	10	pF
C <sub>IN;SPI</sub>	Maximum IO capacitance	SPI_MISO, SPI_CS	-	-	10	pF
V <sub>IH;SPI</sub>	HIGH-level input voltage	SPI_MISO	0.7× V <sub>MCUP</sub> WR	-	-	V
V <sub>IL;SPI</sub>	LOW-level input voltage	SPI_MISO	-	-	0.3× V <sub>MCU</sub> PWR	V
V <sub>OL;SPI</sub>	LOW-level output voltage	SPI_CLK_I2C_SCL, SPI_CS, SPI_MOSI_I2C_SDA IOL = 4 mA	-	-	0.5	V
V <sub>OH;SPI</sub>	HIGH-level output voltage	SPI_CLK_I2C_SCL, SPI_CS, SPI_MOSI_I2C_SDA IOH = -4 mA	V <sub>MCUP</sub> WR - 0.5	-	-	V
I <sub>LIH;EN</sub>	HIGH-level input leakage current	VI = 3.3 V	-1	-	1	μA
I <sub>LIL;EN</sub>	LOW-level input leakage current	VI = GND	-1	-	1	μA

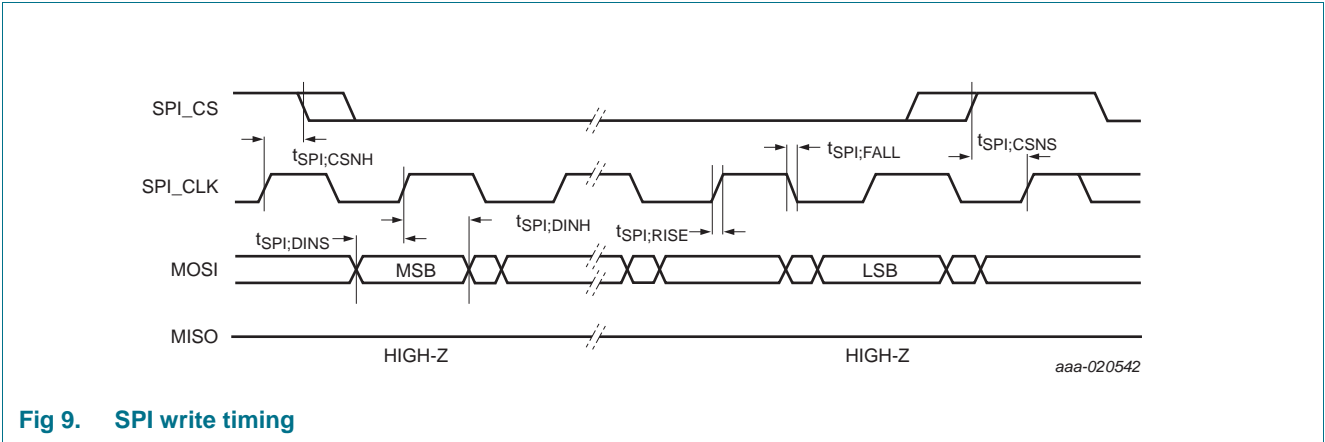

Fig 9. SPI write timing

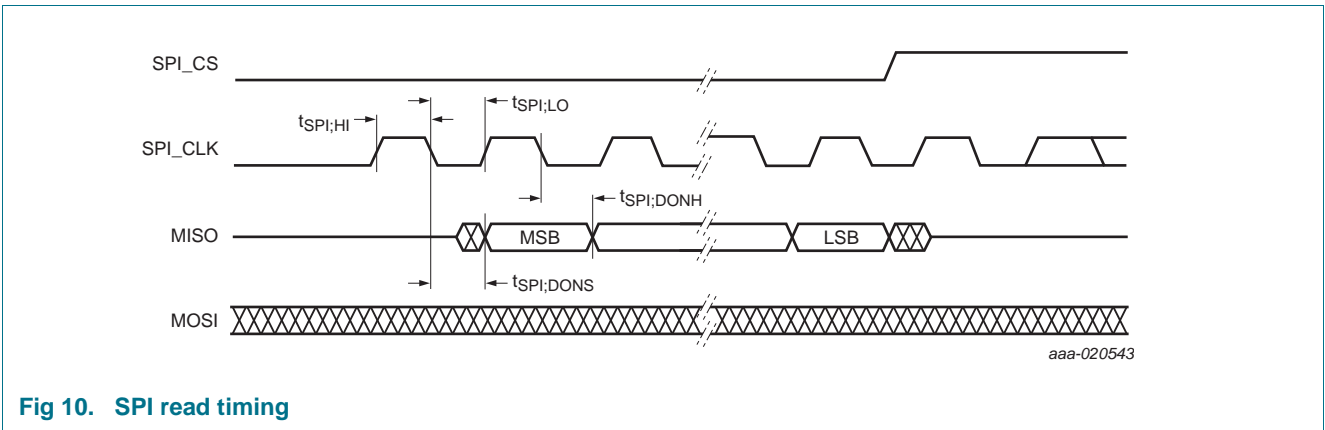

Fig 10. SPI read timing

### 11.6 CONTROL IO characteristics

Table 13. Control I/O characteristics

Applicable across operating temperature and power supply ranges as per Section 10 (unless otherwise noted). Typical values are specified at 27 °C (unless otherwise noted).

Symbol	Parameter	Conditions	Min	Typ	Max	Unit
<b>System side CMOS output pins (CC_ORIENT)</b>						
$V_{OH}$	HIGH-level Output voltage	$I_{OH} = -2 \text{ mA}$	$V_{IO} - 0.4$	-		V
$V_{OL}$	LOW-level Output voltage	$I_{OL} = 4 \text{ mA}$	-	-	0.5	V
$C_I$	Capacitance of IO pin		-	-	20	pF
$I_{LIH,EN}$	HIGH-level input leakage current	$V_I = 3.3 \text{ V}$	-1	-	1	$\mu\text{A}$
$I_{LIL,EN}$	LOW-level input leakage current	$V_I = \text{GND}$	-1	-	1	$\mu\text{A}$
<b>System side input pins (CC_CTRL1, SLV_ADDR, TST0)</b>						
$V_{IL}$	LOW-level input voltage	applies to CC_CTRL1, TST0	-	-	0.4	V
		applies to SLV_ADDR	-	-	$0.3 \times V_{DD}$	V

**Table 13. Control I/O characteristics**

Applicable across operating temperature and power supply ranges as per [Section 10](#) (unless otherwise noted). Typical values are specified at 27 °C (unless otherwise noted).

Symbol	Parameter	Conditions	Min	Typ	Max	Unit
$V_{IH}$	HIGH-level input voltage	applies to SLV_ADDR	$0.7 \times V_{DD}$	-	-	V
$C_I$	Capacitance of IO pin	applies to CC_CTRL1 only	-	-	20	pF
		applies to SLV_ADDR	-	-	20	pF
$I_{LIH,EN}$	HIGH-level input leakage current	$V_I = 3.3\text{ V}$	-1	-	1	$\mu\text{A}$
$I_{LIL,EN}$	LOW-level input leakage current	$V_I = \text{GND}$	-1	-	1	$\mu\text{A}$
<b>System side open drain interface pins (INT_N); pulled up to VDDIO</b>						
$V_{OL}$	LOW-level Output voltage	$I_{OL} = 4\text{ mA}$	-	-	0.5	V
$C_I$	Capacitance of IO pin		-	-	20	pF
<b>FET enable pins (EN_USBSRC, EN_USBFET1, EN_USBFET2)</b>						
$V_{OL,EN}$	LOW-level output voltage	$I_{OL} = 4\text{ mA};$	-	-	0.5	V
$V_{IH,EN}$	HIGH-level input voltage	FET enable pins are in Hi-Z	$0.7 \times V_{MCUPWR}$	-	25	V
$I_{LIH,EN}$	HIGH-level input leakage current	$V_I = 25\text{ V}$	-1	-	1	$\mu\text{A}$
$I_{LIL,EN}$	LOW-level input leakage current	$V_I = \text{GND}$	-1	-	1	$\mu\text{A}$

[1] VFET\_Bias is the bias voltage on the FET enable pins

12. Package outline

HVQFN20: plastic thermal enhanced very thin quad flat package; no leads;  
20 terminals; body 4 x 4 x 0.85 mm

SOT917-4

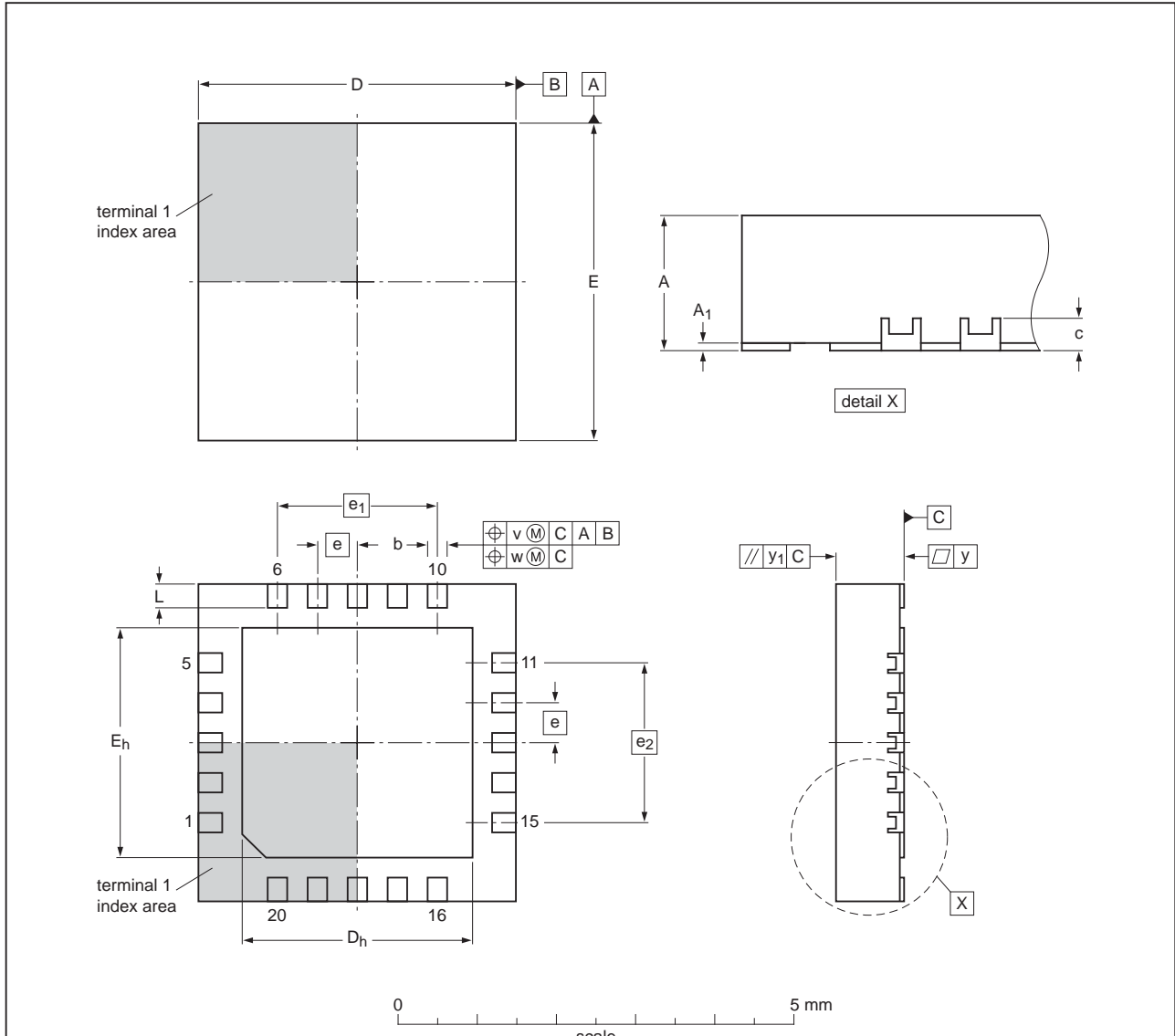

Dimensions

Unit	A	A <sub>1</sub>	b	c	D <sup>(1)</sup>	D <sub>h</sub>	E <sup>(1)</sup>	E <sub>h</sub>	e	e <sub>1</sub>	e <sub>2</sub>	L	v	w	y	y <sub>1</sub>
max	1.00	0.05	0.30		4.1	3.0	4.1	3.0				0.35				
nom	0.85		0.25	0.2	4.0	2.9	4.0	2.9	0.5	2	2	0.30	0.1	0.05	0.08	0.1
min	0.80		0.20		3.9	2.8	3.9	2.8				0.25				

Note

1. Plastic or metal protrusions of 0.075 mm maximum per side are not included.

sot917-4\_po

Outline version	References			European projection	Issue date
	IEC	JEDEC	JEITA		
SOT917-4		MO-220	---		14-10-27 14-11-07

Fig 11. Package outline SOT917-4 (HVQFN20)

### 13. Packing information

**13.1 SOT917-4: HVQFN20; Reel dry pack, SMD, 13"; Q2/T3 turned product orientation; Orderable part number ending ,528 or MP; Ordering code (12NC) ending 528**

**13.1.1 Packing method**

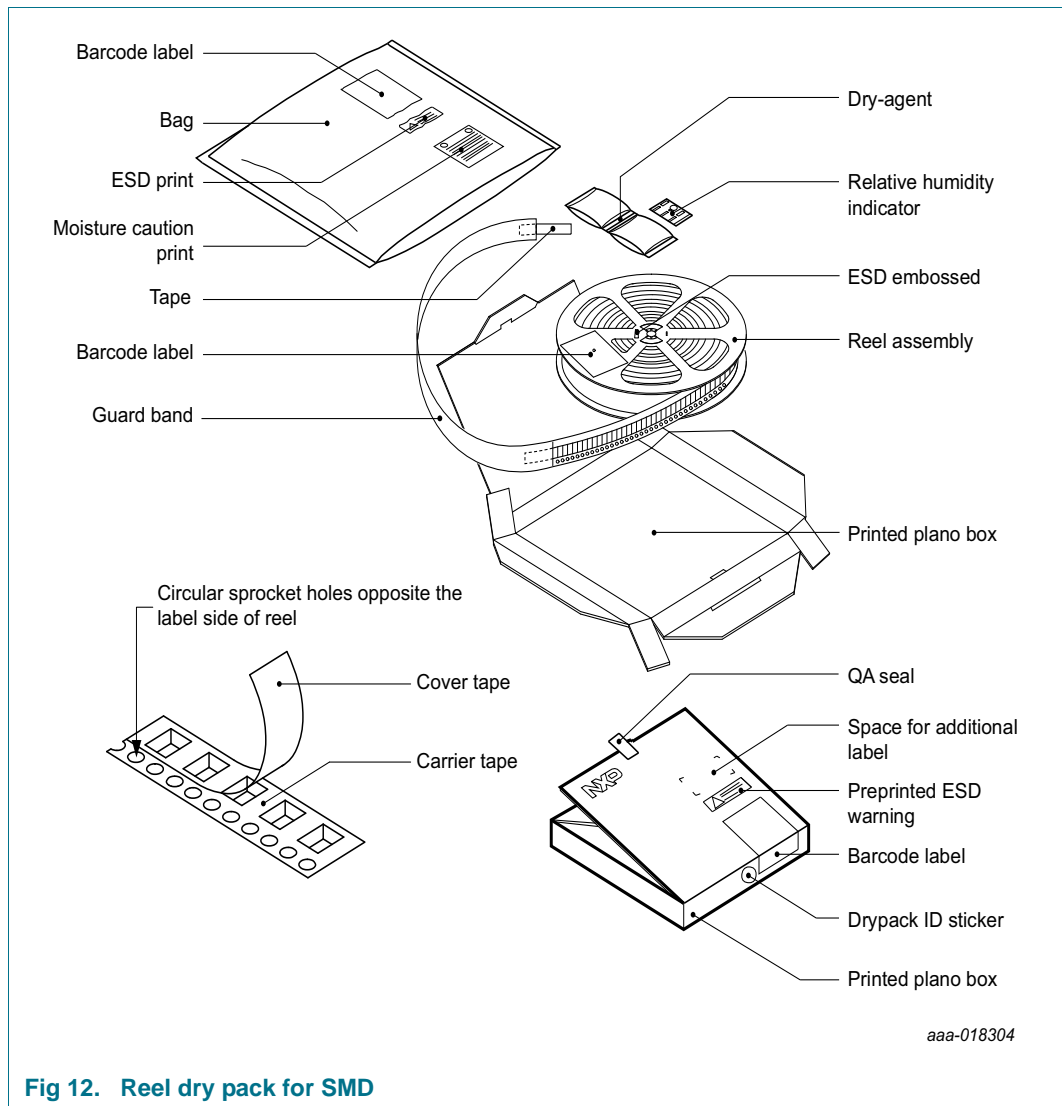

**Table 14. Dimensions and quantities**

Reel dimensions d × w (mm) [1]	SPQ/PQ (pcs)[2]	Reels per box	Outer box dimensions l × w × h (mm)
330 × 12	6000	1	342 × 338 × 27

[1] d = reel diameter; w = tape width.

[2] Packing quantity dependent on specific product type.

View ordering and availability details at [NXP order portal](#), or contact your local NXP representative.

**13.1.2 Product orientation**

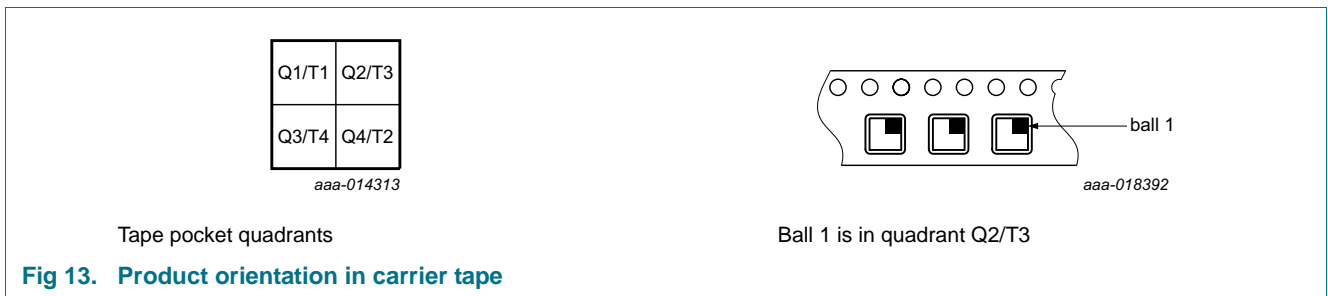

**Fig 13. Product orientation in carrier tape**

**13.1.3 Carrier tape dimensions**

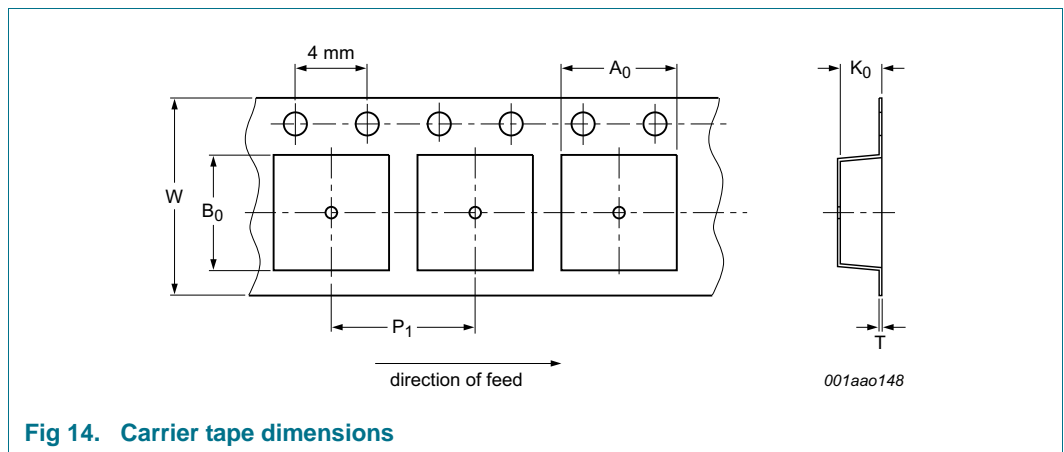

**Fig 14. Carrier tape dimensions**

**Table 15. Carrier tape dimensions**

In accordance with IEC 60286-3.

A <sub>0</sub> (mm)	B <sub>0</sub> (mm)	K <sub>0</sub> (mm)	T (mm)	P <sub>1</sub> (mm)	W (mm)
4.30 ± 0.10	4.30 ± 0.10	1.10 ± 0.10	0.30 ± 0.05	8.0 ± 0.10	12 ± 0.30

13.1.4 Reel dimensions

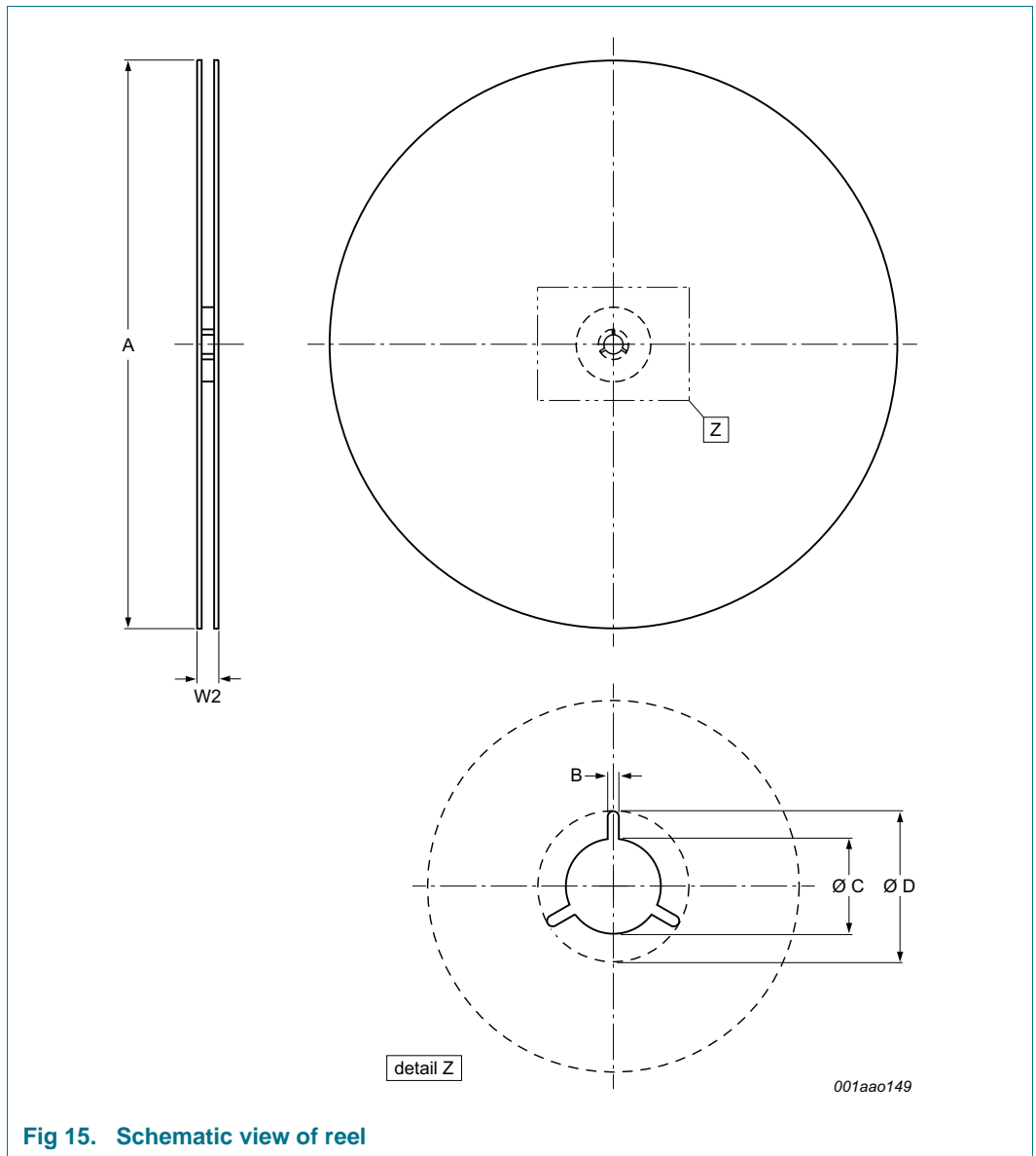

Fig 15. Schematic view of reel

Table 16. Reel dimensions  
In accordance with IEC 60286-3.

A [nom] (mm)	W2 [max] (mm)	B [min] (mm)	C [min] (mm)	D [min] (mm)
330	18.4	1.5	12.8	20.2

13.1.5 Barcode label

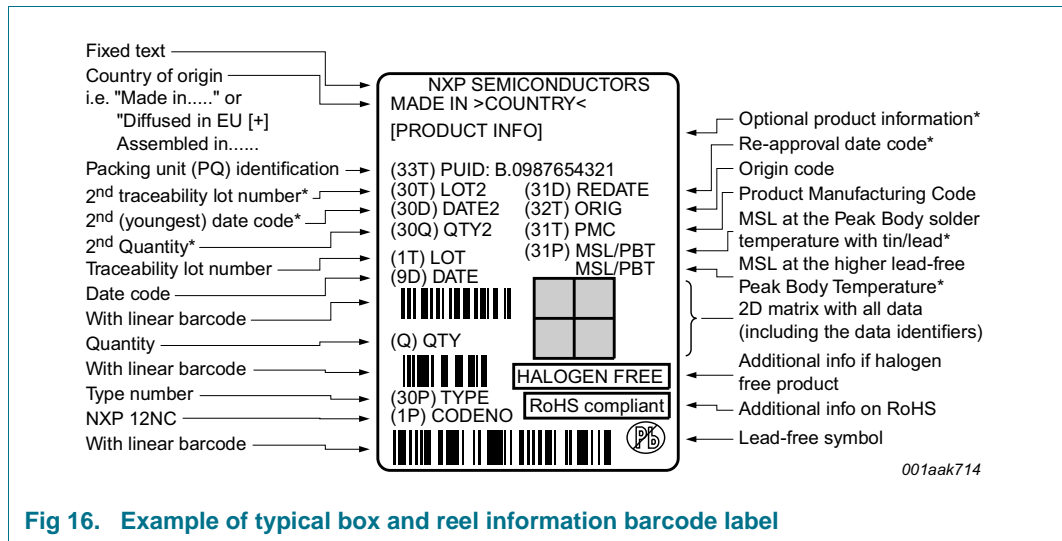

Table 17. Barcode label dimensions

Box barcode label l × w (mm)	Reel barcode label l × w (mm)
100 × 75	100 × 75

14. Soldering of SMD packages

This text provides a very brief insight into a complex technology. A more in-depth account of soldering ICs can be found in Application Note AN10365 “Surface mount reflow soldering description”.

14.1 Introduction to soldering

Soldering is one of the most common methods through which packages are attached to Printed Circuit Boards (PCBs), to form electrical circuits. The soldered joint provides both the mechanical and the electrical connection. There is no single soldering method that is ideal for all IC packages. Wave soldering is often preferred when through-hole and Surface Mount Devices (SMDs) are mixed on one printed wiring board; however, it is not suitable for fine pitch SMDs. Reflow soldering is ideal for the small pitches and high densities that come with increased miniaturization.

14.2 Wave and reflow soldering

Wave soldering is a joining technology in which the joints are made by solder coming from a standing wave of liquid solder. The wave soldering process is suitable for the following:

- Through-hole components
- Leaded or leadless SMDs, which are glued to the surface of the printed circuit board

Not all SMDs can be wave soldered. Packages with solder balls, and some leadless packages which have solder lands underneath the body, cannot be wave soldered. Also, leaded SMDs with leads having a pitch smaller than ~0.6 mm cannot be wave soldered, due to an increased probability of bridging.

The reflow soldering process involves applying solder paste to a board, followed by component placement and exposure to a temperature profile. Leaded packages, packages with solder balls, and leadless packages are all reflow solderable.

Key characteristics in both wave and reflow soldering are:

- Board specifications, including the board finish, solder masks and vias
- Package footprints, including solder thieves and orientation
- The moisture sensitivity level of the packages
- Package placement
- Inspection and repair
- Lead-free soldering versus SnPb soldering

### 14.3 Wave soldering

Key characteristics in wave soldering are:

- Process issues, such as application of adhesive and flux, clinching of leads, board transport, the solder wave parameters, and the time during which components are exposed to the wave
- Solder bath specifications, including temperature and impurities

### 14.4 Reflow soldering

Key characteristics in reflow soldering are:

- Lead-free versus SnPb soldering; note that a lead-free reflow process usually leads to higher minimum peak temperatures (see [Figure 17](#)) than a SnPb process, thus reducing the process window
- Solder paste printing issues including smearing, release, and adjusting the process window for a mix of large and small components on one board
- Reflow temperature profile; this profile includes preheat, reflow (in which the board is heated to the peak temperature) and cooling down. It is imperative that the peak temperature is high enough for the solder to make reliable solder joints (a solder paste characteristic). In addition, the peak temperature must be low enough that the packages and/or boards are not damaged. The peak temperature of the package depends on package thickness and volume and is classified in accordance with [Table 18](#) and [19](#)

**Table 18. SnPb eutectic process (from J-STD-020D)**

Package thickness (mm)	Package reflow temperature (°C)	
	Volume (mm <sup>3</sup> )	
	< 350	≥ 350
< 2.5	235	220
≥ 2.5	220	220

**Table 19. Lead-free process (from J-STD-020D)**

Package thickness (mm)	Package reflow temperature (°C)		
	Volume (mm <sup>3</sup> )		
	< 350	350 to 2000	> 2000
< 1.6	260	260	260
1.6 to 2.5	260	250	245
> 2.5	250	245	245

Moisture sensitivity precautions, as indicated on the packing, must be respected at all times.

Studies have shown that small packages reach higher temperatures during reflow soldering, see [Figure 17](#).

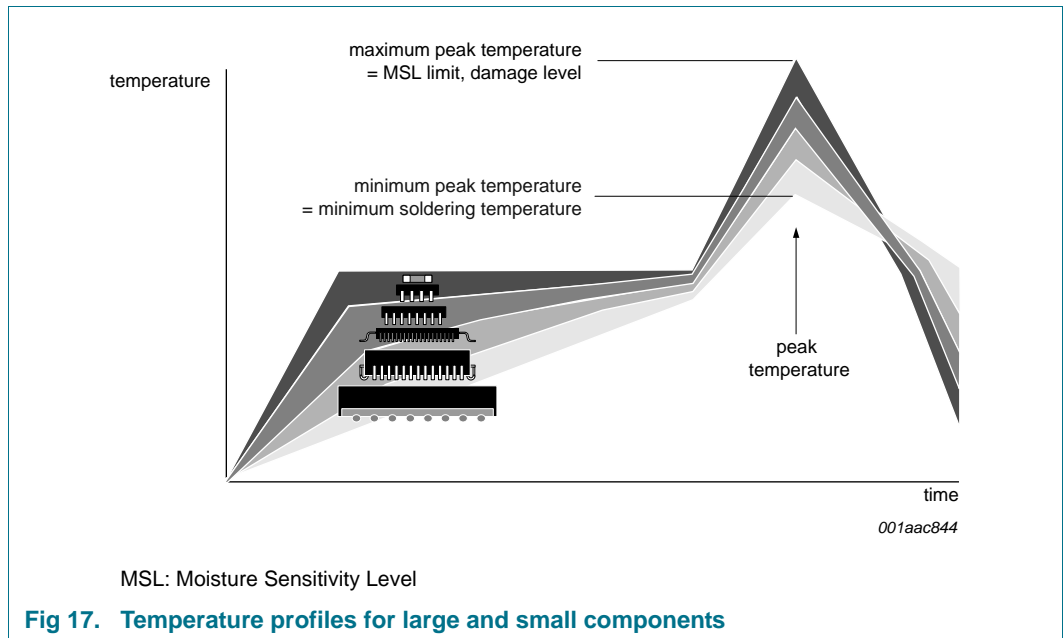

For further information on temperature profiles, refer to Application Note *AN10365 "Surface mount reflow soldering description"*.

15. Soldering: PCB footprints

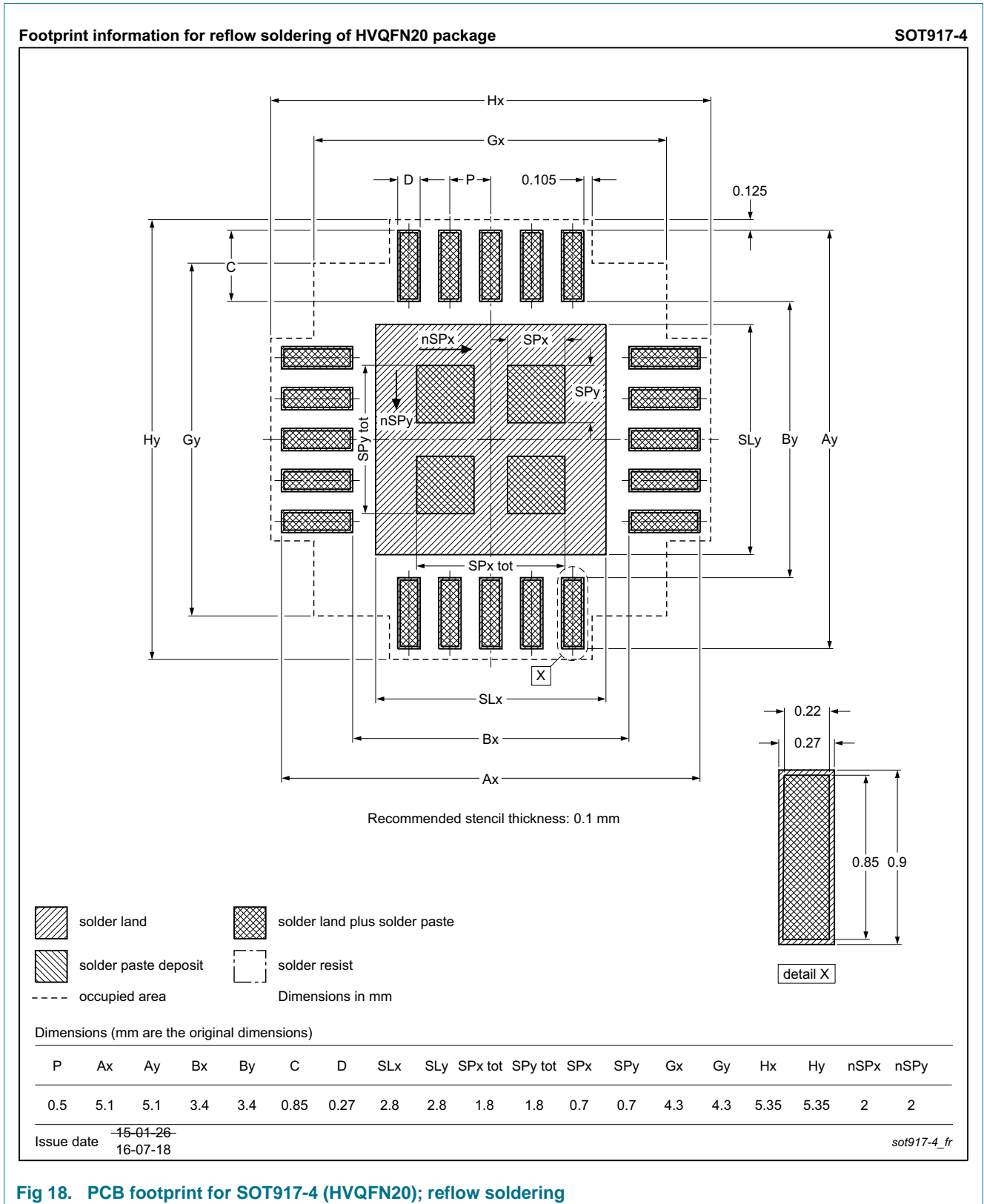

Fig 18. PCB footprint for SOT917-4 (HVQFN20); reflow soldering

## 16. Abbreviations

Table 20. Abbreviations

Acronym	Description
AP	Application Processor
ASIC	Application Specific Integrated Circuit
CDM	Charged Device Model, an ESD standard
CPU	Central Processing Unit
DBP	Dead Battery Provisioning
DFP	Downstream Facing Port
DRP	Dual Role Port
EC	Embedded Controller
FS	USB Full Speed signaling
HBM	Human Body Model, an ESD standard
HS	USB High Speed signaling
LDO	Low Drop-Out regulator
LS	USB Low Speed signaling
MM	Machine Model, an ESD standard
OC	Over-Current condition
OCD	Over-Current Detection
PCH	Platform Controller Hub
PD	Power Delivery specification
PMIC	Power Management IC
POR	Power ON Reset
SS	USB3.0 Super Speed Signaling
UFP	Upstream Facing Port
USB	Universal Serial Bus

## 17. References

- [1] USB Power Delivery Specification Revision 2.0 Version 1.09 April 2015
- [2] USB Type-C Cable and Connector Specification Revision 1.1, April 2015
- [3] AN11661 NXP USB Type-C PD Controller Application Programming Guide
- [4] UM10204, "I<sup>2</sup>C-bus specification and user manual"; NXP Semiconductors, Revision 03 June 19, 2007

## 18. Revision history

Table 21. Revision history

Document ID	Release date	Data sheet status	Change notice	Supersedes
PTN5100D v.1	20160802	Product data sheet	-	-

## 19. Legal information

### 19.1 Data sheet status

Document status <sup>[1][2]</sup>	Product status <sup>[3]</sup>	Definition
Objective [short] data sheet	Development	This document contains data from the objective specification for product development.
Preliminary [short] data sheet	Qualification	This document contains data from the preliminary specification.
Product [short] data sheet	Production	This document contains the product specification.

[1] Please consult the most recently issued document before initiating or completing a design.

[2] The term 'short data sheet' is explained in section "Definitions".

[3] The product status of device(s) described in this document may have changed since this document was published and may differ in case of multiple devices. The latest product status information is available on the Internet at URL <http://www.nxp.com>.

### 19.2 Definitions

**Draft** — The document is a draft version only. The content is still under internal review and subject to formal approval, which may result in modifications or additions. NXP Semiconductors does not give any representations or warranties as to the accuracy or completeness of information included herein and shall have no liability for the consequences of use of such information.

**Short data sheet** — A short data sheet is an extract from a full data sheet with the same product type number(s) and title. A short data sheet is intended for quick reference only and should not be relied upon to contain detailed and full information. For detailed and full information see the relevant full data sheet, which is available on request via the local NXP Semiconductors sales office. In case of any inconsistency or conflict with the short data sheet, the full data sheet shall prevail.

**Product specification** — The information and data provided in a Product data sheet shall define the specification of the product as agreed between NXP Semiconductors and its customer, unless NXP Semiconductors and customer have explicitly agreed otherwise in writing. In no event however, shall an agreement be valid in which the NXP Semiconductors product is deemed to offer functions and qualities beyond those described in the Product data sheet.

### 19.3 Disclaimers

**Limited warranty and liability** — Information in this document is believed to be accurate and reliable. However, NXP Semiconductors does not give any representations or warranties, expressed or implied, as to the accuracy or completeness of such information and shall have no liability for the consequences of use of such information. NXP Semiconductors takes no responsibility for the content in this document if provided by an information source outside of NXP Semiconductors.

In no event shall NXP Semiconductors be liable for any indirect, incidental, punitive, special or consequential damages (including - without limitation - lost profits, lost savings, business interruption, costs related to the removal or replacement of any products or rework charges) whether or not such damages are based on tort (including negligence), warranty, breach of contract or any other legal theory.

Notwithstanding any damages that customer might incur for any reason whatsoever, NXP Semiconductors' aggregate and cumulative liability towards customer for the products described herein shall be limited in accordance with the *Terms and conditions of commercial sale* of NXP Semiconductors.

**Right to make changes** — NXP Semiconductors reserves the right to make changes to information published in this document, including without limitation specifications and product descriptions, at any time and without notice. This document supersedes and replaces all information supplied prior to the publication hereof.

**Suitability for use** — NXP Semiconductors products are not designed, authorized or warranted to be suitable for use in life support, life-critical or safety-critical systems or equipment, nor in applications where failure or malfunction of an NXP Semiconductors product can reasonably be expected to result in personal injury, death or severe property or environmental damage. NXP Semiconductors and its suppliers accept no liability for inclusion and/or use of NXP Semiconductors products in such equipment or applications and therefore such inclusion and/or use is at the customer's own risk.

**Applications** — Applications that are described herein for any of these products are for illustrative purposes only. NXP Semiconductors makes no representation or warranty that such applications will be suitable for the specified use without further testing or modification.

Customers are responsible for the design and operation of their applications and products using NXP Semiconductors products, and NXP Semiconductors accepts no liability for any assistance with applications or customer product design. It is customer's sole responsibility to determine whether the NXP Semiconductors product is suitable and fit for the customer's applications and products planned, as well as for the planned application and use of customer's third party customer(s). Customers should provide appropriate design and operating safeguards to minimize the risks associated with their applications and products.

NXP Semiconductors does not accept any liability related to any default, damage, costs or problem which is based on any weakness or default in the customer's applications or products, or the application or use by customer's third party customer(s). Customer is responsible for doing all necessary testing for the customer's applications and products using NXP Semiconductors products in order to avoid a default of the applications and the products or of the application or use by customer's third party customer(s). NXP does not accept any liability in this respect.

**Limiting values** — Stress above one or more limiting values (as defined in the Absolute Maximum Ratings System of IEC 60134) will cause permanent damage to the device. Limiting values are stress ratings only and (proper) operation of the device at these or any other conditions above those given in the Recommended operating conditions section (if present) or the Characteristics sections of this document is not warranted. Constant or repeated exposure to limiting values will permanently and irreversibly affect the quality and reliability of the device.

**Terms and conditions of commercial sale** — NXP Semiconductors products are sold subject to the general terms and conditions of commercial sale, as published at <http://www.nxp.com/profile/terms>, unless otherwise agreed in a valid written individual agreement. In case an individual agreement is concluded only the terms and conditions of the respective agreement shall apply. NXP Semiconductors hereby expressly objects to applying the customer's general terms and conditions with regard to the purchase of NXP Semiconductors products by customer.

**No offer to sell or license** — Nothing in this document may be interpreted or construed as an offer to sell products that is open for acceptance or the grant, conveyance or implication of any license under any copyrights, patents or other industrial or intellectual property rights.

**Export control** — This document as well as the item(s) described herein may be subject to export control regulations. Export might require a prior authorization from competent authorities.

**Quick reference data** — The Quick reference data is an extract of the product data given in the Limiting values and Characteristics sections of this document, and as such is not complete, exhaustive or legally binding.

**Non-automotive qualified products** — Unless this data sheet expressly states that this specific NXP Semiconductors product is automotive qualified, the product is not suitable for automotive use. It is neither qualified nor tested in accordance with automotive testing or application requirements. NXP Semiconductors accepts no liability for inclusion and/or use of non-automotive qualified products in automotive equipment or applications.

In the event that customer uses the product for design-in and use in automotive applications to automotive specifications and standards, customer (a) shall use the product without NXP Semiconductors' warranty of the

product for such automotive applications, use and specifications, and (b) whenever customer uses the product for automotive applications beyond NXP Semiconductors' specifications such use shall be solely at customer's own risk, and (c) customer fully indemnifies NXP Semiconductors for any liability, damages or failed product claims resulting from customer design and use of the product for automotive applications beyond NXP Semiconductors' standard warranty and NXP Semiconductors' product specifications.

**Translations** — A non-English (translated) version of a document is for reference only. The English version shall prevail in case of any discrepancy between the translated and English versions.

## 19.4 Trademarks

Notice: All referenced brands, product names, service names and trademarks are the property of their respective owners.

## 20. Contact information

For more information, please visit: <http://www.nxp.com>

For sales office addresses, please send an email to: [salesaddresses@nxp.com](mailto:salesaddresses@nxp.com)

## 21. Contents

<b>1</b>	<b>General description</b> . . . . .	<b>1</b>	13.1	SOT917-4: HVQFN20; Reel dry pack, SMD, 13"; Q2/T3 turned product orientation; Orderable part number ending ,528 or MP; Ordering code (12NC) ending 528 . . . . .	26
<b>2</b>	<b>Features and benefits</b> . . . . .	<b>1</b>	13.1.1	Packing method . . . . .	26
2.1	USB PD and Type-C Features . . . . .	1	13.1.2	Product orientation . . . . .	27
2.2	System protection features . . . . .	2	13.1.3	Carrier tape dimensions . . . . .	27
2.3	General . . . . .	2	13.1.4	Reel dimensions . . . . .	28
<b>3</b>	<b>Applications</b> . . . . .	<b>2</b>	13.1.5	Barcode label . . . . .	29
<b>4</b>	<b>Ordering information</b> . . . . .	<b>2</b>	<b>14</b>	<b>Soldering of SMD packages</b> . . . . .	<b>30</b>
4.1	Ordering options . . . . .	3	14.1	Introduction to soldering . . . . .	30
<b>5</b>	<b>Block diagram</b> . . . . .	<b>3</b>	14.2	Wave and reflow soldering . . . . .	30
<b>6</b>	<b>Pinning information</b> . . . . .	<b>4</b>	14.3	Wave soldering . . . . .	30
6.1	Pinning . . . . .	4	14.4	Reflow soldering . . . . .	31
6.2	Pin description . . . . .	5	<b>15</b>	<b>Soldering: PCB footprints</b> . . . . .	<b>33</b>
<b>7</b>	<b>Functional description</b> . . . . .	<b>7</b>	<b>16</b>	<b>Abbreviations</b> . . . . .	<b>34</b>
7.1	Type-C Configuration Channel functional block . . . . .	7	<b>17</b>	<b>References</b> . . . . .	<b>34</b>
7.2	USB Power Delivery Function . . . . .	7	<b>18</b>	<b>Revision history</b> . . . . .	<b>35</b>
7.3	Power FET control . . . . .	9	<b>19</b>	<b>Legal information</b> . . . . .	<b>36</b>
7.4	MCU interface and control . . . . .	10	19.1	Data sheet status . . . . .	36
7.4.1	I <sup>2</sup> C-bus interface . . . . .	10	19.2	Definitions . . . . .	36
7.4.1.1	I <sup>2</sup> C writes . . . . .	10	19.3	Disclaimers . . . . .	36
7.4.1.2	I <sup>2</sup> C reads . . . . .	10	19.4	Trademarks . . . . .	37
7.4.1.3	I <sup>2</sup> C address auto-incrementing . . . . .	11	<b>20</b>	<b>Contact information</b> . . . . .	<b>37</b>
7.4.2	SPI interface . . . . .	11	<b>21</b>	<b>Contents</b> . . . . .	<b>38</b>
7.4.3	Register interface . . . . .	11			
7.4.4	Relevant Interface pins - SLV_ADDR, SPI_CLK_I2C_SCL, SPI_MOSI_I2C_SDA, SPI_CS, SPI_MISO, INT_N . . . . .	11			
7.5	Power supplies . . . . .	11			
<b>8</b>	<b>PTN5100D - Use case view</b> . . . . .	<b>12</b>			
8.1	System use case illustration . . . . .	13			
8.1.1	Type-C cable adapter with PTN5100D . . . . .	13			
8.1.1.1	Application description . . . . .	13			
<b>9</b>	<b>Limiting values</b> . . . . .	<b>14</b>			
<b>10</b>	<b>Recommended operating conditions</b> . . . . .	<b>15</b>			
<b>11</b>	<b>Characteristics</b> . . . . .	<b>16</b>			
11.1	Device characteristics . . . . .	16			
11.2	USB PD and Type-C characteristics . . . . .	17			
11.3	Power AC/DC characteristics . . . . .	19			
11.4	I <sup>2</sup> C characteristics . . . . .	19			
11.5	SPI characteristics . . . . .	22			
11.6	CONTROL IO characteristics . . . . .	23			
<b>12</b>	<b>Package outline</b> . . . . .	<b>25</b>			
<b>13</b>	<b>Packing information</b> . . . . .	<b>26</b>			

Please be aware that important notices concerning this document and the product(s) described herein, have been included in section 'Legal information'.

© NXP Semiconductors N.V. 2016.

All rights reserved.

For more information, please visit: <http://www.nxp.com>



For sales office addresses, please send an email to: [salesaddresses@nxp.com](mailto:salesaddresses@nxp.com)

Date of release: 2 August 2016

Document identifier: PTN5100D

## Looking for pricing, stock, or lifecycle information?

Click below to explore more details on WIN SOURCE:

-  [View PTN5100DBSMP](#) on WIN SOURCE
-  [NXP / Nexperia](#) Information

## Optimize Your Supply Chain with WIN SOURCE Solutions

-  Global Sourcing Solution
-  Obsolete Management
-  Cost Control Management
-  Shortage Management
-  Alternative Solution
-  Excess Inventory Management