



**THE DATASHEET OF
AZ4580MTR-G1**



DUAL LOW NOISE OPERATIONAL AMPLIFIERS

AZ4580

General Description

The AZ4580 is a monolithic dual low noise operational amplifier. It is specifically designed for audio systems to improve tone control; it can also be used in pre-amplifier, industrial measurement tools and applications where gain and phase matched channels are mandatory.

The IC features internal frequency compensation, low noise, low distortion, high gain and high bandwidth. The AZ4580 can operate under dual power supply voltage up to $\pm 18V$ or single power supply up to 36V.

The AZ4580 is available in DIP-8, SOIC-8 and TSSOP-8 packages.

Features

- Large Signal Voltage Gain: 110dB Typical
- Low Input Noise Voltage: $0.7\mu V_{RMS}$ (RIAA) Typical
- Wide Gain Bandwidth Product: 15MHz at 10KHz Typical
- Low Distortion: 0.0005% Typical
- Slew Rate: $7V/\mu s$ Typical

Applications

- Audio AC-3 Decoder System
- Audio Amplifier

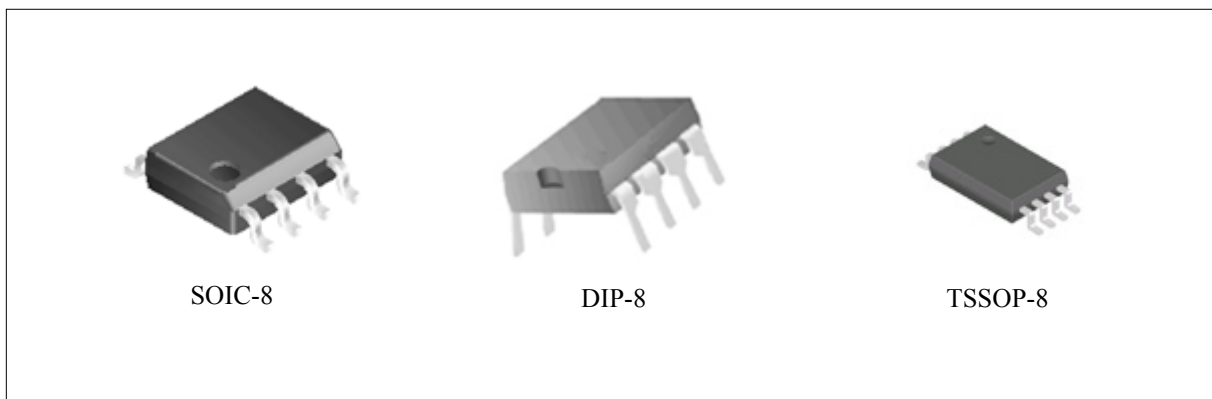

Figure 1. Package Types of AZ4580

Pin Configuration

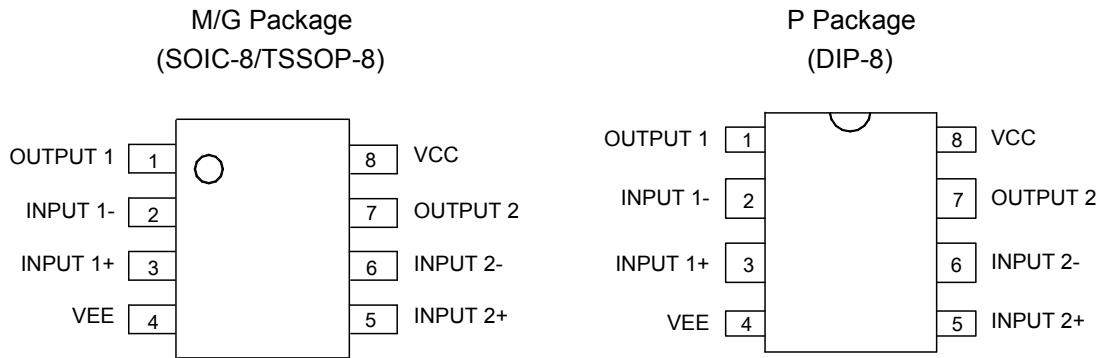

Figure 2. Pin Configuration of AZ4580

Pin Description

Pin No.	Function	Pin No.	Function	Pin No.	Function	Pin No.	Function
1	OUTPUT 1	2	INPUT 1-	3	INPUT 1+	4	VEE
5	INPUT 2+	6	INPUT 2-	7	OUTPUT 2	8	VCC

Functional Block Diagram

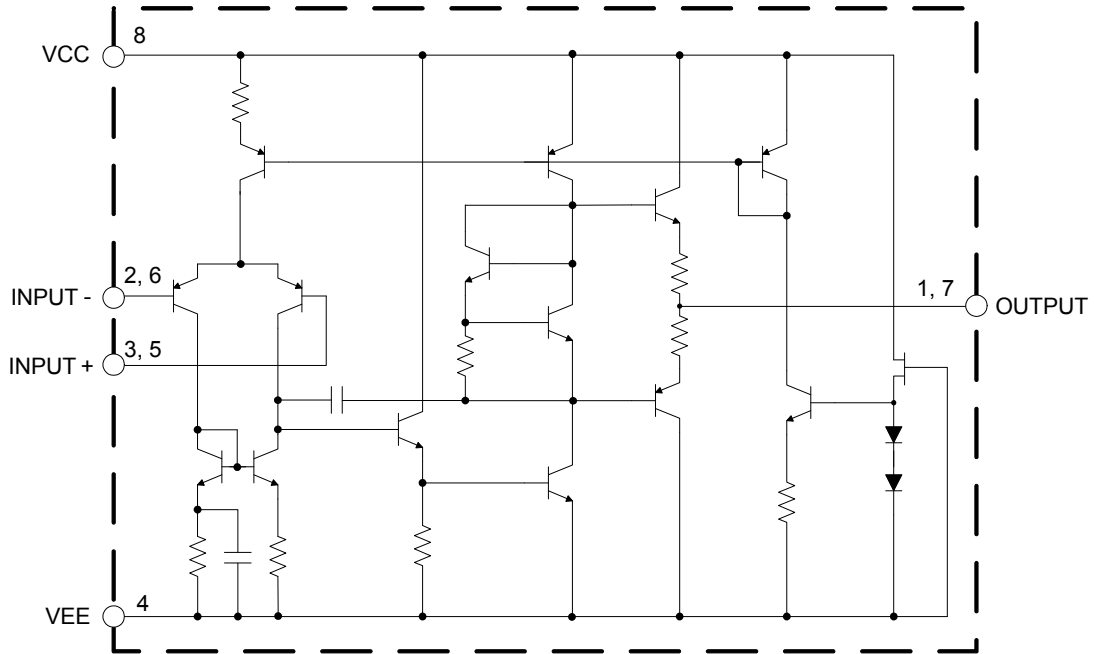
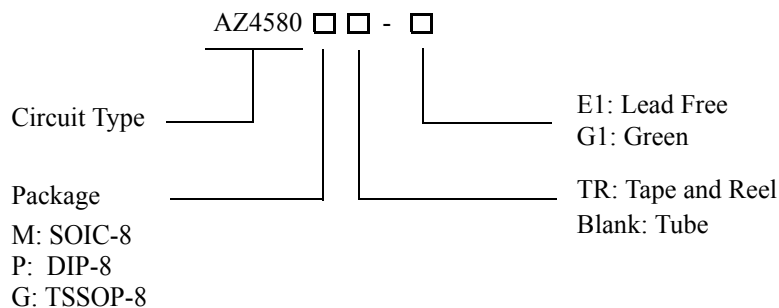

Figure 3. Representative Schematic Diagram of AZ4580 (Each Amplifier)



DUAL LOW NOISE OPERATIONAL AMPLIFIERS **AZ4580**

Ordering Information



Package	Temperature Range	Part Number		Marking ID		Packing Type
		Lead Free	Green	Lead Free	Green	
SOIC-8	-40 to 85°C	AZ4580M-E1	AZ4580M-G1	4580M-E1	4580M-G1	Tube
		AZ4580MTR-E1	AZ4580MTR-G1	4580M-E1	4580M-G1	Tape & Reel
DIP-8	-40 to 85°C	AZ4580P-E1	AZ4580P-G1	AZ4580P-E1	AZ4580P-G1	Tube
TSSOP-8	-40 to 85°C	AZ4580GTR-E1	AZ4580GTR-G1	EG80	GG80	Tape & Reel

BCD Semiconductor's Pb-free products, as designated with "E1" suffix in the part number, are RoHS compliant. Products with "G1" suffix are available in green packages.

**DUAL LOW NOISE OPERATIONAL AMPLIFIERS****AZ4580****Absolute Maximum Ratings (Note 1)**

Parameter	Smbol	Value		Unit
Power Supply Voltage	V_{CC}	+ 20		V
	V_{EE}	- 20		
Input Voltage	V_I	± 15		V
Differential Input Voltage	V_{ID}	± 30		V
Operating Junction Temperature	T_J	150		$^{\circ}\text{C}$
Storage Temperature Range	T_{STG}	-65 to 150		$^{\circ}\text{C}$
Lead Temperature (Soldering 10s)	T_L	260		$^{\circ}\text{C}$
Power Dissipation ($T_A=25^{\circ}\text{C}$)	P_D	TSSOP-8	400	mW
		SOIC-8	500	
		DIP-8	800	

Note 1: Stresses greater than those listed under "Absolute Maximum Ratings" may cause permanent damage to the device. These are stress ratings only, and functional operation of the device at these or any other conditions beyond those indicated under "Recommended Operating Conditions" is not implied. Exposure to "Absolute Maximum Ratings" for extended periods may affect device reliability.

Recommended Operating Conditions

Parameter	Min	Max	Unit
Supply Voltage	± 2	± 18	V
Operating Temperature Range	-40	85	$^{\circ}\text{C}$



DUAL LOW NOISE OPERATIONAL AMPLIFIERS

AZ4580

Electrical Characteristics

Operating Conditions: $V_{CC}=+15V$, $V_{EE}=-15V$, $T_A=25^{\circ}C$ unless otherwise specified.

Parameter	Conditions	Min	Typ	Max	Unit
Supply Current	no load		4	7	mA
Input Offset Voltage	$R_S \leq 10K\Omega$		0.5	3	mV
Input Offset Current	$V_{CM}=0V$		5	100	nA
Input Bias Current	$V_{CM}=0V$		150	500	nA
Input Common Mode Voltage Range		± 12	± 13.5		V
Common Mode Rejection Ratio	$V_{CM}=0V$ to $V_{CC}-1.5V$, $R_S \leq 10K\Omega$	80	110		dB
Large Signal Voltage Gain	$R_L=2K\Omega$, $V_O=\pm 10V$	90	110		dB
Power Supply Rejection Ratio	$R_S \leq 10K\Omega$	80	110		dB
Output Sink Current	$V-=1V$, $V+=0V$, $V_O=2V$		80		mA
Output Source Current	$V+=1V$, $V-=0V$, $V_O=2V$		45		mA
Slew Rate	$R_L \geq 2K\Omega$		7		V/ μ S
Gain Bandwidth Product	$R_L=2K\Omega$, $f=10KHz$		15		MHz
Total Harmonic Distortion	$A_V=20dB$, $V_O=5V$ $R_L=2K\Omega$, $f=1KHz$		0.0005		%
Equivalent Input Noise Voltage	RIAA $R_S=50\Omega$, 30KHz LPF		0.7		μV_{RMS}
Thermal Resistance (Junction to Case)	DIP-8		43		$^{\circ}C/W$
	SOIC-8		63		



Typical Performance Characteristics

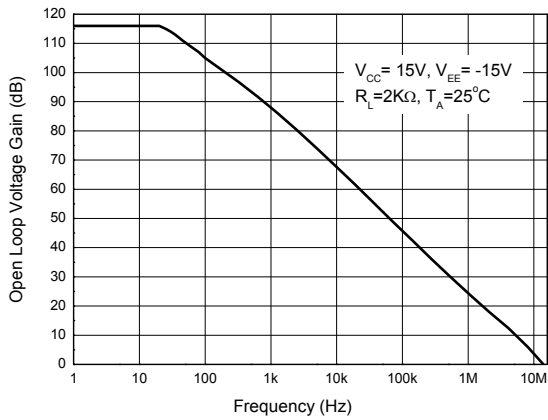

Figure 4. Open Loop Voltage Gain vs. Frequency

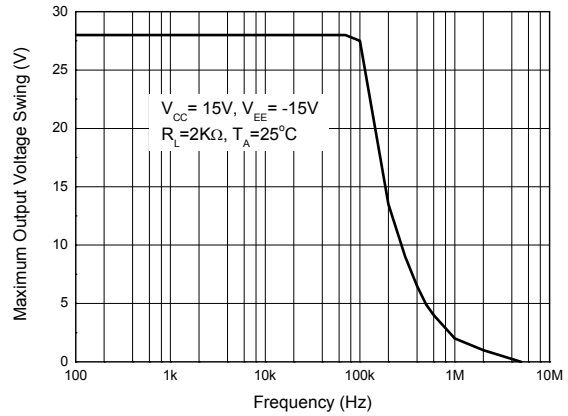

Figure 5. Maximum Output Voltage Swing vs. Frequency

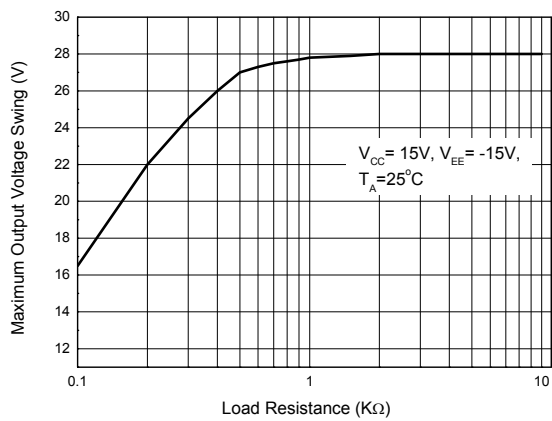

Figure 6. Maximum Output Voltage Swing vs. Load Resistance

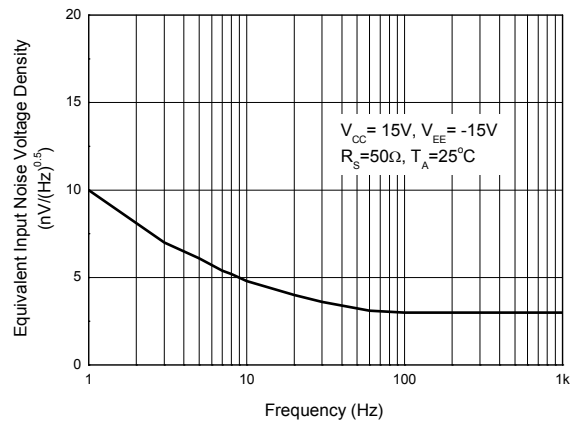

Figure 7. Equivalent Input Noise Voltage Density vs. Frequency

Typical Performance Characteristics (Continued)

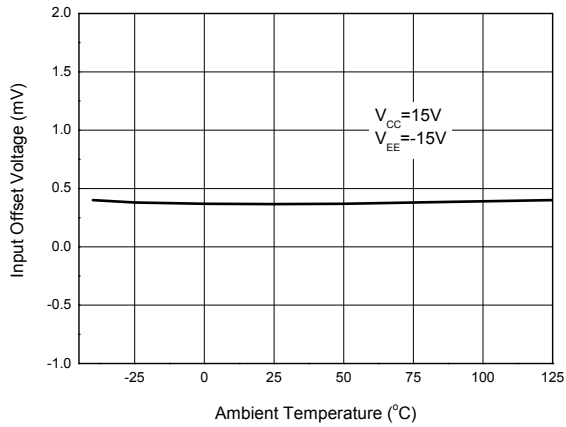

Figure 8. Input Offset Voltage vs. Temperature

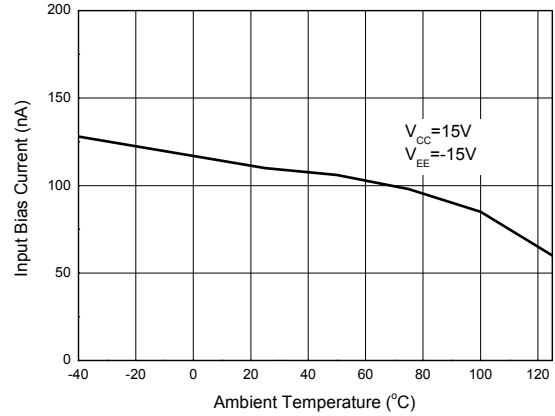

Figure 9. Input Bias Current vs. Temperature

Typical Applications

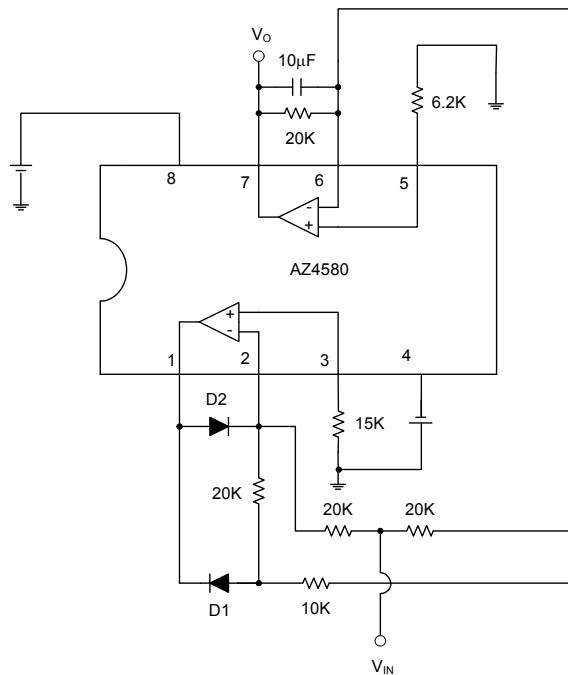

Figure 10. Application of AZ4580 in an AC/DC Converter

Typical Applications (Continued)

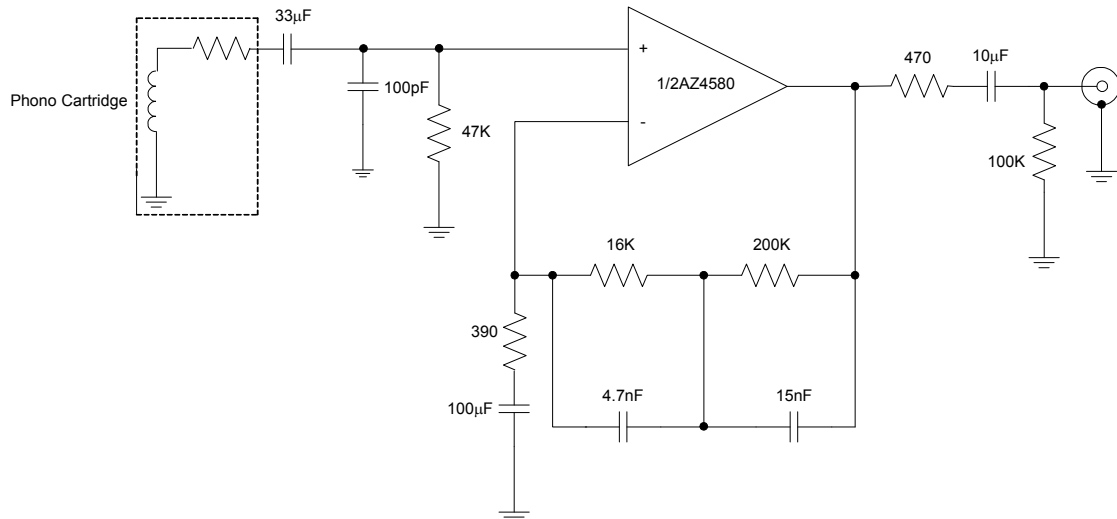

Figure 11. Application of AZ4580 in a RIAA Preamp

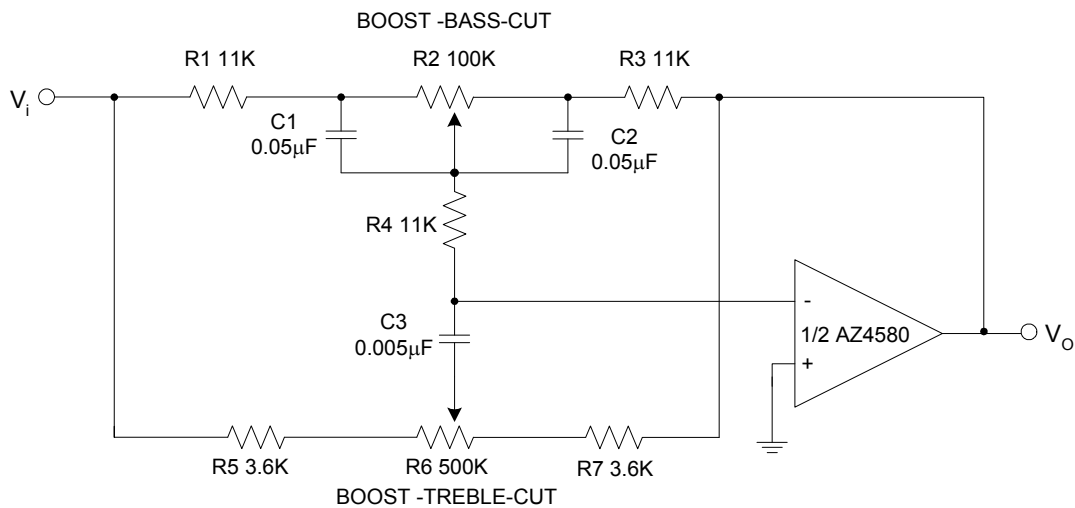

Figure 12. Application of AZ4580 in Tone Control



Mechanical Dimensions

DIP-8

Unit: mm(inch)

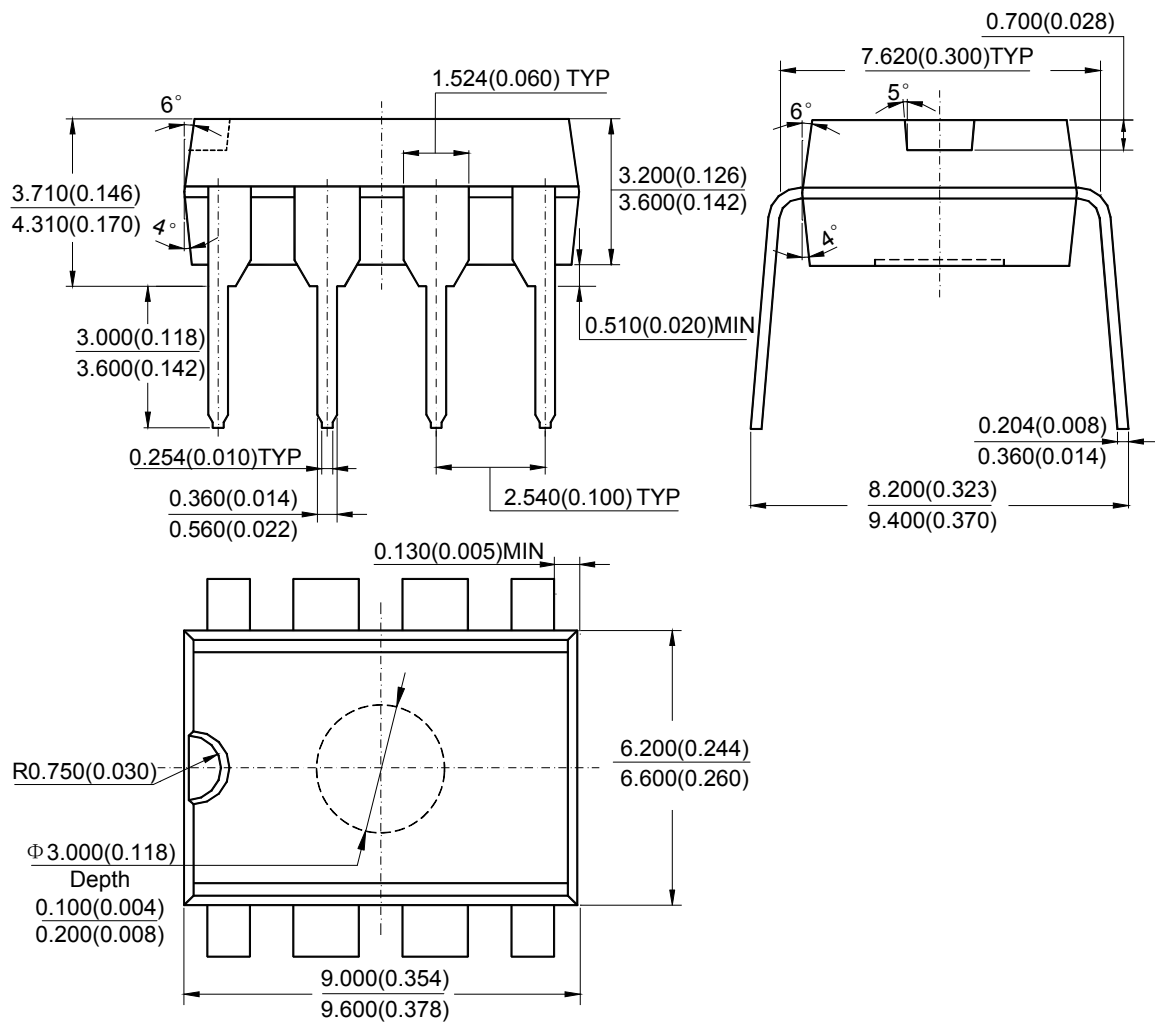

Note: Eject hole, oriented hole and mold mark is optional.



DUAL LOW NOISE OPERATIONAL AMPLIFIERS

AZ4580

Mechanical Dimensions (Continued)

SOIC-8

Unit: mm(inch)

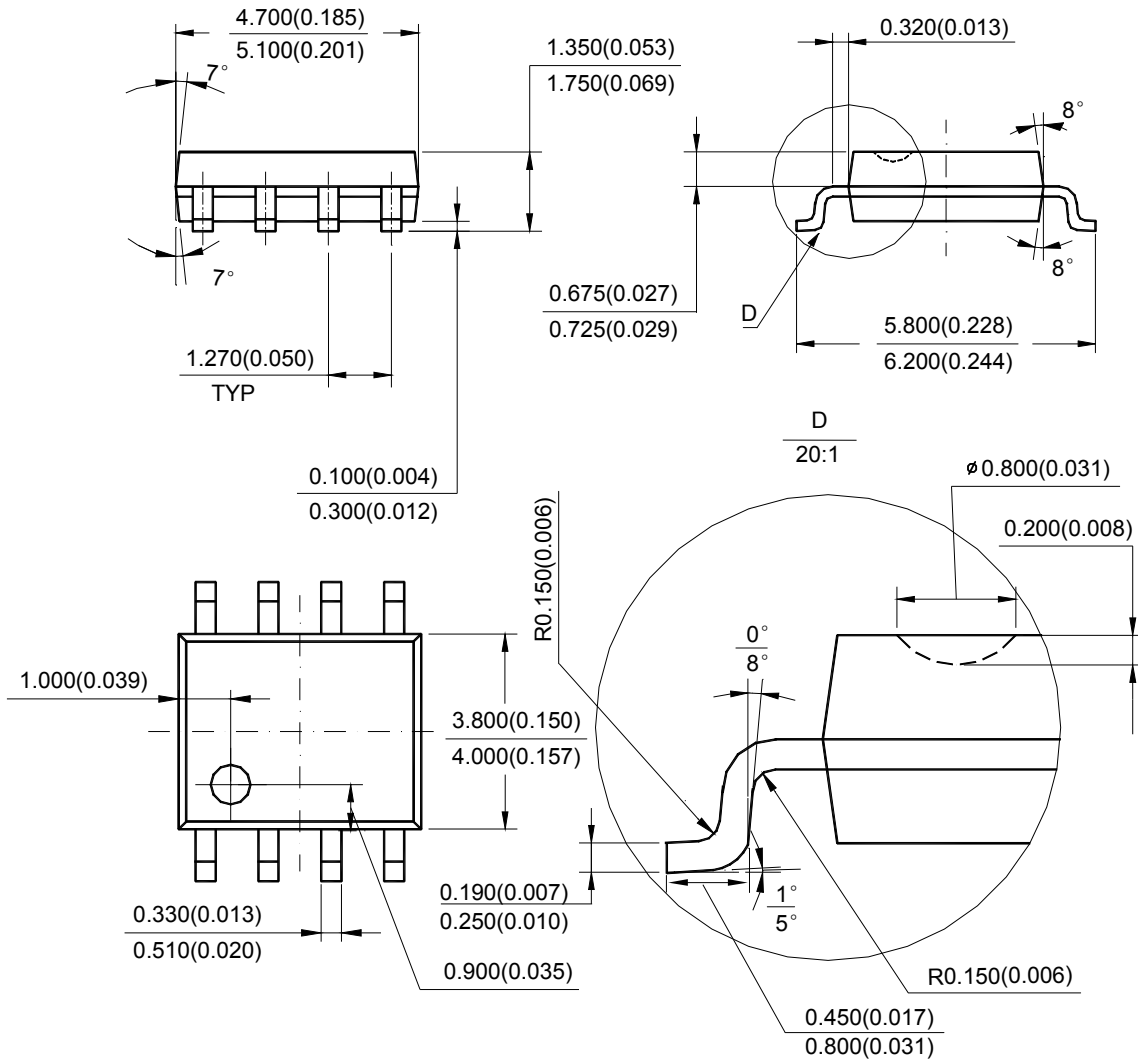

Note: Eject hole, oriented hole and mold mark is optional.



Mechanical Dimensions (Continued)

TSSOP-8

Unit: mm(inch)

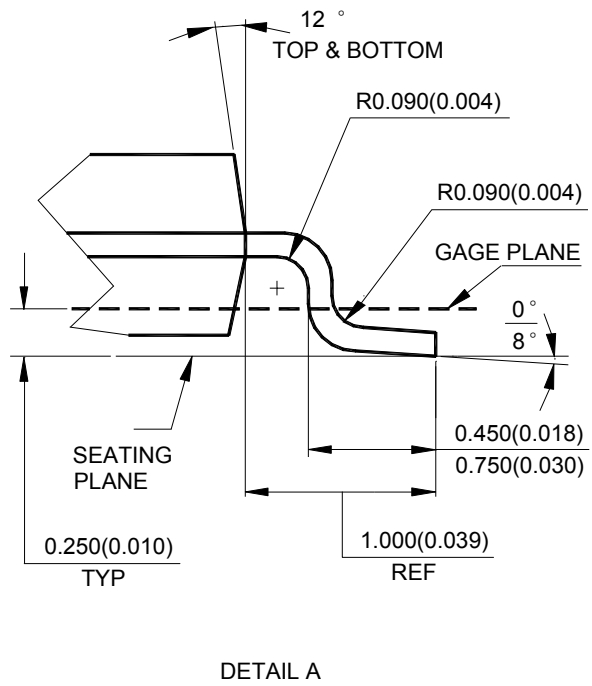
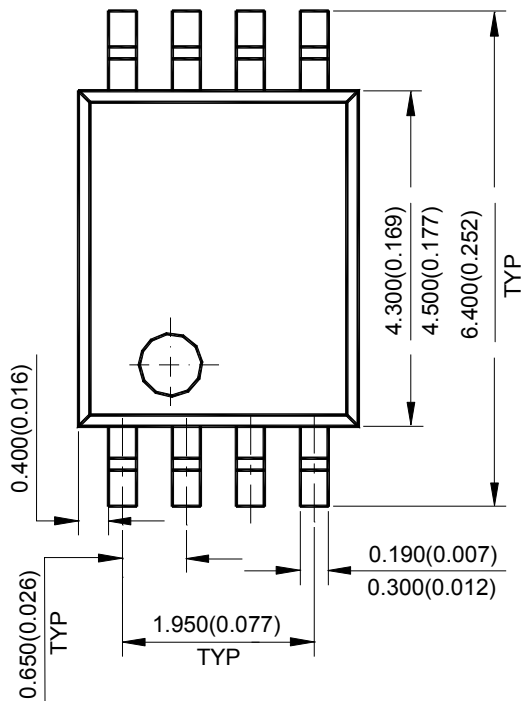
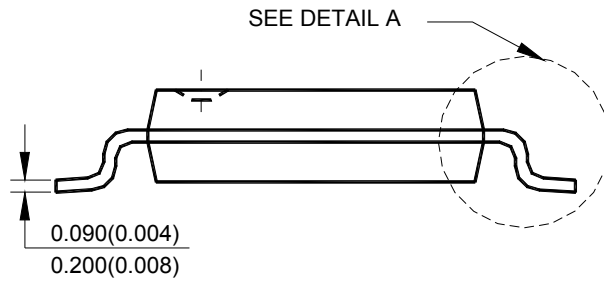
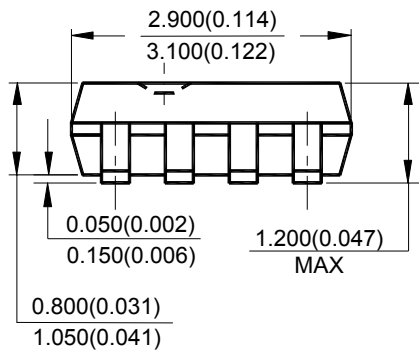

Note: Eject hole, oriented hole and mold mark is optional.



BCD Semiconductor Manufacturing Limited

<http://www.bcdsemi.com>

IMPORTANT NOTICE

BCD Semiconductor Manufacturing Limited reserves the right to make changes without further notice to any products or specifications herein. BCD Semiconductor Manufacturing Limited does not assume any responsibility for use of any its products for any particular purpose, nor does BCD Semiconductor Manufacturing Limited assume any liability arising out of the application or use of any its products or circuits. BCD Semiconductor Manufacturing Limited does not convey any license under its patent rights or other rights nor the rights of others.

MAIN SITE

- Headquarters

BCD Semiconductor Manufacturing Limited

No. 1600, Zi Xing Road, Shanghai ZiZhu Science-based Industrial Park, 200241, China
Tel: +86-21-24162266, Fax: +86-21-24162277

- Wafer Fab

Shanghai SIM-BCD Semiconductor Manufacturing Co., Ltd.

800 Yi Shan Road, Shanghai 200233, China
Tel: +86-21-6485 1491, Fax: +86-21-5450 0008

REGIONAL SALES OFFICE

Shenzhen Office

Shanghai SIM-BCD Semiconductor Manufacturing Co., Ltd., Shenzhen Office

Unit A Room 1203, Skyworth Bldg., Gaoxin Ave. 1.S., Nanshan District, Shenzhen, China
Tel: +86-755-8826 7951
Fax: +86-755-8826 7865

Taiwan Office

BCD Semiconductor (Taiwan) Company Limited

4F, 298-1, Rui Guang Road, Nei-Hu District, Taipei, Taiwan
Tel: +886-2-2656 2808
Fax: +886-2-2656 2806

USA Office

BCD Semiconductor Corp.

30920 Huntwood Ave. Hayward, CA 94544, USA
Tel : +1-510-324-2988
Fax: +1-510-324-2788

Looking for pricing, stock, or lifecycle information?

Click below to explore more details on WIN SOURCE:

-  [View AZ4580MTR-G1 on WIN SOURCE](#)
-  [Diodes Incorporated Information](#)

Optimize Your Supply Chain with WIN SOURCE Solutions

-  Global Sourcing Solution
-  Obsolete Management
-  Cost Control Management
-  Shortage Management
-  Alternative Solution
-  Excess Inventory Management