



THE DATASHEET OF UC2836D



High Efficiency Regulator Controller

FEATURES

- Complete Control for a High Current, Low Dropout, Linear Regulator
- Fixed 5V or Adjustable Output Voltage
- Accurate 2.5A Current Limiting with Foldback
- Internal Current Sense Resistor
- Remote Sense for Improved Load Regulation
- External Shutdown
- Under-Voltage Lockout and Reverse Voltage Protection
- Thermal Shutdown Protection
- 8 Pin Mini-Dip Package (Surface Mount also Available)

DESCRIPTION

The UC1835/6 families of linear controllers are optimized for the design of low cost, low dropout, linear regulators. Using an external pass element, dropout voltages of less than 0.5V are readily obtained. These devices contain a high gain error amplifier, a 250mA output driver, and a precision reference. In addition, current sense with foldback provides for a 2.5A peak output current dropping to less than 0.5A at short circuit.

These devices are available in fixed, 5V, (UC1835), or adjustable, (UC1836), versions. In the fixed 5 volt version, the only external parts required are an external pass element, an output capacitor, and a compensation capacitor. On the adjustable version the output voltage can be set anywhere from 2.5V to 35V with two external resistors.

Additional features of these devices include under-voltage lockout for predictable start-up, thermal shutdown and short circuit current limiting to protect the driver device. On the fixed voltage version, a reverse voltage comparator minimizes reverse load current in the event of a negative input to output differential.

BLOCK DIAGRAM

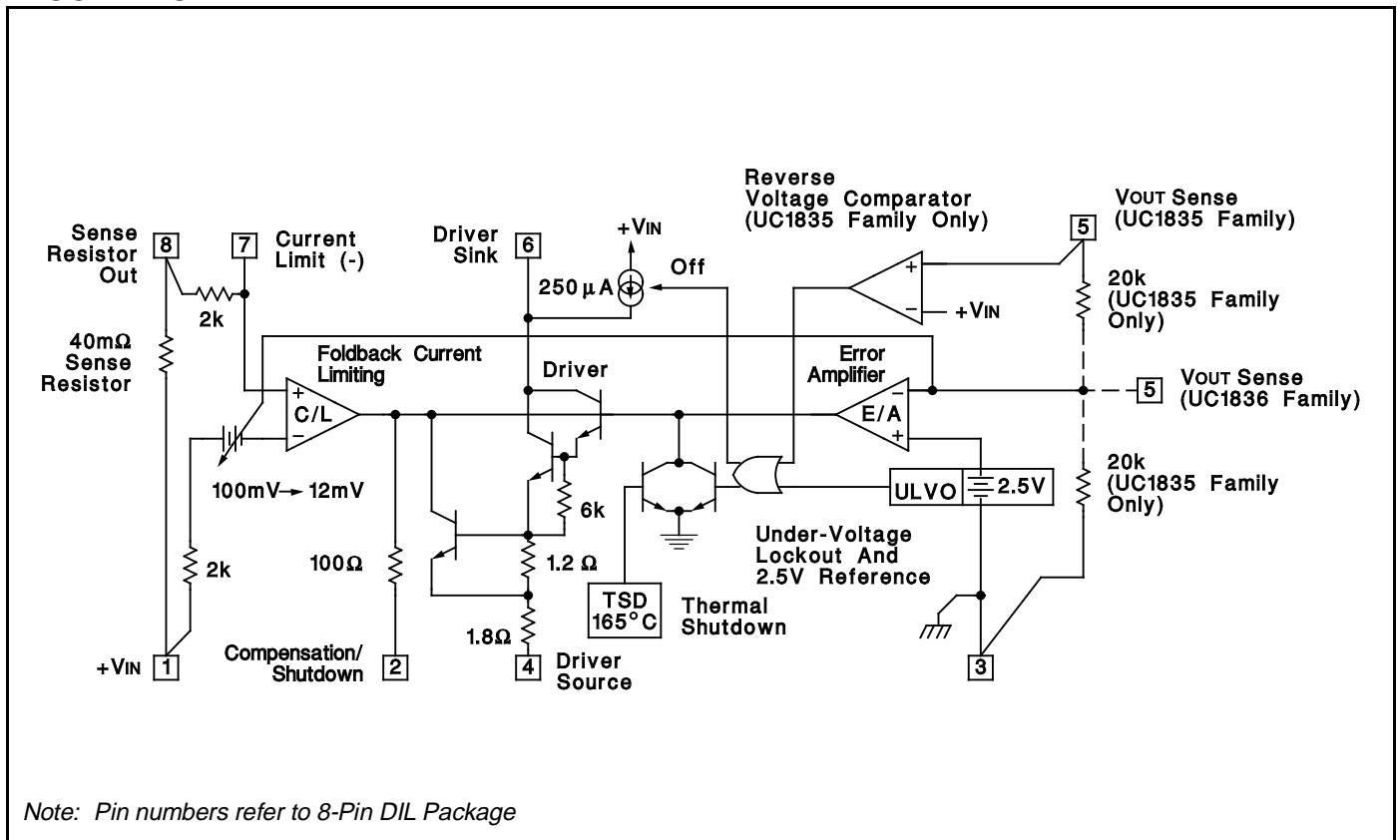

ABSOLUTE MAXIMUM RATINGS (Note 1)

Input Supply Voltage (+VIN) -1.0V to +40V
 Driver Output Current (Sink or Source) 600mA
 Driver Source to Sink Voltage +40V
 Maximum Current Through Sense Resistor. 4A
 VOUT Sense Input Voltage -3V to +40V
 Power Dissipation at TA = 25°C (Note 2) 1000mW
 Power Dissipation at Tc = 25°C (Note 2) 2000mW

Operating Junction Temperature -55°C to +150°C
 Storage Temperature -65°C to +150°C
 Lead Temperature (Soldering, 10 Seconds) 300°C

*Note 1: Voltages are referenced to ground, (Pin 3). Currents are positive into, negative out of, the specified terminals.
 Consult Packaging Section of Databook for thermal considerations and limitations of packages.*

CONNECTION DIAGRAMS

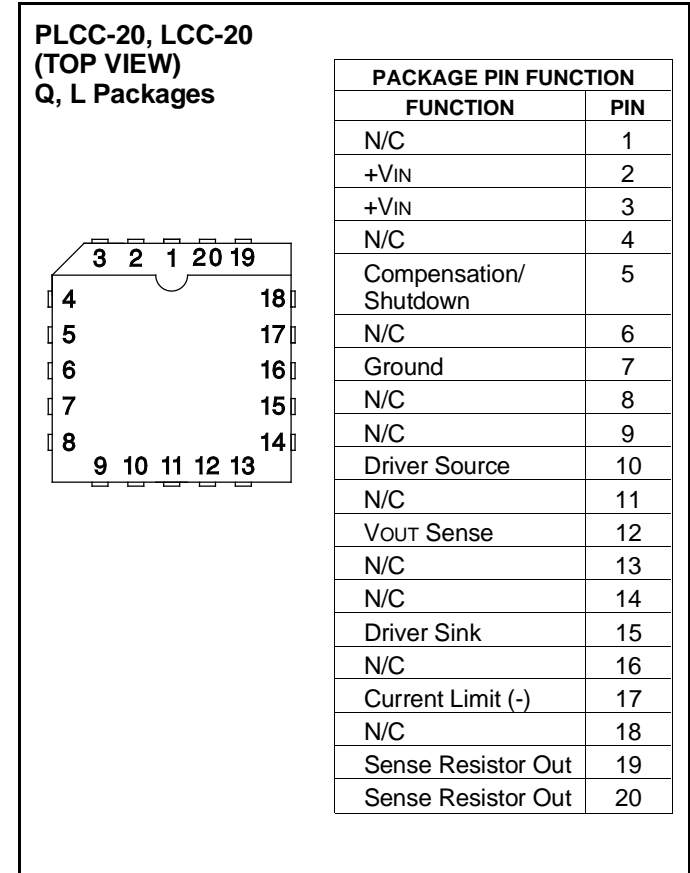
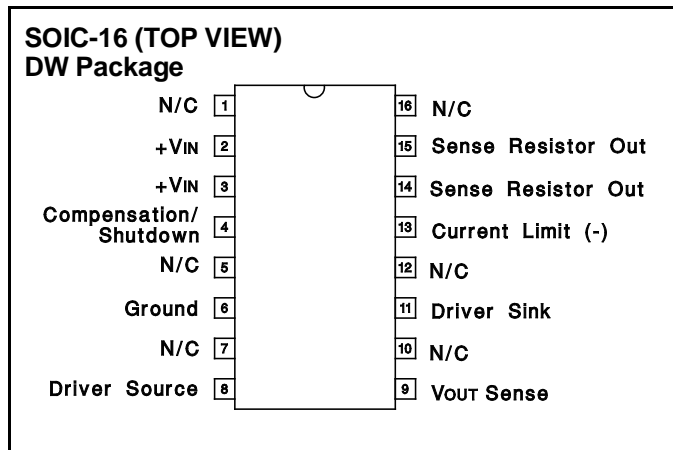
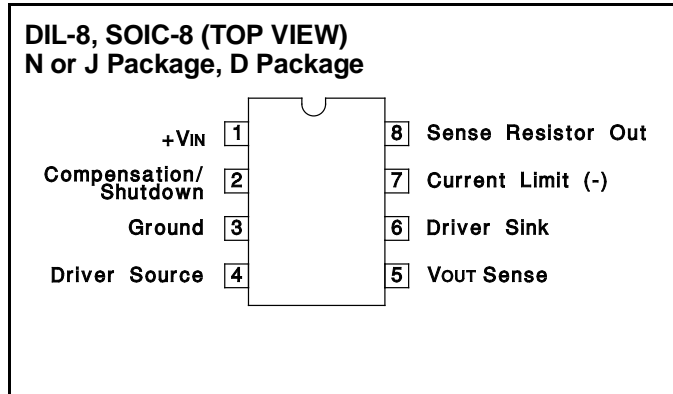

ELECTRICAL CHARACTERISTICS: Unless otherwise stated, specifications hold for TA = 0°C to +70°C for the UC3835/6, -25°C to +85°C for the UC2835/6, and -55°C to +125°C for the UC1835/6, +VIN = 6V, Driver Source= 0V, Driver Sink = 5V, TA = TJ.

PARAMETER	TEST CONDITIONS	MIN.	TYP.	MAX.	UNITS
Input Supply					
Supply Current	+VIN = 6V		2.75	4.0	mA
	+VIN = 40V		3.75	6.0	mA
UVLO Threshold	+VIN Low to High, VOUT Sense = 0V	3.9	4.4	4.9	V
Threshold Hysteresis			0.1	0.35	V
Reverse Current	+VIN = -1.0V, Driver Sink Open		6.0	20	mA
Regulating Voltage and Error Amplifier (UC1835 Family Only)					
Regulating Level at VOUT Sense (VREG)	Driver Current = 10mA, TJ = 25°C	4.94	5.0	5.06	V
	Over Temperature	4.9		5.1	V
Line Regulation	+VIN = 5.2V + 35V		15	40	mV
Load Regulation	Driver Current = 0 to 250mA		6.0	25	mV
Bias Current at VOUT Sense	VOUT Sense = 5.0V	75	125	210	µA
Error Amp Transconductance	±100µA at Compensation/Shutdown Pin	0.8	1.3	2.0	mS
Maximum Compensation Output Current	Sink or Source, Driver Source Open	90	200	260	µA

ELECTRICAL CHARACTERISTICS: Unless otherwise stated, specifications hold for $T_A = 0^\circ\text{C}$ to $+70^\circ\text{C}$ for the UC3835/6, -25°C to $+85^\circ\text{C}$ for the UC2835/6, and -55°C to $+125^\circ\text{C}$ for the UC1835/6, $+V_{IN} = 6\text{V}$, Driver Source = 0V , Driver Sink = 5V , $T_A = T_J$.

PARAMETER	TEST CONDITIONS	MIN.	TYP.	MAX.	UNITS
Regulating Voltage and Error Amplifier (UC1836 Family Only)					
Regulating Level at V_{OUT} Sense (V_{REG})	Driver Current = 10mA , $T_J = 25^\circ\text{C}$	2.47	2.5	2.53	V
	Over Temperature	2.45		2.55	V
Line Regulation	$+V_{IN} = 5.2\text{V}$ to 35V		6.0	20	mV
Load Regulation	Driver Current = 0 to 250mA		3.0	15	mV
Bias Current at V_{OUT} Sense	V_{OUT} Sense = 2.5V	-1.0	-0.2		μA
Error Amp Transconductance	$\pm 100\mu\text{A}$ at Compensation/Shutdown Pin	0.8	1.3	2.0	mS
Maximum Compensation Output Current	Sink or Source, Driver Source Open	90	200	260	μA
Driver					
Maximum Current		250	500		mA
Saturation Voltage	Driver Current = 250mA , Driver Sink		2.0	2.8	V
Pull-Up Current at Driver Sink	Compensation/Shutdown = 0.45V	140	250	300	μA
Driver Sink Leakage	In UVLO			10	μA
	In Reverse Voltage (UC1835 Family Only)			10	μA
Thermal Shutdown			165		$^\circ\text{C}$
Foldback Current Limit					
Current Limit Levels at Sense Resistor Out	V_{OUT} Sense = $(0.99) V_{REG}$	2.2	2.5	2.8	A
	V_{OUT} Sense = $(0.5) V_{REG}$	1.3	1.5	1.7	A
	V_{OUT} Sense = 0V	0.25	0.4	0.55	A
Current Limit Amp Transconductance	$\pm 100\mu\text{A}$ at Compensation/Shutdown, V_{OUT} Sense = $(0.9) V_{REG}$	12	24	42	mS
Limiting Voltage at Current Limit (-) (Note 2)	V_{OUT} Sense = $(0.9) V_{REG}$ Volts Below $+V_{IN}$, $T_J = 25^\circ\text{C}$	80	100	140	mV
Sense Resistor Value (Note 3)	V_{OUT} Sense = $(0.9) V_{REG}$, $I_{OUT} = I_A$, $T_J = 25^\circ\text{C}$		40		$\text{m}\Omega$

Note 2: This voltage has a positive temperature coefficient of approximately $3500\text{ppm}/^\circ\text{C}$.

Note 3: This resistance has a positive temperature coefficient of approximately $3500\text{ppm}/^\circ\text{C}$.

The total resistance from Pin 1 to Pin 8 will include an additional 60 to $100\text{m}\Omega$ of package resistance.

APPLICATION AND OPERATION INFORMATION

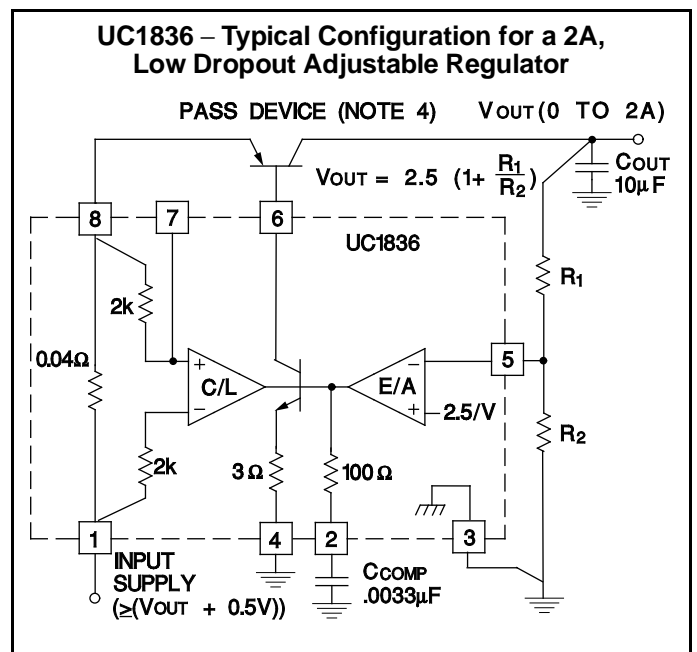
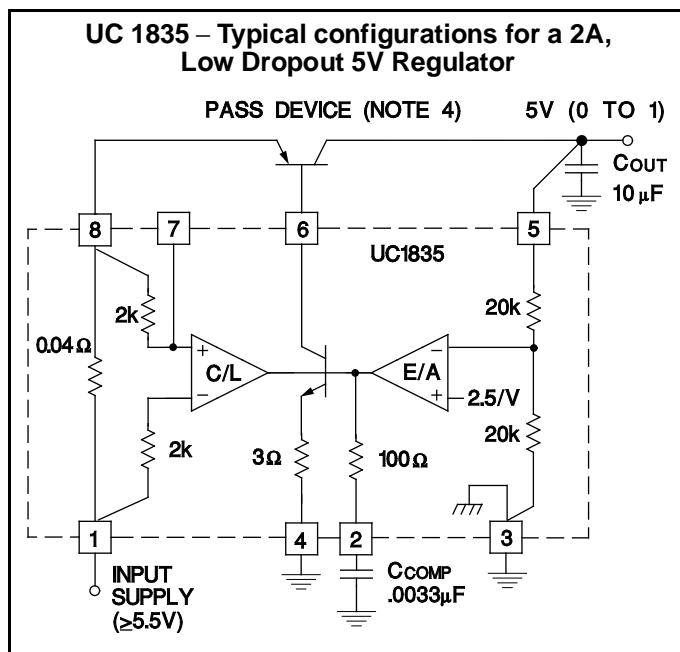

Note 4: Suggested Pass devices are TIP 32B. (Dropout Voltage $\leq 0.75\text{V}$) or, D45H, (Dropout Voltage $\leq 0.5\text{V}$), or equivalents.

APPLICATION AND OPERATION INFORMATION (cont.)

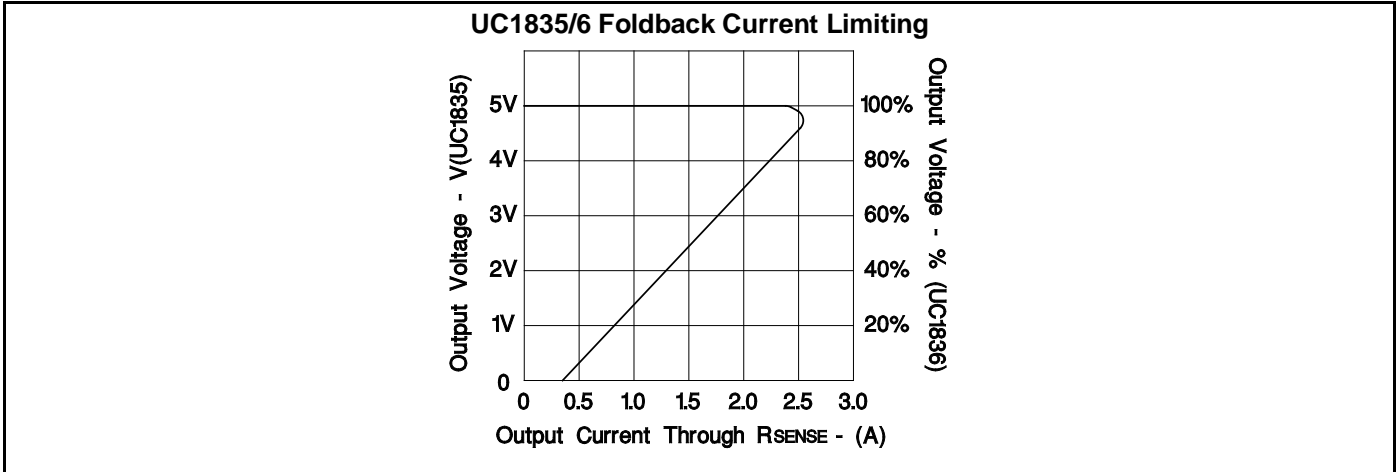

UC3835/36 TYPICAL APPLICATIONS

Low Current Application
using the UC3836 internal drive transistor

Typical Output Current vs VIN and VOUT
of the UC3836 internal drive transistor
for PDISS = 0.5W (approx.)

		VIN					
		Volts	5	9	12	15	18
VOUT	2	150	60	40	30	20	12
	5		105	55	35	25	15
	9			130	60	35	20
	12				120	55	25
	15					110	30
		Current in mA					

High Current Application
using drive transistor Q2 to increase Q1 base drive
and reduce UC3836 power dissipation

Parallel Pass Transistors
can be added for high current or
high power dissipation applications

EQUATIONS:

$R1 = 0.100 V/I_{OUT} (MAX)$

$R2 = (V_{OUT} - 2.5V/1mA)$

$R3 = ((V_{IN} - V_{BE} - V_{SAT}) * BETA(min)) / I_{OUT} (max)$

PACKAGING INFORMATION

Orderable Device	Status (1)	Package Type	Package Drawing	Pins	Package Qty	Eco Plan (2)	Lead/Ball Finish (6)	MSL Peak Temp (3)	Op Temp (°C)	Device Marking (4/5)	Samples
5962-9065002PA	ACTIVE	CDIP	JG	8	1	TBD	A42	N / A for Pkg Type	-55 to 125	9065002PA UC1836	Samples
UC1836J	ACTIVE	CDIP	JG	8	1	TBD	A42	N / A for Pkg Type	-55 to 125	UC1836J	Samples
UC1836J883B	ACTIVE	CDIP	JG	8	1	TBD	A42	N / A for Pkg Type	-55 to 125	9065002PA UC1836	Samples
UC2835D	ACTIVE	SOIC	D	8	75	Green (RoHS & no Sb/Br)	CU NIPDAU	Level-2-260C-1 YEAR	-25 to 85	UC2835D	Samples
UC2836D	ACTIVE	SOIC	D	8	75	Green (RoHS & no Sb/Br)	CU NIPDAU	Level-2-260C-1 YEAR	-25 to 85	UC2836D	Samples
UC2836DG4	ACTIVE	SOIC	D	8	75	Green (RoHS & no Sb/Br)	CU NIPDAU	Level-2-260C-1 YEAR	-25 to 85	UC2836D	Samples
UC3836D	ACTIVE	SOIC	D	8	75	Green (RoHS & no Sb/Br)	CU NIPDAU	Level-2-260C-1 YEAR	0 to 70	UC3836D	Samples
UC3836DG4	ACTIVE	SOIC	D	8	75	Green (RoHS & no Sb/Br)	CU NIPDAU	Level-2-260C-1 YEAR	0 to 70	UC3836D	Samples

(1) The marketing status values are defined as follows:

ACTIVE: Product device recommended for new designs.

LIFEBUY: TI has announced that the device will be discontinued, and a lifetime-buy period is in effect.

NRND: Not recommended for new designs. Device is in production to support existing customers, but TI does not recommend using this part in a new design.

PREVIEW: Device has been announced but is not in production. Samples may or may not be available.

OBSELETE: TI has discontinued the production of the device.

(2) **RoHS:** TI defines "RoHS" to mean semiconductor products that are compliant with the current EU RoHS requirements for all 10 RoHS substances, including the requirement that RoHS substance do not exceed 0.1% by weight in homogeneous materials. Where designed to be soldered at high temperatures, "RoHS" products are suitable for use in specified lead-free processes. TI may reference these types of products as "Pb-Free".

RoHS Exempt: TI defines "RoHS Exempt" to mean products that contain lead but are compliant with EU RoHS pursuant to a specific EU RoHS exemption.

Green: TI defines "Green" to mean the content of Chlorine (Cl) and Bromine (Br) based flame retardants meet JS709B low halogen requirements of <=1000ppm threshold. Antimony trioxide based flame retardants must also meet the <=1000ppm threshold requirement.

(3) MSL, Peak Temp. - The Moisture Sensitivity Level rating according to the JEDEC industry standard classifications, and peak solder temperature.

(4) There may be additional marking, which relates to the logo, the lot trace code information, or the environmental category on the device.

(5) Multiple Device Markings will be inside parentheses. Only one Device Marking contained in parentheses and separated by a "-" will appear on a device. If a line is indented then it is a continuation of the previous line and the two combined represent the entire Device Marking for that device.

(6) Lead/Ball Finish - Orderable Devices may have multiple material finish options. Finish options are separated by a vertical ruled line. Lead/Ball Finish values may wrap to two lines if the finish value exceeds the maximum column width.

Important Information and Disclaimer:The information provided on this page represents TI's knowledge and belief as of the date that it is provided. TI bases its knowledge and belief on information provided by third parties, and makes no representation or warranty as to the accuracy of such information. Efforts are underway to better integrate information from third parties. TI has taken and continues to take reasonable steps to provide representative and accurate information but may not have conducted destructive testing or chemical analysis on incoming materials and chemicals. TI and TI suppliers consider certain information to be proprietary, and thus CAS numbers and other limited information may not be available for release.

In no event shall TI's liability arising out of such information exceed the total purchase price of the TI part(s) at issue in this document sold by TI to Customer on an annual basis.

OTHER QUALIFIED VERSIONS OF UC1836, UC3836 :

- Catalog: [UC3836](#)

- Military: [UC1836](#)

NOTE: Qualified Version Definitions:

- Catalog - TI's standard catalog product

- Military - QML certified for Military and Defense Applications

IMPORTANT NOTICE

Texas Instruments Incorporated (TI) reserves the right to make corrections, enhancements, improvements and other changes to its semiconductor products and services per JESD46, latest issue, and to discontinue any product or service per JESD48, latest issue. Buyers should obtain the latest relevant information before placing orders and should verify that such information is current and complete.

TI's published terms of sale for semiconductor products (<http://www.ti.com/sc/docs/stdterms.htm>) apply to the sale of packaged integrated circuit products that TI has qualified and released to market. Additional terms may apply to the use or sale of other types of TI products and services.

Reproduction of significant portions of TI information in TI data sheets is permissible only if reproduction is without alteration and is accompanied by all associated warranties, conditions, limitations, and notices. TI is not responsible or liable for such reproduced documentation. Information of third parties may be subject to additional restrictions. Resale of TI products or services with statements different from or beyond the parameters stated by TI for that product or service voids all express and any implied warranties for the associated TI product or service and is an unfair and deceptive business practice. TI is not responsible or liable for any such statements.

Buyers and others who are developing systems that incorporate TI products (collectively, "Designers") understand and agree that Designers remain responsible for using their independent analysis, evaluation and judgment in designing their applications and that Designers have full and exclusive responsibility to assure the safety of Designers' applications and compliance of their applications (and of all TI products used in or for Designers' applications) with all applicable regulations, laws and other applicable requirements. Designer represents that, with respect to their applications, Designer has all the necessary expertise to create and implement safeguards that (1) anticipate dangerous consequences of failures, (2) monitor failures and their consequences, and (3) lessen the likelihood of failures that might cause harm and take appropriate actions. Designer agrees that prior to using or distributing any applications that include TI products, Designer will thoroughly test such applications and the functionality of such TI products as used in such applications.

TI's provision of technical, application or other design advice, quality characterization, reliability data or other services or information, including, but not limited to, reference designs and materials relating to evaluation modules, (collectively, "TI Resources") are intended to assist designers who are developing applications that incorporate TI products; by downloading, accessing or using TI Resources in any way, Designer (individually or, if Designer is acting on behalf of a company, Designer's company) agrees to use any particular TI Resource solely for this purpose and subject to the terms of this Notice.

TI's provision of TI Resources does not expand or otherwise alter TI's applicable published warranties or warranty disclaimers for TI products, and no additional obligations or liabilities arise from TI providing such TI Resources. TI reserves the right to make corrections, enhancements, improvements and other changes to its TI Resources. TI has not conducted any testing other than that specifically described in the published documentation for a particular TI Resource.

Designer is authorized to use, copy and modify any individual TI Resource only in connection with the development of applications that include the TI product(s) identified in such TI Resource. NO OTHER LICENSE, EXPRESS OR IMPLIED, BY ESTOPPEL OR OTHERWISE TO ANY OTHER TI INTELLECTUAL PROPERTY RIGHT, AND NO LICENSE TO ANY TECHNOLOGY OR INTELLECTUAL PROPERTY RIGHT OF TI OR ANY THIRD PARTY IS GRANTED HEREIN, including but not limited to any patent right, copyright, mask work right, or other intellectual property right relating to any combination, machine, or process in which TI products or services are used. Information regarding or referencing third-party products or services does not constitute a license to use such products or services, or a warranty or endorsement thereof. Use of TI Resources may require a license from a third party under the patents or other intellectual property of the third party, or a license from TI under the patents or other intellectual property of TI.

TI RESOURCES ARE PROVIDED "AS IS" AND WITH ALL FAULTS. TI DISCLAIMS ALL OTHER WARRANTIES OR REPRESENTATIONS, EXPRESS OR IMPLIED, REGARDING RESOURCES OR USE THEREOF, INCLUDING BUT NOT LIMITED TO ACCURACY OR COMPLETENESS, TITLE, ANY EPIDEMIC FAILURE WARRANTY AND ANY IMPLIED WARRANTIES OF MERCHANTABILITY, FITNESS FOR A PARTICULAR PURPOSE, AND NON-INFRINGEMENT OF ANY THIRD PARTY INTELLECTUAL PROPERTY RIGHTS. TI SHALL NOT BE LIABLE FOR AND SHALL NOT DEFEND OR INDEMNIFY DESIGNER AGAINST ANY CLAIM, INCLUDING BUT NOT LIMITED TO ANY INFRINGEMENT CLAIM THAT RELATES TO OR IS BASED ON ANY COMBINATION OF PRODUCTS EVEN IF DESCRIBED IN TI RESOURCES OR OTHERWISE. IN NO EVENT SHALL TI BE LIABLE FOR ANY ACTUAL, DIRECT, SPECIAL, COLLATERAL, INDIRECT, PUNITIVE, INCIDENTAL, CONSEQUENTIAL OR EXEMPLARY DAMAGES IN CONNECTION WITH OR ARISING OUT OF TI RESOURCES OR USE THEREOF, AND REGARDLESS OF WHETHER TI HAS BEEN ADVISED OF THE POSSIBILITY OF SUCH DAMAGES.

Unless TI has explicitly designated an individual product as meeting the requirements of a particular industry standard (e.g., ISO/TS 16949 and ISO 26262), TI is not responsible for any failure to meet such industry standard requirements.



Where TI specifically promotes products as facilitating functional safety or as compliant with industry functional safety standards, such products are intended to help enable customers to design and create their own applications that meet applicable functional safety standards and requirements. Using products in an application does not by itself establish any safety features in the application. Designers must ensure compliance with safety-related requirements and standards applicable to their applications. Designer may not use any TI products in life-critical medical equipment unless authorized officers of the parties have executed a special contract specifically governing such use. Life-critical medical equipment is medical equipment where failure of such equipment would cause serious bodily injury or death (e.g., life support, pacemakers, defibrillators, heart pumps, neurostimulators, and implantables). Such equipment includes, without limitation, all medical devices identified by the U.S. Food and Drug Administration as Class III devices and equivalent classifications outside the U.S.

TI may expressly designate certain products as completing a particular qualification (e.g., Q100, Military Grade, or Enhanced Product). Designers agree that it has the necessary expertise to select the product with the appropriate qualification designation for their applications and that proper product selection is at Designers' own risk. Designers are solely responsible for compliance with all legal and regulatory requirements in connection with such selection.

Designer will fully indemnify TI and its representatives against any damages, costs, losses, and/or liabilities arising out of Designer's non-compliance with the terms and provisions of this Notice.

Looking for pricing, stock, or lifecycle information?

Click below to explore more details on WIN SOURCE:

-  [View UC2836D on WIN SOURCE](#)
-  [Texas Instruments](#) Information

Optimize Your Supply Chain with WIN SOURCE Solutions

-  Global Sourcing Solution
-  Obsolete Management
-  Cost Control Management
-  Shortage Management
-  Alternative Solution
-  Excess Inventory Management