



**THE DATASHEET OF  
DVIULC6-4SC6Y**



## Automotive ultralow capacitance ESD protection

Datasheet – production data

### Features

- 4-line ESD protection (IEC 61000-4-2)
- Protects  $V_{BUS}$  when applicable
- Ultralow capacitance: 0.6 pF at  $F = 825$  MHz
- Fast response time compared with varistors
- RoHS compliant
- AEC-Q101 qualified

### Benefits

- ESD protection of  $V_{BUS}$
- Optimized rise and fall times for maximum data integrity
- Consistent D+ / D- signal balance:
  - Optimum capacitance matching tolerance for ultralow intra pair skew:  
I/O to ground = 0.015 pF,  
I/O to I/O = 0.007 pF
  - Matching high bit rate DVI, HDMI, and IDB 1394 bus requirements
- Low PCB space occupation: 9 mm<sup>2</sup>
- Higher reliability offered by monolithic integration

### Complies with these standards

- ISO 10605 (C = 330 pF, R = 330  $\Omega$ )
  - 18 kV (air discharge)
  - 18 kV (contact discharge)
- ISO 10605 (C = 150 pF, R = 330  $\Omega$ )
  - 18 kV (air discharge)
  - 18 kV (contact discharge)
- MIL STD883G-Method 3015-7
- ISO 7637-2
  - Pulse 3a:  $V_S = -150$  V
  - Pulse 3b:  $V_S = 100$  V

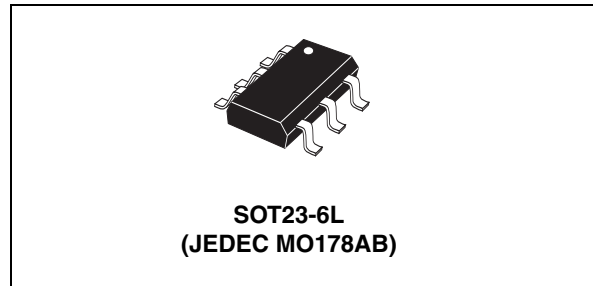

### Applications

- DVI ports up to 1.65 Gb/s
- HDMI ports up to 1.65 Gb/s
- IDB 1394
- USB 2.0 ports up to 480 Mb/s (high speed), backwards compatible with USB1.1 low and full speed
- Ethernet port: 10/100/1000 Mb/s
- SIM card protection
- Video line protection

### Description

The DVIULC6-4SC6Y is a monolithic, application specific discrete device dedicated to ESD protection of high speed interfaces, such as DVI, HDMI, IDB 1394 bus, USB2.0, Ethernet links and video lines.

Its ultralow line capacitance secures a high level of signal integrity without compromise in protecting sensitive chips against the most stringently characterized ESD strikes.

# 1 Characteristics

Figure 1. Functional diagram

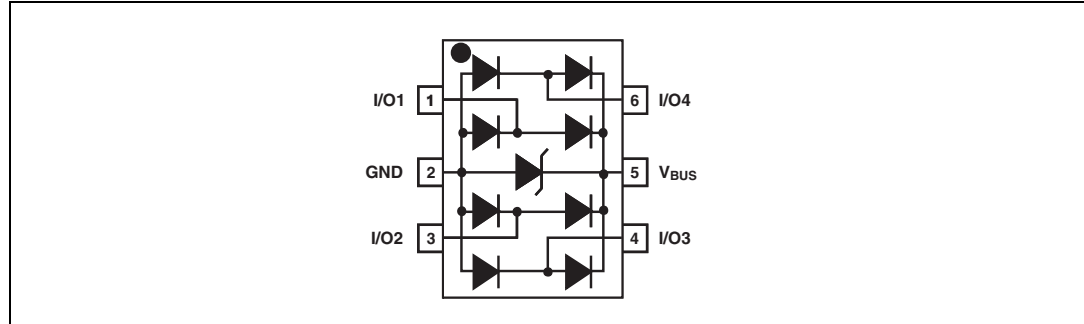

Table 1. Absolute ratings

Symbol	Parameter		Value	Unit
V <sub>PP</sub>	Peak pulse voltage	ISO 10605 (C = 330 pF, R = 330 Ω)	±18	kV
		air discharge	±18	
		contact discharge	±18	
		ISO 10605 (C = 150 pF, R = 330 Ω)	±18	
		air discharge	±18	
		contact discharge	±18	
		MIL STD883G-Method 3015-7	±25	
T <sub>stg</sub>	Storage temperature range		-65 to +150	°C
T <sub>j</sub>	Operating junction temperature range		-40 to +150	°C
T <sub>L</sub>	Lead solder temperature (10 seconds duration)		260	°C

Table 2. Electrical characteristics (T<sub>amb</sub> = 25 °C)

Symbol	Parameter	Test conditions	Value			Unit
			Min.	Typ.	Max.	
I <sub>RM</sub>	Leakage current	V <sub>RM</sub> = 5 V			0.5	µA
V <sub>BR</sub>	Breakdown voltage between V <sub>BUS</sub> and GND	I <sub>R</sub> = 1 mA	6			V
V <sub>CL</sub>	Clamping voltage	I <sub>PP</sub> = 1 A, t <sub>p</sub> = 8/20 µs Any I/O pin to GND			12	V
		I <sub>PP</sub> = 5 A, t <sub>p</sub> = 8/20 µs Any I/O pin to GND			17	V
C <sub>i/o-GND</sub>	Capacitance between I/O and GND	V <sub>R</sub> = 0 V, F = 1 MHz		0.85	1	pF
		V <sub>R</sub> = 0 V, F = 825 MHz		0.6		
ΔC <sub>i/o-GND</sub>	Capacitance variation between I/O and GND			0.015		
C <sub>i/o-i/o</sub>	Capacitance between I/O	V <sub>R</sub> = 0 V, F = 1 MHz		0.42	0.5	pF
		V <sub>R</sub> = 0 V, F = 825 MHz		0.3		
ΔC <sub>i/o-i/o</sub>	Capacitance variation between I/O			0.007		

Figure 2. Line capacitance versus line voltage (typical values)

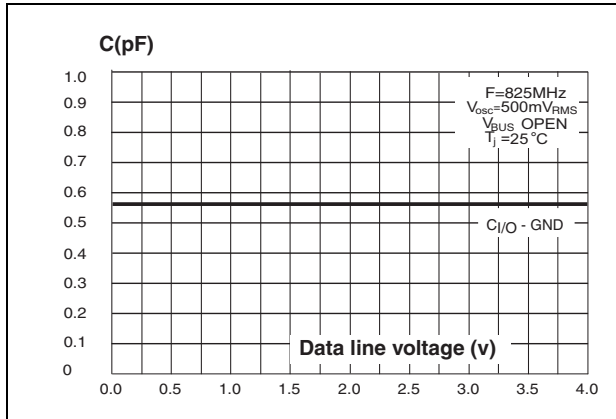

Figure 3. Line capacitance versus frequency (typical values)

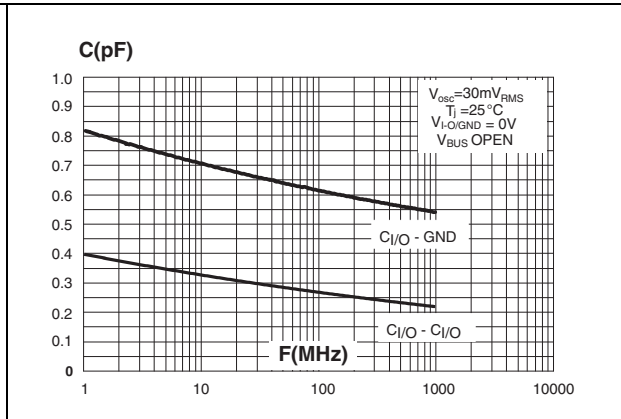

Figure 4. Relative variation of leakage current versus junction temperature (typical values)

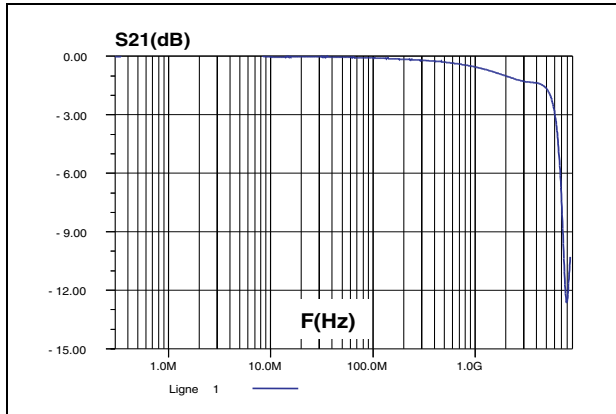

Figure 5. Frequency response

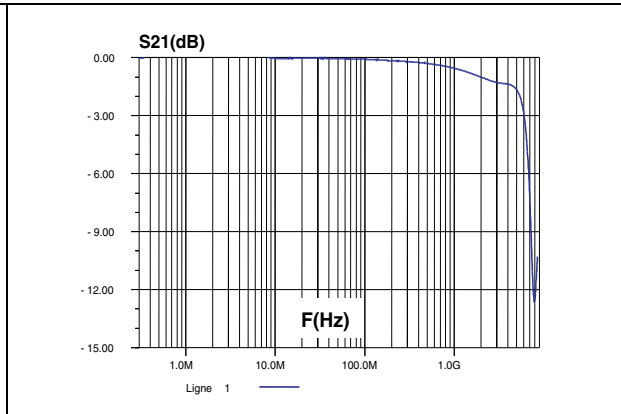

Figure 6. Remaining voltage after the DVIULC6-4SC6Y during positive ESD surge<sup>(1)</sup>

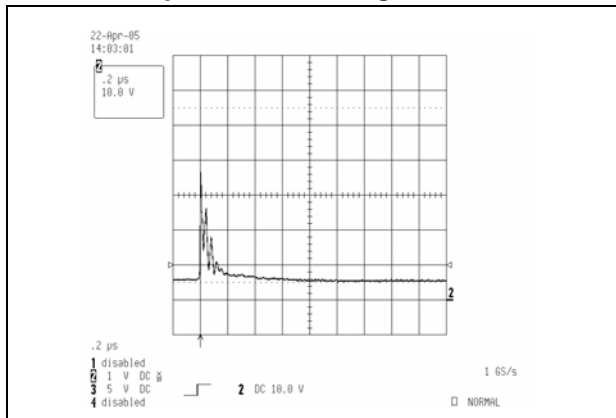
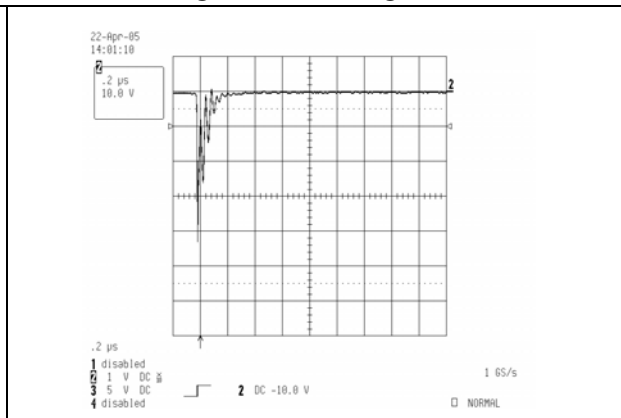

Figure 7. Remaining voltage after the DVIULC6-4SC6Y during negative ESD surge<sup>(1)</sup>



1. measurements were done with DVIULC-4SC6 in open circuit

Figure 8. Analog crosstalk results

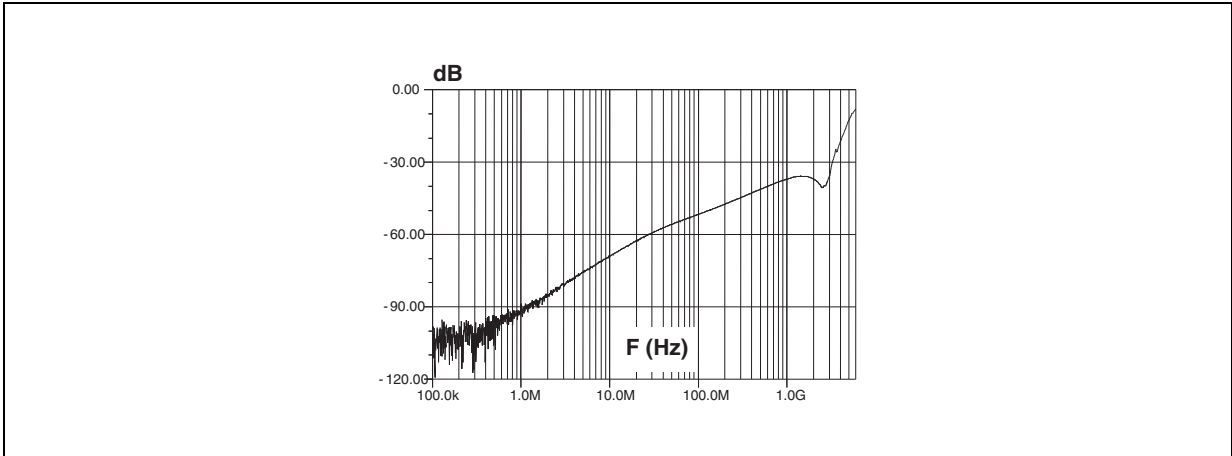

Figure 9. ISO 7637-2 pulse 3a response ( $V_S = -150\text{ V}$ )

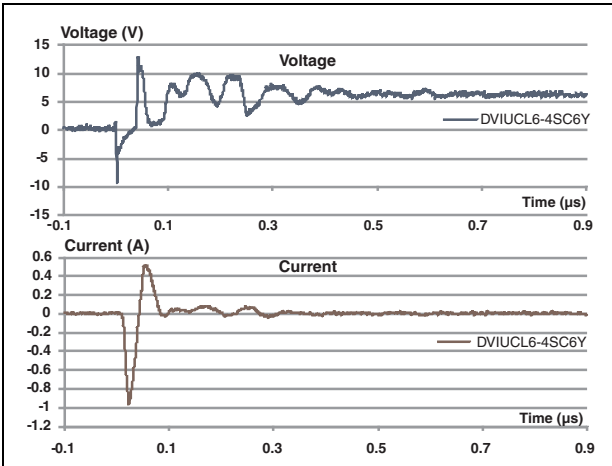
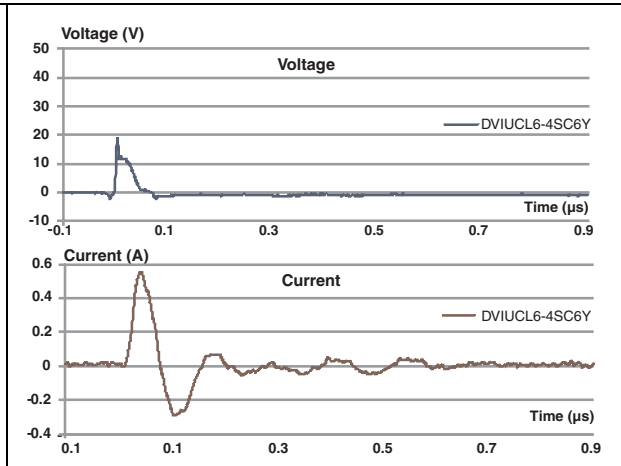

Figure 10. ISO 7637-2 pulse 3b response ( $V_S = 100\text{ V}$ )



## 2 Application examples

More information is available in the STMicroelectronics Application note AN2689 “Protection of automotive electronics from electrical hazards, guidelines for design and component selection”.

**Figure 11. DVI/HDMI digital single link application**

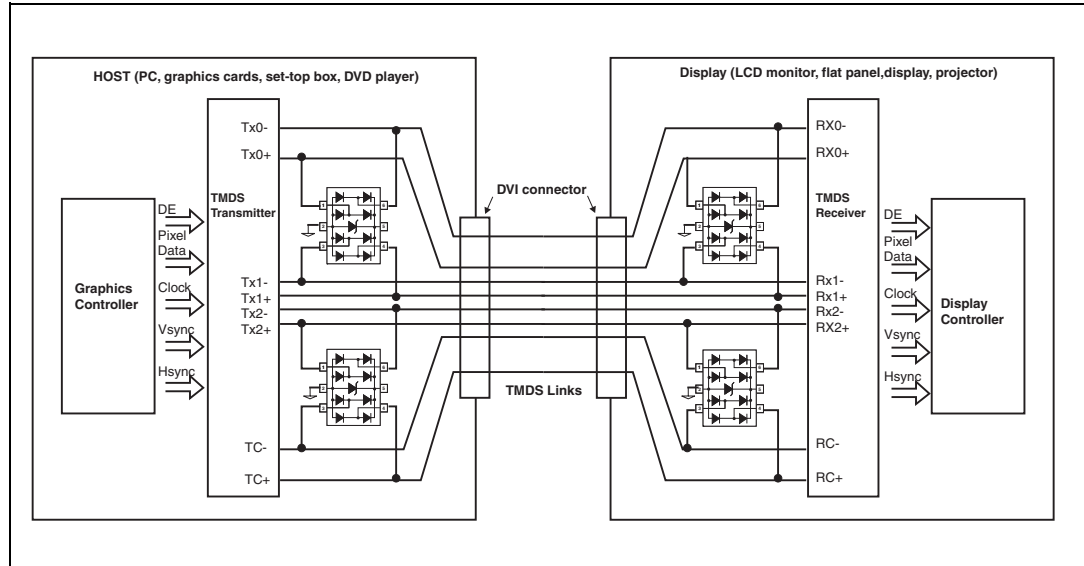

**Figure 12. T1/E1/Ethernet protection**

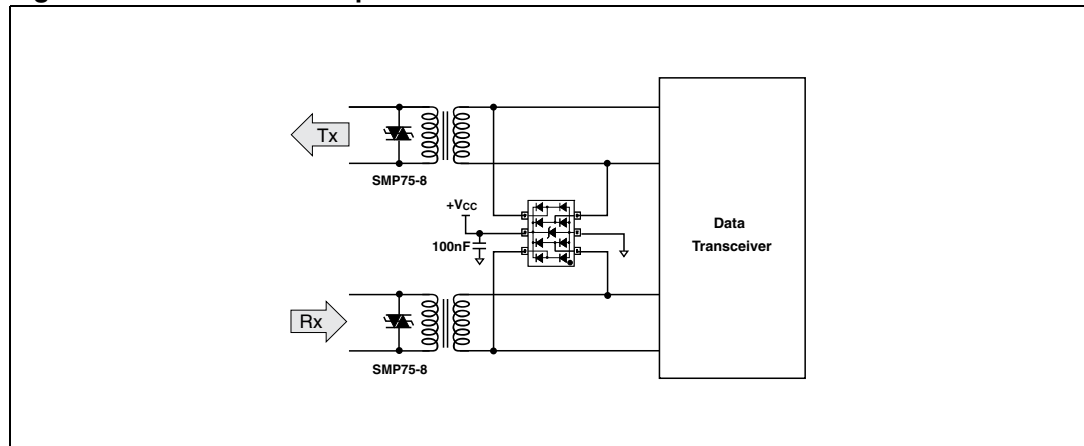

## 3 Technical information

### 3.1 Surge protection

The DVIULC6-4SC6Y is particularly optimized to perform ESD surge protection based on the rail to rail topology.

The clamping voltage  $V_{CL}$  can be calculated as follows:

$$V_{CL+} = V_{BUS} + V_F \text{ for positive surges}$$

$$V_{CL-} = -V_F \text{ for negative surges}$$

with:  $V_F = V_T + R_d \cdot I_p$

( $V_F$  = forward drop voltage) / ( $V_T$  = forward drop threshold voltage)

#### Calculation example

We can assume that the value of the dynamic resistance of the clamping diode is typically:  $R_d = 1.4 \Omega$  and  $V_T = 1.2 \text{ V}$ .

For an IEC 61000-4-2 surge Level 4 (Contact Discharge:  $V_g = 8 \text{ kV}$ ,  $R_g = 330 \Omega$ ),  $V_{BUS} = +5 \text{ V}$ , and, in a first approximation, we assume that:  $I_p = V_g / R_g = 24 \text{ A}$ .

We find:

$$V_{CL+} = +39 \text{ V}$$

$$V_{CL-} = -34 \text{ V}$$

*Note:* The calculations do not take into account phenomena due to parasitic inductances.

### 3.2 Surge protection application example

If we consider that the connections from the pin  $V_{BUS}$  to  $V_{CC}$  and from GND to PCB GND plane are two tracks 10 mm long and 0.5 mm wide, we can assume that the parasitic inductances,  $L_W$  of these tracks are about 6 nH. So when an IEC 61000-4-2 surge occurs, due to the rise time of this spike ( $t_r = 1 \text{ ns}$ ), the voltage  $V_{CL}$  has an extra value equal to  $L_W \cdot di/dt$ .

The  $di/dt$  is calculated as:  $di/dt = I_p/t_r = 24 \text{ A/ns}$  for an IEC 61000-4-2 surge level 4 (contact discharge  $V_g = 8 \text{ kV}$ ,  $R_g = 330 \Omega$ )

The over voltage due to the parasitic inductances is:  $L_W \cdot di/dt = 6 \times 24 = 144 \text{ V}$

By taking into account the effect of these parasitic inductances due to unsuitable layout, the clamping voltage will be:

$$V_{CL+} = +39 + 144 = 183 \text{ V}$$

$$V_{CL-} = -34 - 144 = -178 \text{ V}$$

We can reduce as much as possible these phenomena with simple layout optimization.

This is the reason why some recommendations have to be followed (see [Section 3.3: How to ensure good ESD protection](#)).

### 3.3 How to ensure good ESD protection

While the DVIULC6-4SC6Y provides a high immunity to ESD surge, an efficient protection depends on the layout of the board. In the same way, with the rail to rail topology, the track from V<sub>BUS</sub> pin to the power supply +V<sub>CC</sub>, and from V<sub>BUS</sub> pin to GND pin must be as short as possible to avoid over voltages due to parasitic phenomena (see [Figure 13](#) and [Figure 14](#) for layout considerations).

**Figure 13. IESD behavior: parasitic phenomena due to unsuitable layout**

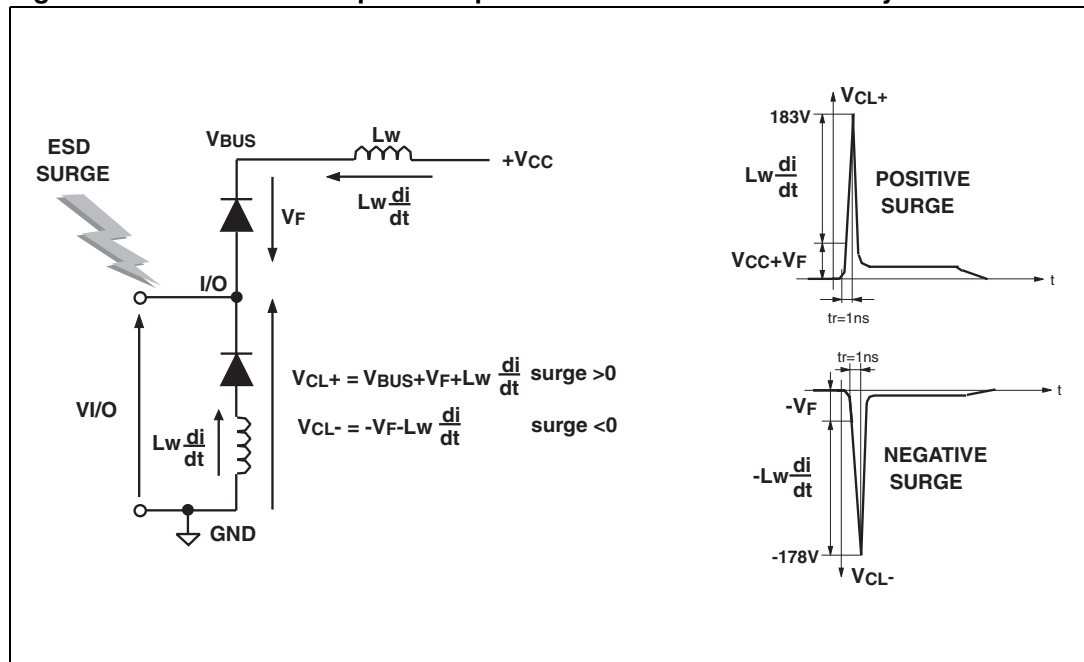

**Figure 14. ESD behavior: layout optimization and addition of a 100 nF capacitor**

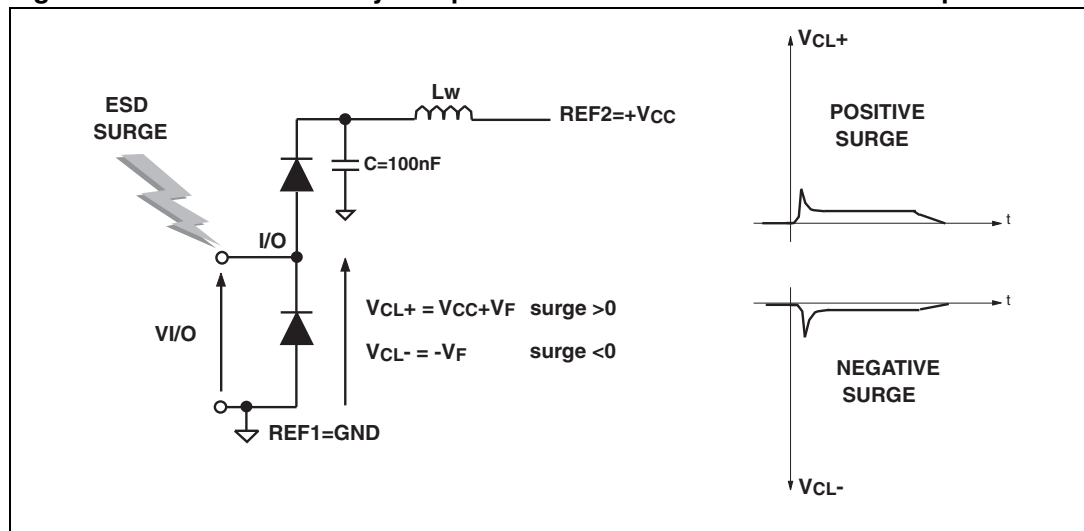

**Figure 15. PCB layout considerations ( $V_{CC}$  connection is application dependent)**

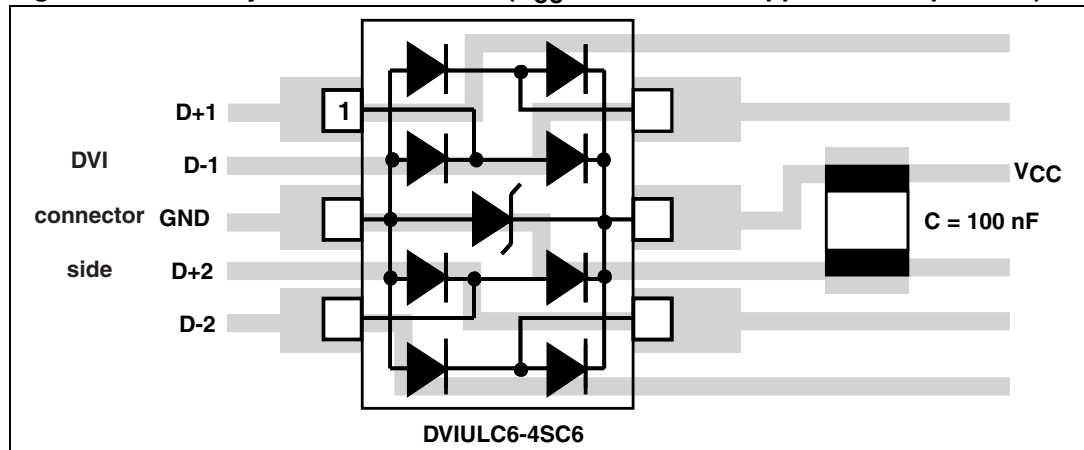

It's often harder to connect the power supply near to the DVIULC6-4SC6Y unlike the ground thanks to the ground plane that allows a short connection.

To ensure the same efficiency for positive surges when the connections can't be short enough, we recommend to put close to the DVIULC6-4SC6Y, between  $V_{BUS}$  and ground, a capacitance of 100 nF to prevent from these kinds of overfatigue disturbances (see [Figure 14](#) and [Figure 15](#)).

The addition of this capacitance will allow a better protection by providing a constant voltage during a surge.

[Figure 16](#), [Figure 6](#), and [Figure 7](#) show the improvement of the ESD protection according to the recommendations described in [Section 3.3](#).

**Figure 16. ESD behavior: measurement conditions (with coupling capacitor)**

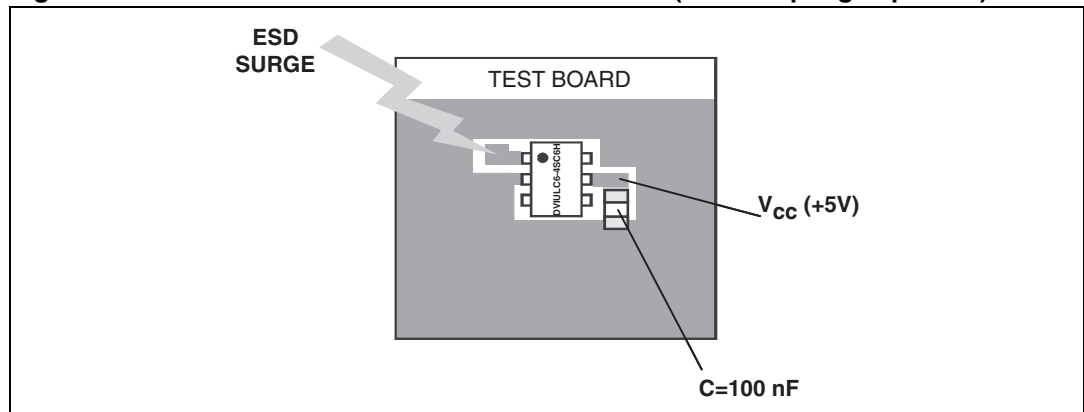

### Important

An important precaution to take is to put the protection device as close as possible to the disturbance source (generally the connector).

### 3.4 Crosstalk behavior

Figure 17. Crosstalk phenomena

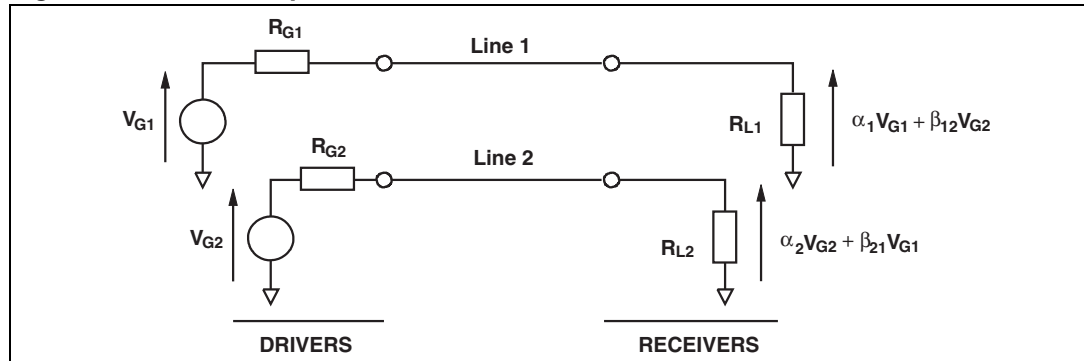

The crosstalk phenomena is due to the coupling between 2 lines. The coupling factor ( $\beta_{12}$  or  $\beta_{21}$ ) increases when the gap across lines decreases, particularly in silicon dice. In the example above the expected signal on load  $R_{L2}$  is  $\alpha_2 V_{G2}$ , in fact the real voltage at this point has got an extra value  $\beta_{21} V_{G1}$ . This part of the  $V_{G1}$  signal represents the effect of the crosstalk phenomenon of line 1 on line 2. This phenomenon has to be taken into account when the drivers impose fast digital data or high frequency analog signals in the disturbing line. The perturbed line will be more affected if it works with low voltage signal or high load impedance (few  $k\Omega$ ).

Figure 18. Analog crosstalk measurements

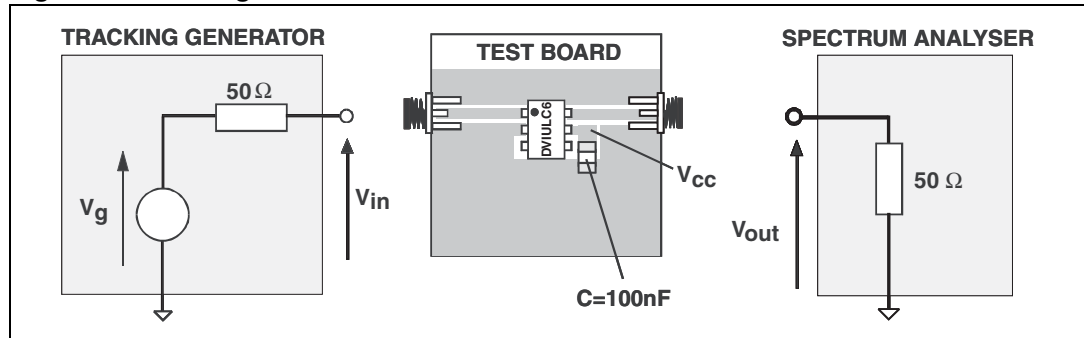

Figure 18 gives the measurement circuit for the analog application. In usual frequency range of analog signals (up to 240 MHz) the effect on disturbed line is less than -45 dB (see Figure 8).

As the DVIULC6-4SC6Y is designed to protect high speed data lines, it must ensure a good transmission of operating signals. The frequency response (Figure 5) gives attenuation information and shows that the DVIULC6-4SC6Y is well suitable for data line transmission up to 1.65 Gb/s.

# 4 Package information

- Epoxy meets UL94, V0
- Lead-free package

In order to meet environmental requirements, ST offers these devices in different grades of ECOPACK® packages, depending on their level of environmental compliance. ECOPACK® specifications, grade definitions and product status are available at: [www.st.com](http://www.st.com). ECOPACK® is an ST trademark.

**Table 3. SOT23-6L dimensions**

Ref.	Dimensions					
	Millimeters			Inches		
	Min.	Typ.	Max.	Min.	Typ.	Max.
A	0.90		1.45	0.035		0.057
A1	0		0.15	0		0.006
A2	0.90		1.30	0.035		0.051
b	0.30		0.50	0.012		0.020
c	0.09		0.20	0.004		0.008
D	2.80		3.05	0.11		0.118
E	1.50		1.75	0.059		0.069
e		0.95			0.037	
H	2.60		3.00	0.102		0.118
L	0.30		0.60	0.012		0.024
θ	0°		10°	0°		10°

**Figure 19. Footprint - dimensions in mm (inches)**

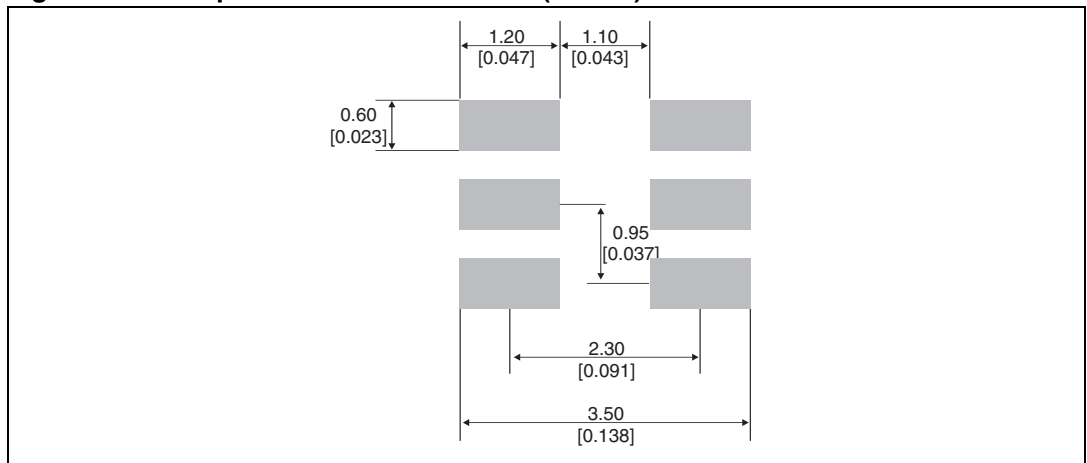

## 5 Ordering information

Table 4. Ordering information

Order code	Marking	Package	Weight	Base qty	Delivery mode
DVIULC6-4SC6Y	DL4Y	SOT23-6L	16.7 mg	3000	Tape and reel

## 6 Revision history

Table 5. Document revision history

Date	Revision	Changes
24-May-2011	1	First issue.
06-Sep-2012	2	Updated dimension A1 max., b min., and L min. in <a href="#">Table 3</a> .

**Please Read Carefully:**

Information in this document is provided solely in connection with ST products. STMicroelectronics NV and its subsidiaries ("ST") reserve the right to make changes, corrections, modifications or improvements, to this document, and the products and services described herein at any time, without notice.

All ST products are sold pursuant to ST's terms and conditions of sale.

Purchasers are solely responsible for the choice, selection and use of the ST products and services described herein, and ST assumes no liability whatsoever relating to the choice, selection or use of the ST products and services described herein.

No license, express or implied, by estoppel or otherwise, to any intellectual property rights is granted under this document. If any part of this document refers to any third party products or services it shall not be deemed a license grant by ST for the use of such third party products or services, or any intellectual property contained therein or considered as a warranty covering the use in any manner whatsoever of such third party products or services or any intellectual property contained therein.

**UNLESS OTHERWISE SET FORTH IN ST'S TERMS AND CONDITIONS OF SALE ST DISCLAIMS ANY EXPRESS OR IMPLIED WARRANTY WITH RESPECT TO THE USE AND/OR SALE OF ST PRODUCTS INCLUDING WITHOUT LIMITATION IMPLIED WARRANTIES OF MERCHANTABILITY, FITNESS FOR A PARTICULAR PURPOSE (AND THEIR EQUIVALENTS UNDER THE LAWS OF ANY JURISDICTION), OR INFRINGEMENT OF ANY PATENT, COPYRIGHT OR OTHER INTELLECTUAL PROPERTY RIGHT.**

**UNLESS EXPRESSLY APPROVED IN WRITING BY TWO AUTHORIZED ST REPRESENTATIVES, ST PRODUCTS ARE NOT RECOMMENDED, AUTHORIZED OR WARRANTED FOR USE IN MILITARY, AIR CRAFT, SPACE, LIFE SAVING, OR LIFE SUSTAINING APPLICATIONS, NOR IN PRODUCTS OR SYSTEMS WHERE FAILURE OR MALFUNCTION MAY RESULT IN PERSONAL INJURY, DEATH, OR SEVERE PROPERTY OR ENVIRONMENTAL DAMAGE. ST PRODUCTS WHICH ARE NOT SPECIFIED AS "AUTOMOTIVE GRADE" MAY ONLY BE USED IN AUTOMOTIVE APPLICATIONS AT USER'S OWN RISK.**

Resale of ST products with provisions different from the statements and/or technical features set forth in this document shall immediately void any warranty granted by ST for the ST product or service described herein and shall not create or extend in any manner whatsoever, any liability of ST.

ST and the ST logo are trademarks or registered trademarks of ST in various countries.

Information in this document supersedes and replaces all information previously supplied.

The ST logo is a registered trademark of STMicroelectronics. All other names are the property of their respective owners.

© 2012 STMicroelectronics - All rights reserved

STMicroelectronics group of companies

Australia - Belgium - Brazil - Canada - China - Czech Republic - Finland - France - Germany - Hong Kong - India - Israel - Italy - Japan - Malaysia - Malta - Morocco - Philippines - Singapore - Spain - Sweden - Switzerland - United Kingdom - United States of America

[www.st.com](http://www.st.com)

## Looking for pricing, stock, or lifecycle information?

Click below to explore more details on WIN SOURCE:

- ⊖ [View DVIULC6-4SC6Y on WIN SOURCE](#)
- ⊖ [STMicroelectronics](#) Information

## Optimize Your Supply Chain with WIN SOURCE Solutions

- ✓ Global Sourcing Solution
- ✓ Obsolete Management
- ✓ Cost Control Management
- ✓ Shortage Management
- ✓ Alternative Solution
- ✓ Excess Inventory Management