



THE DATASHEET OF 74LX1G04STR





74LX1G04

LOW VOLTAGE CMOS SINGLE INVERTER WITH 5V TOLERANT INPUT

- 5V TOLERANT INPUTS
- HIGH SPEED: $t_{PD} = 4.2\text{ns}$ (MAX.) at $V_{CC} = 3\text{V}$
- LOW POWER DISSIPATION:
 $I_{CC} = 1\mu\text{A}$ (MAX.) at $T_A = 25^\circ\text{C}$
- POWER DOWN PROTECTION ON INPUTS AND OUTPUTS
- SYMMETRICAL OUTPUT IMPEDANCE:
 $|I_{OH}| = I_{OL} = 24\text{mA}$ (MIN) at $V_{CC} = 3\text{V}$
- BALANCED PROPAGATION DELAYS:
 $t_{PLH} \approx t_{PHL}$
- OPERATING VOLTAGE RANGE:
 $V_{CC}(\text{OPR}) = 1.65\text{V}$ to 5.5V
(1.2V Data Retention)
- IMPROVED LATCH-UP IMMUNITY

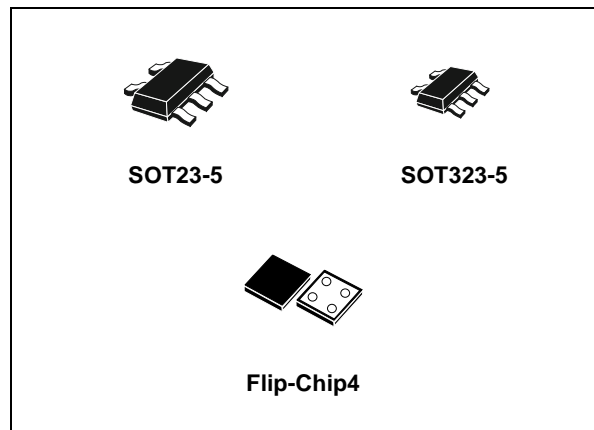

DESCRIPTION

The 74LX1G04 is a low voltage CMOS SINGLE INVERTER fabricated with sub-micron silicon gate and double-layer metal wiring C²MOS technology.

It is ideal for 1.65 to 5.5 V_{CC} operations and low power and low noise applications. The internal circuit is composed of 3 stages including buffer output, which provide high noise immunity and stable output.

Power down protection is provided on input and output and 0 to 7V can be accepted on inputs with

ORDER CODES

PACKAGE	T & R
SOT23-5L	74LX1G04STR
SOT323-5L	74LX1G04CTR
Flip-Chip	74LX1G04BJR

no regard to the supply voltage. It can be interfaced to 5V signal environment for inputs in mixed 3.3/5V system.

All inputs and outputs are equipped with protection circuits against static discharge.

PIN CONNECTION AND IEC LOGIC SYMBOLS (top view for SOT, top through view for Flip-Chip)

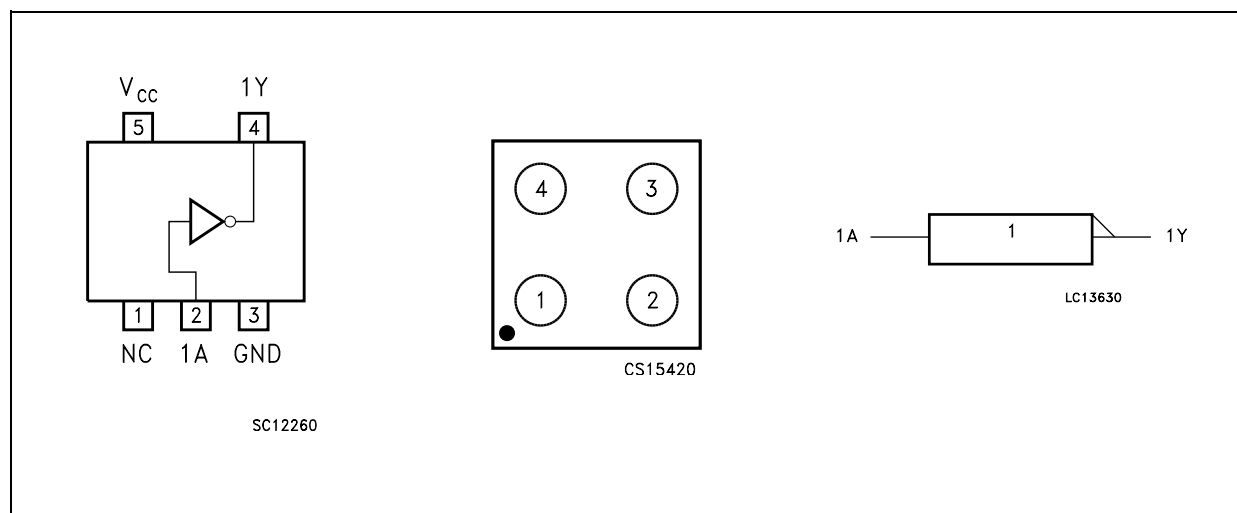

74LX1G04

INPUT AND OUTPUT EQUIVALENT CIRCUIT

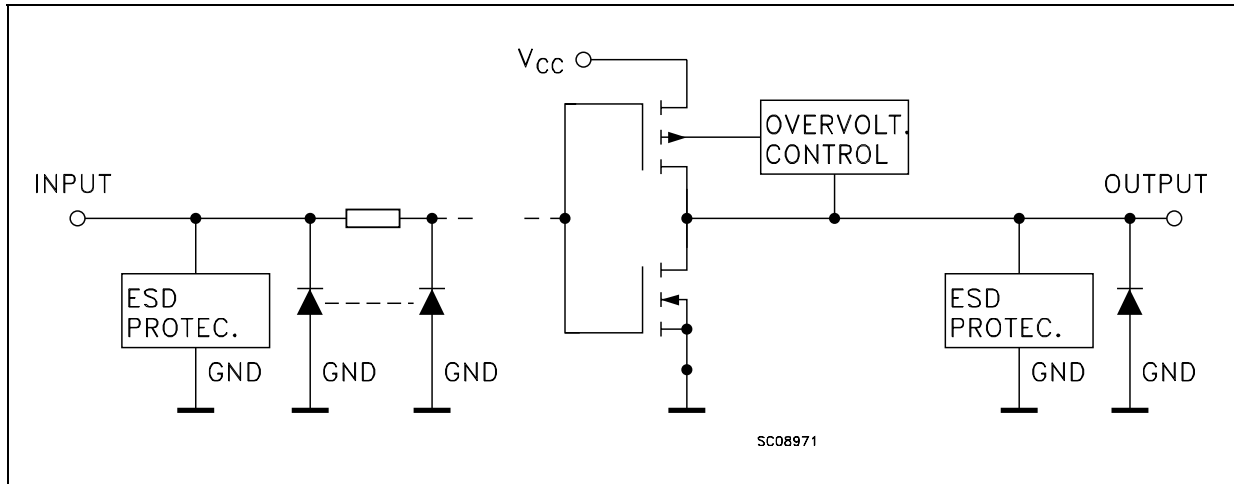

PIN DESCRIPTION

PIN for SOT	PIN for Flip-Chip	SYMBOL	NAME AND FUNCTION
1		N.C.	Not connected
2	1	1A	Data Input
4	3	1Y	Data Output
3	2	GND	Ground (0V)
5	4	V _{CC}	Positive Supply Voltage

TRUTH TABLE

A	Y
L	H
H	L

ABSOLUTE MAXIMUM RATINGS

Symbol	Parameter	Value	Unit
V _{CC}	Supply Voltage	-0.5 to +7.0	V
V _I	DC Input Voltage	-0.5 to +7.0	V
V _O	DC Output Voltage (V _{CC} = 0V)	-0.5 to +7.0	V
V _O	DC Output Voltage (High or Low State) (note 1)	-0.5 to V _{CC} + 0.5	V
I _{IK}	DC Input Diode Current	- 50	mA
I _{OK}	DC Output Diode Current (note 2)	- 50	mA
I _O	DC Output Current	± 50	mA
I _{CC} or I _{GND}	DC V _{CC} or Ground Current per Supply Pin	± 50	mA
T _{stg}	Storage Temperature	-65 to +150	°C
T _L	Lead Temperature (10 sec)	260	°C

Absolute Maximum Rating are those value beyond which damage to the device may occur. Functional operation under these condition is not implied

1) I_O absolute maximum rating must be observed

2) V_O < GND

RECOMMENDED OPERATING CONDITIONS

Symbol	Parameter	Value	Unit
V_{CC}	Supply Voltage (note 1)	1.65 to 5.5	V
V_I	Input Voltage	0 to 5.5	V
V_O	Output Voltage ($V_{CC} = 0V$)	0 to 5.5	V
V_O	Output Voltage (High or Low State)	0 to V_{CC}	V
I_{OH}, I_{OL}	High or Low Level Output Current ($V_{CC} = 4.5$ to $5.5V$)	± 32	mA
I_{OH}, I_{OL}	High or Low Level Output Current ($V_{CC} = 3.0$ to $3.6V$)	± 24	mA
I_{OH}, I_{OL}	High or Low Level Output Current ($V_{CC} = 2.7$ to $3.0V$)	± 16	mA
I_{OH}, I_{OL}	High or Low Level Output Current ($V_{CC} = 2.3$ to $2.7V$)	± 8	mA
I_{OH}, I_{OL}	High or Low Level Output Current ($V_{CC} = 1.65$ to $2.3V$)	± 4	mA
T_{op}	Operating Temperature	-55 to 125	$^{\circ}C$
dt/dv	Input Rise and Fall Time (note 2)	0 to 10	ns/V

1) Truth Table guaranteed: 1.2V to 3.6V

2) V_{IN} from 0.8V to 2V at $V_{CC} = 3.0V$

DC SPECIFICATION

Symbol	Parameter	Test Condition		Value				Unit
		V_{CC} (V)		-40 to 85 $^{\circ}C$		-55 to 125 $^{\circ}C$		
				Min.	Max.	Min.	Max.	
V_{IH}	High Level Input Voltage	1.65 to 1.95		$0.75V_{CC}$		$0.75V_{CC}$		V
		2.3 to 2.7		$0.7V_{CC}$		$0.7V_{CC}$		
		3.0 to 5.5		$0.7V_{CC}$		$0.7V_{CC}$		
V_{IL}	Low Level Input Voltage	1.65 to 1.95			$0.25V_{CC}$		$0.25V_{CC}$	V
		2.3 to 2.7			$0.3V_{CC}$		$0.3V_{CC}$	
		3.0 to 5.5			$0.3V_{CC}$		$0.3V_{CC}$	
V_{OH}	High Level Output Voltage	1.65 to 4.5	$I_O = -100 \mu A$	$V_{CC} - 0.1$		$V_{CC} - 0.1$		V
		1.65	$I_O = -4 \text{ mA}$	1.2		1.2		
		2.3	$I_O = -8 \text{ mA}$	1.9		1.9		
		3.0	$I_O = -16 \text{ mA}$	2.4		2.4		
			$I_O = -24 \text{ mA}$	2.2		2.2		
4.5	$I_O = -32 \text{ mA}$	3.8		3.8				
V_{OL}	Low Level Output Voltage	1.65 to 4.5	$I_O = 100 \mu A$		0.1		0.1	V
		1.65	$I_O = 4 \text{ mA}$		0.45		0.45	
		2.3	$I_O = 8 \text{ mA}$		0.3		0.3	
		3.0	$I_O = 16 \text{ mA}$		0.4		0.4	
			$I_O = 24 \text{ mA}$		0.55		0.55	
4.5	$I_O = 32 \text{ mA}$		0.55		0.55			
I_I	Input Leakage Current	1.65 to 5.5	$V_I = 0$ to $5.5V$		± 10		± 10	μA
I_{off}	Power Off Leakage Current	0	V_I or $V_O = 5.5V$		10		10	μA
I_{CC}	Quiescent Supply Current	1.65 to 5.5	$V_I = V_{CC}$ or GND		10		10	μA

AC ELECTRICAL CHARACTERISTICS

Symbol	Parameter	Test Condition				Value				Unit
		V _{CC} (V)	C _L (pF)	R _L (Ω)	t _s = t _r (ns)	-40 to 85 °C		-55 to 125 °C		
						Min.	Max.	Min.	Max.	
t _{PLH} t _{PHL}	Propagation Delay Time	1.65 to 1.95	15	1MΩ	2.0	2	9.5	2	10.5	ns
		2.3 to 2.7				2	6.5	2	7.6	
		3.0 to 3.6				1	5.5	1	6.5	
		4.5 to 5.5				1	4.1	1	5.5	
		1.65 to 1.95	30	1000	2.0	2	10.5	2	11.5	
		2.3 to 2.7	30	500	2.0	2	7.5	2	8.5	
		2.7	50	500	2.5	1	6.1	1	7.1	
		3.0 to 3.6	50	500	2.5	1	5.5	1	6.5	
		4.5 to 5.5	50	500	2.5	1	4.2	1	5.2	

CAPACITANCE CHARACTERISTICS

Symbol	Parameter	Test Condition		Value			Unit
		V _{CC} (V)		T _A = 25 °C			
				Min.	Typ.	Max.	
C _{IN}	Input Capacitance	0			4		pF
C _{PD}	Power Dissipation Capacitance (note 1)	1.8	f _{IN} = 10MHz		36.8		pF
		2.5			37		
		3.3			38		

1) C_{PD} is defined as the value of the IC's internal equivalent capacitance which is calculated from the operating current consumption without load. (Refer to Test Circuit). Average current can be obtained by the following equation. $I_{CC(opr)} = C_{PD} \times V_{CC} \times f_{IN} + I_{CC}$

TEST CIRCUIT

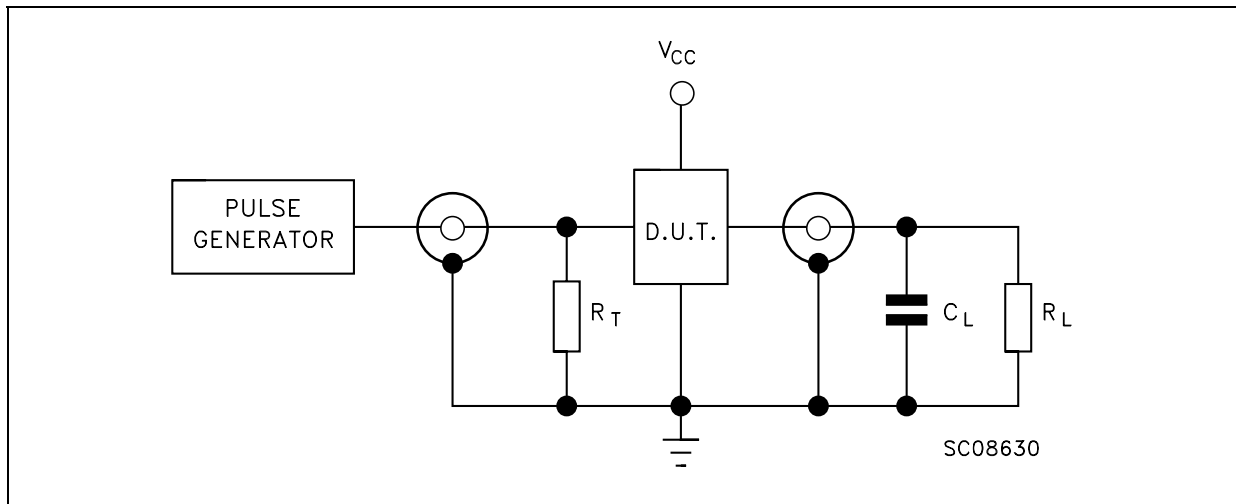

$R_T = Z_{OUT}$ of pulse generator (typically 50Ω)

TEST CIRCUIT AND WAVEFORM SYMBOL VALUE

Symbol	V_{CC}		
	1.65 to 1.95V	2.3 to 2.7V	2.7 to 5.5V
C_L	15pF/30pF	15pF/30pF	15pF/50pF
R_L	1MΩ/1000Ω	500Ω	500Ω
V_{IH}	V_{CC}	V_{CC}	V_{CC}
V_M	$V_{CC}/2$	$V_{CC}/2$	$V_{CC}/2$
$t_r = t_f$	<2.0ns	<2.0ns	<2.5ns

WAVEFORM: PROPAGATION DELAY (f=1MHz; 50% duty cycle)

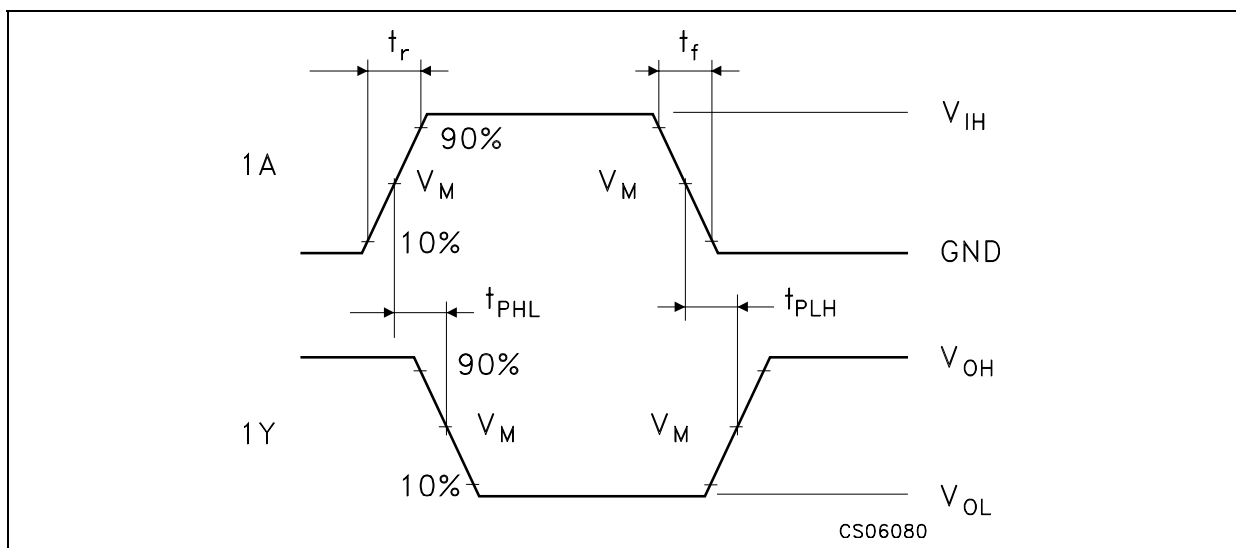
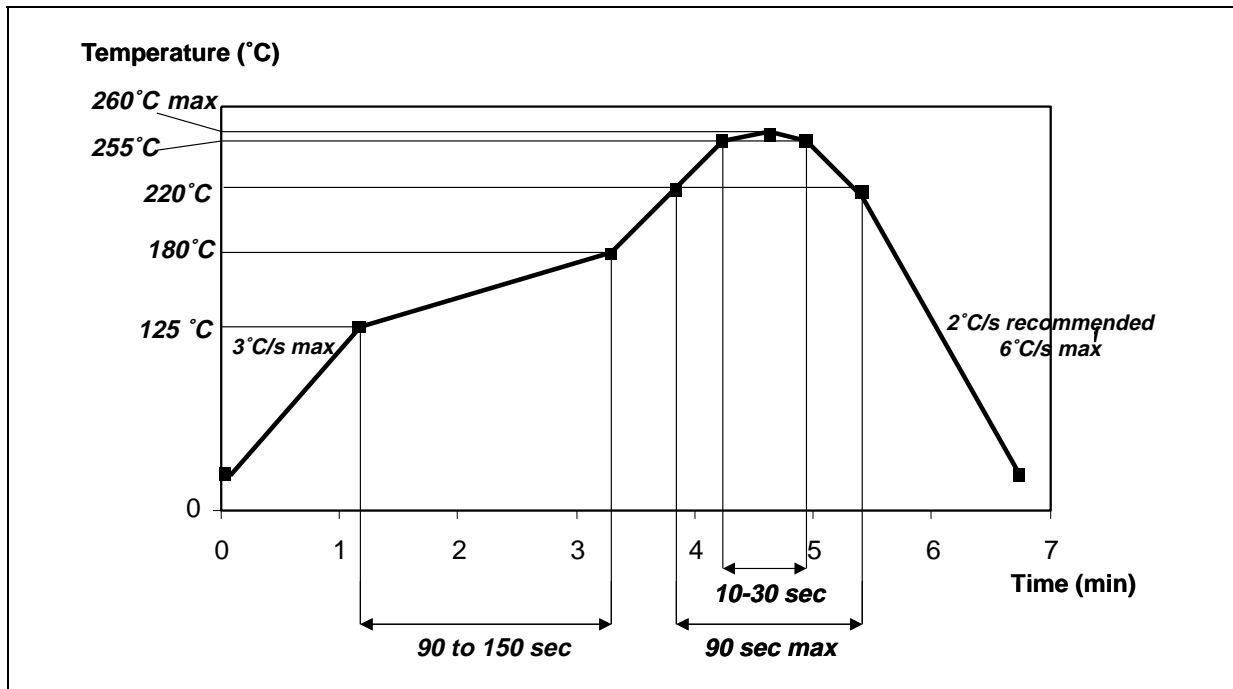

Figure 1 : RECOMMENDED SOLDERING REFLOW PROFILE FOR LEADFREE FLIP-CHIP MOUNTING ON PCB



For Flip-Chip mounting on the PCB, STMicroelectronics recommends the use of a solder stencil aperture of $330 \times 330 \mu\text{m}^2$ maximum and a typical stencil thickness of $125 \mu\text{m}$. Flip-Chips are fully compatible with the use of near eutectic 95.5Sn 4Ag 0.5Cu solder paste with no clean flux. ST's recommendations for Flip-Chip board mounting are illustrated on the soldering reflow profile shown in figure 1 below. Dwell time in the soldering zone (with temperature higher than 220°C) has to be kept as short as possible to prevent component and substrate damages. Peak temperature must not exceed 260°C . Controlled atmosphere (N_2 or N_2H_2) is recommended during the whole reflow, specially above 150°C . Flip-Chips are able to withstand three times the previous recommended reflow profile in order to be compatible with a double reflow when SMDs are mounted on both sides of the PCB plus one additional repair. A maximum of three soldering reflows are allowed for these leadfree packages (with repair step included). The use of a no clean flux is highly recommended to avoid any cleaning operation. In order to prevent any bump cracks, ultrasonic cleaning methods are not recommended.

SOT23-5L MECHANICAL DATA

DIM.	mm.			mils		
	MIN.	TYP.	MAX.	MIN.	TYP.	MAX.
A	0.90		1.45	35.4		57.1
A1	0.00		0.10	0.0		3.9
A2	0.90		1.30	35.4		51.2
b	0.35		0.50	13.7		19.7
C	0.09		0.20	3.5		7.8
D	2.80		3.00	110.2		118.1
E	1.50		1.75	59.0		68.8
e		0.95			37.4	
H	2.60		3.00	102.3		118.1
L	0.10		0.60	3.9		23.6

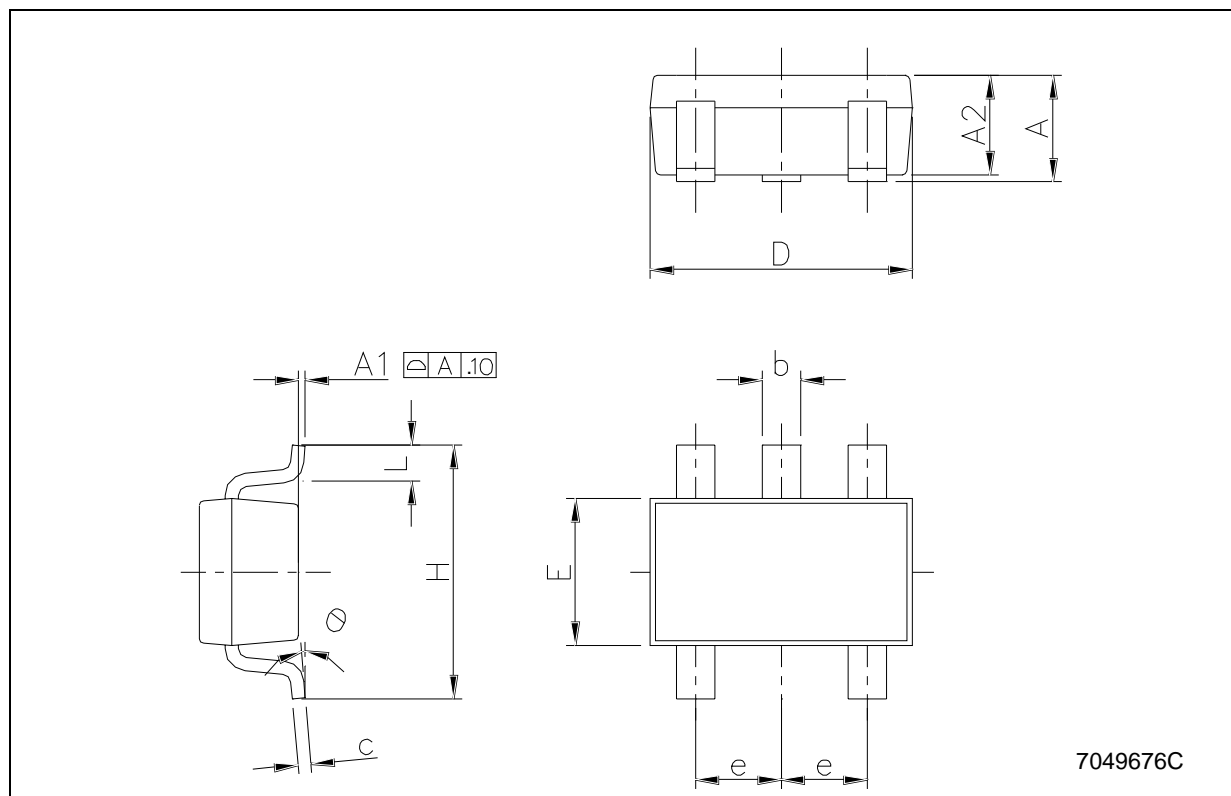

SOT323-5L MECHANICAL DATA

DIM.	mm.			mils		
	MIN.	TYP.	MAX.	MIN.	TYP.	MAX.
A	0.80		1.10	31.5		43.3
A1	0.00		0.10	0.0		3.9
A2	0.80		1.00	31.5		39.4
b	0.15		0.30	5.9		11.8
C	0.10		0.18	3.9		7.1
D	1.80		2.20	70.9		86.6
E	1.80		2.40	70.9		94.5
E1	1.15		1.35	45.3		53.1
e		0.65			25.6	
e1		1.3			51.2	
L	0.10		0.30	3.9		11.8

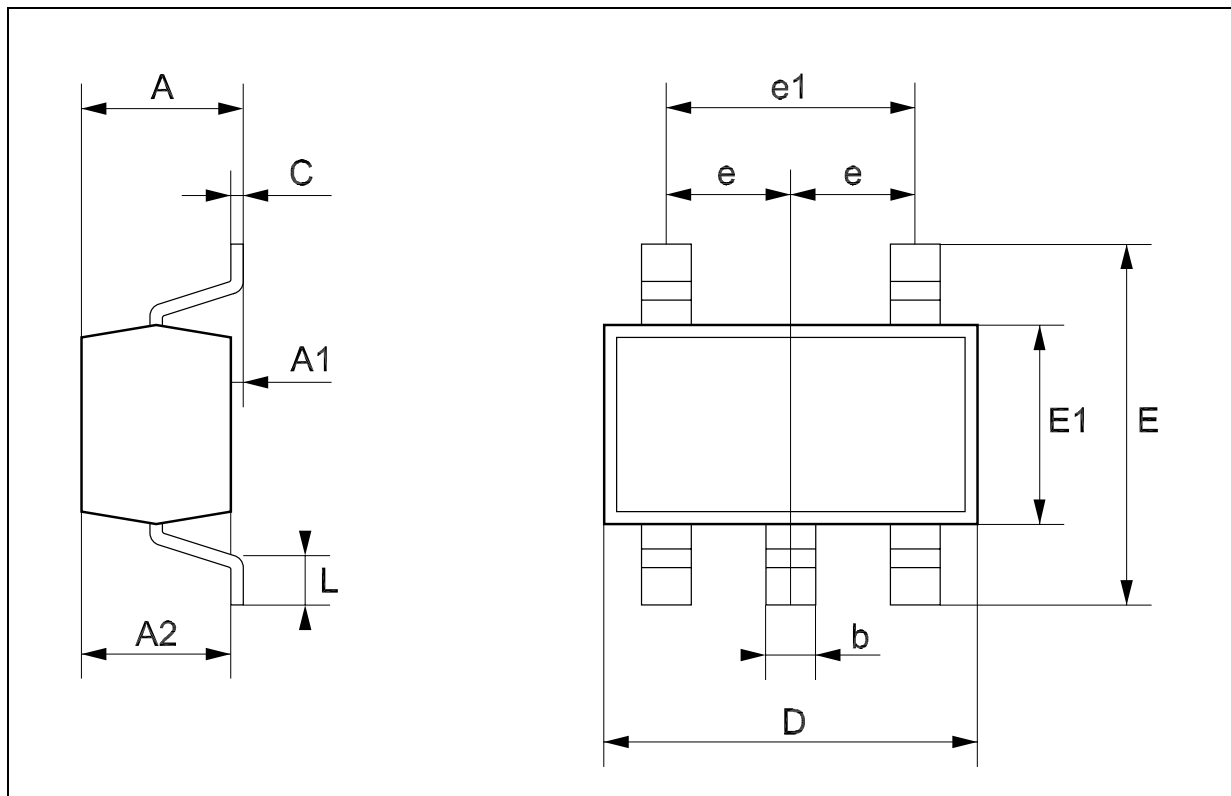

Flip-Chip4 MECHANICAL DATA

DIM.	mm.			mils		
	MIN.	TYP	MAX.	MIN.	TYP.	MAX.
A	0.585	0.65	0.715	23.03	25.59	28.15
A1	0.21	0.25	0.29	8.27	9.84	11.42
A2		0.40			15.75	
b	0.265	0.315	0.365	10.43	12.40	14.37
D	1.02	1.07	1.12	40.15	42.13	44.09
D1		0.5			19.69	
E	1.02	1.07	1.12	40.15	42.13	44.09
E1		0.5			19.69	

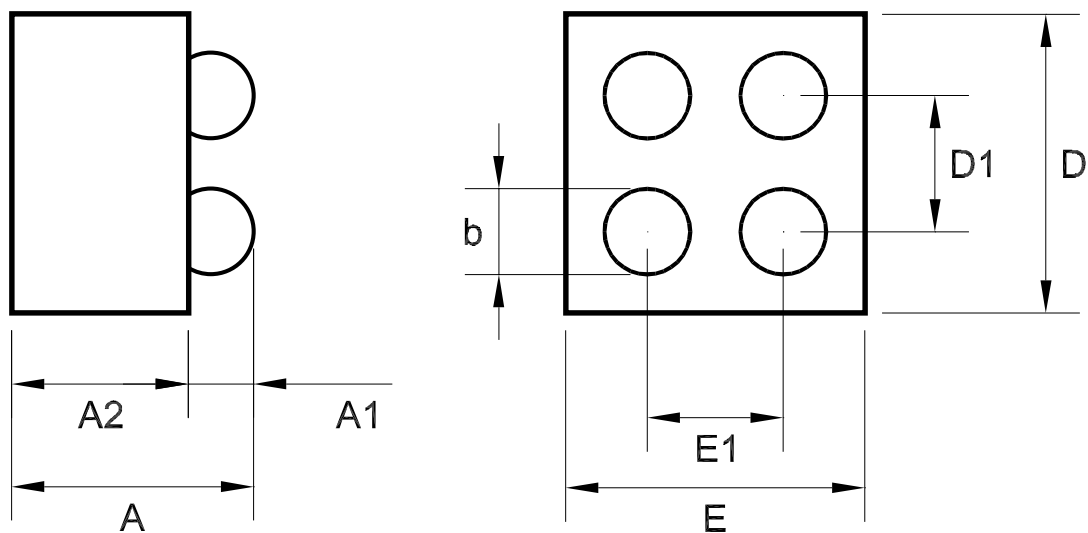

7224716/D

Tape & Reel SOT23-xL MECHANICAL DATA

DIM.	mm.			inch		
	MIN.	TYP	MAX.	MIN.	TYP.	MAX.
A			180			7.086
C	12.8	13.0	13.2	0.504	0.512	0.519
D	20.2			0.795		
N	60			2.362		
T			14.4			0.567
Ao	3.13	3.23	3.33	0.123	0.127	0.131
Bo	3.07	3.17	3.27	0.120	0.124	0.128
Ko	1.27	1.37	1.47	0.050	0.054	0.058
Po	3.9	4.0	4.1	0.153	0.157	0.161
P	3.9	4.0	4.1	0.153	0.157	0.161

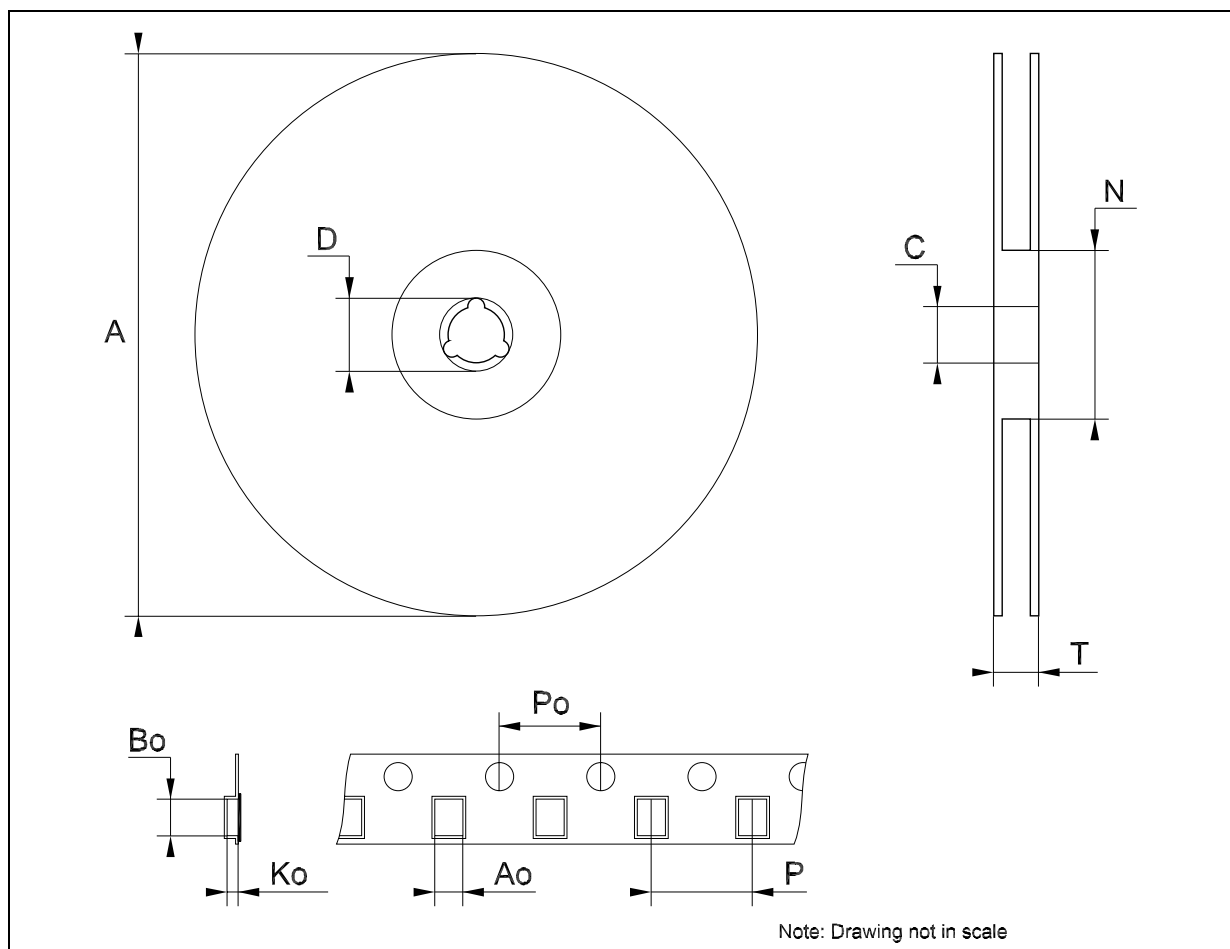

Tape & Reel SOT323-xL MECHANICAL DATA

DIM.	mm.			inch		
	MIN.	TYP	MAX.	MIN.	TYP.	MAX.
A	175	180	185	6.889	7.086	7.283
C	12.8	13	13.2	0.504	0.512	0.519
D	20.2			0.795		
N	59.5	60	60.5		2.362	
T			14.4			0.567
Ao		2.25			0.088	
Bo		2.7			0.106	
Ko		1.2			0.047	
Po	3.9	4	4.1	0.153	0.157	0.161
P	3.8	4	4.2	0.149	0.157	0.165

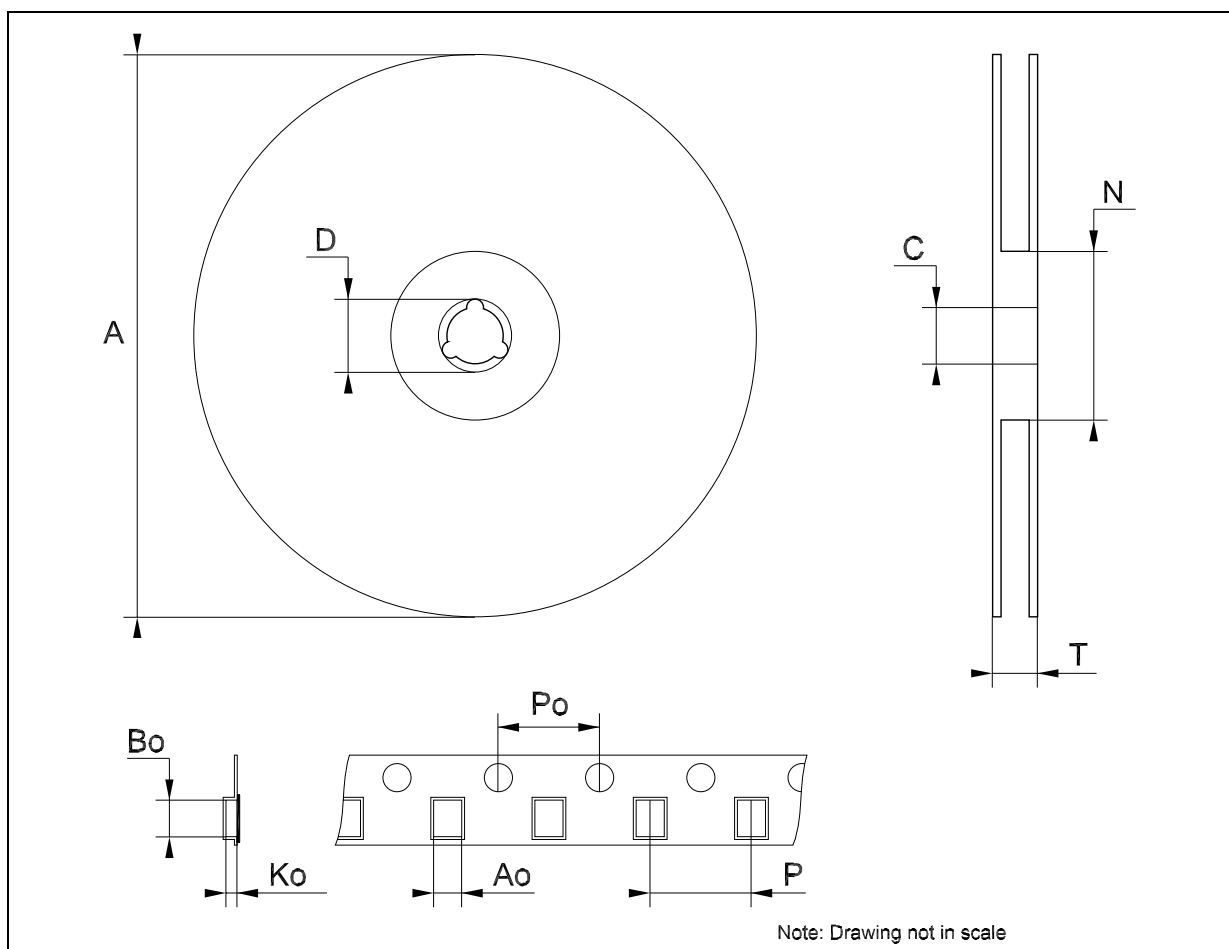

Tape & Reel Flip-Chip 4 MECHANICAL DATA

DIM.	mm.			inch		
	MIN.	TYP	MAX.	MIN.	TYP.	MAX.
A			178			6.926
C	12.8		13.2	0.504		0.519
D	20.2			0.795		
N	59	60	61	2.323	2.362	2.401
T			8.4			0.331
Ao	1.12	1.17	1.22	0.044	0.046	0.048
Bo	1.12	1.17	1.22	0.044	0.046	0.048
Ko	0.68	0.73	0.78	0.027	0.029	0.031
Po	3.9	4	4.1	0.153	0.157	0.161
P	3.9	4	4.1	0.153	0.157	0.161

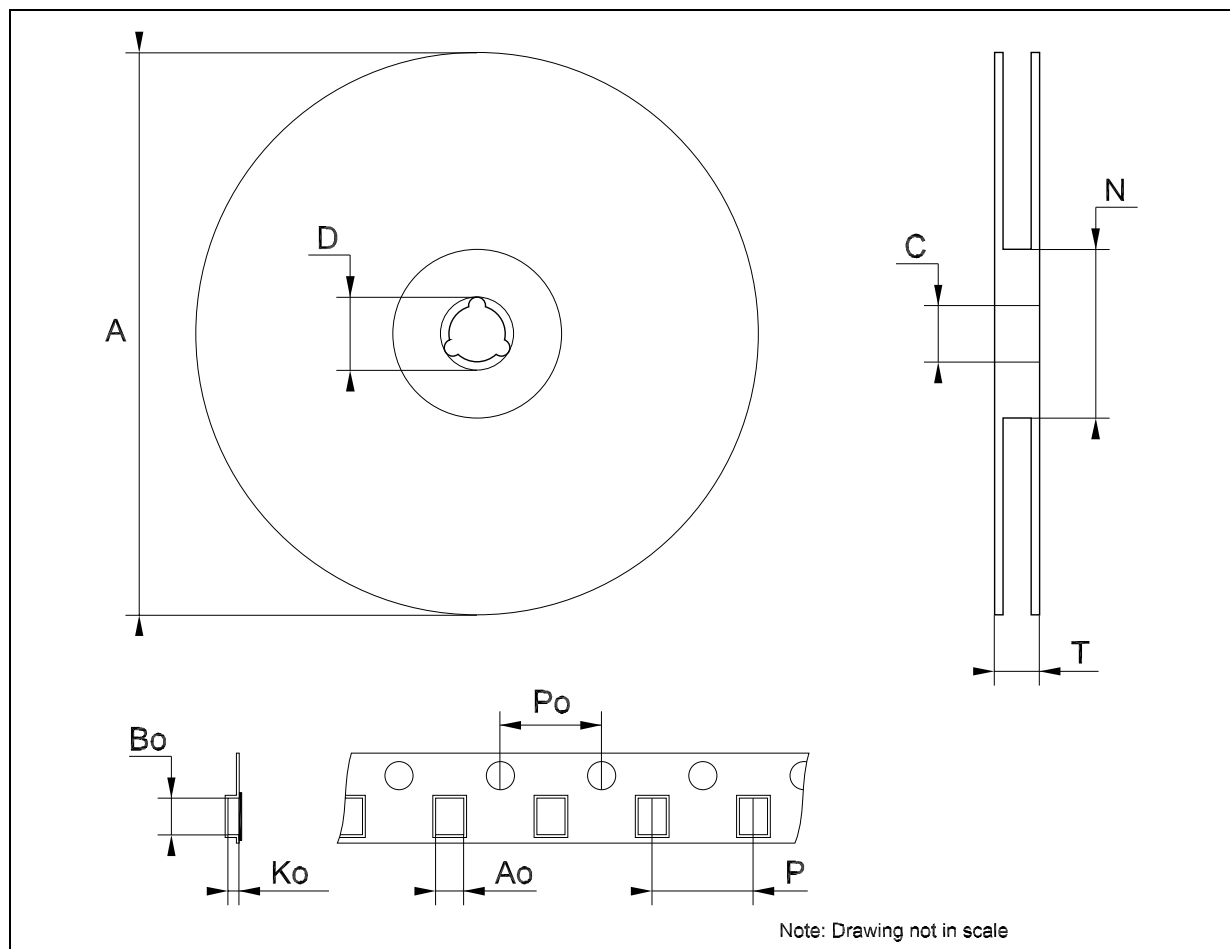

Information furnished is believed to be accurate and reliable. However, STMicroelectronics assumes no responsibility for the consequences of use of such information nor for any infringement of patents or other rights of third parties which may result from its use. No license is granted by implication or otherwise under any patent or patent rights of STMicroelectronics. Specifications mentioned in this publication are subject to change without notice. This publication supersedes and replaces all information previously supplied. STMicroelectronics products are not authorized for use as critical components in life support devices or systems without express written approval of STMicroelectronics.

The ST logo is a registered trademark of STMicroelectronics
All other names are the property of their respective owners

© 2004 STMicroelectronics - All Rights Reserved
STMicroelectronics GROUP OF COMPANIES

Australia - Belgium - Brazil - Canada - China - Czech Republic - Finland - France - Germany - Hong Kong - India - Israel - Italy - Japan -
Malaysia - Malta - Morocco - Singapore - Spain - Sweden - Switzerland - United Kingdom - United States.

<http://www.st.com>



Looking for pricing, stock, or lifecycle information?

Click below to explore more details on WIN SOURCE:

 [View 74LX1G04STR](#) on WIN SOURCE

 [STMicroelectronics](#) Information

Optimize Your Supply Chain with WIN SOURCE Solutions

-  Global Sourcing Solution
-  Obsolete Management
-  Cost Control Management
-  Shortage Management
-  Alternative Solution
-  Excess Inventory Management