

## Low Power, Stereo DAC w/Headphone & Speaker Amps

### FEATURES

- ◆ 98 dB Dynamic Range (A-wtd)
- ◆ 88 dB THD+N
- ◆ Headphone Amplifier - GND Centered
  - No DC-Blocking Capacitors Required
  - Integrated Negative Voltage Regulator
  - 2 x 23 mW into Stereo 16 Ω @ 1.8 V
  - 2 x 44 mW into Stereo 16 Ω @ 2.5V
- ◆ Stereo Analog Input Passthrough Architecture
  - Analog Input Mixing
  - Analog Passthrough with Volume Control
- ◆ Digital Signal Processing Engine
  - Bass & Treble Tone Control, De-Emphasis
  - PCM Input w/Independent Vol Control
  - Master Digital Volume Control and Limiter
  - Soft-Ramp & Zero-Cross Transitions
- ◆ Programmable Peak-Detect and Limiter
- ◆ Beep Generator w/Full Tone Control
  - Tone Selections Across Two Octaves
  - Separate Volume Control
  - Programmable On and Off Time Intervals
  - Continuous, Periodic, One-Shot Beep Selections

### Class D Stereo/Mono Speaker Amplifier

- ◆ No External Filter Required
- ◆ High Stereo Output Power at 10% THD+N
  - 2 x 1.00 W into 8 Ω @ 5.0 V
  - 2 x 550 mW into 8 Ω @ 3.7 V
  - 2 x 230 mW into 8 Ω @ 2.5 V
- ◆ High Mono Output Power at 10% THD+N
  - 1 x 1.90 W into 4 Ω @ 5.0 V
  - 1 x 1.00 W into 4 Ω @ 3.7 V
  - 1 x 350 mW into 4 Ω @ 2.5 V
- ◆ Direct Battery Powered Operation
  - Battery Level Monitoring & Compensation
- ◆ 81% Efficiency at 800 mW
- ◆ Phase-Aligned PWM Output Reduces Idle Channel Current
- ◆ Spread Spectrum Modulation
- ◆ Low Quiescent Current

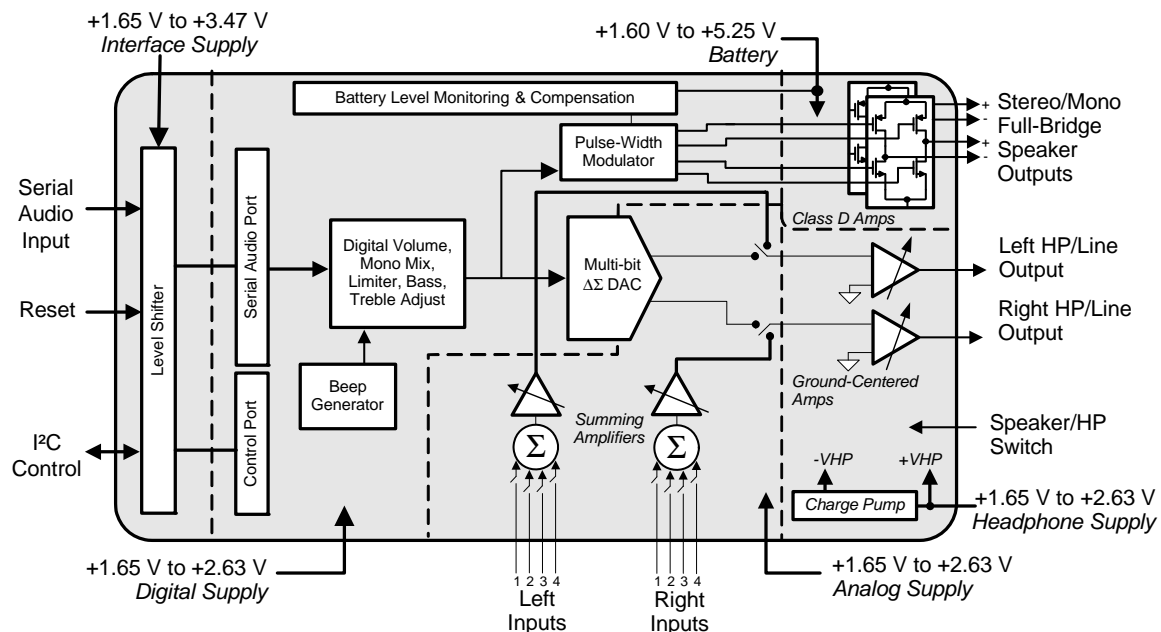

## System Features

- ◆ 12, 24, and 27 MHz Master Clock Support in Addition to Typical Audio Clock Rates
- ◆ High Performance 24-bit Converters
  - Multi-bit Delta–Sigma Architecture
  - Very Low 64Fs Oversampling Clock Reduces Power Consumption
- ◆ Low Power Operation
  - Stereo Analog Passthrough: 10 mW @ 1.8 V
  - Stereo Playback: 14 mW @ 1.8 V
- ◆ Variable Power Supplies
  - 1.8 V to 2.5 V Digital & Analog
  - 1.6 V to 5 V Class D Amplifier
  - 1.8 V to 2.5 V Headphone Amplifier
  - 1.8 V to 3.3 V Interface Logic
- ◆ Power Down Management
  - DAC, Passthrough Amplifier, Headphone Amplifier, Speaker Amplifier
- ◆ Flexible Clocking Options
  - Master or Slave Operation
  - Quarter-Speed Mode - (i.e. allows 8 kHz Fs while maintaining a flat noise floor up to 16 kHz)
  - 4 kHz to 96 kHz Sample Rates
- ◆ I<sup>2</sup>C™ Control Port Operation
- ◆ Headphone/Speaker Detection Input
- ◆ Pop and Click Suppression
- ◆ Pin-Compatible w/CS42L52

## Applications

- ◆ PDA's
- ◆ Personal Media Players
- ◆ Portable Game Consoles

## General Description

The CS43L22 is a highly integrated, low power stereo DAC with headphone and Class D speaker amplifiers. The CS43L22 offers many features suitable for low power, portable system applications.

The **DAC output path** includes a digital signal processing engine with various fixed function controls. Tone Control provides bass and treble adjustment of four selectable corner frequencies. Digital Volume controls may be configured to change on soft ramp transitions while the analog controls can be configured to occur on every zero crossing. The DAC also includes de-emphasis, limiting functions and a BEEP generator delivering tones selectable across a range of two full octaves.

The **stereo headphone amplifier** is powered from a separate positive supply and the integrated **charge pump** provides a negative supply. This allows a ground-centered analog output with a wide signal swing and eliminates the need for external DC-blocking capacitors.

The **Class D stereo speaker amplifier** does not require an external filter and provides the high efficiency amplification required by power sensitive portable applications. The speaker amplifier may be powered directly from a battery while the internal DC supply monitoring and compensation provides a constant gain level as the battery's voltage decays.

The CS43L22 accommodates analog routing of the analog input signal directly to the headphone amplifier. This feature is useful in applications that utilize an FM tuner where audio recovered over-the-air must be transmitted to the headphone amplifier directly.

In addition to its many features, the CS43L22 operates from a low voltage analog and digital core making it ideal for portable systems that require extremely low power consumption in a minimal amount of space.

The CS43L22 is available in a 40-pin QFN package in Commercial (-40 to +85 °C) grade. The CS43L22 Customer Demonstration board is also available for device evaluation and implementation suggestions. Please refer to ["Ordering Information" on page 66](#) for complete ordering information.

---

**TABLE OF CONTENTS**

<b>1. PIN DESCRIPTIONS</b> .....	<b>7</b>
1.1 I/O Pin Characteristics .....	8
<b>2. TYPICAL CONNECTION DIAGRAM</b> .....	<b>9</b>
<b>3. CHARACTERISTIC AND SPECIFICATIONS</b> .....	<b>10</b>
RECOMMENDED OPERATING CONDITIONS .....	10
ABSOLUTE MAXIMUM RATINGS .....	10
ANALOG OUTPUT CHARACTERISTICS .....	11
ANALOG PASSTHROUGH CHARACTERISTICS .....	12
PWM OUTPUT CHARACTERISTICS .....	13
HEADPHONE OUTPUT POWER CHARACTERISTICS .....	14
LINE OUTPUT VOLTAGE LEVEL CHARACTERISTICS .....	15
COMBINED DAC INTERPOLATION & ON-CHIP ANALOG FILTER RESPONSE .....	15
SWITCHING SPECIFICATIONS - SERIAL PORT .....	16
SWITCHING SPECIFICATIONS - I <sup>2</sup> C CONTROL PORT .....	17
DC ELECTRICAL CHARACTERISTICS .....	18
DIGITAL INTERFACE SPECIFICATIONS & CHARACTERISTICS .....	18
POWER CONSUMPTION .....	19
<b>4. APPLICATIONS</b> .....	<b>20</b>
4.1 Overview .....	20
4.1.1 Basic Architecture .....	20
4.1.2 Line Inputs .....	20
4.1.3 Line & Headphone Outputs .....	20
4.1.4 Speaker Driver Outputs .....	20
4.1.5 Fixed Function DSP Engine .....	20
4.1.6 Beep Generator .....	20
4.1.7 Power Management .....	20
4.2 DSP Engine .....	21
4.2.1 Beep Generator .....	22
4.2.2 Limiter .....	22
4.3 Analog Passthrough .....	24
4.4 Analog Outputs .....	25
4.5 PWM Outputs .....	26
4.5.1 Mono Speaker Output Configuration .....	27
4.5.2 VP Battery Compensation .....	27
4.5.2.1 Maintaining a Desired Output Level .....	27
4.6 Serial Port Clocking .....	29
4.7 Digital Interface Formats .....	30
4.7.1 DSP Mode .....	31
4.8 Initialization .....	31
4.9 Recommended Power-Up Sequence .....	31
4.10 Recommended Power-Down Sequence .....	31
4.11 Required Initialization Settings .....	32
<b>5. CONTROL PORT OPERATION</b> .....	<b>33</b>
5.1 I <sup>2</sup> C Control .....	33
5.1.1 Memory Address Pointer (MAP) .....	34
5.1.1.1 Map Increment (INCR) .....	34
<b>6. REGISTER QUICK REFERENCE</b> .....	<b>35</b>
<b>7. REGISTER DESCRIPTION</b> .....	<b>37</b>
7.1 Chip I.D. and Revision Register (Address 01h) (Read Only) .....	37
7.1.1 Chip I.D. (Read Only) .....	37
7.1.2 Chip Revision (Read Only) .....	37
7.2 Power Control 1 (Address 02h) .....	37

7.2.1 Power Down .....	37
7.3 Power Control 2 (Address 04h) .....	38
7.3.1 Headphone Power Control .....	38
7.3.2 Speaker Power Control .....	38
7.4 Clocking Control (Address 05h) .....	38
7.4.1 Auto-Detect .....	38
7.4.2 Speed Mode .....	39
7.4.3 32kHz Sample Rate Group .....	39
7.4.4 27 MHz Video Clock .....	39
7.4.5 Internal MCLK/LRCK Ratio .....	39
7.4.6 MCLK Divide By 2 .....	40
7.5 Interface Control 1 (Address 06h) .....	40
7.5.1 Master/Slave Mode .....	40
7.5.2 SCLK Polarity .....	40
7.5.3 DSP Mode .....	40
7.5.4 DAC Interface Format .....	40
7.5.5 Audio Word Length .....	41
7.6 Interface Control 2 (Address 07h) .....	41
7.6.1 SCLK equals MCLK .....	41
7.6.2 Speaker/Headphone Switch Invert .....	41
7.7 Passthrough x Select: PassA (Address 08h), PassB (Address 09h) .....	42
7.7.1 Passthrough Input Channel Mapping .....	42
7.8 Analog ZC and SR Settings (Address 0Ah) .....	42
7.8.1 Ch. x Analog Soft Ramp .....	42
7.8.2 Ch. x Analog Zero Cross .....	42
7.9 Passthrough Gang Control (Address 0Ch) .....	42
7.9.1 Passthrough Channel B=A gang Control .....	42
7.10 Playback Control 1 (Address 0Dh) .....	43
7.10.1 Headphone Analog Gain .....	43
7.10.2 Playback Volume Setting B=A .....	43
7.10.3 Invert PCM Signal Polarity .....	43
7.10.4 Master Playback Mute .....	43
7.11 Miscellaneous Controls (Address 0Eh) .....	44
7.11.1 Passthrough Analog .....	44
7.11.2 Passthrough Mute .....	44
7.11.3 Freeze Registers .....	44
7.11.4 HP/Speaker De-Emphasis .....	44
7.11.5 Digital Soft Ramp .....	44
7.11.6 Digital Zero Cross .....	45
7.12 Playback Control 2 (Address 0Fh) .....	45
7.12.1 Headphone Mute .....	45
7.12.2 Speaker Mute .....	45
7.12.3 Speaker Volume Setting B=A .....	45
7.12.4 Speaker Channel Swap .....	45
7.12.5 Speaker MONO Control .....	46
7.12.6 Speaker Mute 50/50 Control .....	46
7.13 Passthrough x Volume: PASSAVOL (Address 14h) & PASSBVOL (Address 15h) .....	46
7.13.1 Passthrough x Volume .....	46
7.14 PCMx Volume: PCMA (Address 1Ah) & PCMB (Address 1Bh) .....	47
7.14.1 PCM Channel x Mute .....	47
7.14.2 PCM Channel x Volume .....	47
7.15 Beep Frequency & On Time (Address 1Ch) .....	47
7.15.1 Beep Frequency .....	47
7.15.2 Beep On Time .....	48

7.16 Beep Volume & Off Time (Address 1Dh) .....	48
7.16.1 Beep Off Time .....	48
7.16.2 Beep Volume .....	49
7.17 Beep & Tone Configuration (Address 1Eh) .....	49
7.17.1 Beep Configuration .....	49
7.17.2 Beep Mix Disable .....	49
7.17.3 Treble Corner Frequency .....	50
7.17.4 Bass Corner Frequency .....	50
7.17.5 Tone Control Enable .....	50
7.18 Tone Control (Address 1Fh) .....	50
7.18.1 Treble Gain .....	50
7.18.2 Bass Gain .....	51
7.19 Master Volume Control: MSTA (Address 20h) & MSTB (Address 21h) .....	51
7.19.1 Master Volume Control .....	51
7.20 Headphone Volume Control: HPA (Address 22h) & HPB (Address 23h) .....	51
7.20.1 Headphone Volume Control .....	51
7.21 Speaker Volume Control: SPKA (Address 24h) & SPKB (Address 25h) .....	52
7.21.1 Speaker Volume Control .....	52
7.22 PCM Channel Swap (Address 26h) .....	52
7.22.1 PCM Channel Swap .....	52
7.23 Limiter Control 1, Min/Max Thresholds (Address 27h) .....	53
7.23.1 Limiter Maximum Threshold .....	53
7.23.2 Limiter Cushion Threshold .....	53
7.23.3 Limiter Soft Ramp Disable .....	53
7.23.4 Limiter Zero Cross Disable .....	54
7.24 Limiter Control 2, Release Rate (Address 28h) .....	54
7.24.1 Peak Detect and Limiter .....	54
7.24.2 Peak Signal Limit All Channels .....	54
7.24.3 Limiter Release Rate .....	54
7.25 Limiter Attack Rate (Address 29h) .....	55
7.25.1 Limiter Attack Rate .....	55
7.26 Status (Address 2Eh) (Read Only) .....	55
7.26.1 Serial Port Clock Error (Read Only) .....	55
7.26.2 DSP Engine Overflow (Read Only) .....	55
7.26.3 PCMx Overflow (Read Only) .....	56
7.27 Battery Compensation (Address 2Fh) .....	56
7.27.1 Battery Compensation .....	56
7.27.2 VP Monitor .....	56
7.27.3 VP Reference .....	57
7.28 VP Battery Level (Address 30h) (Read Only) .....	57
7.28.1 VP Voltage Level (Read Only) .....	57
7.29 Speaker Status (Address 31h) (Read Only) .....	57
7.29.1 Speaker Current Load Status (Read Only) .....	57
7.29.2 SPKR/HP Pin Status (Read Only) .....	58
7.30 Charge Pump Frequency (Address 34h) .....	58
7.30.1 Charge Pump Frequency .....	58
<b>8. ANALOG PERFORMANCE PLOTS .....</b>	<b>59</b>
8.1 Headphone THD+N versus Output Power Plots .....	59
<b>9. EXAMPLE SYSTEM CLOCK FREQUENCIES .....</b>	<b>61</b>
9.1 Auto Detect Enabled .....	61
9.2 Auto Detect Disabled .....	61
<b>10. PCB LAYOUT CONSIDERATIONS .....</b>	<b>62</b>
10.1 Power Supply, Grounding .....	62
10.2 QFN Thermal Pad .....	62

<b>11. DIGITAL FILTER PLOTS .....</b>	<b>63</b>
<b>12. PARAMETER DEFINITIONS .....</b>	<b>64</b>
<b>13. PACKAGE DIMENSIONS .....</b>	<b>65</b>
THERMAL CHARACTERISTICS .....	65
<b>14. ORDERING INFORMATION .....</b>	<b>66</b>
<b>15. REFERENCES .....</b>	<b>66</b>
<b>16. REVISION HISTORY .....</b>	<b>66</b>

## LIST OF FIGURES

Figure 1. Typical Connection Diagram .....	9
Figure 2. Headphone Output Test Load .....	14
Figure 3. Serial Audio Interface Timing .....	16
Figure 4. Control Port Timing - I <sup>2</sup> C .....	17
Figure 5. DSP Engine Signal Flow .....	21
Figure 6. Beep Configuration Options .....	22
Figure 7. Peak Detect & Limiter .....	23
Figure 8. Analog Passthrough Signal Flow .....	24
Figure 9. Analog Outputs .....	25
Figure 10. PWM Output Stage .....	26
Figure 11. Battery Compensation .....	28
Figure 12. I <sup>2</sup> S Format .....	30
Figure 13. Left-Justified Format .....	30
Figure 14. Right-Justified Format\ .....	30
Figure 15. DSP Mode Format) .....	31
Figure 16. Control Port Timing, I <sup>2</sup> C Write .....	33
Figure 17. Control Port Timing, I <sup>2</sup> C Read .....	33
Figure 18. THD+N vs. Output Power per Channel at 1.8 V (16 Ω load) .....	59
Figure 19. THD+N vs. Output Power per Channel at 2.5 V (16 Ω load) .....	59
Figure 20. THD+N vs. Output Power per Channel at 1.8 V (32 Ω load) .....	60
Figure 21. THD+N vs. Output Power per Channel at 2.5 V (32 Ω load) .....	60
Figure 22. Passband Ripple .....	63
Figure 23. Stopband .....	63
Figure 24. DAC Transition Band .....	63
Figure 25. Transition Band (Detail) .....	63

# 1. PIN DESCRIPTIONS

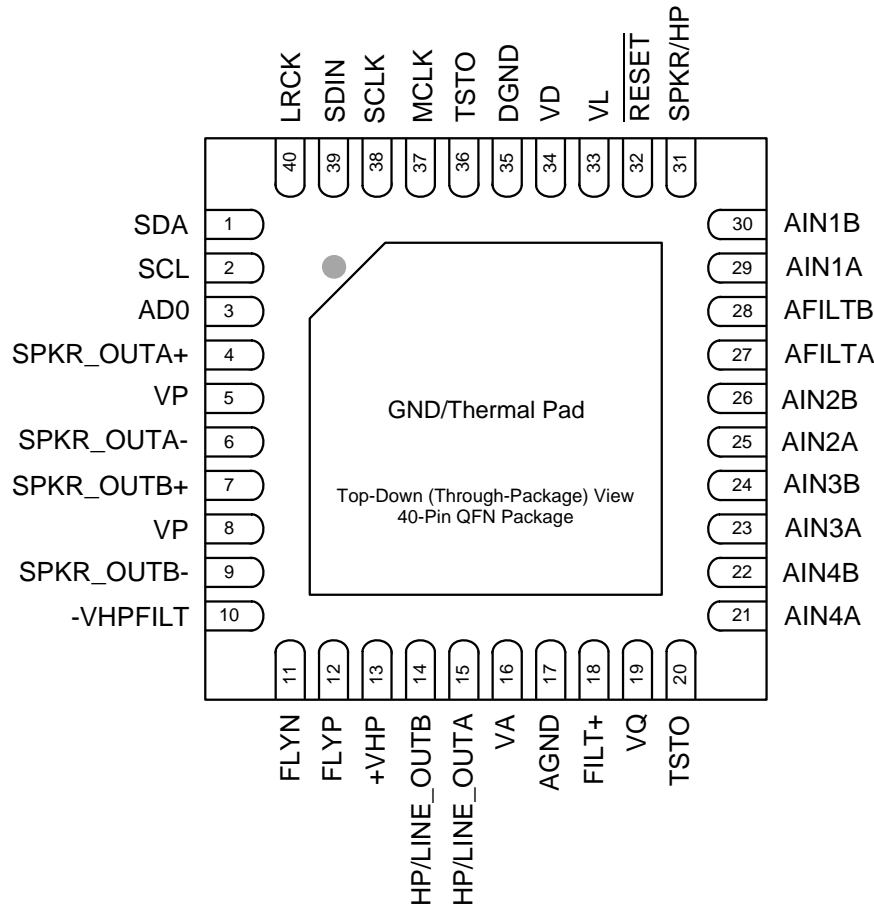

Pin Name	#	Pin Description
SDA	1	<b>Serial Control Data</b> ( <i>Input/Output</i> ) - SDA is a data I/O in I <sup>2</sup> C Mode.
SCL	2	<b>Serial Control Port Clock</b> ( <i>Input</i> ) - Serial clock for the serial control port.
AD0	3	<b>Address Bit 0 (I<sup>2</sup>C)</b> ( <i>Input</i> ) - AD0 is a chip address pin in I <sup>2</sup> C Mode.
SPKR_OUTA+	4	<b>PWM Speaker Output</b> ( <i>Output</i> ) - Full-bridge amplified PWM speaker outputs.
SPKR_OUTA-	6	
SPKR_OUTB+	7	
SPKR_OUTB-	9	
VP	5 8	<b>Power for PWM Drivers</b> ( <i>Input</i> ) - Power supply for the PWM output driver stages.
-VHPFILT	10	<b>Inverting Charge Pump Filter Connection</b> ( <i>Output</i> ) - Power supply from the inverting charge pump that provides the negative rail for the headphone/line amplifiers.
FLYN	11	<b>Charge Pump Cap Negative Node</b> ( <i>Output</i> ) - Negative node for the inverting charge pump's flying capacitor.
FLYP	12	<b>Charge Pump Cap Positive Node</b> ( <i>Output</i> ) - Positive node for the inverting charge pump's flying capacitor.
+VHP	13	<b>Positive Analog Power for Headphone</b> ( <i>Input</i> ) - Positive voltage rail and power for the internal headphone amplifiers and inverting charge pump.
HP/LINE_OUTB, A	14,15	<b>Headphone/Line Audio Output</b> ( <i>Output</i> ) - Stereo headphone or line level analog outputs.
VA	16	<b>Analog Power</b> ( <i>Input</i> ) - Positive power for the internal analog section.

AGND	17	<b>Analog Ground</b> ( <i>Input</i> ) - Ground reference for the internal analog section.
FILT+	18	<b>Positive Voltage Reference</b> ( <i>Output</i> ) - Filter connection for the internal sampling circuits.
VQ	19	<b>Quiescent Voltage</b> ( <i>Output</i> ) - Filter connection for the internal quiescent voltage.
TSTO	20,36	<b>Test Out</b> ( <i>Output</i> ) - This pin is an output used for test purposes only and must be left "floating" (no connection external to the pin).
AIN4A,B	21,22	<b>Line-Level Analog Inputs</b> ( <i>Input</i> ) - Single-ended stereo line-level analog inputs.
AIN3A,B	23,24	
AIN2A,B	25,26	
AIN1A,B	29,30	
AFILTA,AFILTB	27,28	<b>Anti-alias Filter Connection</b> ( <i>Output</i> ) - Anti-alias filter connection for analog passthrough mode.
SPKR/HP	31	<b>Speaker/Headphone Switch</b> ( <i>Input</i> ) - Powers down the left and/or right channel of the speaker and/or headphone outputs.
RESET	32	<b>Reset</b> ( <i>Input</i> ) - The device enters a low power mode when this pin is driven low.
VL	33	<b>Digital Interface Power</b> ( <i>Input</i> ) - Determines the required signal level for the serial audio interface and host control port.
VD	34	<b>Digital Power</b> ( <i>Input</i> ) - Positive power for the internal digital section.
DGND	35	<b>Digital Ground</b> ( <i>Input</i> ) - Ground reference for the internal digital section.
MCLK	37	<b>Master Clock</b> ( <i>Input</i> ) - Clock source for the delta-sigma modulators.
SCLK	38	<b>Serial Clock</b> ( <i>Input/Output</i> ) - Serial clock for the serial audio interface.
SDIN	39	<b>Serial Audio Data Input</b> ( <i>Input</i> ) - Input for two's complement serial audio data.
LRCK	40	<b>Left Right Clock</b> ( <i>Input/Output</i> ) - Determines which channel, Left or Right, is currently active on the serial audio data line.
GND/Thermal Pad	-	Ground reference for PWM power FETs and charge pump; thermal relief pad for optimized heat dissipation.

## 1.1 I/O Pin Characteristics

Input and output levels and associated power supply voltage are shown in the table below. Logic levels should not exceed the corresponding power supply voltage.

Power Supply	Pin Name	I/O	Internal Connections	Driver	Receiver
VL	RESET	Input	-	-	1.65 V - 3.47 V, with Hysteresis
	AD0	Input	-	-	1.65 V - 3.47 V, with Hysteresis
	SCL	Input	-	-	1.65 V - 3.47 V, with Hysteresis
	SDA	Input/Output	-	1.65 V - 3.47 V, CMOS/Open Drain	1.65 V - 3.47 V, with Hysteresis
	MCLK	Input	-	-	1.65 V - 3.47 V
	LRCK	Input/Output	Weak Pull-up (~1 M $\Omega$ )	1.65 V - 3.47 V, CMOS	1.65 V - 3.47 V
	SCLK	Input/Output	Weak Pull-up (~1 M $\Omega$ )	1.65 V - 3.47 V, CMOS	1.65 V - 3.47 V
	SDIN	Input	-	-	1.65 V - 3.47 V
VA	SPKR/HP	Input	-	-	1.65 V - 2.63 V
VP	SPKR_OUTA+	Output	-	1.6 V - 5.25 V Power MOSFET	-
	SPKR_OUTA-	Output	-	1.6 V - 5.25 V Power MOSFET	-
	SPKR_OUTB+	Output	-	1.6 V - 5.25 V Power MOSFET	-
	SPKR_OUTB-	Output	-	1.6 V - 5.25 V Power MOSFET	-

## 2. TYPICAL CONNECTION DIAGRAM

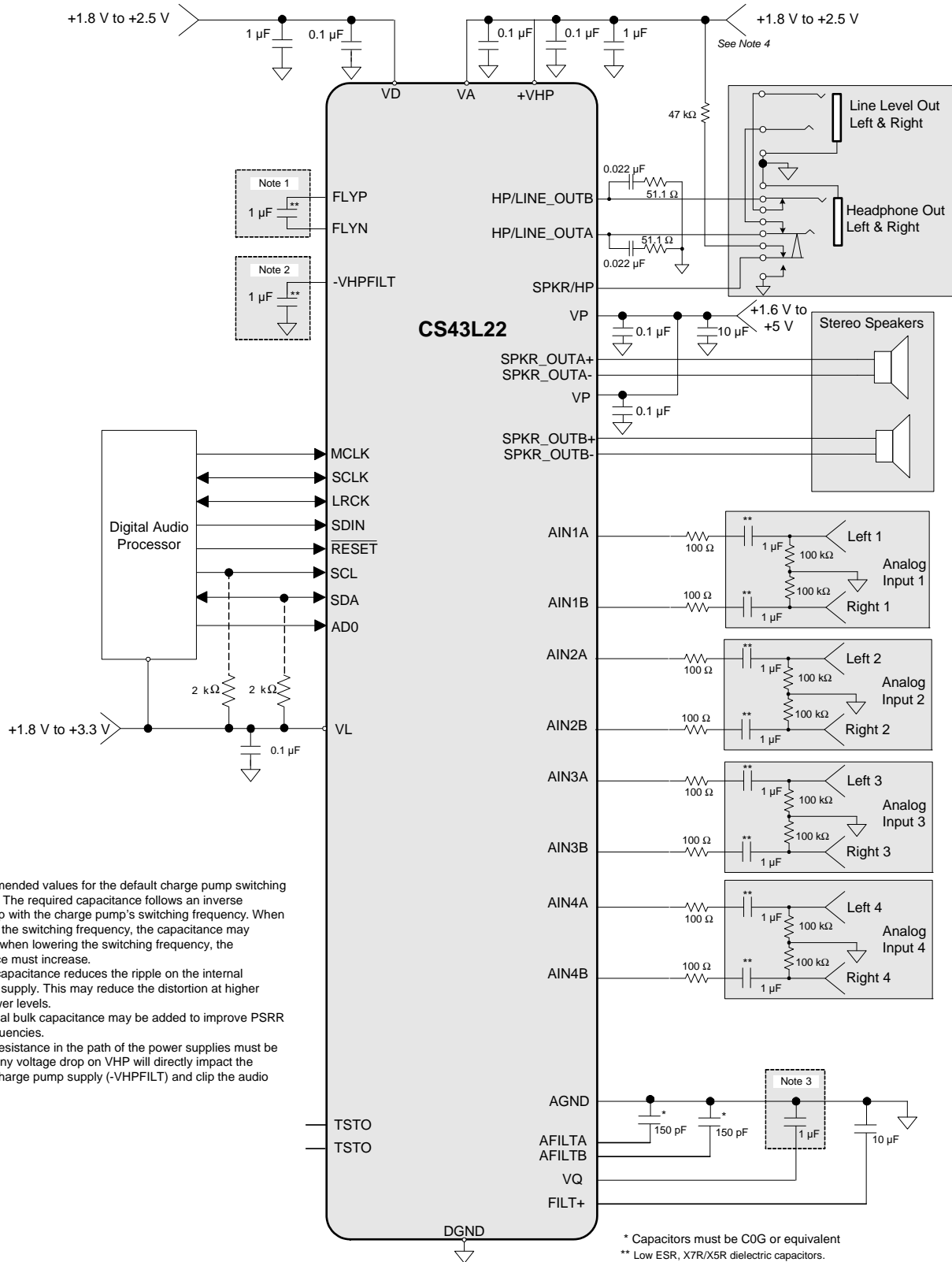

**Figure 1. Typical Connection Diagram**

### 3. CHARACTERISTIC AND SPECIFICATIONS

#### RECOMMENDED OPERATING CONDITIONS

AGND=DGND=0 V, all voltages with respect to ground.

Parameters	Symbol	Min	Max	Units
DC Power Supply				
Analog	VA	1.65	2.63	V
Headphone Amplifier	+VHP	1.65	2.63	V
Speaker Amplifier	VP	1.60	5.25	V
Digital	VD	1.65	2.63	V
Serial/Control Port Interface	VL	1.65	3.47	V
Ambient Temperature	Commercial T <sub>A</sub>	-40	+85	°C

#### ABSOLUTE MAXIMUM RATINGS

AGND = DGND = 0 V; all voltages with respect to ground.

Parameters	Symbol	Min	Max	Units
DC Power Supply	Analog VA, VHP	-0.3	3.0	V
	Speaker VP	-0.3	5.5	V
	Digital VD	-0.3	3.0	V
	Serial/Control Port Interface VL	-0.3	4.0	V
Input Current	(Note 1) I <sub>in</sub>	-	±10	mA
Analog Input Voltage	(Note 2) V <sub>IN</sub>	AGND-0.7	VA+0.7	V
External Voltage Applied to Analog Input	(Note 2) V <sub>IN</sub>	AGND-0.3	VA+0.3	V
External Voltage Applied to Analog Output	V <sub>IN</sub>	-VHP - 0.3	+VHP + 0.3	V
External Voltage Applied to Digital Input	(Note 2) V <sub>IND</sub>	-0.3	VL+ 0.3	V
Ambient Operating Temperature (power applied)	T <sub>A</sub>	-50	+115	°C
Storage Temperature	T <sub>stg</sub>	-65	+150	°C

**WARNING:** Operation at or beyond these limits may result in permanent damage to the device. Normal operation is not guaranteed at these extremes.

#### Notes:

- Any pin except supplies. Transient currents of up to ±100 mA on the analog input pins will not cause SCR latch-up.
- The maximum over/under voltage is limited by the input current.

## ANALOG OUTPUT CHARACTERISTICS

Test conditions (unless otherwise specified): Input test signal is a full-scale 997 Hz sine wave; All Supplies = VA; T<sub>A</sub> = +25°C; Sample Frequency = 48 kHz; Measurement bandwidth is 20 Hz to 20 kHz; Test load R<sub>L</sub> = 10 kΩ, C<sub>L</sub> = 10 pF for the line output (see [Figure 2](#)); Test load R<sub>L</sub> = 16 Ω, C<sub>L</sub> = 10 pF (see [Figure 2](#)) for the headphone output; HP\_GAIN[2:0] = 011.

Parameters (Note 3)		VA = 2.5 V			VA = 1.8 V			Unit
		Min	Typ	Max	Min	Typ	Max	
<b>R<sub>L</sub> = 10 kΩ</b>								
<b>Dynamic Range</b>								
18 to 24-Bit	A-weighted	92	98	-	89	95	-	dB
	unweighted	89	95	-	86	92	-	dB
16-Bit	A-weighted	-	96	-	-	93	-	dB
	unweighted	-	93	-	-	90	-	dB
<b>Total Harmonic Distortion + Noise</b>								
18 to 24-Bit	0 dB	-	-86	-80	-	-88	-82	dB
	-20 dB	-	-75	-	-	-72	-	dB
	-60 dB	-	-35	-29	-	-32	-26	dB
16-Bit	0 dB	-	-86	-	-	-88	-	dB
	-20 dB	-	-73	-	-	-70	-	dB
	-60 dB	-	-33	-	-	-30	-	dB
<b>R<sub>L</sub> = 16 Ω</b>								
<b>Dynamic Range</b>								
18 to 24-Bit	A-weighted	92	98	-	89	95	-	dB
	unweighted	89	95	-	86	92	-	dB
16-Bit	A-weighted	-	96	-	-	93	-	dB
	unweighted	-	93	-	-	90	-	dB
<b>Total Harmonic Distortion + Noise</b>								
18 to 24-Bit	0 dB	-	-75	-69	-	-75	-69	dB
	-20 dB	-	-75	-	-	-72	-	dB
	-60 dB	-	-35	-29	-	-32	-26	dB
16-Bit	0 dB	-	-75	-	-	-75	-	dB
	-20 dB	-	-73	-	-	-70	-	dB
	-60 dB	-	-33	-	-	-30	-	dB
<b>Other Characteristics for R<sub>L</sub> = 16 Ω or 10 kΩ</b>								
Output Parameters (Note 4)	Modulation Index (MI)	-	0.6787	-	-	0.6787	-	V/V
	Analog Gain Multiplier (G)	-	0.6047	-	-	0.6047	-	V/V
Full-scale Output Voltage (2•G•MI•VA) (Note 4)		Refer to Table "Headphone Output Power Characteristics" on page 14						V <sub>pp</sub>
Full-scale Output Power (Note 4)		Refer to Table "Headphone Output Power Characteristics" on page 14						
Interchannel Isolation (1 kHz)	16 Ω	-	80	-	-	80	-	dB
	10 kΩ	-	95	-	-	93	-	dB
Speaker Amp to HP Amp Isolation		-	80	-	-	80	-	dB
Interchannel Gain Mismatch		-	0.1	0.25	-	0.1	0.25	dB
Gain Drift		-	±100	-	-	±100	-	ppm/°C
AC-Load Resistance (R <sub>L</sub> )	(Note 5)	16	-	-	16	-	-	Ω
Load Capacitance (C <sub>L</sub> )	(Note 5)	-	-	150	-	-	150	pF

- One (least-significant bit) LSB of triangular PDF dither is added to data.
- Full-scale output voltage and power is determined by the gain setting, G, in register "Headphone Analog Gain" on page 43. High gain settings at certain VA and VHP supply levels may cause clipping when the audio signal approaches full-scale, maximum power output, as shown in [Figures 18 - 21 on page 60](#).

5. See Figure 2.  $R_L$  and  $C_L$  reflect the recommended minimum resistance and maximum capacitance required for the internal op-amp's stability and signal integrity. In this circuit topology,  $C_L$  will effectively move the band-limiting pole of the amp in the output stage. Increasing this value beyond the recommended 150 pF can cause the internal op-amp to become unstable.

## ANALOG PASSTHROUGH CHARACTERISTICS

Test Conditions (unless otherwise specified): Input sine wave (relative to full-scale): 1 kHz through passive input filter; Passthrough Amplifier and HP/Line Gain = 0 dB; All Supplies = VA;  $T_A = +25^\circ\text{C}$ ; Sample Frequency = 48 kHz; Measurement Bandwidth is 20 Hz to 20 kHz.

Parameters		VA = 2.5 V			VA = 1.8 V			Unit
		Min	Typ	Max	Min	Typ	Max	
<b>Analog In to HP/Line Amp</b>								
<b><math>R_L = 10\text{ k}\Omega</math></b>								
Dynamic Range	A-weighted	-	-96	-	-	-94	-	dB
	unweighted	-	-93	-	-	-91	-	dB
Total Harmonic Distortion + Noise	-1 dBFS	-	-70	-	-	-70	-	dB
	-20 dBFS	-	-73	-	-	-71	-	dB
	-60 dBFS	-	-33	-	-	-31	-	dB
Full-scale Input Voltage		-	$0.91 \cdot VA$	-	-	$0.91 \cdot VA$	-	Vpp
Full-scale Output Voltage		-	$0.84 \cdot VA$	-	-	$0.84 \cdot VA$	-	Vpp
Passband Ripple		-	0/-0.3	-	-	0/-0.3	-	dB
<b><math>R_L = 16\ \Omega</math></b>								
Dynamic Range	A-weighted	-	-96	-	-	-94	-	dB
	unweighted	-	-93	-	-	-91	-	dB
Total Harmonic Distortion + Noise	-1 dBFS	-	-70	-	-	-70	-	dB
	-20 dBFS	-	-73	-	-	-71	-	dB
	-60 dBFS	-	-33	-	-	-31	-	dB
Full-scale Input Voltage		-	$0.91 \cdot VA$	-	-	$0.91 \cdot VA$	-	Vpp
Full-scale Output Voltage		-	$0.84 \cdot VA$	-	-	$0.84 \cdot VA$	-	Vpp
Output Power		-	32	-	-	17	-	mW
Passband Ripple		-	0/-0.3	-	-	0/-0.3	-	dB

## PWM OUTPUT CHARACTERISTICS

Test conditions (unless otherwise specified): Input test signal is a full scale 997 Hz signal; MCLK = 12.2880 MHz; Measurement Bandwidth is 20 Hz to 20 kHz; Sample Frequency = 48 kHz; Test load  $R_L = 8 \Omega$  for stereo full-bridge,  $R_L = 4 \Omega$  for mono parallel full-bridge;  $V_D = V_L = V_A = V_{HP} = 1.8V$ ; PWM Modulation Index of 0.85; PWM Switch Rate = 384 kHz.

Parameters (Note 7)	Symbol	Conditions	Min	Typ	Max	Units
<b>VP = 5.0 V</b>						
<b>Power Output per Channel</b>	$P_O$					
Stereo Full-Bridge		THD+N < 10% THD+N < 1%	-	1.00	-	$W_{rms}$ $W_{rms}$
Mono Parallel Full-Bridge		THD+N < 10% THD+N < 1%	-	1.90	-	$W_{rms}$ $W_{rms}$
<b>Total Harmonic Distortion + Noise</b>	THD+N					
Stereo Full-Bridge		$P_O = 0$ dBFS = 0.8W	-	0.52	-	%
Mono Parallel Full-Bridge		$P_O = -3$ dBFS = 0.75 W $P_O = 0$ dBFS = 1.5 W	-	0.10	-	% %
<b>Dynamic Range</b>	DR					
Stereo Full-Bridge		$P_O = -60$ dBFS, A-Weighted $P_O = -60$ dBFS, Unweighted	-	91	-	dB dB
Mono Parallel Full-Bridge		$P_O = -60$ dBFS, A-Weighted $P_O = -60$ dBFS, Unweighted	-	91	-	dB dB
<b>VP = 3.7 V</b>						
<b>Power Output per Channel</b>	$P_O$					
Stereo Full-Bridge		THD+N < 10% THD+N < 1%	-	0.55	-	$W_{rms}$ $W_{rms}$
Mono Parallel Full-Bridge		THD+N < 10% THD+N < 1%	-	1.00	-	$W_{rms}$ $W_{rms}$
<b>Total Harmonic Distortion + Noise</b>	THD+N					
Stereo Full-Bridge		$P_O = 0$ dBFS = 0.43 W	-	0.54	-	%
Mono Parallel Full-Bridge		$P_O = -3$ dBFS = 0.41 W $P_O = 0$ dBFS = 0.81 W	-	0.09	-	% %
<b>Dynamic Range</b>	DR					
Stereo Full-Bridge		$P_O = -60$ dBFS, A-Weighted $P_O = -60$ dBFS, Unweighted	-	91	-	dB dB
Mono Parallel Full-Bridge		$P_O = -60$ dBFS, A-Weighted $P_O = -60$ dBFS, Unweighted	-	95	-	dB dB
<b>VP = 2.5 V</b>						
<b>Power Output per Channel</b>	$P_O$					
Stereo Full-Bridge		THD+N < 10% THD+N < 1%	-	0.23	-	$W_{rms}$ $W_{rms}$
Mono Parallel Full-Bridge		THD+N < 10% THD+N < 1%	-	0.44	-	$W_{rms}$ $W_{rms}$
<b>Total Harmonic Distortion + Noise</b>	THD+N					
Stereo Full-Bridge		$P_O = 0$ dBFS = 0.18 W	-	0.50	-	%
Mono Parallel Full-Bridge		$P_O = -3$ dBFS = 0.17 W $P_O = 0$ dBFS = 0.35 W	-	0.08	-	% %
<b>Dynamic Range</b>	DR					
Stereo Full-Bridge		$P_O = -60$ dBFS, A-Weighted $P_O = -60$ dBFS, Unweighted	-	91	-	dB dB
Mono Parallel Full-Bridge		$P_O = -60$ dBFS, A-Weighted $P_O = -60$ dBFS, Unweighted	-	94	-	dB dB
MOSFET On Resistance	$R_{DS(ON)}$	VP = 5.0V, $I_d = 0.5$ A	-	600	-	m $\Omega$
MOSFET On Resistance	$R_{DS(ON)}$	VP = 3.7V, $I_d = 0.5$ A	-	640	-	m $\Omega$

Parameters (Note 7)	Symbol	Conditions	Min	Typ	Max	Units
MOSFET On Resistance	$R_{DS(ON)}$	$V_P = 2.5V, I_d = 0.5 A$	-	760	-	m $\Omega$
Efficiency	$\eta$	$V_P = 5.0 V, P_O = 2 \times 0.8 W, R_L = 8 \Omega$	-	81	-	%
Output Operating Peak Current	$I_{PC}$		-	-	1.5	A
VP Input Current During Reset	$I_{VP}$	$\overline{RESET}$ , pin 32, is held low	-	0.8	5.0	$\mu A$

6. The PWM driver should be used in captive speaker systems only.
7. Optimal PWM performance is achieved when  $MCLK > 12$  MHz.

## HEADPHONE OUTPUT POWER CHARACTERISTICS

Test conditions (unless otherwise specified): Input test signal is a full-scale 997 Hz sine wave; Sample Frequency = 48 kHz; Measurement Bandwidth is 20 Hz to 20 kHz; Test load  $R_L = 16 \Omega$ ,  $C_L = 10$  pF (see Figure 2); "Required Initialization Settings" on page 32 written on power up.

Parameters			VA = 2.5V			VA = 1.8V			Unit
			Min	Typ	Max	Min	Typ	Max	
<b>AOUTx Power Into <math>R_L = 16 \Omega</math></b>									
HP_GAIN[2:0]	Analog Gain (G)	VHP							
000	0.3959	1.8 V	-	14	-	-	7	-	mW <sub>rms</sub>
		2.5 V	-	14	-	-	7	-	mW <sub>rms</sub>
001	0.4571	1.8 V	-	19	-	-	10	-	mW <sub>rms</sub>
		2.5 V	-	19	-	-	10	-	mW <sub>rms</sub>
010	0.5111	1.8 V	-	23	-	-	12	-	mW <sub>rms</sub>
		2.5 V	-	23	-	-	12	-	mW <sub>rms</sub>
011 (default)	0.6047	1.8 V	(Note 8)			-	17	-	mW <sub>rms</sub>
		2.5 V	-	32	-	-	17	-	mW <sub>rms</sub>
100	0.7099	1.8 V	(Note 8)			-	23	-	mW <sub>rms</sub>
		2.5 V	-	44	-	-	23	-	mW <sub>rms</sub>
101	0.8399	1.8 V	(Note 4, 8) See Figures 18 and 19 on page 59			(Note 4) See Figure 18 on page 59			mW <sub>rms</sub>
		2.5 V				-	32	-	mW <sub>rms</sub>
110	1.0000	1.8 V	(Note 4, 8) See Figures 18 and 19 on page 59			(Note 4) See Figure 18 on page 59			mW <sub>rms</sub>
		2.5 V							(Note 4) See Figure 18 on page 59
111	1.1430	1.8 V	(Note 4, 8) See Figures 18 and 19 on page 59			(Note 4) See Figure 18 on page 59			
		2.5 V							(Note 4) See Figure 18 on page 59

8. VHP settings lower than VA reduces the headroom of the headphone amplifier. As a result, the DAC may not achieve the full THD+N performance at full-scale output voltage and power.

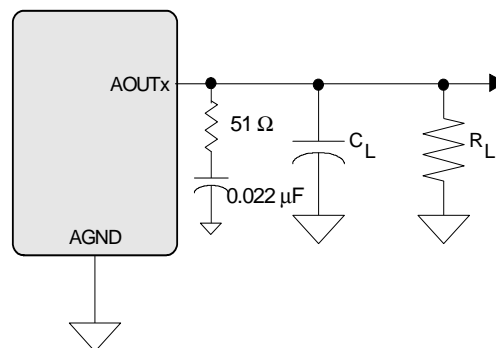

**Figure 2. Headphone Output Test Load**

## LINE OUTPUT VOLTAGE LEVEL CHARACTERISTICS

Test conditions (unless otherwise specified): Input test signal is a full-scale 997 Hz sine wave; measurement bandwidth is 20 Hz to 20 kHz; Sample Frequency = 48 kHz; Test load  $R_L = 10\text{ k}\Omega$ ,  $C_L = 10\text{ pF}$  (see [Figure 2](#)); “Required Initialization Settings” on [page 32](#) written on power up.

Parameters			VA = 2.5V			VA = 1.8V			Unit
			Min	Typ	Max	Min	Typ	Max	
<b>AOUTx Voltage Into <math>R_L = 10\text{ k}\Omega</math></b>									
HP_GAIN[2:0]	Analog Gain (G)	VHP							
000	0.3959	1.8 V	-	1.34	-	-	0.97	-	$V_{pp}$
		2.5 V	-	1.34	-	-	0.97	-	$V_{pp}$
001	0.4571	1.8 V	-	1.55	-	-	1.12	-	$V_{pp}$
		2.5 V	-	1.55	-	-	1.12	-	$V_{pp}$
010	0.5111	1.8 V	-	1.73	-	-	1.25	-	$V_{pp}$
		2.5 V	-	1.73	-	-	1.25	-	$V_{pp}$
011 (default)	0.6047	1.8 V	-	2.05	-	1.41	1.48	1.55	$V_{pp}$
		2.5 V	1.95	2.05	2.15	-	1.48	-	$V_{pp}$
100	0.7099	1.8 V	-	2.41	-	-	1.73	-	$V_{pp}$
		2.5 V	-	2.41	-	-	1.73	-	$V_{pp}$
101	0.8399	1.8 V	-	2.85	-	-	2.05	-	$V_{pp}$
		2.5 V	-	2.85	-	-	2.05	-	$V_{pp}$
110	1.0000	1.8 V	-	3.39	-	-	2.44	-	$V_{pp}$
		2.5 V	-	3.39	-	-	2.44	-	$V_{pp}$
111	1.1430	1.8 V	(See <a href="#">(Note 8)</a> )			-	2.79	-	$V_{pp}$
		2.5 V	-	3.88	-	-	2.79	-	$V_{pp}$

## COMBINED DAC INTERPOLATION & ON-CHIP ANALOG FILTER RESPONSE

Parameters <a href="#">(Note 9)</a>		Min	Typ	Max	Unit
Frequency Response 10 Hz to 20 kHz		-0.01	-	+0.08	dB
Passband	to -0.05 dB corner	0	-	0.4780	Fs
	to -3 dB corner	0	-	0.4996	Fs
StopBand		0.5465	-	-	Fs
StopBand Attenuation <a href="#">(Note 10)</a>		50	-	-	dB
Group Delay		-	9/Fs	-	s
De-emphasis Error	Fs = 32 kHz	-	-	+1.5/+0	dB
	Fs = 44.1 kHz	-	-	+0.05/-0.25	dB
	Fs = 48 kHz	-	-	-0.2/-0.4	dB

9. Response is clock dependent and will scale with Fs. Note that the response plots ([Figures 22 and 25 on page 63](#)) have been normalized to Fs and can be de-normalized by multiplying the X-axis scale by Fs.
10. Measurement Bandwidth is from Stopband to 3 Fs.

## SWITCHING SPECIFICATIONS - SERIAL PORT

Inputs: Logic 0 = DGND; Logic 1 = VL.

Parameters	Symbol	Min	Max	Units	
RESET pin Low Pulse Width (Note 11)		1	-	ms	
MCLK Frequency (Note 12)		(See "Serial Port Clocking" on page 29)		MHz	
MCLK Duty Cycle		45	55	%	
<b>Slave Mode</b>					
Sample Rate (LRCK)	$F_s$	(See "Serial Port Clocking" on page 29)		kHz	
LRCK Duty Cycle		45	55	%	
SCLK Frequency	$1/t_p$	-	$64 \cdot F_s$	Hz	
SCLK Duty Cycle		45	55	%	
LRCK Setup Time Before SCLK Rising Edge	$t_{s(LK-SK)}$	40	-	ns	
SDIN Setup Time Before SCLK Rising Edge	$t_{s(SD-SK)}$	20	-	ns	
SDIN Hold Time After SCLK Rising Edge	$t_h$	20	-	ns	
<b>Master Mode</b>					
Sample Rate (LRCK)	$F_s$	(See "Serial Port Clocking" on page 29)		Hz	
LRCK Duty Cycle		45	55	%	
SCLK Frequency	SCLK=MCLK mode MCLK=12.0000 MHz all other modes	$1/t_p$ $1/t_p$ $1/t_p$	- - -	12.0000 $68 \cdot F_s$ $64 \cdot F_s$	MHz Hz Hz
SCLK Duty Cycle		45	55	%	
SDIN Setup Time Before SCLK Rising Edge	$t_{s(SD-SK)}$	20	-	ns	
SDIN Hold Time After SCLK Rising Edge	$t_h$	20	-	ns	

11. After powering up the CS43L22, RESET should be held low after the power supplies and clocks are settled.

12. See "Example System Clock Frequencies" on page 61 for typical MCLK frequencies.

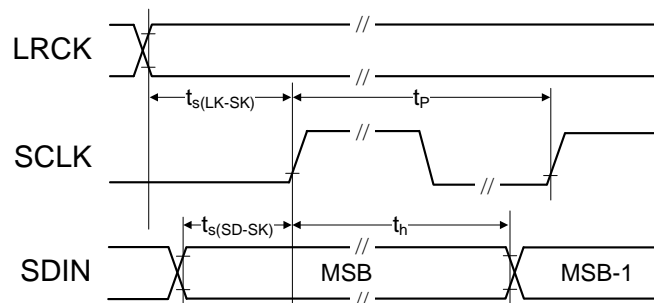

**Figure 3. Serial Audio Interface Timing**

## SWITCHING SPECIFICATIONS - I<sup>2</sup>C CONTROL PORT

Inputs: Logic 0 = DGND; Logic 1 = V; SDA C<sub>L</sub> = 30 pF.

Parameters	Symbol	Min	Max	Unit
SCL Clock Frequency	f <sub>scl</sub>	-	100	kHz
RESET Rising Edge to Start	t <sub>irs</sub>	550	-	ns
Bus Free Time Between Transmissions	t <sub>buf</sub>	4.7	-	μs
Start Condition Hold Time (prior to first clock pulse)	t <sub>hdst</sub>	4.0	-	μs
Clock Low time	t <sub>low</sub>	4.7	-	μs
Clock High Time	t <sub>high</sub>	4.0	-	μs
Setup Time for Repeated Start Condition	t <sub>sust</sub>	4.7	-	μs
SDA Hold Time from SCL Falling (Note 13)	t <sub>hdd</sub>	0	-	μs
SDA Setup time to SCL Rising	t <sub>sud</sub>	250	-	ns
Rise Time of SCL and SDA	t <sub>rc</sub>	-	1	μs
Fall Time SCL and SDA	t <sub>fc</sub>	-	300	ns
Setup Time for Stop Condition	t <sub>susp</sub>	4.7	-	μs
Acknowledge Delay from SCL Falling	t <sub>ack</sub>	300	1000	ns

13. Data must be held for sufficient time to bridge the transition time, t<sub>fc</sub>, of SCL.

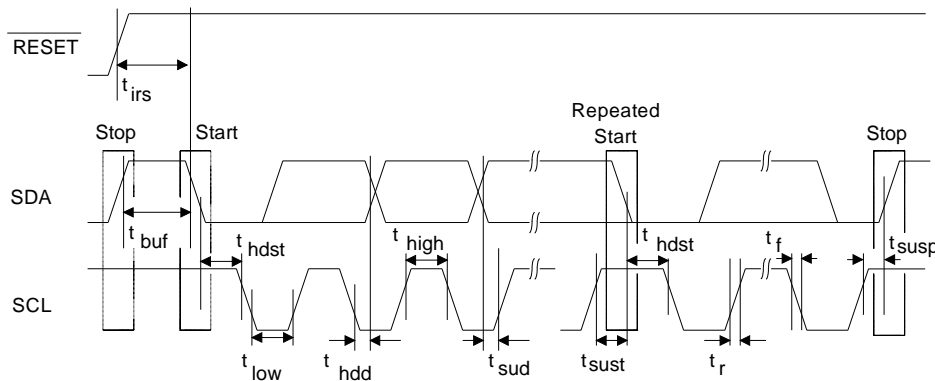

**Figure 4. Control Port Timing - I<sup>2</sup>C**

## DC ELECTRICAL CHARACTERISTICS

AGND = 0 V; all voltages with respect to ground.

Parameters	Min	Typ	Max	Units		
<b>VQ Characteristics</b>						
Nominal Voltage	-	0.5•VA	-	V		
Output Impedance	-	23	-	kΩ		
DC Current Source/Sink	-	-	1	μA		
<b>Power Supply Rejection Ratio Characteristics</b>						
PSRR @ 1 kHz (Note 14)		DAC (HP & Line Amps)	-	60	-	dB
PSRR @ 60 Hz (Note 14)		DAC (HP & Line Amps)	-	60	-	dB
PSRR @ 217 Hz		Full-Bridge PWM Outputs	-	56	-	dB

14. Valid with the recommended capacitor values on FILT+ and VQ. Increasing the capacitance will also increase the PSRR.

## DIGITAL INTERFACE SPECIFICATIONS & CHARACTERISTICS

Parameters (Note 15)	Symbol	Min	Max	Units	
Input Leakage Current	$I_{in}$	-	±10	μA	
Input Capacitance		-	10	pF	
<b>1.8 V - 3.3 V Logic</b>					
High-Level Output Voltage ( $I_{OH} = -100 \mu A$ )	$V_{OH}$	$V_L - 0.2$	-	V	
Low-Level Output Voltage ( $I_{OL} = 100 \mu A$ )	$V_{OL}$	-	0.2	V	
High-Level Input Voltage	$V_{IH}$	$V_L = 1.65 V$	0.85• $V_L$	-	V
		$V_L = 1.8 V$	0.77• $V_L$	-	V
		$V_L = 2.0 V$	0.68• $V_L$	-	V
		$V_L > 2.0 V$	0.65• $V_L$	-	V
Low-Level Input Voltage	$V_{IL}$	-	0.30• $V_L$	V	

15. See "I/O Pin Characteristics" on page 8 for serial and control port power rails.

**POWER CONSUMPTION** See (Note 16)

	Operation	Register Settings					V	Typical Current (mA)					Total Power (mW <sub>rms</sub> )
		02h	04h					i <sub>VHP</sub>	i <sub>VA</sub>	i <sub>VD</sub>	i <sub>VL</sub> VL=3.3V (Note 19)	i <sub>VP</sub> VP=3.7V	
		PDN[7:0]	PDN_HP[B]1:0]	PDN_HP[A]1:0]	PDN_SPK[B]1:0]	PDN_SPK[A]1:0]							
1	Off (Note 17)	x	x	x	x	x	1.8 2.5	0.00 0.00	0.00 0.00	0.00 0.00	0.00 0.00	0.00 0.00	<b>0.00</b> <b>0.00</b>
2	Standby (Note 18)	0x9F	x	x	x	x	1.8 2.5	0.00 0.00	0.00 0.00	0.01 0.02	0.00 0.00	0.00 0.00	<b>0.02</b> <b>0.05</b>
3	Stereo Passthrough to Headphone	0x9E	10	10	11	11	1.8 2.5	2.79 3.18	1.91 2.14	1.06 1.81	0.01 0.00	0.00 0.00	<b>10.39</b> <b>17.85</b>
4	Mono Playback to Headphone	0x9E	10	11	11	11	1.8 2.5	1.59 2.07	1.99 2.62	2.72 4.27	0.01 0.00	0.00 0.00	<b>11.36</b> <b>22.43</b>
5	Stereo Playback to Headphone	0x9E	10	10	11	11	1.8 2.5	2.77 3.27	2.00 2.63	2.91 4.28	0.01 0.00	0.00 0.00	<b>13.84</b> <b>25.48</b>
6	Mono Playback to Speaker	0x9E	11	11	10	10	1.8 2.5	0.00 0.00	0.20 0.22	4.42 6.77	0.01 1.00	1.00 1.00	<b>12.05</b> <b>21.21</b>
7	Stereo Playback to Speaker	0x9E	11	11	10	10	1.8 2.5	0.00 0.00	0.20 0.22	4.38 6.80	0.01 1.00	1.00 1.00	<b>11.98</b> <b>21.28</b>

16. Unless otherwise noted, test conditions are as follows: All zeros input, Slave Mode, sample rate = 48 kHz; No load. Digital (VD) and logic (VL) supply current will vary depending on speed mode and master/slave operation. "Required Initialization Settings" on page 32 written on power up.

17.  $\overline{\text{RESET}}$  pin 25 held LO, all clocks and data lines are held LO.

18.  $\overline{\text{RESET}}$  pin 25 held HI, all clocks and data lines are held HI.

19. VL current will slightly increase in Master Mode.

---

## 4. APPLICATIONS

### 4.1 Overview

#### 4.1.1 Basic Architecture

The CS43L22 is a highly integrated, low power, 24-bit audio DAC comprised of a Digital Signal Processing Engine, headphone amplifiers, a digital PWM modulator and two full-bridge power back-ends. Other features include battery level monitoring and compensation and temperature monitoring. The DAC is designed using multi-bit delta-sigma techniques and operates at an oversampling ratio of 128Fs, where Fs is equal to the system sample rate.

The PWM modulator operates at a fixed frequency of 384 kHz. The power MOSFETs are configured for either stereo full-bridge or mono parallel full bridge output. The DAC operates in one of four sample rate speed modes: Quarter, Half, Single and Double. It accepts and is capable of generating serial port clocks (SCLK, LRCK) derived from an input Master Clock (MCLK).

#### 4.1.2 Line Inputs

4 pairs of stereo analog inputs are provided for applications that require analog passthrough directly to the HP/Line amplifiers. This analog input portion allows selection from and configuration of multiple combinations of these stereo sources.

#### 4.1.3 Line & Headphone Outputs

The analog output portion of the CS43L22 includes a headphone amplifier capable of driving headphone and line-level loads. An on-chip charge pump creates a negative headphone supply allowing a full-scale output swing centered around ground. This eliminates the need for large DC-Blocking capacitors and allows the amplifier to deliver more power to headphone loads at lower supply voltages.

#### 4.1.4 Speaker Driver Outputs

The Class D power amplifiers drive 8  $\Omega$  (stereo) and 4  $\Omega$  (mono) speakers directly, without the need for an external filter. The power MOSFETS are powered directly from a battery eliminating the efficiency loss associated with an external regulator. Battery level monitoring and compensation maintains a steady output as battery levels fall. A temperature monitor continually measures the die temperature and registers when predefined thresholds are exceeded. **NOTE:** The CS43L22 should only be used in captive speaker systems where the outputs are permanently tied to the speaker terminals.

#### 4.1.5 Fixed Function DSP Engine

The fixed-function digital signal processing engine processes the PCM serial input data. Independent volume control, left/right channel swaps, mono mixes, tone control and limiting functions also comprise the DSP engine.

#### 4.1.6 Beep Generator

The beep generator delivers tones at select frequencies across approximately two octave major scales. With independent volume control, beeps may be configured to occur continuously, periodically, or at single time intervals.

#### 4.1.7 Power Management

Two control registers provide independent power-down control of the DAC, Headphone and Speaker output blocks in the CS43L22 allowing operation in select applications with minimal power consumption.

## 4.2 DSP Engine

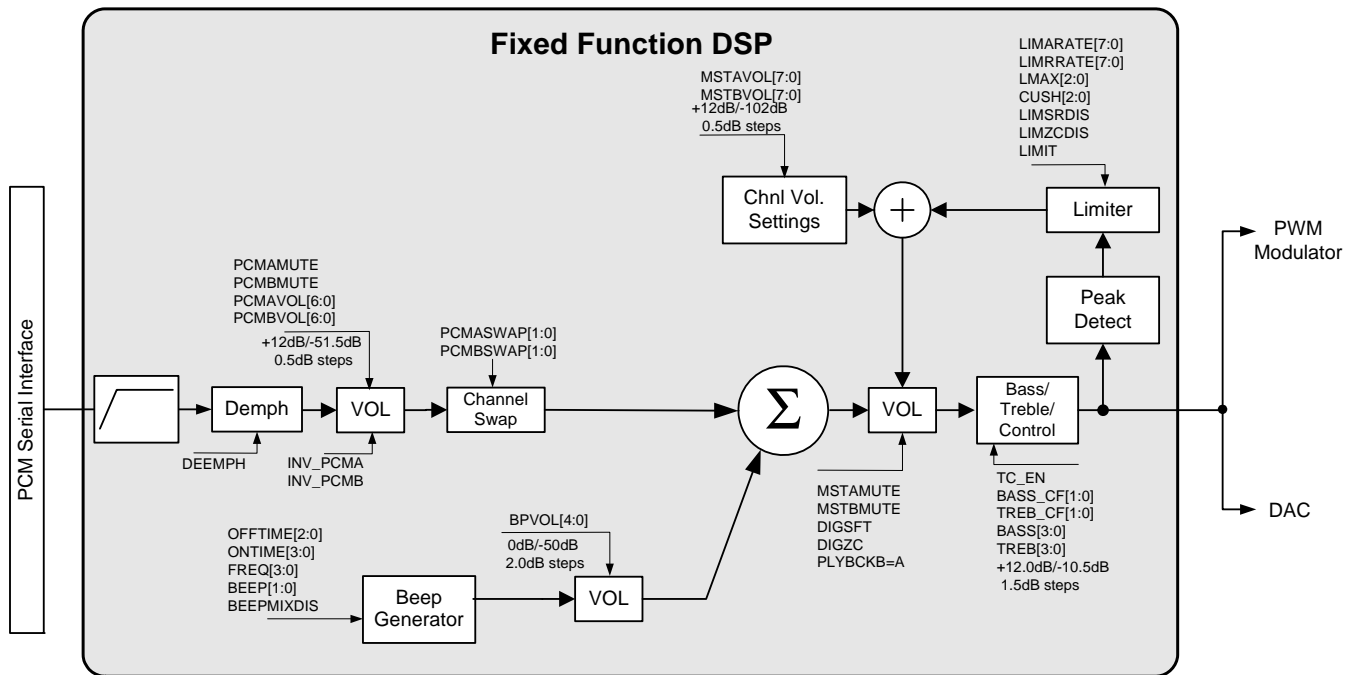

**Figure 5. DSP Engine Signal Flow**

Referenced Control	Register Location
<b>DSP</b>	
DEEMPH .....	"HP/Speaker De-Emphasis" on page 44
PCMAxMUTE .....	"PCM Channel x Mute" on page 47
PCMAxVOL[6:0] .....	"PCM Channel x Volume" on page 47
INV_PCMx .....	"Invert PCM Signal Polarity" on page 43
PCMAxSWAP[1:0] .....	"PCM Channel Swap" on page 52
MSTxVOL[7:0] .....	"Master Volume Control" on page 51
MSTxMUTE .....	"Master Playback Mute" on page 43
DIGSFT .....	"Digital Soft Ramp" on page 44
DIGZC .....	"Digital Zero Cross" on page 45
PLYBCKB=A .....	"Playback Volume Setting B=A" on page 43
TC_EN .....	"Tone Control Enable" on page 50
BASS_CF[1:0] .....	"Bass Corner Frequency" on page 50
TREB_CF[1:0] .....	"Treble Corner Frequency" on page 50
BASS[3:0] .....	"Bass Gain" on page 51
TREB[3:0] .....	"Treble Gain" on page 50
LIMIT .....	"Peak Detect and Limiter" on page 54
LIMSRDIS .....	"Limiter Soft Ramp Disable" on page 53
LIMZCDIS .....	"Limiter Zero Cross Disable" on page 54
LMAX[2:0] .....	"Limiter Maximum Threshold" on page 53
CUSH[2:0] .....	"Limiter Cushion Threshold" on page 53
LIMARATE[7:0] .....	"Limiter Attack Rate" on page 55
LIMRRATE[7:0] .....	"Limiter Release Rate" on page 54

### 4.2.1 Beep Generator

The Beep Generator generates audio frequencies across approximately two octave major scales. It offers three modes of operation: Continuous, multiple and single (one-shot) beeps. Sixteen on and eight off times are available.

**Note:** The Beep is generated before the limiter and may affect desired limiting performance. If the limiter function is used, it may be required to set the beep volume sufficiently below the threshold to prevent the peak detect from triggering. Since the master volume control, MSTxVOL[7:0], will affect the beep volume, DAC volume may alternatively be controlled using the PCMxVOL[6:0] bits.

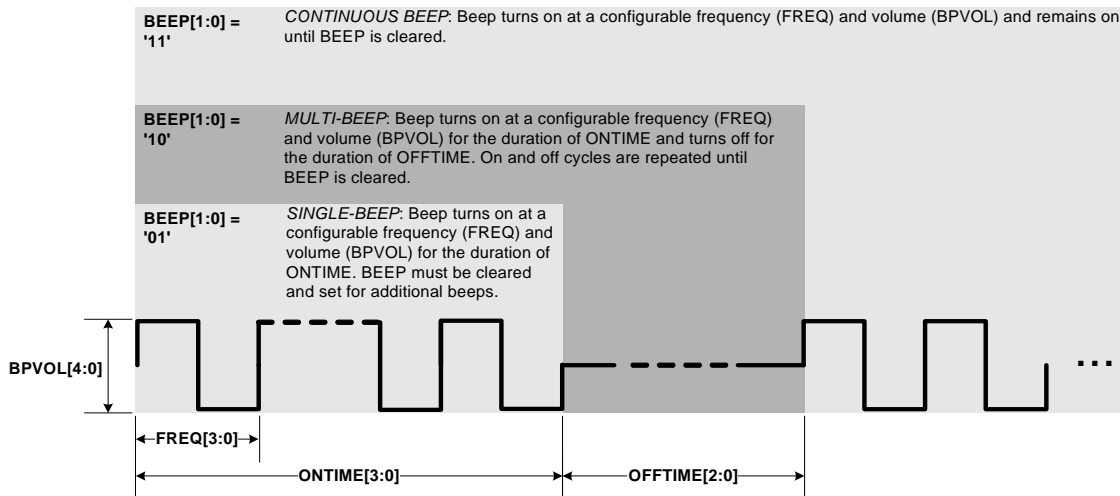

**Figure 6. Beep Configuration Options**

Referenced Control	Register Location
MSTxVOL[7:0].....	"Master Volume Control: MSTA (Address 20h) & MSTB (Address 21h)" on page 51
PCMxVOL[6:0].....	"PCMx Volume: PCMA (Address 1Ah) & PCMB (Address 1Bh)" on page 47
OFFTIME[2:0].....	"Beep Off Time" on page 48
ONTIME[3:0].....	"Beep On Time" on page 48
FREQ[3:0].....	"Beep Frequency" on page 47
BEEP[1:0].....	"Beep Configuration" on page 49
BEEP MIXDIS.....	"Beep Mix Disable" on page 49
BPVOL[4:0].....	"Beep Volume" on page 49

### 4.2.2 Limiter

When enabled, the limiter monitors the digital input signal before the DAC and PWM modulators, detects when levels exceed the maximum threshold settings and lowers the master volume at a programmable attack rate below the maximum threshold. When the input signal level falls below the maximum threshold, the AOUT volume returns to its original level set in the Master Volume Control register at a programmable release rate. Attack and release rates are affected by the DAC soft ramp/zero cross settings and sample rate, Fs. Limiter soft ramp and zero cross dependency may be independently enabled/disabled.

**Notes:**

1. *Recommended settings:* Best limiting performance may be realized with the fastest attack and slowest release setting with soft ramp enabled in the control registers. The MIN bits allow the user to set a threshold slightly below the maximum threshold for hysteresis control - this cushions the sound as the limiter attacks and releases.
2. The Limiter maintains the output signal between the CUSH and MAX thresholds. As the digital input signal level changes, the level-controlled output may not always be the same but will always fall within

the thresholds.

Referenced Control	Register Location
Limiter Controls .....	"Limiter Control 2, Release Rate (Address 28h)" on page 54, "Limiter Attack Rate (Address 29h)" on page 55
Master Volume Control.....	"Master Volume Control: MSTA (Address 20h) & MSTB (Address 21h)" on page 51

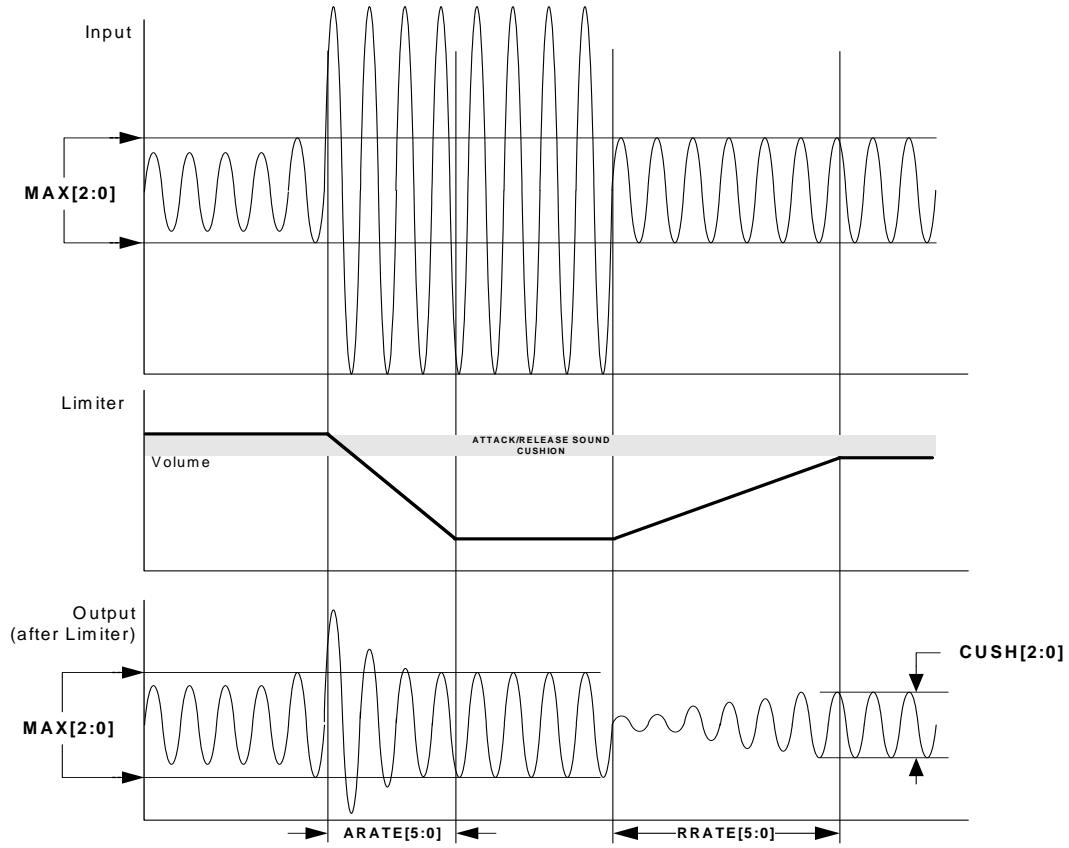
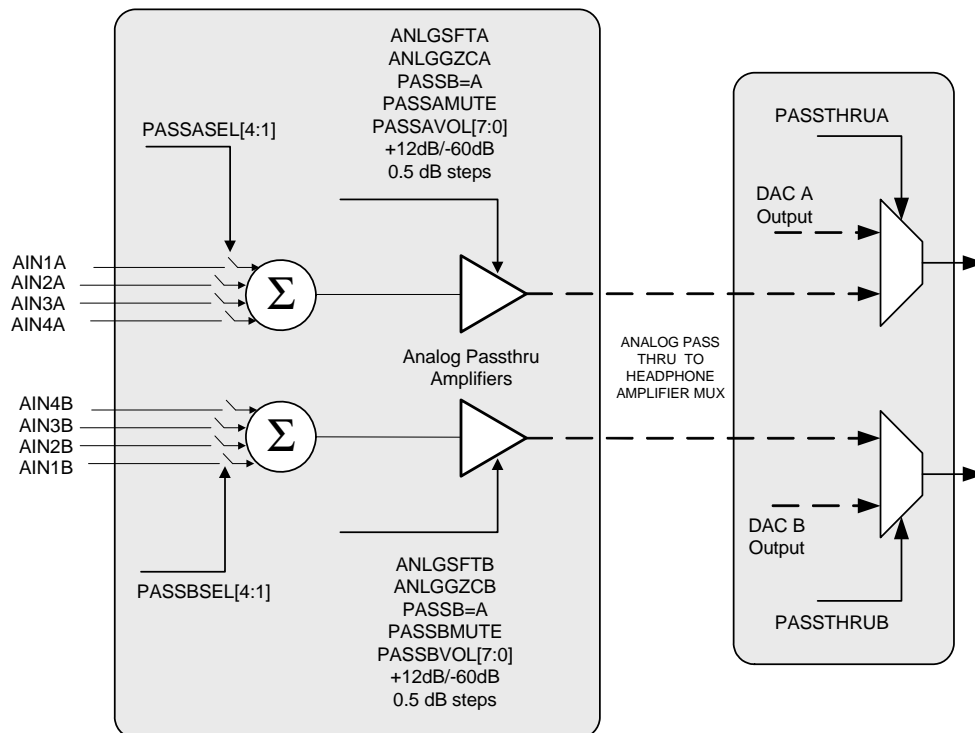

**Figure 7. Peak Detect & Limiter**

### 4.3 Analog Passthrough

The CS43L22 accommodates analog routing of the analog input signal directly to the headphone amplifiers by using the PASSTHRUx mux. This feature is useful in applications that utilize an FM tuner where audio recovered over-the-air must be transmitted to the headphone amplifier directly. This analog passthrough path reduces power consumption and is immune to modulator switching noise that could interfere with some tuners.

Four analog input channels can be chosen or summed by using the PASSxSEL bits as shown in Figure 8 to provide input to the CS43L22 when in analog passthrough mode. A pair of passthrough amplifiers can be used to mute and apply gain to the input signals.



**Figure 8. Analog Passthrough Signal Flow**

Referenced Control	Register Location
<b>Analog Front End</b>	
PASSB=A .....	"Passthrough Channel B=A Gang Control" on page 42
ANLGSFTx .....	"Ch. x Analog Soft Ramp" on page 42
ANLGZCx .....	"Ch. x Analog Zero Cross" on page 42
PASSxSEL4,3,2,1 .....	"Passthrough Input Channel Mapping" on page 42
PASSxMUTE .....	"Passthrough Mute" on page 44
PASSxVOL[7:0] .....	"Passthrough x Volume" on page 46
PASSTHRUx.....	"Passthrough Analog" on page 44

## 4.4 Analog Outputs

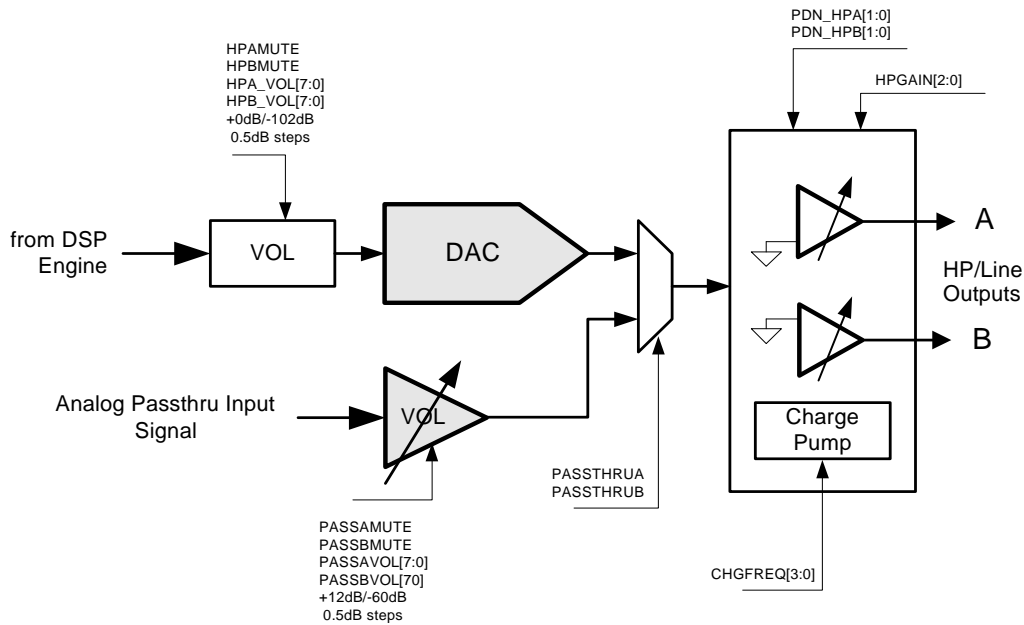
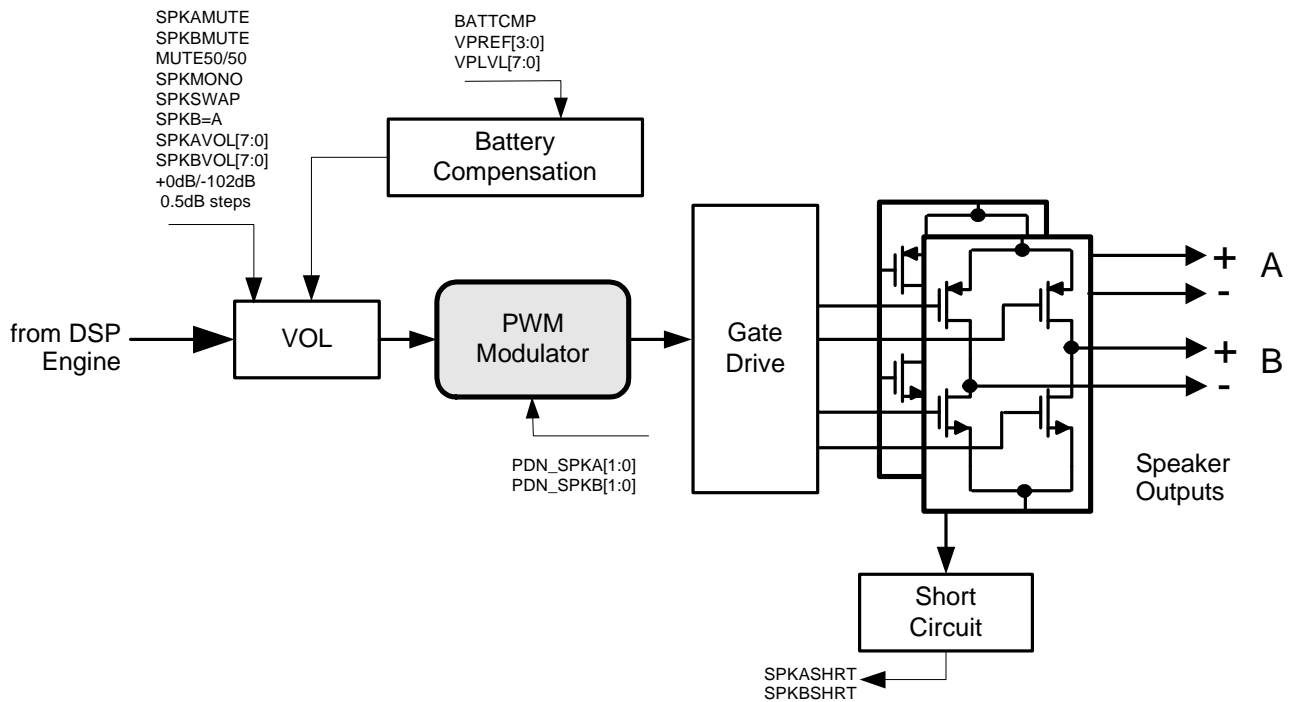

**Figure 9. Analog Outputs**

Referenced Control	Register Location
<b>Analog Output</b>	
HPxMUTE .....	"Headphone Mute" on page 45
HPxVOL[7:0] .....	"Headphone Volume Control" on page 51
PDN_HP[1:0] .....	"Headphone Power Control" on page 38
HPGAIN[2:0] .....	"Headphone Analog Gain" on page 43
PASSTHRUx .....	"Passthrough Analog" on page 44
PASSxMUTE .....	"Passthrough Mute" on page 44
PASSxVOL[7:0] .....	"Passthrough x Volume" on page 46
CHGFREQ .....	"Charge Pump Frequency" on page 58

## 4.5 PWM Outputs

**Note:** The PWM speaker amplifiers should not be used in the 384x MCLK modes (18.4320 and 16.9344 MHz).



**Figure 10. PWM Output Stage**

Referenced Control	Register Location
<b>PWM Control</b>	
SPKxMUTE .....	"Speaker Mute" on page 45
MUTE50/50 .....	"Speaker Mute 50/50 Control" on page 46
SPKxMONO .....	"Speaker MONO Control" on page 46
SPKxVOL[7:0] .....	"Speaker Volume Control" on page 52
SPKxSWAP .....	"Speaker Channel Swap" on page 45
SPKx=A .....	"Speaker Volume Setting B=A" on page 45
BATTxCMP .....	"Battery Compensation" on page 56
VPREF[3:0] .....	"VP Reference" on page 57
VPLVL[7:0] .....	"VP Voltage Level (Read Only)" on page 57
PDN_SPKx[1:0] .....	"Speaker Power Control" on page 38
SPKxSHRT .....	"Speaker Current Load Status (Read Only)" on page 57

### 4.5.1 Mono Speaker Output Configuration

The CS43L22 accommodates a stereo as well as a mono speaker output configuration. In mono mode the output drivers of each channel are connected in parallel to deliver maximum power to a 4 ohm speaker. Refer to the table below for pin mapping in mono configuration.

Pin	Speaker Output			
	SPKMONO=0		SPKMONO=1	
	SPKSWAP=0	SPKSWAP=1	SPKSWAP=0	SPKSWAP=1
4	SPKOUTA+	SPKOUTB+	SPKOUTA+	SPKOUTB+
6	SPKOUTA-	SPKOUTB-	SPKOUTA+	SPKOUTB+
7	SPKOUTB+	SPKOUTA+	SPKOUTA-	SPKOUTB-
9	SPKOUTB-	SPKOUTA-	SPKOUTA-	SPKOUTB-

Referenced Control	Register Location
SPKMONO.....	"Speaker MONO Control" on page 46
SPKSWAP.....	"Speaker Channel Swap" on page 45

### 4.5.2 VP Battery Compensation

The CS43L22 provides the option to maintain a desired power output level, independent of the VP supply. When enabled, this feature works by monitoring the voltage on the VP supply and *reducing the attenuation* on the speaker outputs when VP voltage levels fall.

**Note:** The internal ADC that monitors the VP supply operates from the VA supply. Calculations are based on typical VA levels of 1.8 V and 2.5 V using the VPREF bits.

#### 4.5.2.1 Maintaining a Desired Output Level

Using SPKxVOL, the speaker output level must first be attenuated by the decibel equivalent of the expected VP supply range (MAX relative to MIN). The CS43L22 then gradually *reduces* the attenuation as the VP supply drops from its maximum level, maintaining a nearly constant power output.

**Compensation Example 1** (VP Battery supply ranges from 4.5 V to 3.0 V)

1. Set speaker attenuation (SPKxVOL) to -3.5 dB. *The VP supply changes ~-3.5 dB.*
2. Set the reference VP supply (VPREF) to 4.5 V.
3. Enable battery compensation (BATTCMP).

*The CS43L22 automatically adjusts the output level as the battery discharges.*

**Compensation Example 2** (VP Battery supply ranges from 5.0 V to 1.6 V)

1. Set speaker attenuation (SPKxVOL) to -10 dB. *The VP supply changes ~-9.9 dB.*
2. Set the reference VP supply (VPREF) to 5.0 V.
3. Enable battery compensation (BATTCMP).

*The CS43L22 automatically adjusts the output level as the battery discharges. Refer to [Figure 11 on page 28](#). In this example, the VP supply changes over a wide range, illustrating the accuracy of the CS43L22's battery compensation.*

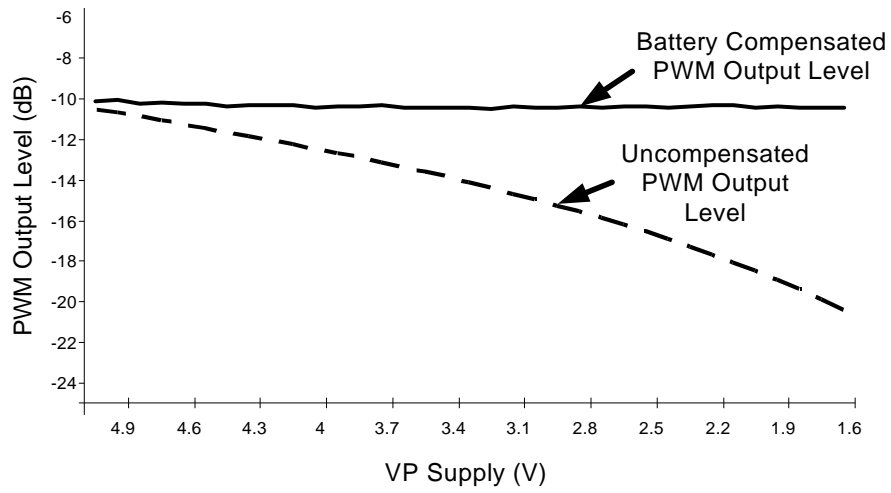

**Figure 11. Battery Compensation**

Referenced Control	Register Location
VPREF .....	<a href="#">"VP Reference" on page 57</a>
SPKxVOL .....	<a href="#">"Speaker Volume Control" on page 52</a>

## 4.6 Serial Port Clocking

The CS43L22 serial audio interface port operates either as a slave or master, determined by the  $M/\bar{S}$  bit. It accepts externally generated clocks in Slave Mode and will generate synchronous clocks derived from an input master clock (MCLK) in Master Mode. Refer to the tables below for the required setting in register 05h and 06h associated with a given MCLK and sample rate.

Referenced Control	Register Location
$M/\bar{S}$ .....	"Master/Slave Mode" on page 40
Register 05h.....	"Clocking Control (Address 05h)" on page 38
Register 06h.....	"Interface Control 1 (Address 06h)" on page 40

MCLK (MHz)	Sample Rate, Fs (kHz)	SPEED[1:0] (AUTO='0'b)	32kGROUP	VIDEOCLK	RATIO[1:0]	MCLKDIV2
12.2880	8.0000	11	1	0	00	0
	12.0000	11	0	0	00	0
	16.0000	10	1	0	00	0
	24.0000	10	0	0	00	0
	32.0000	01	1	0	00	0
	48.0000	01	0	0	00	0
11.2896	96.0000	00	0	0	00	0
	11.0250	11	0	0	00	0
	22.0500	10	0	0	00	0
	44.1000	01	0	0	00	0
18.4320 (Slave Mode ONLY)	88.2000	00	0	0	00	0
	8.0000	11	1	0	00	0
	12.0000	11	0	0	00	0
	16.0000	10	1	0	00	0
	24.0000	10	0	0	00	0
	32.0000	01	1	0	00	0
16.9344 (Slave Mode ONLY)	48.0000	01	0	0	00	0
	96.0000	00	0	0	00	0
	*8.0182...	11	0	0	10	0
	11.0250	11	0	0	00	0
	22.0500	10	0	0	00	0
12.0000	44.1000	01	0	0	00	0
	88.2000	00	0	0	00	0
	8.0000	11	1	0	01	0
	*11.0294...	11	0	0	11	0
	12.0000	11	0	0	01	0
	16.0000	10	1	0	01	0
	*22.0588...	10	0	0	11	0
	24.0000	10	0	0	01	0
	32.0000	01	1	0	01	0
	*44.1176...	01	0	0	11	0
24.0000	48.0000	01	0	0	01	0
	*88.2353...	00	0	0	11	0
	96.0000	00	0	0	01	0
	8.0000	11	1	0	01	1
	*11.0294...	11	0	0	11	1
	12.0000	11	0	0	01	1
	16.0000	10	1	0	01	1
	*22.0588...	10	0	0	11	1
	24.0000	10	0	0	01	1
	32.0000	01	1	0	01	1
*44.1176...	01	0	0	11	1	
48.0000	01	0	0	01	1	
*88.2353...	00	0	0	11	1	
96.0000	00	0	0	01	1	

MCLK (MHz)	Sample Rate, Fs (kHz)	SPEED[1:0] (AUTO='0'b)	32kGROUP	VIDEOCLK	RATIO[1:0]	MCLKDIV2
27.0000	8.0000	11	1	1	01	0
	12.0000	11	0	1	01	0
	24.0000	10	0	1	01	0
	32.0000	01	1	1	01	0
	*44.1176...	01	0	1	11	0
	48.0000	01	0	1	01	0
	*11.0294...	11	0	1	11	0
	*22.0588...	10	0	1	11	0
16.0000	10	1	1	01	0	

**Note:** \*The marked sample rate values are not exact representations of the actual frame clock frequency. They have been truncated to 4 decimal places. The exact value can be calculated by dividing the MCLK being used by the desired MCLK/LRCK ratio.

**Table 1. Serial Port Clocking**

## 4.7 Digital Interface Formats

The serial port operates in standard I<sup>2</sup>S, Left-Justified, Right-Justified, or DSP Mode digital interface formats with varying bit depths from 16 to 24. Data is clocked into the DAC on the rising edge of SCLK.

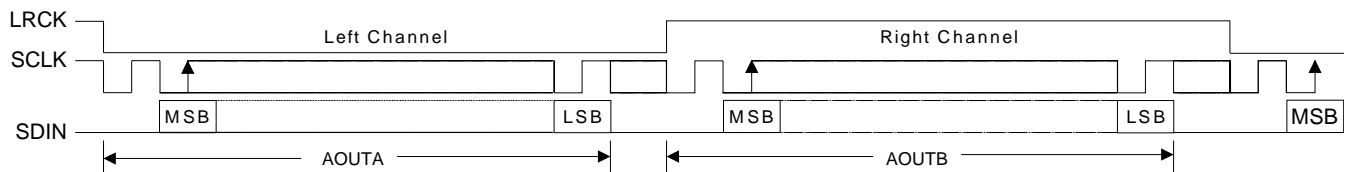

**Figure 12. I<sup>2</sup>S Format**

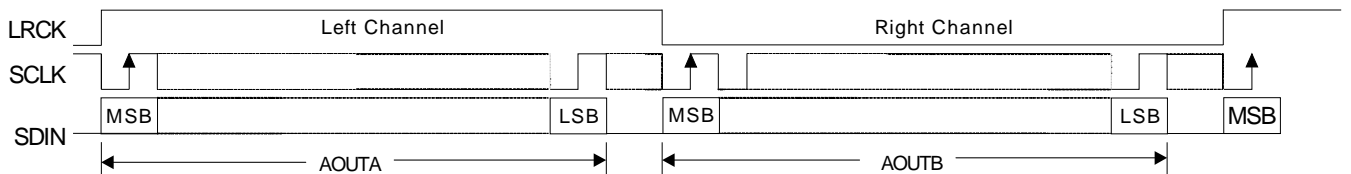

**Figure 13. Left-Justified Format**

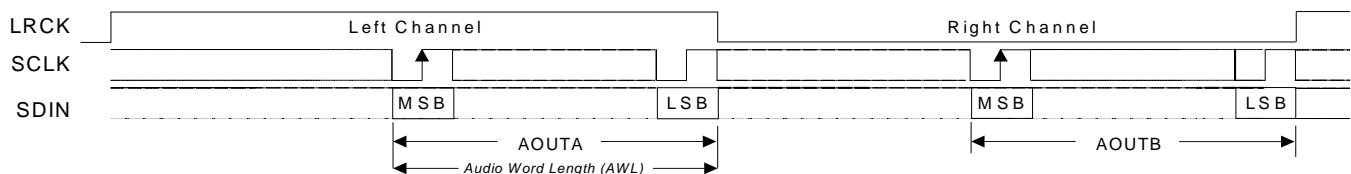

**Figure 14. Right-Justified Format**

### 4.7.1 DSP Mode

In DSP Mode, the LRCK acts as a frame sync for 2 data-packed words (left and right channel) input on SDIN. The MSB is input on the first SCLK rising edge after the frame sync rising edge. The right channel immediately follows the left channel.

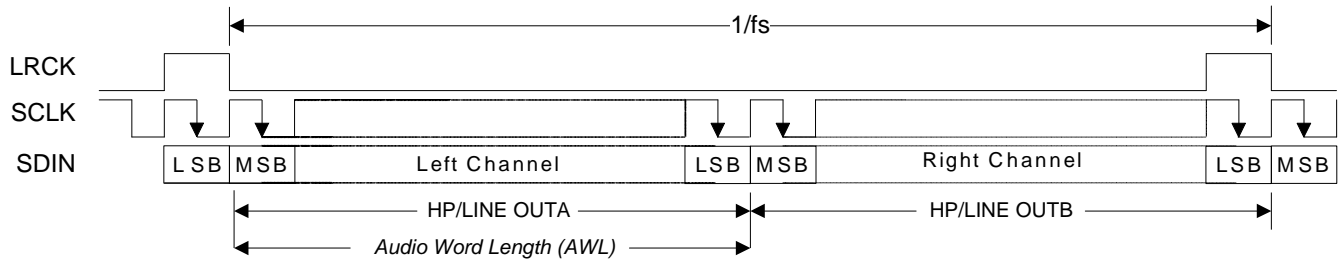

**Figure 15. DSP Mode Format)**

## 4.8 Initialization

The CS43L22 enters a Power-Down state upon initial power-up. The interpolation and decimation filters, delta-sigma and PWM modulators and control port registers are reset. The internal voltage reference, and switched-capacitor low-pass filters are powered down.

The device will remain in the Power-Down state until the  $\overline{\text{RESET}}$  pin is brought high. The control port is accessible once  $\overline{\text{RESET}}$  is high and the desired register settings can be loaded per the interface descriptions in the “[Register Description](#)” on page 37.

Once MCLK is valid, the quiescent voltage, VQ, and the internal voltage reference, FILT+, will begin powering up to normal operation. The charge pump slowly powers up and charges the capacitors. Power is then applied to the headphone amplifiers and switched-capacitor filters, and the analog/digital outputs enter a muted state. Once LRCK is valid, MCLK occurrences are counted over one LRCK period to determine the MCLK/LRCK frequency ratio and normal operation begins.

## 4.9 Recommended Power-Up Sequence

1. Hold  $\overline{\text{RESET}}$  low until the power supplies are stable.
2. Bring  $\overline{\text{RESET}}$  high.
3. The default state of the “Power Ctl. 1” register (0x02) is 0x01. Load the desired register settings while keeping the “Power Ctl 1” register set to 0x01.
4. Load the required initialization settings listed in [Section 4.11](#).
5. Apply MCLK at the appropriate frequency, as discussed in [Section 4.6](#). SCLK may be applied or set to master at any time; LRCK may only be applied or set to master while the PDN bit is set to 1.
6. Set the “Power Ctl 1” register (0x02) to 0x9E.
7. Bring  $\overline{\text{RESET}}$  low if the analog or digital supplies drop below the recommended operating condition to prevent power glitch related issues.

## 4.10 Recommended Power-Down Sequence

To minimize audible pops when turning off or placing the DAC in standby,

1. Mute the DAC’s and PWM outputs.
2. Disable soft ramp and zero cross volume transitions.
3. Set the “Power Ctl 1” register (0x02) to 0x9F.

4. Wait at least 100  $\mu$ s.  
The device will be fully powered down after this 100  $\mu$ s delay. Prior to the removal of the master clock (MCLK), this delay of at least 100  $\mu$ s must be implemented after step 3 to avoid premature disruption of the DAC's power down sequence.

A disruption in the device's power down sequence (i.e. removing the MCLK signal before this 100  $\mu$ s delay) has consequences on both the headphone and PWM speaker amplifiers: The charge pump may stop abruptly, causing the headphone amplifiers to drive the outputs up to the +VHP supply. Also, the last state of each '+' and '-' PWM output terminal before the premature removal of MCLK could randomly be held at either VP or AGND. When this event occurs, it is possible for each PWM terminal to output opposing potentials, creating a DC source into the speaker voice coil.

The disruption of the device's power down sequence may also cause clicks and pops on the output of the DAC's as the modulator holds the last output level before the MCLK signal was removed.

5. MCLK may be removed at this time.
6. To achieve the lowest operating quiescent current, bring  $\overline{\text{RESET}}$  low. All control port registers will be reset to their default state.

#### 4.11 Required Initialization Settings

Various sections in the device must be adjusted by implementing the initialization settings shown below after power-up sequence step 3. All performance and power consumption measurements were taken with the following settings:

1. Write 0x99 to register 0x00.
2. Write 0x80 to register 0x47.
3. Write '1'b to bit 7 in register 0x32.
4. Write '0'b to bit 7 in register 0x32.
5. Write 0x00 to register 0x00.

## 5. CONTROL PORT OPERATION

The control port is used to access the registers allowing the CS43L22 to be configured for the desired operational modes and formats. The operation of the control port may be completely asynchronous with respect to the audio sample rates. However, to avoid potential interference problems, the control port pins should remain static if no operation is required.

The control port operates using an I<sup>2</sup>C interface with the CS43L22 acting as a slave device.

### 5.1 I<sup>2</sup>C Control

SDA is a bidirectional data line. Data is clocked into and out of the device by the clock, SCL. The AD0 pin sets the LSB of the chip address; '0' when connected to DGND, '1' when connected to VL. This pin may be driven by a host controller or directly connected to VL or DGND. The AD0 pin state is sensed and the LSB of the chip address is set upon the release of the RESET signal (a low-to-high transition).

The signal timings for a read and write cycle are shown in Figure 16 and Figure 17. A Start condition is defined as a falling transition of SDA while the clock is high. A Stop condition is defined as a rising transition of SDA while the clock is high. All other transitions of SDA occur while the clock is low. The first byte sent to the CS43L22 after a Start condition consists of a 7-bit chip address field and a R/W bit (high for a read, low for a write).

The upper 6 bits of the address field are fixed at 100101. To communicate with the CS43L22, the chip address field, which is the first byte sent to the CS43L22, should match 100101 followed by the setting of the AD0 pin. The eighth bit of the address is the R/W bit. If the operation is a write, the next byte is the Memory Address Pointer (MAP), which selects the register to be read or written. If the operation is a read, the contents of the register pointed to by the MAP will be output. Setting the auto-increment bit in MAP allows successive reads or writes of consecutive registers. Each byte is separated by an acknowledge bit. The ACK bit is output from the CS43L22 after each input byte is read and is input to the CS43L22 from the microcontroller after each transmitted byte.

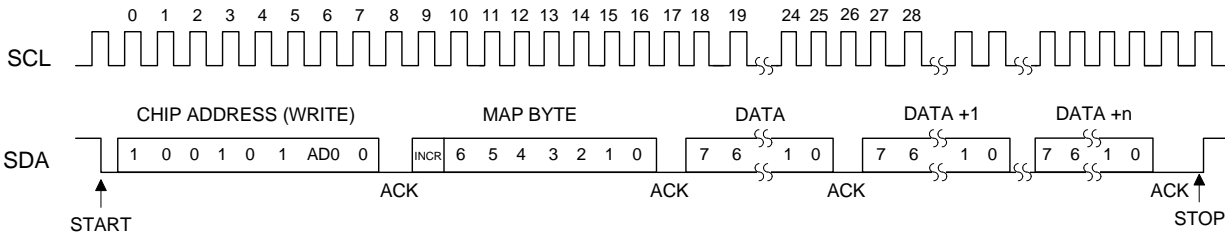

**Figure 16. Control Port Timing, I<sup>2</sup>C Write**

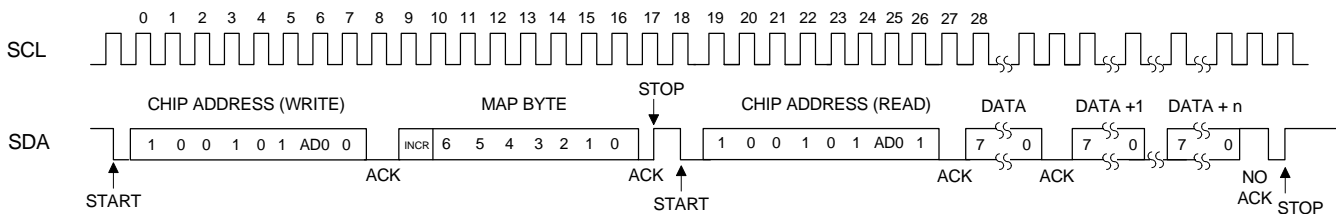

**Figure 17. Control Port Timing, I<sup>2</sup>C Read**

Since the read operation cannot set the MAP, an aborted write operation is used as a preamble. As shown in Figure 17, the write operation is aborted after the acknowledge for the MAP byte by sending a stop condition. The following pseudocode illustrates an aborted write operation followed by a read operation.

Send start condition.  
Send 10010100 (chip address & write operation).  
Receive acknowledge bit.  
Send MAP byte, auto-increment off.  
Receive acknowledge bit.  
Send stop condition, aborting write.  
Send start condition.  
Send 10010101 (chip address & read operation).  
Receive acknowledge bit.  
Receive byte, contents of selected register.  
Send acknowledge bit.  
Send stop condition.

Setting the auto-increment bit in the MAP allows successive reads or writes of consecutive registers. Each byte is separated by an acknowledge bit.

### **5.1.1 Memory Address Pointer (MAP)**

The MAP byte comes after the address byte and selects the register to be read or written. Refer to the pseudo code above for implementation details.

#### **5.1.1.1 Map Increment (INCR)**

The device has MAP auto-increment capability enabled by the INCR bit (the MSB) of the MAP. If INCR is set to 0, MAP will stay constant for successive I<sup>2</sup>C writes or reads. If INCR is set to 1, MAP will auto-increment after each byte is read or written, allowing block reads or writes of successive registers.

## 6. REGISTER QUICK REFERENCE

Default values are shown below the bit names. Unless otherwise specified, all “Reserved” bits must maintain their default value.

Adr.	Function	7	6	5	4	3	2	1	0
01h p 37	ID	CHIPID4 1	CHIPID3 1	CHIPID2 1	CHIPID1 0	CHIPID0 0	REVID2 x	REVID1 x	REVID0 x
02h p 37	Power Ctl 1	PDN7 0	PDN6 0	PDN5 0	PDN4 0	PDN3 0	PDN2 0	PDN1 0	PDN0 1
03h	Reserved	Reserved 0	Reserved 0	Reserved 0	Reserved 0	Reserved 0	Reserved 1	Reserved 1	Reserved 1
04h p 38	Power Ctl 2	PDN_HP B1 0	PDN_HP B0 0	PDN_HP A1 0	PDN_HP A0 0	PDN_SPKB1 0	PDN_SPKB0 1	PDN_SPKA1 0	PDN_SPKA0 1
05h p 38	Clocking Ctl	AUTO 1	SPEED1 0	SPEED0 1	32kGROUP 0	VIDEOCLK 0	RATIO1 0	RATIO0 0	MCLKDIV2 0
06h p 40	Interface Ctl 1	M/S 0	INV_SCLK 0	Reserved 0	DSP 0	DACDIF1 0	DACDIF0 0	AWL1 0	AWL0 0
07h p 41	Interface Ctl 2	Reserved 0	SCLK=MCLK 0	Reserved 0	Reserved 0	INV_SWCH 0	Reserved 0	Reserved 0	Reserved 0
08h p 42	Passthrough A Select	Reserved 1	Reserved 0	Reserved 0	Reserved 0	PASSASEL4 0	PASSASEL3 0	PASSASEL2 0	PASSASEL1 1
09h p 42	Passthrough B Select	Reserved 1	Reserved 0	Reserved 0	Reserved 0	PASSBSEL4 0	PASSBSEL3 0	PASSBSEL2 0	PASSBSEL1 1
0Ah p 42	Analog ZC and SR Settings	Reserved 1	Reserved 0	Reserved 1	Reserved 0	ANLGSFTB 0	ANLGZCB 1	ANLGSFTA 0	ANLGZCA 1
0Bh	Reserved	Reserved 0	Reserved 0	Reserved 0	Reserved 0	Reserved 0	Reserved 0	Reserved 0	Reserved 0
0Ch p 42	Passthrough Gang Control	PASSB=A 0	Reserved 0	Reserved 0	Reserved 0	Reserved 0	Reserved 0	Reserved 0	Reserved 0
0Dh p 43	Playback Ctl 1	HPGAIN2 0	HPGAIN1 1	HPGAIN0 1	PLYBCKB=A 0	INV_PCMB 0	INV_PCMA 0	MSTBMUTE 0	MSTAMUTE 0
0Eh p 44	Misc. Ctl	PASSTHRUB 0	PASSTHRUA 0	PASSBMUTE 0	PASSAMUTE 0	FREEZE 0	DEEMPH 0	DIGSFT 1	DIGZC 0
0Fh p 45	Playback Ctl 2	HPBMUTE 0	HPAMUTE 0	SPKBMUTE 0	SPKAMUTE 0	SPKB=A 0	SPKSWAP 0	SPKMONO 0	MUTE50/50 0
10h-13h	Reserved	Reserved 0	Reserved 0	Reserved 0	Reserved 0	Reserved 0	Reserved 0	Reserved 0	Reserved 0
14h p 46	Passthrough A Vol	PASSAVOL7 0	PASSAVOL6 0	PASSAVOL5 0	PASSAVOL4 0	PASSAVOL3 0	PASSAVOL2 0	PASSAVOL1 0	PASSAVOL0 0
15h p 46	Passthrough B Vol	PASSBVOL7 0	PASSBVOL6 0	PASSBVOL5 0	PASSBVOL4 0	PASSBVOL3 0	PASSBVOL2 0	PASSBVOL1 0	PASSBVOL0 0
16h-17h	Reserved	Reserved 0	Reserved 0	Reserved 0	Reserved 0	Reserved 0	Reserved 0	Reserved 0	Reserved 0
18h-19h	Reserved	Reserved 1	Reserved 0	Reserved 0	Reserved 0	Reserved 0	Reserved 0	Reserved 0	Reserved 0
1Ah p 47	PCMA Vol	PCMA MUTE 0	PCMAVOL6 0	PCMAVOL5 0	PCMAVOL4 0	PCMAVOL3 0	PCMAVOL2 0	PCMAVOL1 0	PCMAVOL0 0
1Bh p 47	PCMB Vol	PCMB MUTE 0	PCMBVOL6 0	PCMBVOL5 0	PCMBVOL4 0	PCMBVOL3 0	PCMBVOL2 0	PCMBVOL1 0	PCMBVOL0 0
1Ch p 47	BEEP Freq, On Time	FREQ3 0	FREQ2 0	FREQ1 0	FREQ0 0	ONTIME3 0	ONTIME2 0	ONTIME1 0	ONTIME0 0
1Dh p 48	BEEP Vol, Off Time	OFFTIME2 0	OFFTIME1 0	OFFTIME0 0	BPVOL4 0	BPVOL3 0	BPVOL2 0	BPVOL1 0	BPVOL0 0
1Eh p 49	BEEP, Tone Cfg.	BEEP1 0	BEEP0 0	BEEP MIXDIS 0	TREB_CF1 0	TREB_CF0 0	BASS_CF1 0	BASS_CF0 0	TC_EN 0
1Fh p 50	Tone Ctl	TREB3 1	TREB2 0	TREB1 0	TREB0 0	BASS3 1	BASS2 0	BASS1 0	BASS0 0

Adr.	Function	7	6	5	4	3	2	1	0
20h p 51	Master A Vol	MSTAVOL7 0	MSTAVOL6 0	MSTAVOL5 0	MSTAVOL4 0	MSTAVOL3 0	MSTAVOL2 0	MSTAVOL1 0	MSTAVOL0 0
21h p 51	Master B Vol	MSTBVOL7 0	MSTBVOL6 0	MSTBVOL5 0	MSTBVOL4 0	MSTBVOL3 0	MSTBVOL2 0	MSTBVOL1 0	MSTBVOL0 0
22h p 51	Headphone A Volume	HPAVOL7 0	HPAVOL6 0	HPAVOL5 0	HPAVOL4 0	HPAVOL3 0	HPAVOL2 0	HPAVOL1 0	HPAVOL0 0
23h p 51	Headphone B Volume	HPBVOL7 0	HPBVOL6 0	HPBVOL5 0	HPBVOL4 0	HPBVOL3 0	HPBVOL2 0	HPBVOL1 0	HPBVOL0 0
24h p 52	Speaker A Volume	SPKAVOL7 0	SPKAVOL6 0	SPKAVOL5 0	SPKAVOL4 0	SPKAVOL3 0	SPKAVOL2 0	SPKAVOL1 0	SPKAVOL0 0
25h p 52	Speaker B Volume	SPKBVOL7 0	SPKBVOL6 0	SPKBVOL5 0	SPKBVOL4 0	SPKBVOL3 0	SPKBVOL2 0	SPKBVOL1 0	SPKBVOL0 0
26h p 52	Channel Mixer & Swap	PCMASWP1 0	PCMASWP0 0	PCMBSWP1 0	PCMBSWP0 0	Reserved 0	Reserved 0	Reserved 0	Reserved 0
27h p 53	Limit Ctl 1, Thresholds	LMAX2 0	LMAX1 0	LMAX0 0	CUSH2 0	CUSH1 0	CUSH0 0	LIMSRDIS 0	LIMZCDIS 0
28h p 54	Limit Ctl 2, Release Rate	LIMIT 0	LIMIT_ALL 1	LIMRRATE5 1	LIMRRATE4 1	LIMRRATE3 1	LIMRRATE2 1	LIMRRATE1 1	LIMRRATE0 1
29h p 55	Limiter Attack Rate	Reserved 0	Reserved 0	LIMARATE5 0	LIMARATE4 0	LIMARATE3 0	LIMARATE2 0	LIMARATE1 0	LIMARATE0 0
2Ah	Reserved	Reserved 0	Reserved 0	Reserved 0	Reserved 0	Reserved 0	Reserved 0	Reserved 0	Reserved 0
2Bh	Reserved	Reserved 0	Reserved 0	Reserved 1	Reserved 1	Reserved 1	Reserved 1	Reserved 1	Reserved 1
2Ch-2Dh	Reserved	Reserved 0	Reserved 0	Reserved 0	Reserved 0	Reserved 0	Reserved 0	Reserved 0	Reserved 0
2Eh p 55	Overflow & Clock Status	Reserved 0	SPCLKERR 0	DSPBOVFL 0	DSPAOVFL 0	PCMAOVFL 0	PCMBOVFL 0	Reserved 0	Reserved 0
2Fh p 56	Battery Compensation	BATTCMP 0	VPMONITOR 0	Reserved 0	Reserved 0	VPREF3 0	VPREF2 0	VPREF1 0	VPREF0 0
30h p 57	VP Battery Level	VPLVL7 0	VPLVL6 0	VPLVL5 0	VPLVL4 0	VPLVL3 0	VPLVL2 0	VPLVL1 0	VPLVL0 0
31h p 57	Speaker Status	Reserved 0	Reserved 0	SPKASHRT 0	SPKBSHRT 0	SPKR/HP 0	Reserved 0	Reserved 0	Reserved 0
32h	Reserved	Reserved 0	Reserved 0	Reserved 1	Reserved 1	Reserved 1	Reserved 0	Reserved 1	Reserved 1
33h	Reserved	Reserved 0	Reserved 0	Reserved 0	Reserved 0	Reserved 0	Reserved 0	Reserved 0	Reserved 0
34h p 58	Charge Pump Frequency	CHGFREQ3 0	CHGFREQ2 1	CHGFREQ1 0	CHGFREQ0 1	Reserved 1	Reserved 1	Reserved 1	Reserved 1

## 7. REGISTER DESCRIPTION

All registers are read/write except for the chip I.D. and Revision Register and Interrupt Status Register which are read only. See the following bit definition tables for bit assignment information. The default state of each bit after a power-up sequence or reset is shown as shaded in the table. Unless otherwise specified, all “Reserved” bits must maintain their default value.

### 7.1 Chip I.D. and Revision Register (Address 01h) (Read Only)

7	6	5	4	3	2	1	0
CHIPID4	CHIPID3	CHIPID2	CHIPID1	CHIPID0	REVID2	REVID1	REVID0

#### 7.1.1 Chip I.D. (Read Only)

I.D. code for the CS43L22.

CHIPID[4:0]	Device
11100	CS43L22

#### 7.1.2 Chip Revision (Read Only)

CS43L22 revision level.

REVID[2:0]	Revision Level
000	A0
001	A1
010	B0
011	B1

### 7.2 Power Control 1 (Address 02h)

7	6	5	4	3	2	1	0
PDN7	PDN6	PDN5	PDN4	PDN3	PDN2	PDN1	PDN0

#### 7.2.1 Power Down

Configures the power state of the CS43L22.

PDN[7:0]	Status
0000 0001	Powered Down - same as setting 1001 1111
1001 1110	Powered Up
1001 1111	Powered Down - same as setting 0000 0001

**Note:**

1. All states of PDN[7:0] not shown in the table are reserved.

### 7.3 Power Control 2 (Address 04h)

7	6	5	4	3	2	1	0
PDN_HP B1	PDN_HP B0	PDN_HP A1	PDN_HP A0	PDN_SPK B1	PDN_SPK B0	PDN_SPK A1	PDN_SPK A0

#### 7.3.1 Headphone Power Control

Configures how the SPK/HP\_SW pin, 6, controls the power for the headphone amplifier.

PDN_HPx[1:0]	Headphone Status
00	Headphone channel is ON when the SPK/HP_SW pin, 6, is LO. Headphone channel is OFF when the SPK/HP_SW pin, 6, is HI.
01	Headphone channel is ON when the SPK/HP_SW pin, 6, is HI. Headphone channel is OFF when the SPK/HP_SW pin, 6, is LO.
10	Headphone channel is always ON.
11	Headphone channel is always OFF.

#### 7.3.2 Speaker Power Control

Configures how the SPK/HP\_SW pin, 6, controls the power for the speaker amplifier.

PDN_SPKx[1:0]	Speaker Status
00	Speaker channel is ON when the SPK/HP_SW pin, 6, is LO. Speaker channel is OFF when the SPK/HP_SW pin, 6, is HI.
01	Speaker channel is ON when the SPK/HP_SW pin, 6, is HI. Speaker channel is OFF when the SPK/HP_SW pin, 6, is LO.
10	Speaker channel is always ON.
11	Speaker channel is always OFF.

### 7.4 Clocking Control (Address 05h)

7	6	5	4	3	2	1	0
AUTO	SPEED1	SPEED0	32k_GROUP	VIDEOCLK	RATIO1	RATIO0	MCLKDIV2

#### 7.4.1 Auto-Detect

Configures the auto-detect circuitry for detecting the speed mode of the CS43L22 when operating as a slave.

AUTO	Auto-detection of Speed Mode
0	Disabled
1	Enabled
<b>Application:</b>	<a href="#">"Serial Port Clocking" on page 29</a>

#### Notes:

1. The SPEED[1:0] bits are ignored and speed is determined by the MCLK/LRCK ratio.
2. When AUTO is disabled and the CS43L22 operates in Master Mode, the MCLKDIV2 bit is ignored.
3. Certain sample and MCLK frequencies require setting the SPEED[1:0] bits, the 32k\_GROUP bit ("[32kHz Sample Rate Group](#)" on page 39) and/or the VIDEOCLK bit ("[27 MHz Video Clock](#)" on page 39) and RATIO[1:0] bits ("[Internal MCLK/LRCK Ratio](#)" on page 39). Low sample rates may also affect dynamic range performance in the typical audio band. Refer to the referenced application for more information.

### 7.4.2 Speed Mode

Configures the speed mode of the DAC in Slave Mode and sets the appropriate MCLK divide ratio for LRCK and SCLK in Master Mode.

SPEED[1:0]	Slave Mode	Master Mode	
	Serial Port Speed	MCLK/LRCK Ratio	SCLK/LRCK Ratio
00	Double-Speed Mode (DSM - 50 kHz - 100 kHz Fs)	512	64
01	Single-Speed Mode (SSM - 4 kHz - 50 kHz Fs)	256	64
10	Half-Speed Mode (HSM - 12.5kHz - 25 kHz Fs)	128	64
11	Quarter-Speed Mode (QSM - 4 kHz - 12.5 kHz Fs)	128	64
<b>Application:</b>	"Serial Port Clocking" on page 29		

#### Notes:

1. Slave/Master Mode is determined by the M/ $\bar{S}$  bit in "Master/Slave Mode" on page 40.
2. Certain sample and MCLK frequencies require setting the SPEED[1:0] bits, the 32k\_GROUP bit ("32kHz Sample Rate Group" on page 39) and/or the VIDEOCLK bit ("27 MHz Video Clock" on page 39) and RATIO[1:0] bits ("Internal MCLK/LRCK Ratio" on page 39). Low sample rates may also affect dynamic range performance in the typical audio band. Refer to the referenced application for more information.
3. These bits are ignored when the AUTO bit ("Auto-Detect" on page 38) is enabled.

### 7.4.3 32kHz Sample Rate Group

Specifies whether or not the input/output sample rate is 8 kHz, 16 kHz or 32 kHz.

32kGROUP	8 kHz, 16 kHz or 32 kHz sample rate?
0	No
1	Yes
<b>Application:</b>	"Serial Port Clocking" on page 29

### 7.4.4 27 MHz Video Clock

Specifies whether or not the external MCLK frequency is 27 MHz

VIDEOCLK	27 MHz MCLK?
0	No
1	Yes
<b>Application:</b>	"Serial Port Clocking" on page 29

### 7.4.5 Internal MCLK/LRCK Ratio

Configures the internal MCLK/LRCK ratio.

RATIO[1:0]	Internal MCLK Cycles per LRCK	SCLK/LRCK Ratio in Master Mode
00	128	64
01	125	62
10	132	66
11	136	68
<b>Application:</b>	"Serial Port Clocking" on page 29	

### 7.4.6 MCLK Divide By 2

Divides the input MCLK by 2 prior to all internal circuitry.

MCLKDIV2	MCLK signal into DAC
0	No divide
1	Divided by 2
<b>Application:</b>	<a href="#">“Serial Port Clocking” on page 29</a>

**Note:** In Slave Mode, this bit is ignored when the AUTO bit ([“Auto-Detect” on page 38](#)) is disabled.

## 7.5 Interface Control 1 (Address 06h)

7	6	5	4	3	2	1	0
M/S	INV_SCLK	Reserved	DSP	DACDIF1	DACDIF0	AWL1	AWL0

### 7.5.1 Master/Slave Mode

Configures the serial port I/O clocking.

M/S	Serial Port Clocks
0	Slave (input ONLY)
1	Master (output ONLY)

### 7.5.2 SCLK Polarity

Configures the polarity of the SCLK signal.

INV_SCLK	SCLK Polarity
0	Not Inverted
1	Inverted

### 7.5.3 DSP Mode

Configures a data-packed interface format for the DAC.

DSP	DSP Mode
0	Disabled
1	Enabled
<b>Application:</b>	<a href="#">“DSP Mode” on page 31</a>

**Notes:**

1. Select the audio word length using the AWL[1:0] bits ([“Audio Word Length” on page 41](#)).
2. The interface format for the DAC must be set to “Left-Justified” when DSP Mode is enabled.

### 7.5.4 DAC Interface Format

Configures the digital interface format for data on SDIN.

DACDIF[1:0]	DAC Interface Format
00	Left Justified, up to 24-bit data
01	IPS, up to 24-bit data
10	Right Justified
11	Reserved
<b>Application:</b>	<a href="#">“Digital Interface Formats” on page 30</a>

**Note:** Select the audio word length for Right Justified using the AWL[1:0] bits ([“Audio Word Length” on page 41](#)).

### 7.5.5 Audio Word Length

Configures the audio sample word length used for the data into SDIN.

AWL[1:0]	Audio Word Length	
	DSP Mode	Right Justified
00	32-bit data	24-bit data
01	24-bit data	20-bit data
10	20-bit data	18-bit data
11	16-bit data	16-bit data
Application:	<a href="#">"DSP Mode" on page 31</a>	

**Note:** When the internal MCLK/LRCK ratio is set to 125 in Master Mode, the 32-bit data width option for DSP Mode is not valid unless SCLK=MCLK.

## 7.6 Interface Control 2 (Address 07h)

7	6	5	4	3	2	1	0
Reserved	SCLK=MCLK	Reserved	Reserved	INV_SWCH	Reserved	Reserved	Reserved

### 7.6.1 SCLK equals MCLK

Configures the SCLK signal source for Master Mode.

SCLK=MCLK	Output SCLK
0	Re-timed signal, synchronously derived from MCLK
1	Non-retimed, MCLK signal

**Note:** This bit is only valid for MCLK = 12.0000 MHz.

### 7.6.2 Speaker/Headphone Switch Invert

Determines the control signal polarity of the SPK/HP\_SW pin.

INV_SWCH	SPK/HP_SW pin 6 Control
0	Not inverted
1	Inverted

## 7.7 Passthrough x Select: PassA (Address 08h), PassB (Address 09h)

7	6	5	4	3	2	1	0
Reserved	Reserved	Reserved	Reserved	PASSASEL4	PASSASEL3	PASSASEL2	PASSASEL1

### 7.7.1 Passthrough Input Channel Mapping

Selects one or sums/mixes the analog input signal into the passthrough Amplifier. Each bit of the PASSx\_SEL[4:1] word corresponds to individual channels (i.e. PASSx\_SEL1 selects AIN1x, PASSx\_SEL2 selects AIN2x, etc.).

PASSxSEL[4:1]	Selected Input to Passthrough Channel x
00000	No inputs selected
00001	AIN1x
00010	AIN2x
00100	AIN3x
01000	AIN4x
<b>Application:</b>	<a href="#">"Analog Passthrough" on page 24</a>

Note: Table does not show all possible combinations.

## 7.8 Analog ZC and SR Settings (Address 0Ah)

7	6	5	4	3	2	1	0
Reserved	Reserved	Reserved	Reserved	ANLGSFTB	ANLGZCB	ANLGSFTA	ANLGZCA

### 7.8.1 Ch. x Analog Soft Ramp

Configures an incremental volume ramp from the current level to the new level at the specified rate.

ANLGSFTx	Volume Changes	Affected Analog Volume Controls
0	Do not occur with a soft ramp	PASSxVOL[7:0] ( <a href="#">"Passthrough x Volume" on page 46</a> )
1	Occur with a soft ramp	
<b>Ramp Rate:</b>	1/2 dB every 16 LRCK cycles	

### 7.8.2 Ch. x Analog Zero Cross

Configures when the signal level changes occur for the analog volume controls.

ANLGZCx	Volume Changes	Affected Analog Volume Controls
0	Do not occur on a zero crossing	PASSxVOL[7:0] ( <a href="#">"Passthrough x Volume" on page 46</a> )
1	Occur on a zero crossing	

**Note:** If the signal does not encounter a zero crossing, the requested volume change will occur after a timeout period of 1024 sample periods (approximately 10.7 ms at 48 kHz sample rate).

## 7.9 Passthrough Gang Control (Address 0Ch)

7	6	5	4	3	2	1	0
PASSB=A	Reserved	Reserved	Reserved	Reserved	Reserved	Reserved	Reserved

### 7.9.1 Passthrough Channel B=A Gang Control

Configures independent or ganged control of the passthrough channel settings. Mute is not affected.

PASSB=A	Single Volume Control
0	Disabled
1	Enabled

## 7.10 Playback Control 1 (Address 0Dh)

7	6	5	4	3	2	1	0
HPGAIN2	HPGAIN1	HPGAIN0	PLYBCKB=A	INV_PCMB	INV_PCMA	MSTBMUTE	MSTAMUTE

### 7.10.1 Headphone Analog Gain

Selects the gain multiplier for the headphone/line outputs.

HPGAIN[2:0]	Headphone/Line Gain Setting (G)
000	0.3959
001	0.4571
010	0.5111
011	0.6047
100	0.7099
101	0.8399
110	1.000
111	1.1430

**Note:** Refer to “Headphone Output Power Characteristics” on page 14 and “Headphone Output Power Characteristics” on page 14.

### 7.10.2 Playback Volume Setting B=A

Configures independent or ganged volume control of all playback channels. Mute is not affected.

PLYBCKB=A	Single Volume Control for all Playback Channels
0	Disabled
1	Enabled

### 7.10.3 Invert PCM Signal Polarity

Configures the polarity of the digital input signal.

INV_PCMx	PCM Signal Polarity
0	Not Inverted
1	Inverted

### 7.10.4 Master Playback Mute

Configures a digital mute on the master volume control for channel x.

MSTxMUTE	Master Mute
0	Not Inverted
1	Inverted

**Note:** The muting function is affected by the DIGSFT (“Digital Soft Ramp” on page 44) and DIGZC (“Digital Zero Cross” on page 45) bits.

## 7.11 Miscellaneous Controls (Address 0Eh)

7	6	5	4	3	2	1	0
PASSTHRUB	PASSTHRUA	PASSBMUTE	PASSAMUTE	FREEZE	DEEMPH	DIGSFT	DIGZC

### 7.11.1 Passthrough Analog

Configures an analog passthrough from the analog inputs to the headphone/line outputs.

PASSTHRUx	Analog In Routed to HP/Line Output
0	Disabled
1	Enabled

### 7.11.2 Passthrough Mute

Configures an analog mute on the channel x analog in to analog out passthrough.

PASSxMUTE	Passthrough Mute
0	Disabled
1	Enabled

### 7.11.3 Freeze Registers

Configures a hold on all register settings.

FREEZE	Control Port Status
0	Register changes take effect immediately
1	Modifications may be made to all control port registers without the changes taking effect until after the FREEZE is disabled.

### 7.11.4 HP/Speaker De-Emphasis

Configures a 15 $\mu$ s/50 $\mu$ s digital de-emphasis filter response on the headphone/line and speaker outputs.

DEEMPHASIS	Control Port Status
0	Disabled
1	Enabled

### 7.11.5 Digital Soft Ramp

Configures an incremental volume ramp from the current level to the new level at the specified rate.

DIGSFT	Volume Changes	Affected Digital Volume Controls
0	Does not occur with a soft ramp	MSTxMUTE ("Master Playback Mute" on page 43), HPxMUTE, SPKxMUTE ("Playback Control 2 (Address 0Fh)" on page 45), PCMxMUTE, PCMxVOL[7:0] ("PCM Channel x Volume" on page 47), MSTxVOL[7:0] ("Master Volume Control" on page 51), HPxVOL[7:0] ("Headphone Volume Control" on page 51), SPKxVOL[7:0] ("Speaker Volume Control" on page 52),
1	Occurs with a soft ramp	
<b>Ramp Rate:</b>	1/8 dB every LRCK cycle	

### 7.11.6 Digital Zero Cross

Configures when the signal level changes occur for the digital volume controls.

DIGZC	Volume Changes	Affected Digital Volume Controls
0	Do not occur on a zero crossing	MSTxMUTE (“ <a href="#">Master Playback Mute</a> ” on page 43), HPxMUTE, SPKxMUTE (“ <a href="#">Playback Control 2 (Address 0Fh)</a> ” on page 45), PCMxMUTE, PCMxVOL[7:0] (“ <a href="#">PCM Channel x Volume</a> ” on page 47),
1	Occur on a zero crossing	MSTxVOL[7:0] (“ <a href="#">Master Volume Control</a> ” on page 51), HPxVOL[7:0] (“ <a href="#">Headphone Volume Control</a> ” on page 51), SPKxVOL[7:0] (“ <a href="#">Speaker Volume Control</a> ” on page 52),

**Notes:**

1. If the signal does not encounter a zero crossing, the requested volume change will occur after a timeout period between 1024 and 2048 sample periods (21.3 ms to 42.7 ms at 48 kHz sample rate).
2. The zero cross function is independently monitored and implemented for each channel.
3. The DIS\_LIMSFT bit (“[Limiter Soft Ramp Disable](#)” on page 53) is ignored when zero cross is enabled.

### 7.12 Playback Control 2 (Address 0Fh)

7	6	5	4	3	2	1	0
HPBMUTE	HPAMUTE	SPKBMUTE	SPKAMUTE	SPKB=A	SPKSWAP	SPKMONO	MUTE50/50

#### 7.12.1 Headphone Mute

Configures a digital mute on headphone channel x.

HPxMUTE	Headphone Mute
0	Disabled
1	Enabled

#### 7.12.2 Speaker Mute

Configures a digital mute on speaker channel x.

SPKxMUTE	Speaker Mute
0	Disabled
1	Enabled

#### 7.12.3 Speaker Volume Setting B=A

Configures independent or ganged volume control of the speaker volume. Mute is not affected.

SPKB=A	Single Volume Control for the Speaker Channel
0	Disabled
1	Enabled

#### 7.12.4 Speaker Channel Swap

Configures a channel swap on the speaker channels.

SPKSWAP	Speaker Output
0	Channel A
1	Channel B
<b>Application:</b>	“ <a href="#">Mono Speaker Output Configuration</a> ” on page 27

### 7.12.5 Speaker MONO Control

Configures a parallel full bridge output for the speaker channels.

<b>SPKMONO</b>	<b>Parallel Full Bridge Output</b>
0	Disabled
1	Enabled
<b>Application:</b>	<a href="#">"Mono Speaker Output Configuration" on page 27</a>

### 7.12.6 Speaker Mute 50/50 Control

Configures how the speaker channels mute.

<b>MUTE50/50</b>	<b>Speaker Mute 50/50</b>
0	Disabled; The PWM amplifiers outputs modulated silence when SPKxMUTE is enabled.
1	Enabled; The PWM amplifiers switch at an exact 50%-duty-cycle signal (not modulated) when SPKxMUTE is enabled.

## 7.13 Passthrough x Volume: PASSAVOL (Address 14h) & PASSBVOL (Address 15h)

7	6	5	4	3	2	1	0
PASSxVOL7	PASSxVOL6	PASSxVOL5	PASSxVOL4	PASSxVOL3	PASSxVOL2	PASSxVOL1	PASSxVOL0

### 7.13.1 Passthrough x Volume

Sets the volume/gain of the analog input signal routed to the headphone/line output.

<b>PASSxVOL[7:0]</b>	<b>Gain</b>
0111 1111	12 dB
...	...
0001 1000	12 dB
...	...
0000 0001	+0.5 dB
0000 0000	0 dB
11111 1111	-0.5 dB
...	...
1000 1000	-60.0 dB
...	...
1000 0000	-60.0 dB
<b>Step Size:</b>	0.5 dB (approximate)
<b>Application:</b>	<a href="#">"Passthrough Analog" on page 44</a>

#### Notes:

1. This register is ignored when the PASSTHRUx bit (["Passthrough Analog" on page 44](#)) is disabled.
2. The step size may deviate from 0.5 dB at settings below -40 dB. Code settings 0x95, 0xA1, 0xAD and 0xB9 are not guaranteed to be monotonic.

**7.14 PCMx Volume: PCMA (Address 1Ah) & PCMB (Address 1Bh)**

7	6	5	4	3	2	1	0
PCMxMUTE	PCMxVOL6	PCMxVOL5	PCMxVOL4	PCMxVOL3	PCMxVOL2	PCMxVOL1	PCMxVOL0

**7.14.1 PCM Channel x Mute**

Configures a digital mute on the PCM data from the serial data input (SDIN) to the DSP.

PCMxMUTE	PCM Mute
0	Disabled
1	Enabled

**7.14.2 PCM Channel x Volume**

Sets the volume/gain of the PCM data from the serial data input (SDIN) to the DSP.

PCMxVOL[6:0]	Volume
001 1000	+12.0 dB
...	...
000 0001	+0.5 dB
000 0000	0 dB
111 1111	-0.5 dB
...	...
001 1001	-51.5 dB
Step Size:	0.5 dB

**7.15 Beep Frequency & On Time (Address 1Ch)**

7	6	5	4	3	2	1	0
FREQ3	FREQ2	FREQ1	FREQ0	ONTIME3	ONTIME2	ONTIME1	ONTIME0

**7.15.1 Beep Frequency**

Sets the frequency of the beep signal.

FREQ[3:0]	Frequency ( $F_s = 12, 24, 48$ or $96$ kHz)	Pitch
0000	260.87 Hz	C4
0001	521.74 Hz	C5
0010	585.37 Hz	D5
0011	666.67 Hz	E5
0100	705.88 Hz	F5
0101	774.19 Hz	G5
0110	888.89 Hz	A5
0111	1000.00 Hz	B5
1000	1043.48 Hz	C6
1001	1200.00 Hz	D6
1010	1333.33 Hz	E6
1011	1411.76 Hz	F6
1100	1600.00 Hz	G6
1101	1714.29 Hz	A6
1110	2000.00 Hz	B6
1111	2181.82 Hz	C7
Application:	<a href="#">"Beep Generator" on page 22</a>	

**Notes:**

1. This setting must not change when BEEP is enabled.
2. Beep frequency will scale directly with sample rate,  $F_s$ , but is fixed at the nominal  $F_s$  within each speed mode.

### 7.15.2 Beep On Time

Sets the on duration of the beep signal.

ONTIME[3:0]	On Time ( $F_s = 12, 24, 48$ or $96$ kHz)
0000	~86 ms
0001	~430 ms
0010	~780 ms
0011	~1.20 s
0100	~1.50 s
0101	~1.80 s
0110	~2.20 s
0111	~2.50 s
1000	~2.80 s
1001	~3.20 s
1010	~3.50 s
1011	~3.80 s
1100	~4.20 s
1101	~4.50 s
1110	~4.80 s
1111	~5.20 s
<b>Application:</b>	"Beep Generator" on page 22

**Notes:**

1. This setting must not change when BEEP is enabled.
2. Beep on time will scale inversely with sample rate,  $F_s$ , but is fixed at the nominal  $F_s$  within each speed mode.

### 7.16 Beep Volume & Off Time (Address 1Dh)

7	6	5	4	3	2	1	0
OFFTIME2	OFFTIME1	OFFTIME0	BPVOL4	BPVOL3	BPVOL2	BPVOL1	BPVOL0

#### 7.16.1 Beep Off Time

Sets the off duration of the beep signal.

OFFTIME[2:0]	Off Time ( $F_s = 48$ or $96$ kHz)
000	~1.23 s
001	~2.58 s
010	~3.90 s
011	~5.20 s
100	~6.60 s
101	~8.05 s
110	~9.35 s
111	~10.80 s
<b>Application:</b>	"Beep Generator" on page 22

**Notes:**

1. This setting must not change when BEEP is enabled.
2. Beep off time will scale inversely with sample rate, Fs, but is fixed at the nominal Fs within each speed mode.

### 7.16.2 Beep Volume

Sets the volume of the beep signal.

BEEPVOL[4:0]	Gain
00110	+6.0 dB
...	...
00000	-6 dB
11111	-8 dB
11110	-10 dB
...	...
00111	-56 dB
<b>Step Size:</b>	2 dB
<b>Application:</b>	"Beep Generator" on page 22

**Note:** This setting must not change when BEEP is enabled.

## 7.17 Beep & Tone Configuration (Address 1Eh)

7	6	5	4	3	2	1	0
BEEP1	BEEP0	BEEPMIXDIS	TREBCF1	TREBCF0	BASSCF1	BASSCF0	TCEN

### 7.17.1 Beep Configuration

Configures a beep mixed with the HP/Line and SPK output.

BEEP[1:0]	Beep Occurrence
00	Off
01	Single
10	Multiple
11	Continuous
<b>Application:</b>	"Beep Generator" on page 22

**Notes:**

1. When used in analog pass through mode, the output alternates between the signal from the Passthrough Amplifier and the beep signal. The beep signal does not mix with the analog signal from the Passthrough Amplifier.
2. Re-engaging the beep before it has completed its initial cycle will cause the beep signal to remain ON for the maximum ONTIME duration.

### 7.17.2 Beep Mix Disable

Configures how the beep mixes with the serial data input.

BEEPMIXDIS	Beep Output to HP/Line and Speaker
0	Mix Enabled; The beep signal mixes with the digital signal from the serial data input.
1	Mix Disabled; The output alternates between the signal from the serial data input and the beep signal. The beep signal does not mix with the digital signal from the serial data input.
<b>Application:</b>	"Beep Generator" on page 22

**Note:** This setting must not change when BEEP is enabled.

### 7.17.3 Treble Corner Frequency

Sets the corner frequency (-3 dB point) for the treble shelving filter.

TREBCF[1:0]	Treble Corner Frequency Setting
00	5 kHz
01	7 kHz
10	10 kHz
11	15 kHz

### 7.17.4 Bass Corner Frequency

Sets the corner frequency (-3 dB point) for the bass shelving filter.

BASSCF[1:0]	Bass Corner Frequency Setting
00	50 Hz
01	100 Hz
10	200 Hz
11	250 Hz

### 7.17.5 Tone Control Enable

Configures the treble and bass activation.

TCEN	Bass and Treble Control
0	Disabled
1	Enabled
<b>Application:</b>	<a href="#">"Beep Generator" on page 22</a>

## 7.18 Tone Control (Address 1Fh)

7	6	5	4	3	2	1	0
TREB3	TREB2	TREB1	TREB0	BASS3	BASS2	BASS1	BASS0

### 7.18.1 Treble Gain

Sets the gain of the treble shelving filter.

TREB[3:0]	Gain Setting
0000	+12.0 dB
...	...
0111	+1.5 dB
1000	0 dB
1001	-1.5 dB
...	...
1111	-10.5 dB
<b>Step Size:</b>	1.5 dB

### 7.18.2 Bass Gain

Sets the gain of the bass shelving filter.

TREB[3:0]	Gain Setting
0000	+12.0 dB
...	...
0111	+1.5 dB
1000	0 dB
1001	-1.5 dB
...	...
1111	-10.5 dB
<b>Step Size:</b>	1.5 dB

### 7.19 Master Volume Control: MSTA (Address 20h) & MSTB (Address 21h)

7	6	5	4	3	2	1	0
MSTxVOL7	MSTxVOL6	MSTxVOL5	MSTxVOL4	MSTxVOL3	MSTxVOL2	MSTxVOL1	MSTxVOL0

#### 7.19.1 Master Volume Control

Sets the volume of the signal out the DSP.

MSTxVOL[7:0]	Master Volume
0001 1000	+12.0 dB
...	...
0000 0000	0 dB
1111 1111	-0.5 dB
1111 1110	-1.0 dB
...	...
0011 0100	-102 dB
...	...
0001 1001	-102 dB
<b>Step Size:</b>	0.5 dB

### 7.20 Headphone Volume Control: HPA (Address 22h) & HPB (Address 23h)

7	6	5	4	3	2	1	0
HPxVOL7	HPxVOL6	HPxVOL5	HPxVOL4	HPxVOL3	HPxVOL2	HPxVOL1	HPxVOL0

#### 7.20.1 Headphone Volume Control

Sets the volume of the signal out the DAC.

HPxVOL[7:0]	Headphone Volume
0000 0000	0 dB
1111 1111	-0.5 dB
1111 1110	-1.0 dB
...	...
0011 0100	-96.0 dB
...	...
0000 0001	Muted
<b>Step Size:</b>	0.5 dB

## 7.21 Speaker Volume Control: SPKA (Address 24h) & SPKB (Address 25h)

7	6	5	4	3	2	1	0
SPKxVOL7	SPKxVOL6	SPKxVOL5	SPKxVOL4	SPKxVOL3	SPKxVOL2	SPKxVOL1	SPKxVOL0

### 7.21.1 Speaker Volume Control

Sets the volume of the signal out the PWM modulator.

SPKxVOL[7:0]	Speaker Volume
0000 0000	0 dB
1111 1111	-0.5 dB
1111 1110	-1.0 dB
...	...
0100 0000	-96.0 dB
...	...
0000 0001	Muted
<b>Step Size:</b>	0.5 dB

**Note:** The maximum step size error is +/-0.15 dB.

## 7.22 PCM Channel Swap (Address 26h)

7	6	5	4	3	2	1	0
PCMASWP1	PCMASWP0	PCMBSWP1	PCMBSWP0	Reserved	Reserved	Reserved	Reserved

### 7.22.1 PCM Channel Swap

Configures a mix/swap of the PCM data to the headphone/line or speaker outputs.

PCMxSWP[1:0]	PCM to HP/LINEOUTA	PCM to HP/LINEOUTB
00	Left	Right
01	(Left + Right)/2	(Left + Right)/2
10		
11	Right	Left

## 7.23 Limiter Control 1, Min/Max Thresholds (Address 27h)

7	6	5	4	3	2	1	0
LMAX2	LMAX1	LMAX0	CUSH2	CUSH1	CUSH0	LIMSRDIS	LIMZCDIS

### 7.23.1 Limiter Maximum Threshold

Sets the maximum level, below full scale, at which to limit and attenuate the output signal at the attack rate (LIMARATE - [“Limiter Release Rate” on page 54](#)).

LMAX[2:0]	Threshold Setting
000	0 dB
001	-3 dB
010	-6 dB
011	-9 dB
100	-12 dB
101	-18 dB
110	-24 dB
111	-30 dB
<b>Application:</b>	<a href="#">“Limiter” on page 22</a>

**Note:** Bass, Treble and digital gain settings that boost the signal beyond the maximum threshold may trigger an attack.

### 7.23.2 Limiter Cushion Threshold

Sets the minimum level at which to disengage the Limiter’s attenuation at the release rate (LIMRRATE - [“Limiter Release Rate” on page 54](#)) until levels lie between the LMAX and CUSH thresholds.

CUSH[2:0]	Threshold Setting
000	0 dB
001	-3 dB
010	-6 dB
011	-9 dB
100	-12 dB
101	-18 dB
110	-24 dB
111	-30 dB
<b>Application:</b>	<a href="#">“Limiter” on page 22</a>

**Note:** This setting is usually set slightly below the LMAX threshold.

### 7.23.3 Limiter Soft Ramp Disable

Configures an override of the digital soft ramp setting.

LIMSRDIS	Limiter Soft Ramp Disable
0	OFF; Limiter Attack Rate is dictated by the DIGSFT ( <a href="#">“Digital Soft Ramp” on page 44</a> ) setting
1	ON; Limiter volume changes take effect in one step, regardless of the DIGSFT setting.
<b>Application:</b>	<a href="#">“Limiter” on page 22</a>

**Note:** This bit is ignored when the DIGZC ([“Digital Zero Cross” on page 45](#)) is enabled.

### 7.23.4 Limiter Zero Cross Disable

Configures an override of the digital zero cross setting.

<b>LIMZCDIS</b>	<b>Limiter Zero Cross Disable</b>
0	OFF; Limiter Attack Rate is dictated by the DIGZC (“Digital Zero Cross” on page 45) setting
1	ON; Limiter volume changes take effect in one step, regardless of the DIGZC setting.
<b>Application:</b>	“Limiter” on page 22

## 7.24 Limiter Control 2, Release Rate (Address 28h)

7	6	5	4	3	2	1	0
LIMIT	LIMIT_ALL	LIMRRATE5	LIMRRATE4	LIMRRATE3	LIMRRATE2	LIMRRATE1	LIMRRATE0

### 7.24.1 Peak Detect and Limiter

Configures the peak detect and limiter circuitry.

<b>LIMIT</b>	<b>Limiter Status</b>
0	Disabled
1	Enabled
<b>Application:</b>	“Limiter” on page 22

### 7.24.2 Peak Signal Limit All Channels

Sets how channels are attenuated when the limiter is enabled.

<b>LIMIT_ALL</b>	<b>Limiter action:</b>
0	Apply the necessary attenuation on a specific channel only when the signal amplitude on <i>that</i> specific channel rises above LMAX. Remove attenuation on a specific channel only when the signal amplitude on <i>that</i> specific channel falls below CUSH.
1	Apply the necessary attenuation on BOTH channels when the signal amplitude on any ONE channel rises above LMAX. Remove attenuation on BOTH channels only when the signal amplitude on BOTH channels fall below CUSH.
<b>Application:</b>	“Limiter” on page 22

### 7.24.3 Limiter Release Rate

Sets the rate at which the limiter releases the digital attenuation from levels below the CUSH[2:0] threshold (“Limiter Cushion Threshold” on page 53) and returns the analog output level to the MSTxVOL[7:0] (“Master Volume Control” on page 51) setting.

<b>LIMRRATE[5:0]</b>	<b>Release Time</b>
00 0000	Fastest Release
...	...
11 1111	Slowest Release
<b>Application:</b>	“Limiter” on page 22

**Note:** The limiter release rate is user-selectable but is also a function of the sampling frequency, Fs, and the DIGSFT (“Digital Soft Ramp” on page 44) and DIGZC (“Digital Zero Cross” on page 45) setting.

## 7.25 Limiter Attack Rate (Address 29h)

7	6	5	4	3	2	1	0
Reserved	Reserved	LIMARATE5	LIMARATE4	LIMARATE3	LIMARATE2	LIMARATE1	LIMARATE0

### 7.25.1 Limiter Attack Rate

Sets the rate at which the limiter applies digital attenuation from levels above the MAX[2:0] threshold (“Limiter Maximum Threshold” on page 53).

LIMARATE[5:0]	Attack Time
00 0000	Fastest Attack
...	...
11 1111	Slowest Attack
<b>Application:</b>	“Limiter” on page 22

**Note:** The limiter attack rate is user-selectable but is also a function of the sampling frequency,  $F_s$ , and the DIGSFT (“Digital Soft Ramp” on page 44) and DIGZC (“Digital Zero Cross” on page 45) setting unless the respective disable bit (“Limiter Soft Ramp Disable” on page 53 or “Limiter Zero Cross Disable” on page 54) is enabled.

## 7.26 Status (Address 2Eh) (Read Only)

For all bits in this register, a “1” means the associated error condition has occurred at least once since the register was last read. A “0” means the associated error condition has NOT occurred since the last reading of the register. Reading the register resets all bits to 0.

7	6	5	4	3	2	1	0
Reserved	SPCLKERR	DSPAOVFL	DSPBOVFL	PCMAOVFL	PCMBOVFL	Reserved	Reserved

### 7.26.1 Serial Port Clock Error (Read Only)

Indicates the status of the MCLK to LRCK ratio.

SPCLKERR	Serial Port Clock Status:
0	MCLK/LRCK ratio is valid.
1	MCLK/LRCK ratio is not valid.
<b>Application:</b>	“Serial Port Clocking” on page 29

**Note:** On initial power up and application of clocks, this bit will report ‘1’b as the serial port re-synchronizes.

### 7.26.2 DSP Engine Overflow (Read Only)

Indicates the over-range status in the DSP data path.

DSPxOVFL	DSP Overflow Status:
0	No digital clipping has occurred in the data path after the DSP.
1	Digital clipping has occurred in the data path after the DSP.
<b>Application:</b>	“DSP Engine” on page 21

### 7.26.3 PCMx Overflow (Read Only)

Indicates the over-range status in the PCM data path.

PCMxOVFL	PCM Overflow Status:
0	No digital clipping has occurred in the data path of the PCM ("PCM Channel x Volume" on page 47) of the DSP.
1	Digital clipping has occurred in the data path of the PCM of the DSP.
<b>Application:</b>	"DSP Engine" on page 21

## 7.27 Battery Compensation (Address 2Fh)

7	6	5	4	3	2	1	0
BATTCMP	VPMONITOR	Reserved	Reserved	VPREF3	VPREF2	VPREF1	VPREF0

### 7.27.1 Battery Compensation

Configures automatic adjustment of the speaker volume when VP deviates from VPREF[3:0].

BATTCMP	Automatic Battery Compensation
0	Disabled
1	Enabled
<b>Application:</b>	"Maintaining a Desired Output Level" on page 27

### 7.27.2 VP Monitor

Configures the internal ADC that monitors the VP voltage level.

VPMONITOR	VP ADC Status
0	Disabled
1	Enabled

**Notes:**

1. The internal ADC that monitors the VP supply is enabled automatically when BATTCMP is enabled, regardless of the VPMONITOR setting. Conversely, when BATTCMP is disabled, the ADC may be enabled by enabling VPMONITOR; this provides a convenient battery monitor without enabling battery compensation.
2. When enabled, VPMONITOR remains enabled regardless of the PDN bit setting.

### 7.27.3 VP Reference

Sets the desired VP reference used for battery compensation.

VPREF[3:0]	Desired VP used to calculate the required attenuation on the speaker output: (for VA = 1.8 V)
0000	1.5 V
0001	2.0 V
0010	2.5 V
0011	3.0 V
0100	3.5 V
0101	4.0 V
0110	4.5 V
0111	5.0 V
(for VA = 2.5 V)	
1000	1.5 V
1001	2.0 V
1010	2.5 V
1011	3.0 V
1100	3.5 V
1101	4.0 V
1110	4.5 V
1111	5.0 V
<b>Application:</b>	<a href="#">"VP Battery Compensation" on page 27</a>

### 7.28 VP Battery Level (Address 30h) (Read Only)

7	6	5	4	3	2	1	0
VPLVL7	VPLVL6	VPLVL5	VPLVL4	VPLVL3	VPLVL2	VPLVL1	VPLVL0

#### 7.28.1 VP Voltage Level (Read Only)

Indicates the unsigned VP voltage level.

VPLVL[7:0]	VP Voltage
...	
0101 1110	3.0 V (for VA = 2.0 V); apply formula using actual VA voltage to calculate VP voltage.
...	
0111 0010	3.7 V (for VA = 2.0 V); apply formula using actual VA voltage to calculate VP voltage.
...	
<b>Formula:</b>	$VP\ Voltage = (Binary\ representation\ of\ VPLVL[7:0]) * VA / 63.3$

### 7.29 Speaker Status (Address 31h) (Read Only)

7	6	5	4	3	2	1	0
Reserved	Reserved	SPKASHRT	SPKBSHRT	SPKR/HP	Reserved	Reserved	Reserved

#### 7.29.1 Speaker Current Load Status (Read Only)

Indicates whether or not any of the speaker outputs is shorted to ground.

SPKxSHRT	Speaker Output Load
0	No overload detected
1	Overload detected

### 7.29.2 SPKR/HP Pin Status (Read Only)

Indicates the status of the SPKR/HP pin.

SPKR/HP	Pin State
0	Pulled Low
1	Pulled High

### 7.30 Charge Pump Frequency (Address 34h)

7	6	5	4	3	2	1	0
CHGFREQ3	CHGFREQ2	CHGFREQ1	CHGFREQ0	Reserved	Reserved	Reserved	Reserved

#### 7.30.1 Charge Pump Frequency

Sets the charge pump frequency on FLYN and FLYP.

CHGFREQ[3:0]	N
0000	0
...	
0101	5
...	
1111	15
<b>Formula:</b>	<b>Frequency = (64xFs)/(N+2)</b>

**Note:** The headphone output THD+N performance may be affected.

## 8. ANALOG PERFORMANCE PLOTS

### 8.1 Headphone THD+N versus Output Power Plots

Test conditions (unless otherwise specified): Input test signal is a 997 Hz sine wave; measurement bandwidth is 10 Hz to 20 kHz;  $F_s = 48$  kHz.

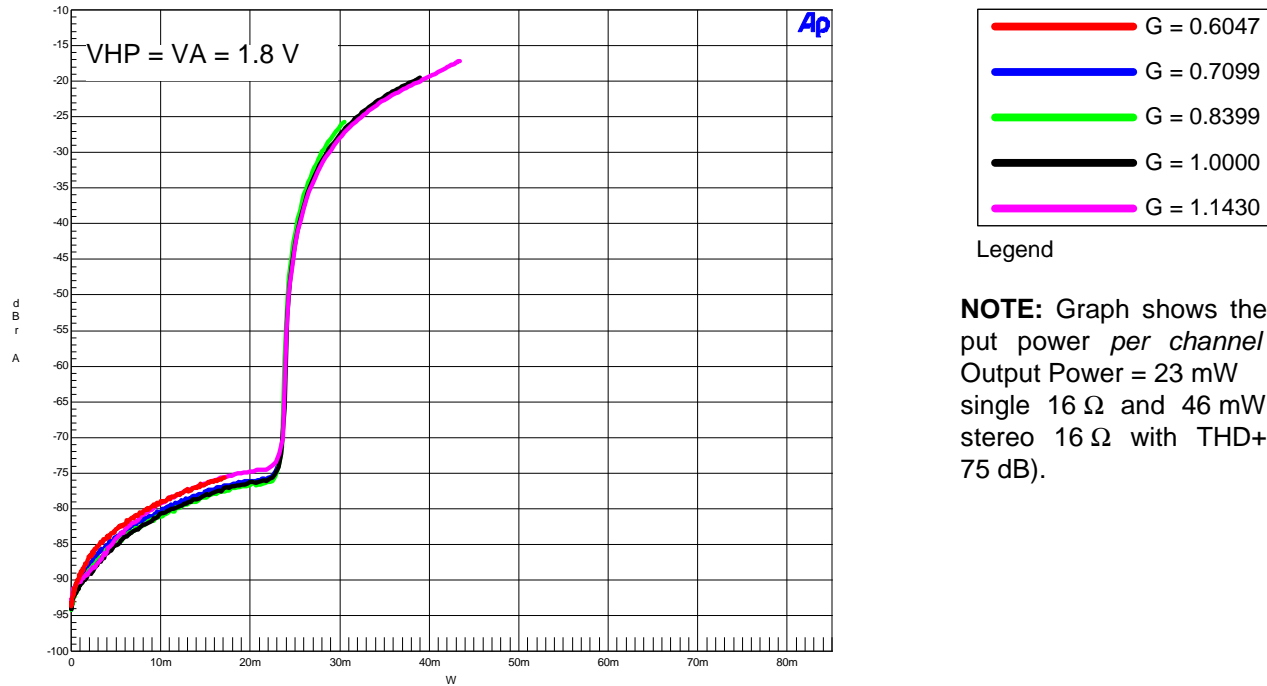

Figure 18. THD+N vs. Output Power per Channel at 1.8 V (16  $\Omega$  load)

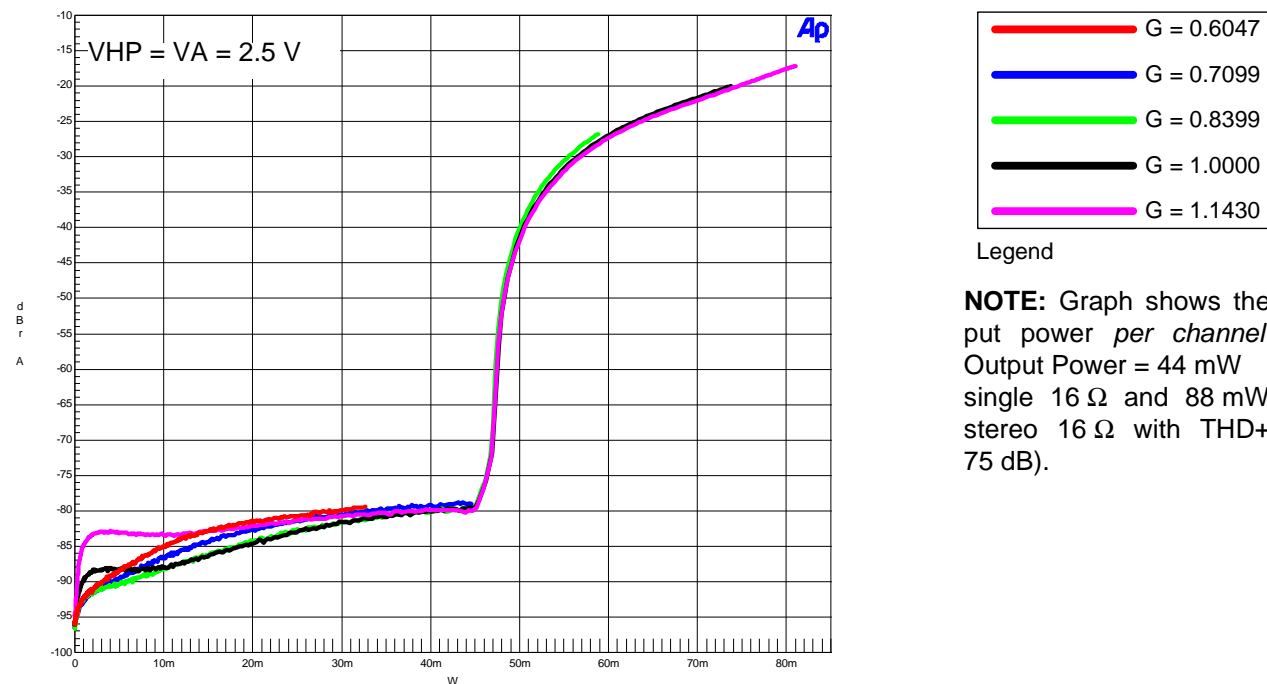
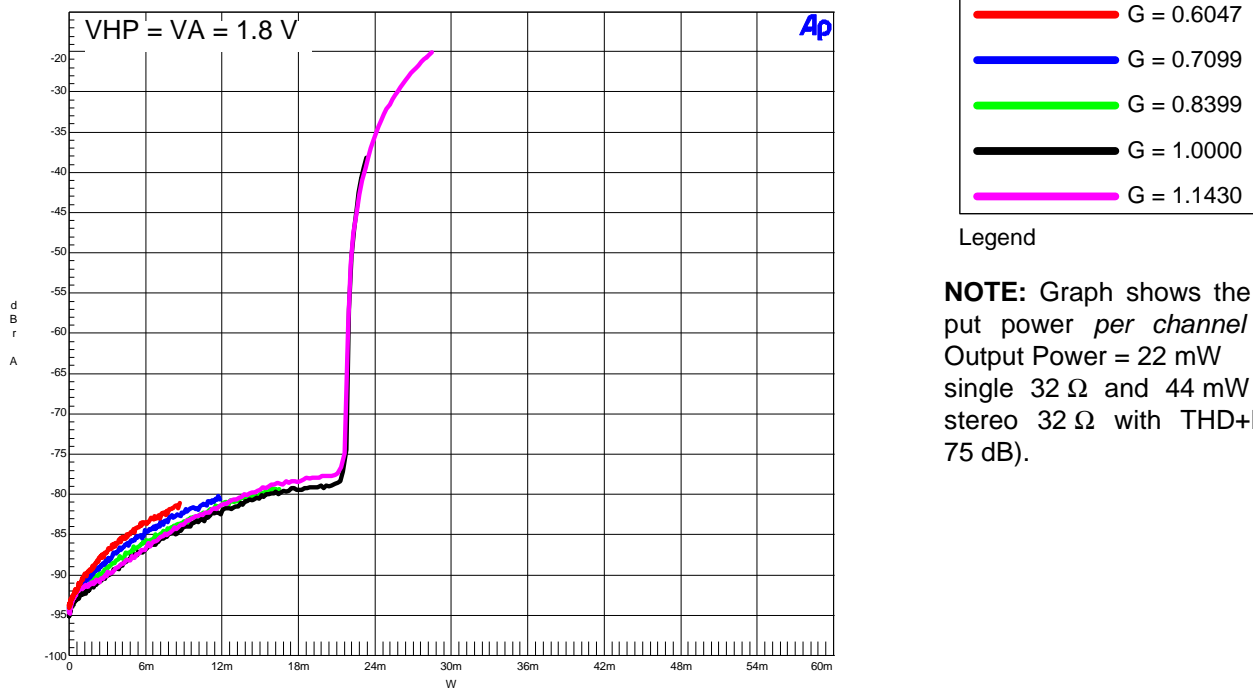
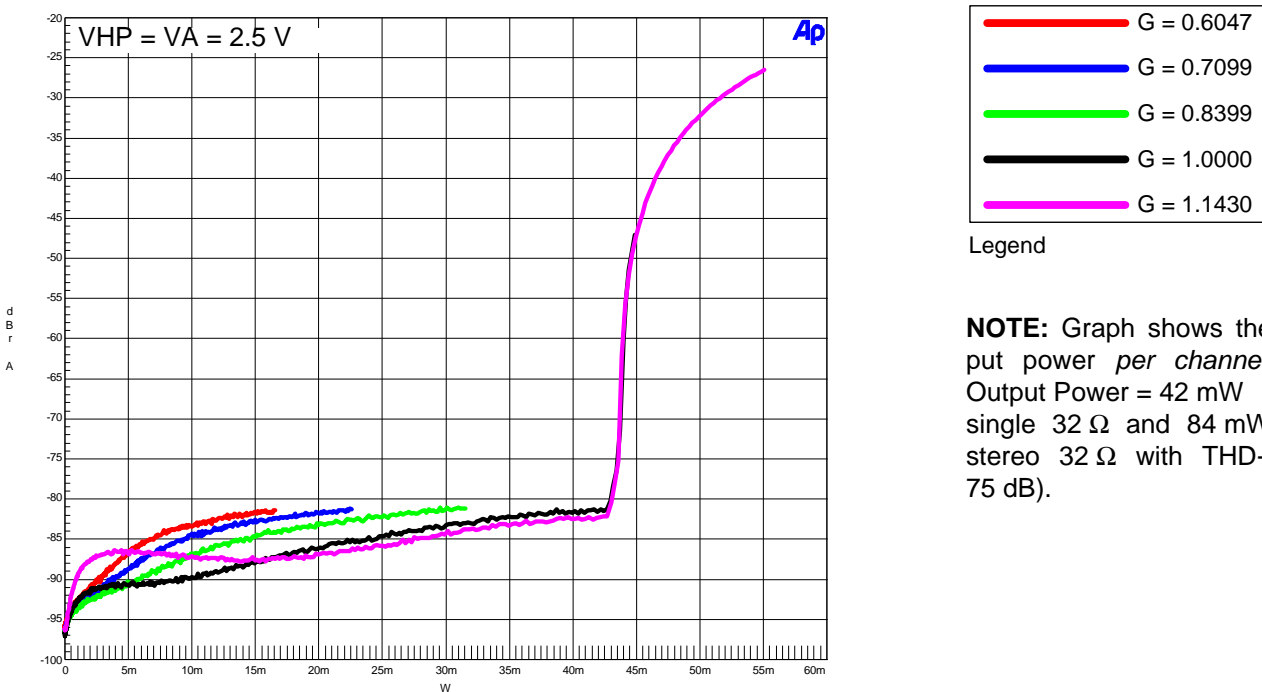

Figure 19. THD+N vs. Output Power per Channel at 2.5 V (16  $\Omega$  load)



**Figure 20. THD+N vs. Output Power per Channel at 1.8 V (32 Ω load)**



**Figure 21. THD+N vs. Output Power per Channel at 2.5 V (32 Ω load)**

**9. EXAMPLE SYSTEM CLOCK FREQUENCIES** \*The "MCLKDIV2" bit must be enabled.

**9.1 Auto Detect Enabled**

Sample Rate LRCK (kHz)	MCLK (MHz)			
	1024x	1536x	2048x*	3072x*
8	8.1920	12.2880	16.3840	24.5760
11.025	11.2896	16.9344	22.5792	33.8688
12	12.2880	18.4320	24.5760	36.8640

Sample Rate LRCK (kHz)	MCLK (MHz)			
	512x	768x	1024x*	1536x*
16	8.1920	12.2880	16.3840	24.5760
22.05	11.2896	16.9344	22.5792	33.8688
24	12.2880	18.4320	24.5760	36.8640

Sample Rate LRCK (kHz)	MCLK (MHz)			
	256x	384x	512x*	768x*
32	8.1920	12.2880	16.3840	24.5760
44.1	11.2896	16.9344	22.5792	33.8688
48	12.2880	18.4320	24.5760	36.8640

Sample Rate LRCK (kHz)	MCLK (MHz)			
	128x	192x	256x*	384x*
64	8.1920	12.2880	16.3840	24.5760
88.2	11.2896	16.9344	22.5792	33.8688
96	12.2880	18.4320	24.5760	36.8640

**9.2 Auto Detect Disabled**

Sample Rate LRCK (kHz)	MCLK (MHz)					
	512x	768x	1024x	1536x	2048x	3072x
8	-	6.1440	8.1920	12.2880	16.3840	24.5760
11.025	-	8.4672	11.2896	16.9344	22.5792	33.8688
12	6.1440	9.2160	12.2880	18.4320	24.5760	36.8640

Sample Rate LRCK (kHz)	MCLK (MHz)					
	256x	384x	512x	768x	1024x	1536x
16	-	6.1440	8.1920	12.2880	16.3840	24.5760
22.05	-	8.4672	11.2896	16.9344	22.5792	33.8688
24	6.1440	9.2160	12.2880	18.4320	24.5760	36.8640

Sample Rate LRCK (kHz)	MCLK (MHz)			
	256x	384x	512x	768x
32	8.1920	12.2880	16.3840	24.5760
44.1	11.2896	16.9344	22.5792	33.8688
48	12.2880	18.4320	24.5760	36.8640

Sample Rate LRCK (kHz)	MCLK (MHz)			
	128x	192x	256x	384x
64	8.1920	12.2880	16.3840	24.5760
88.2	11.2896	16.9344	22.5792	33.8688
96	12.2880	18.4320	24.5760	36.8640

---

## 10. PCB LAYOUT CONSIDERATIONS

### 10.1 Power Supply, Grounding

As with any high-resolution converter, the CS43L22 requires careful attention to power supply and grounding arrangements if its potential performance is to be realized. [Figure 1 on page 9](#) shows the recommended power arrangements, with VA and VHP connected to clean supplies VD, which powers the digital circuitry, may be run from the system logic supply. Alternatively, VD may be powered from the analog supply via a ferrite bead. In this case, no additional devices should be powered from VD.

Extensive use of power and ground planes, ground plane fill in unused areas and surface mount decoupling capacitors are recommended. Decoupling capacitors should be as close to the pins of the CS43L22 as possible. The low value ceramic capacitor should be closest to the pin and should be mounted on the same side of the board as the CS43L22 to minimize inductance effects.

All signals, especially clocks, should be kept away from the FILT+ and VQ pins in order to avoid unwanted coupling into the modulators. The VQ decoupling capacitors, particularly the 0.1  $\mu\text{F}$ , must be positioned to minimize the electrical path from AGND. The CDB43L22 evaluation board demonstrates the optimum layout and power supply arrangements.

### 10.2 QFN Thermal Pad

The CS43L22 is available in a compact QFN package. The underside of the QFN package reveals a large metal pad that serves as a thermal relief to provide for maximum heat dissipation. This pad must mate with an equally dimensioned copper pad on the PCB and must be electrically connected to ground. A series of vias should be used to connect this copper pad to one or more larger ground planes on other PCB layers. In split ground systems, it is recommended that this thermal pad be connected to AGND for best performance. The CS43L22 evaluation board demonstrates the optimum thermal pad and via configuration.

# 11.DIGITAL FILTER PLOTS

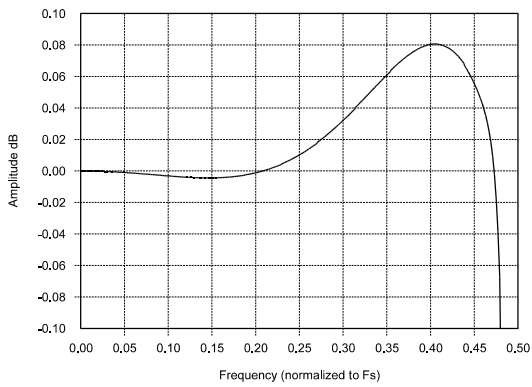

**Figure 22. Passband Ripple**

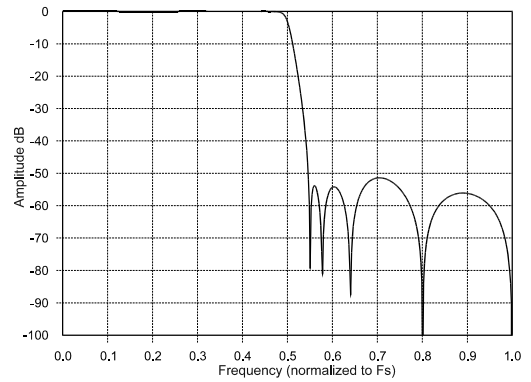

**Figure 23. Stopband**

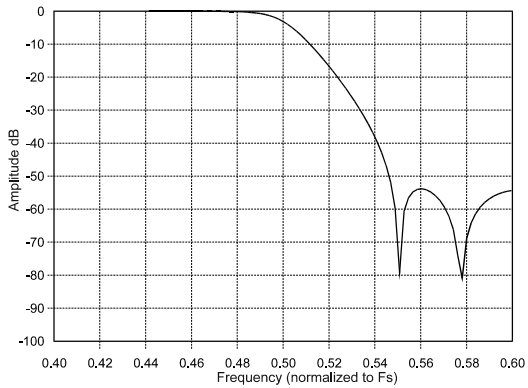

**Figure 24. DAC Transition Band**

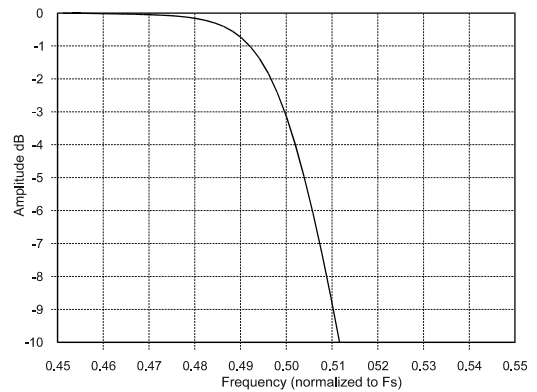

**Figure 25. Transition Band (Detail)**

---

## 12.PARAMETER DEFINITIONS

### Dynamic Range

The ratio of the rms value of the signal to the rms sum of all other spectral components over the specified bandwidth. Dynamic Range is a signal-to-noise ratio measurement over the specified band width made with a -60 dBFS signal. 60 dB is added to resulting measurement to refer the measurement to full-scale. This technique ensures that the distortion components are below the noise level and do not affect the measurement. This measurement technique has been accepted by the Audio Engineering Society, AES17-1991, and the Electronic Industries Association of Japan, EIAJ CP-307. Expressed in decibels.

### Total Harmonic Distortion + Noise

The ratio of the rms value of the signal to the rms sum of all other spectral components over the specified band width (typically 10 Hz to 20 kHz), including distortion components. Expressed in decibels. Measured at -1 and -20 dBFS as suggested in AES17-1991 Annex A.

### Frequency Response

A measure of the amplitude response variation from 10 Hz to 20 kHz relative to the amplitude response at 1 kHz. Units in decibels.

### Interchannel Isolation

A measure of crosstalk between the left and right channel pairs. Measured for each channel at the converter's output with no signal to the input under test and a full-scale signal applied to the other channel. Units in decibels.

### Interchannel Gain Mismatch

The gain difference between left and right channel pairs. Units in decibels.

### Gain Drift

The change in gain value with temperature. Units in ppm/°C.

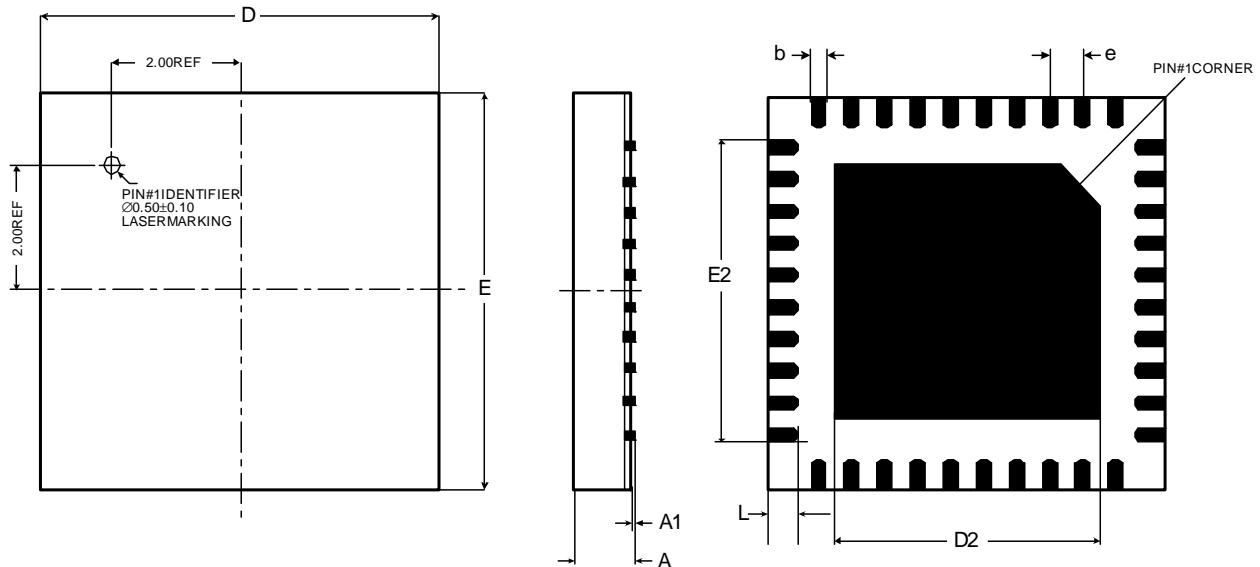
**13.PACKAGE DIMENSIONS**
**40L QFN (6 X 6 mm BODY) PACKAGE DRAWING**

DIM	INCHES			MILLIMETERS			NOTE
	MIN	NOM	MAX	MIN	NOM	MAX	
A	--	--	0.0394	--	--	1.00	1
A1	0.0000	--	0.0020	0.00	--	0.05	1
b	0.0071	0.0091	0.0110	0.18	0.23	0.28	1,2
D	0.2362 BSC			6.00 BSC			1
D2	0.1594	0.1614	0.1634	4.05	4.10	4.15	1
E	0.2362 BSC			6.00 BSC			1
E2	0.1594	0.1614	0.1634	4.05	4.10	4.15	1
e	0.0197 BSC			0.50 BSC			1
L	0.0118	0.0157	0.0197	0.30	0.40	0.50	1

**JEDEC #: MO-220**
*Controlling Dimension is Millimeters.*

1. Dimensioning and tolerance per ASME Y 14.5M-1995.
2. Dimensioning lead width applies to the plated terminal and is measured between 0.20 mm and 0.25 mm from the terminal tip.

**THERMAL CHARACTERISTICS**

Parameter		Symbol	Min	Typ	Max	Units
Junction to Ambient Thermal Impedance	2 Layer Board	$\theta_{JA}$	-	44	-	°C/Watt
	4 Layer Board	$\theta_{JA}$	-	19	-	°C/Watt

## 14. ORDERING INFORMATION

Product	Description	Package	Pb-Free	Grade	Temp Range	Container	Order #
CS43L22	Low-Power Stereo DAC w/HP and Speaker Amps for Portable Apps	40L-QFN	Yes	Commercial	-40 to +85° C	Rail	CS43L22-CNZ
						Tape & Reel	CS43L22-CNZR
CDB43L22	CS43L22 Evaluation Board	-	No	-	-	-	CDB43L22

## 15. REFERENCES

1. Philips Semiconductor, *The I<sup>2</sup>C-Bus Specification: Version 2.1*, January 2000.  
<http://www.semiconductors.philips.com>

## 16. REVISION HISTORY

Revision	Changes
F2	<p>Added AD0 characteristics to "I/O Pin Characteristics" on page 8.</p> <p>Added a description of the AD0 pin to "I<sup>2</sup>C Control" on page 33.</p> <p>Added AD0 detail to Figure 16. Control Port Timing, I<sup>2</sup>C Write on page 33 and Figure 17. Control Port Timing, I<sup>2</sup>C Read on page 33.</p> <p>Updated the first paragraph in "Register Quick Reference" on page 35 and "Register Description" on page 37 to allow for data sheet-specified control-writes to reserved registers.</p> <p>Updated Note 3 on page 11.</p> <p>Removed I<sup>2</sup>C address heading row from "Register Quick Reference" on page 35.</p>

## Contacting Cirrus Logic Support

For all product questions and inquiries, contact a Cirrus Logic Sales Representative.

To find the one nearest you, go to [www.cirrus.com](http://www.cirrus.com).

### IMPORTANT NOTICE

Cirrus Logic, Inc. and its subsidiaries ("Cirrus") believe that the information contained in this document is accurate and reliable. However, the information is subject to change without notice and is provided "AS IS" without warranty of any kind (express or implied). Customers are advised to obtain the latest version of relevant information to verify, before placing orders, that information being relied on is current and complete. All products are sold subject to the terms and conditions of sale supplied at the time of order acknowledgment, including those pertaining to warranty, indemnification, and limitation of liability. No responsibility is assumed by Cirrus for the use of this information, including use of this information as the basis for manufacture or sale of any items, or for infringement of patents or other rights of third parties. This document is the property of Cirrus and by furnishing this information, Cirrus grants no license, express or implied under any patents, mask work rights, copyrights, trademarks, trade secrets or other intellectual property rights. Cirrus owns the copyrights associated with the information contained herein and gives consent for copies to be made of the information only for use within your organization with respect to Cirrus integrated circuits or other products of Cirrus. This consent does not extend to other copying such as copying for general distribution, advertising or promotional purposes, or for creating any work for resale.

CERTAIN APPLICATIONS USING SEMICONDUCTOR PRODUCTS MAY INVOLVE POTENTIAL RISKS OF DEATH, PERSONAL INJURY, OR SEVERE PROPERTY OR ENVIRONMENTAL DAMAGE ("CRITICAL APPLICATIONS"). CIRRUS PRODUCTS ARE NOT DESIGNED, AUTHORIZED OR WARRANTED FOR USE IN PRODUCTS SURGICALLY IMPLANTED INTO THE BODY, AUTOMOTIVE SAFETY OR SECURITY DEVICES, LIFE SUPPORT PRODUCTS OR OTHER CRITICAL APPLICATIONS. INCLUSION OF CIRRUS PRODUCTS IN SUCH APPLICATIONS IS UNDERSTOOD TO BE FULLY AT THE CUSTOMER'S RISK AND CIRRUS DISCLAIMS AND MAKES NO WARRANTY, EXPRESS, STATUTORY OR IMPLIED, INCLUDING THE IMPLIED WARRANTIES OF MERCHANTABILITY AND FITNESS FOR PARTICULAR PURPOSE, WITH REGARD TO ANY CIRRUS PRODUCT THAT IS USED IN SUCH A MANNER. IF THE CUSTOMER OR CUSTOMER'S CUSTOMER USES OR PERMITS THE USE OF CIRRUS PRODUCTS IN CRITICAL APPLICATIONS, CUSTOMER AGREES, BY SUCH USE, TO FULLY INDEMNIFY CIRRUS, ITS OFFICERS, DIRECTORS, EMPLOYEES, DISTRIBUTORS AND OTHER AGENTS FROM ANY AND ALL LIABILITY, INCLUDING ATTORNEYS' FEES AND COSTS, THAT MAY RESULT FROM OR ARISE IN CONNECTION WITH THESE USES.

Cirrus Logic, Cirrus, and the Cirrus Logic logo designs are trademarks of Cirrus Logic, Inc. All other brand and product names in this document may be trademarks or service marks of their respective owners.

I<sup>2</sup>C is a trademark of Philips Semiconductor.

## Looking for pricing, stock, or lifecycle information?

Click below to explore more details on WIN SOURCE:

 [View CS43L22-CNZR on WIN SOURCE](#)

 [Cirrus Logic Inc. Information](#)

## Optimize Your Supply Chain with WIN SOURCE Solutions

-  Global Sourcing Solution
-  Obsolete Management
-  Cost Control Management
-  Shortage Management
-  Alternative Solution
-  Excess Inventory Management