



ON Semiconductor®

<http://onsemi.com>

LC79431KNE

CMOS LSI

Dot-Matrix LCD Drivers

Overview

The LC79431KNE is a large-scale dot matrix LCD common driver LSI. The LC79431KNE contains an 80-bit bidirectional shift register and is equipped with a 4-level LCD driver. The input/output pins for cascade connection can be used to further increase the IC's number of bits. The LC79431KNE can be used in conjunction with segment driver LC79401KNE (QIP100E) to drive a wide-screen LCD panel.

Features

- On-chip LCD drive circuit (80 bits)
- Display duty selection ranging from 1/64 to 1/256
- On-chip input/output pins support a further increases in bit number
- Supports externally supplied bias voltage
- Operating power supply voltage/operating temperature include
 - V_{DD} (Logic section) : 2.7 to 5.5V/-20 to +85°C
 - $V_{DD-V_{EE}}$ (LCD section) : 12 to 32V/-20 to +85°C
- CMOS process
- 100-pin flat plastic package (QIP100E)

LC79431KNE

Specifications

Absolute Maximum Ratings at $T_a = 25 \pm 2^\circ\text{C}$, $V_{SS} = 0\text{V}$

Parameter	Symbol	Conditions	Ratings	unit
Maximum supply voltage (Logic)	V_{DD} max		-0.3 to +7.0	V
Maximum supply voltage (LCD)	$V_{DD}-V_{EE}$ max	*1	0 to 35	V
Maximum input voltage	V_I max		-0.3 to $V_{DD}+0.3$	V
Storage temperature	T_{stg}		-40 to +125	$^\circ\text{C}$

Note *1 The following relations between elements should be maintained: $V_{DD} \geq V_I > V_2 > V_5 > V_{EE}$, $V_{DD}-V_2 \leq 7\text{V}$, $V_5-V_{EE} \leq 7\text{V}$

Stresses exceeding Maximum Ratings may damage the device. Maximum Ratings are stress ratings only. Functional operation above the Recommended Operating Conditions is not implied. Extended exposure to stresses above the Recommended Operating Conditions may affect device reliability.

Allowable Operating Ranges at $T_a = -20$ to $+85^\circ\text{C}$, $V_{SS} = 0\text{V}$

Parameter	Symbol	Conditions	min	typ	max	unit
Supply voltage (Logic)	V_{DD}		2.7		5.5	V
Supply voltage (LCD)	$V_{DD}-V_{EE}$	*2, 3	12		32	V
Input high level voltage	V_{IH}	DIO1, DIO80, CP, M, RS/LS, DISPOFF	$0.8V_{DD}$			V
Input low level voltage	V_{IL}	DIO1, DIO80, CP, M, RS/LS, DISPOFF			$0.2V_{DD}$	V
CP Shift clock	f_{CP}	CP			1	MHz
CP pulse width	t_{WC}	CP	63			ns
Setup time	t_{SETUP}	DIO1 \rightarrow CP, DIO80 \rightarrow CP	100			ns
Hold time	t_{HOLD}	DIO1 \rightarrow CP, DIO80 \rightarrow CP	100			ns
CP rise time	t_R	CP			50	ns
CP fall time	t_F	CP			50	ns

Note *2 The following relations between elements should be maintained: $V_{DD} \geq V_I > V_2 > V_5 > V_{EE}$, $V_{DD}-V_2 \leq 7\text{V}$, $V_5-V_{EE} \leq 7\text{V}$

*3 When the power supply is turned on, power to the LCD driver is turned on after or simultaneously with the turning on of the logic section's power supply. When the power supply is turned off, the logic power supply is turned off after or at the same time the LCD driver power supply is turned off.

Electrical Characteristics at $T_a = 25 \pm 2^\circ\text{C}$, $V_{DD} = 2.7$ to 5.5V

Parameter	Symbol	Conditions	min	typ	max	unit
Input high level current	I_{IH}	$V_{IN}=V_{DD}$, $V_{DD}=5.5\text{V}$, DIO1, DIO80, CP, M, RS/LS, DISPOFF			1	μA
Input low level current	I_{IL}	$V_{IN}=V_{SS}$, $V_{DD}=5.5\text{V}$, DIO1, DIO80, CP, M, RS/LS, DISPOFF	-1			μA
Output high level voltage	V_{OH}	$I_{OH}=-0.4\text{mA}$, DIO1, DIO80	$V_{DD}-0.4$			V
Output low level voltage	V_{OL}	$I_{OL}=0.4\text{mA}$, DIO1, DIO80			0.4	V
Driver on resistance	$R_{ON(1)}$	$V_{DD}-V_{EE}=30\text{V}$, $ V_{DE}-V_{OL} =0.5\text{V}$ $V_{DD}=4.5\text{V}$, O1 to O80 *4			1.0	$\text{k}\Omega$
	$R_{ON(2)}$	$V_{DD}-V_{EE}=20\text{V}$, $ V_{DE}-V_{OL} =0.5\text{V}$ $V_{DD}=4.5\text{V}$, O1 to O80 *4			1.0	$\text{k}\Omega$
Consumable current drain (1)	I_{SS}	$V_{DD}-V_{EE}=30\text{V}$, CP=14kHz no-load, $V_{DD}=5.5\text{V}$; V_{SS}			100	μA
Consumable current drain (2)	I_{EE}	$V_{DD}-V_{EE}=30\text{V}$, CP=14kHz no-load, $V_{DD}=5.5\text{V}$; V_{EE}			100	μA
Input capacitance	C_I	$f=1\text{MHz}$; CP		6		pF

Note *4 $V_{DE} = V_1$ or V_2 or V_5 or V_{EE} , $V_1 = V_{DD}$, $V_2 = 16/17 (V_{DD}-V_{EE})$, $V_5 = 1/17 (V_{DD}-V_{EE})$

Switching Characteristics at $T_a = 25 \pm 2^\circ\text{C}$, $V_{SS} = 0\text{V}$, $V_{DD} = 2.7$ to 5.5V

Parameter	Symbol	Conditions	min	typ	max	unit
Output delay time	t_{PLH}	$C_L=15\text{pF}$; CP \rightarrow DIO1, CP \rightarrow DIO80			250	ns
	t_{PHL}	$C_L=15\text{pF}$; CP \rightarrow DIO1, CP \rightarrow DIO80			250	ns

LC79431KNE

Package Dimensions

unit:mm (typ)

3151A

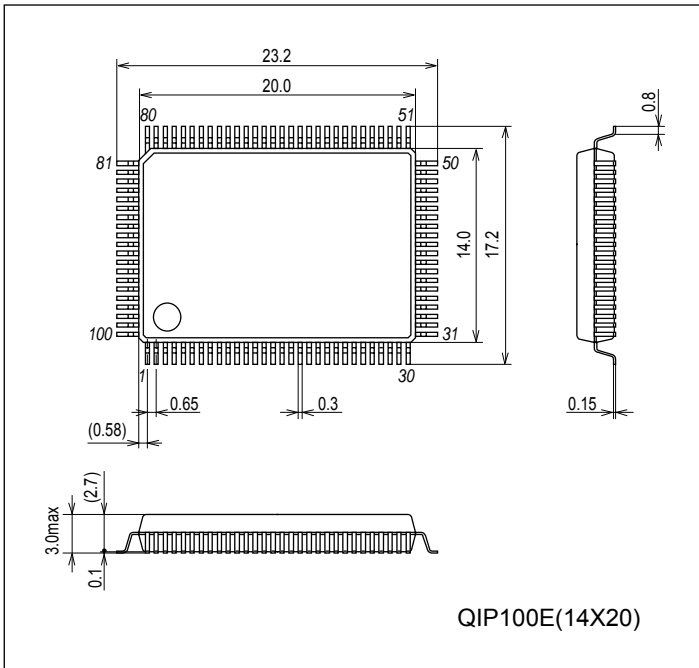

Pin Assignment

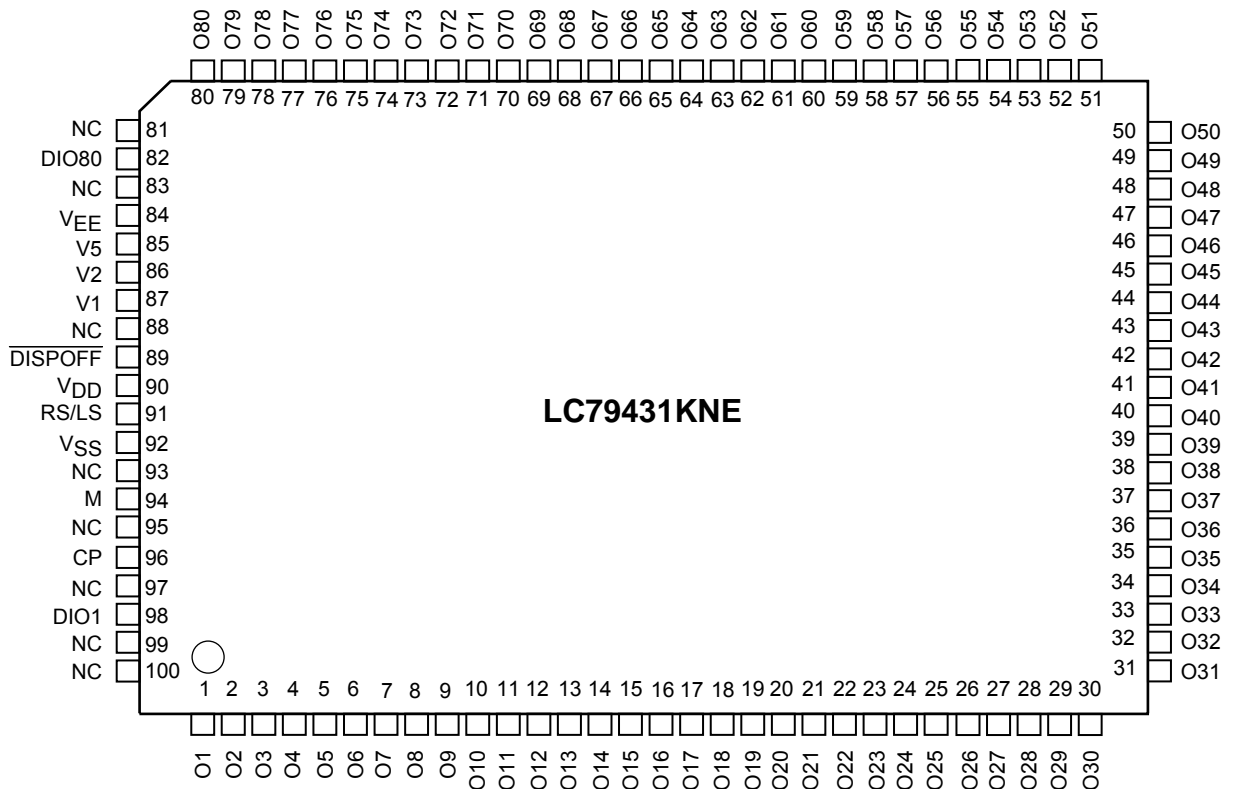

Top view

LC79431KNE

Equivalent Circuit Block Diagram

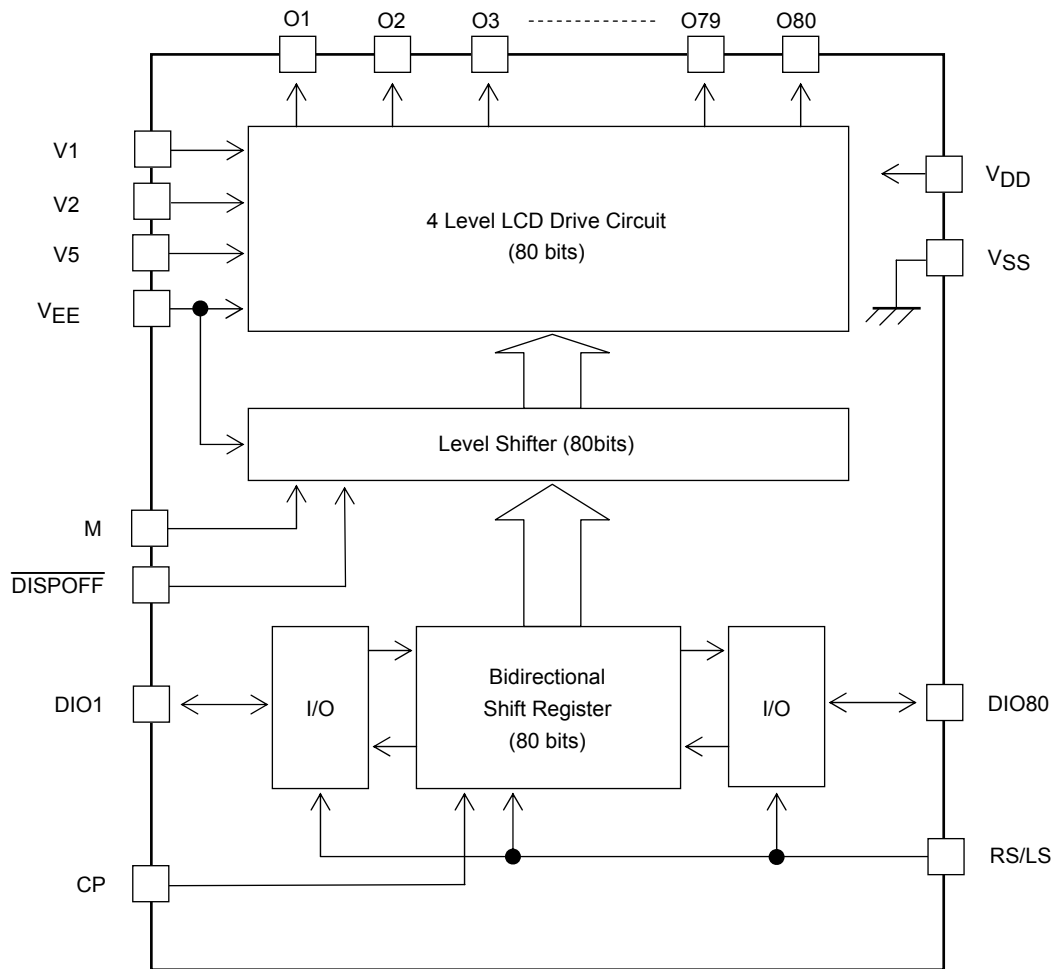

LC79431KNE

Pin Function

Pin No	Symbol	I/O	Function																								
90	V _{DD}	Supply	V _{DD} -V _{SS} : Logic power supply V _{DD} -V _{EE} : LCD drive circuit power supply																								
92	V _{SS}																										
84	V _{EE}																										
87	V1	Supply	LCD drive level power supply V1, V _{EE} : Selected level V2, V5 : Unselected level																								
86	V2																										
85	V5																										
96	CP	I	Bidirectional shift register shift clock (falling edge trigger)																								
98	DIO1	I/O	<table border="1" style="width: 100%; border-collapse: collapse;"> <thead> <tr> <th style="width: 15%;">RS/LS</th> <th style="width: 40%;">Data Transfer Direction</th> <th style="width: 15%;">DIO1</th> <th style="width: 30%;">DIO80</th> </tr> </thead> <tbody> <tr> <td>L (Shift right)</td> <td>O1 → O80</td> <td>IN</td> <td>OUT</td> </tr> <tr> <td>H (Shift left)</td> <td>O80 → O1</td> <td>OUT</td> <td>IN</td> </tr> </tbody> </table>	RS/LS	Data Transfer Direction	DIO1	DIO80	L (Shift right)	O1 → O80	IN	OUT	H (Shift left)	O80 → O1	OUT	IN												
RS/LS	Data Transfer Direction	DIO1		DIO80																							
L (Shift right)	O1 → O80	IN		OUT																							
H (Shift left)	O80 → O1	OUT	IN																								
82	DIO80	I/O																									
91	RS/LS	I																									
94	M	I	LCD drive output alternation signal																								
89	$\overline{\text{DISPOFF}}$	I	O1 to O80 output controlling input pins.																								
1 ⋮ 80	O1 ⋮ O80	O	<p>LCD drive outputs</p> <p>The output levels are determined by the combination of the output the data, The M signal, and the $\overline{\text{DISPOFF}}$ pin as shown in the table.</p> <table border="1" style="width: 100%; border-collapse: collapse;"> <thead> <tr> <th style="width: 15%;">M</th> <th style="width: 20%;">Data</th> <th style="width: 20%;">$\overline{\text{DISPOFF}}$</th> <th style="width: 45%;">Output</th> </tr> </thead> <tbody> <tr> <td>L</td> <td>L</td> <td>H</td> <td>V2</td> </tr> <tr> <td>L</td> <td>H</td> <td>H</td> <td>V_{EE}</td> </tr> <tr> <td>H</td> <td>L</td> <td>H</td> <td>V5</td> </tr> <tr> <td>H</td> <td>H</td> <td>H</td> <td>V1</td> </tr> <tr> <td>*</td> <td>*</td> <td>L</td> <td>V1</td> </tr> </tbody> </table> <p>* Don't care (May be set to either "H" or "L")</p>	M	Data	$\overline{\text{DISPOFF}}$	Output	L	L	H	V2	L	H	H	V _{EE}	H	L	H	V5	H	H	H	V1	*	*	L	V1
M	Data	$\overline{\text{DISPOFF}}$	Output																								
L	L	H	V2																								
L	H	H	V _{EE}																								
H	L	H	V5																								
H	H	H	V1																								
*	*	L	V1																								
81	NC	-	Must be left open.																								
83																											
88																											
93																											
95																											
97																											
99																											
100																											

LC79431KNE

Application Example (LC79401KNE/LC79431KNE)

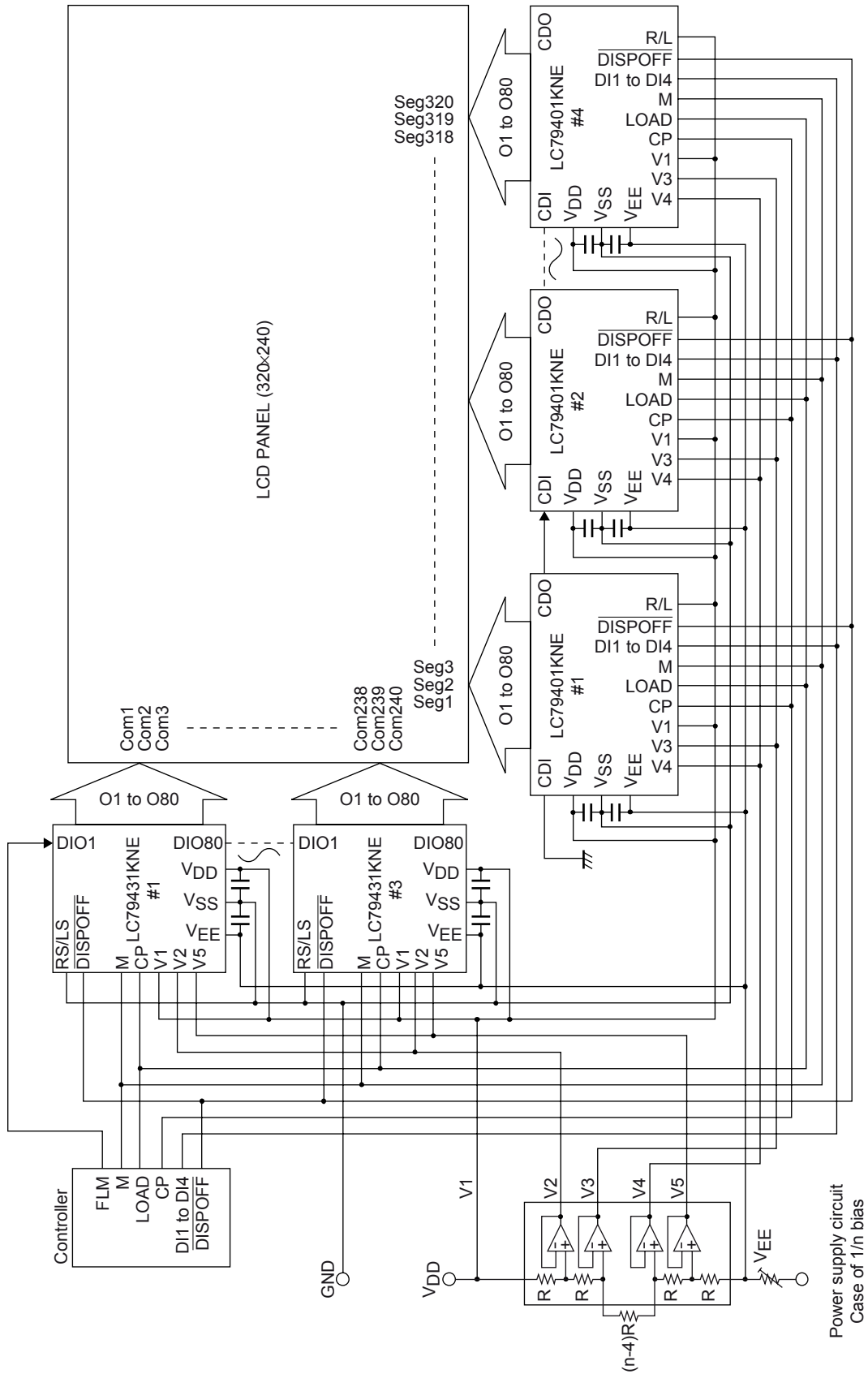

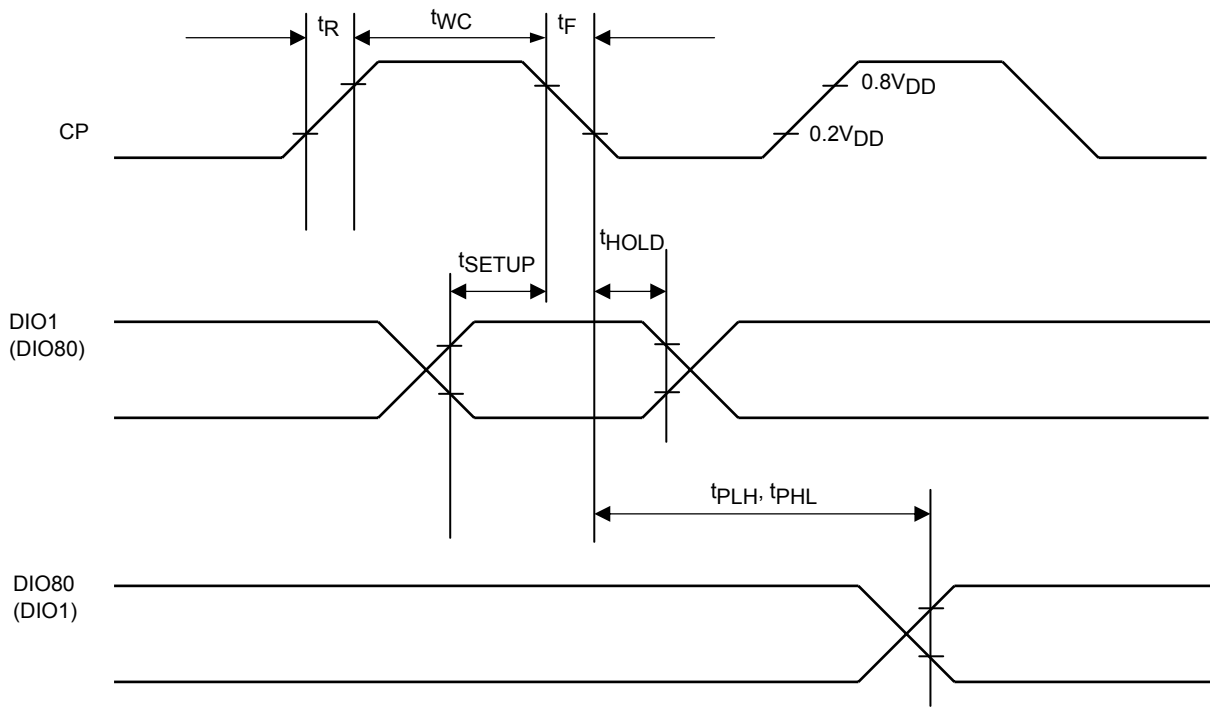

Switching Characteristics Diagram



ON Semiconductor and the ON logo are registered trademarks of Semiconductor Components Industries, LLC (SCILLC). SCILLC owns the rights to a number of patents, trademarks, copyrights, trade secrets, and other intellectual property. A listing of SCILLC's product/patent coverage may be accessed at www.onsemi.com/site/pdf/Patent-Marking.pdf. SCILLC reserves the right to make changes without further notice to any products herein. SCILLC makes no warranty, representation or guarantee regarding the suitability of its products for any particular purpose, nor does SCILLC assume any liability arising out of the application or use of any product or circuit, and specifically disclaims any and all liability, including without limitation special, consequential or incidental damages. "Typical" parameters which may be provided in SCILLC data sheets and/or specifications can and do vary in different applications and actual performance may vary over time. All operating parameters, including "Typicals" must be validated for each customer application by customer's technical experts. SCILLC does not convey any license under its patent rights nor the rights of others. SCILLC products are not designed, intended, or authorized for use as components in systems intended for surgical implant into the body, or other applications intended to support or sustain life, or for any other application in which the failure of the SCILLC product could create a situation where personal injury or death may occur. Should Buyer purchase or use SCILLC products for any such unintended or unauthorized application, Buyer shall indemnify and hold SCILLC and its officers, employees, subsidiaries, affiliates, and distributors harmless against all claims, costs, damages, and expenses, and reasonable attorney fees arising out of, directly or indirectly, any claim of personal injury or death associated with such unintended or unauthorized use, even if such claim alleges that SCILLC was negligent regarding the design or manufacture of the part. SCILLC is an Equal Opportunity/Affirmative Action Employer. This literature is subject to all applicable copyright laws and is not for resale in any manner.

Looking for pricing, stock, or lifecycle information?

Click below to explore more details on WIN SOURCE:

-  [View LC79431KNE-E on WIN SOURCE](#)
-  [ON Semiconductor](#) Information

Optimize Your Supply Chain with WIN SOURCE Solutions

-  Global Sourcing Solution
-  Obsolete Management
-  Cost Control Management
-  Shortage Management
-  Alternative Solution
-  Excess Inventory Management