

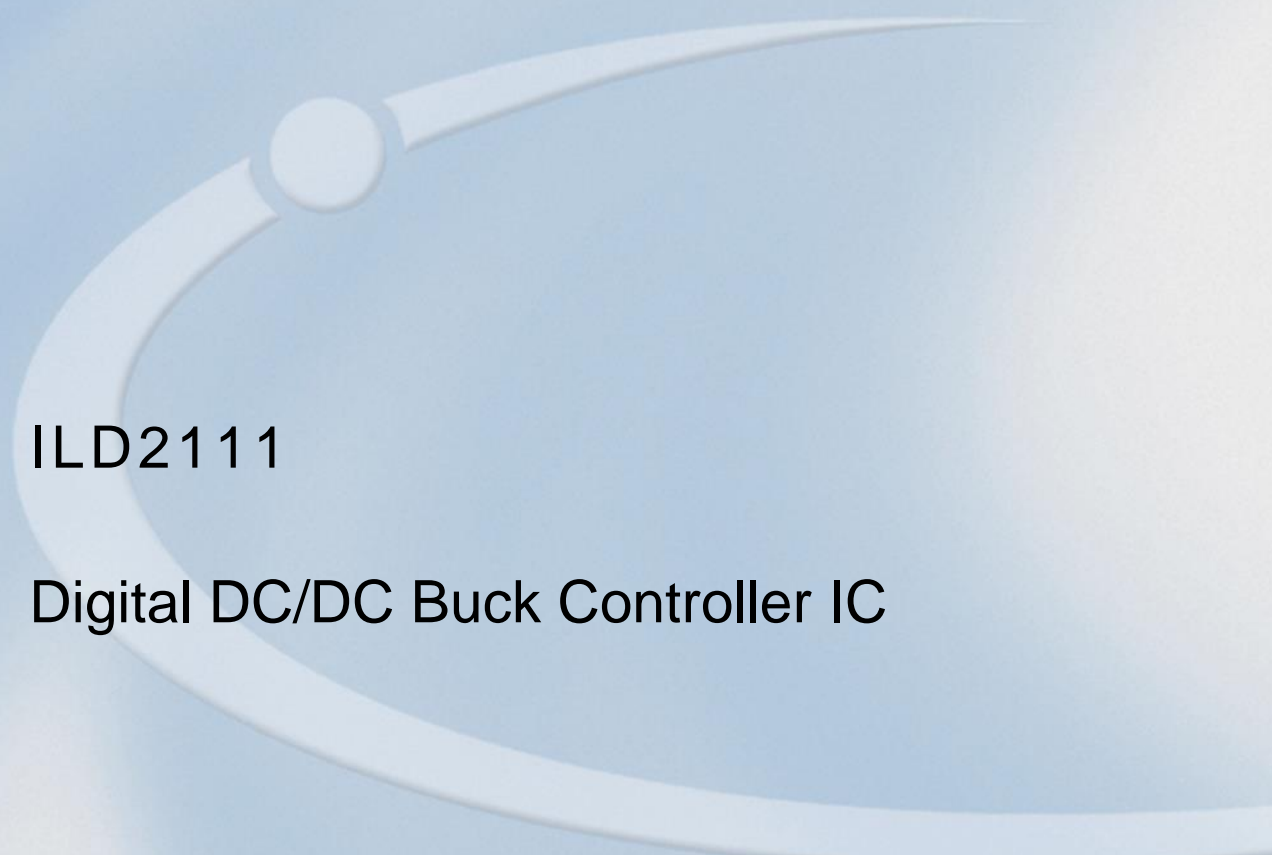

**THE DATASHEET OF
ILD2111XUMA2**



A large, light blue decorative arc with a circular node at its top left, spanning across the middle of the page.

ILD2111

Digital DC/DC Buck Controller IC

Datasheet

Revision 1.0, 2015-04-08

Power Management & Multimarket

Digital DC/DC Controller with I-Set

Product highlights

- Assumes control of functionality where a microcontroller is required in conventional systems
- Device configurable by a comprehensive parameter set
- High efficiency over wide input and output ranges
- High accuracy of +/-5% over output current range and useful temperature

Features

- Hysteretic current regulation
- Output current adjustable in up to 16 steps with a dynamic range of 1:4 between min. and max. configurable by an external resistor
- Flicker-free and phase-aligned PWM dimming based on input PWM signal
- Fully configurable internal and external smart overtemperature protection
- Open/short load protection
- Overpower protection

Applications

- LED drivers, e.g. 2-stage professional lighting systems



- Integrated electronic control gear for LED luminaires

Description

The ILD2111 is a high-performance microcontroller-based digital DC/DC buck LED controller, designed as a constant current source. The driving current is adjustable with a simple external resistor. Flicker-free dimming supported by means of phase-aligned PWM LED current. An ASSP digital microcontroller-based engine is highly configurable using a comprehensive parameter set to provide fine tuning of operation and protection features. High-precision hysteretic output current regulation is achieved thanks to the digital control loops.

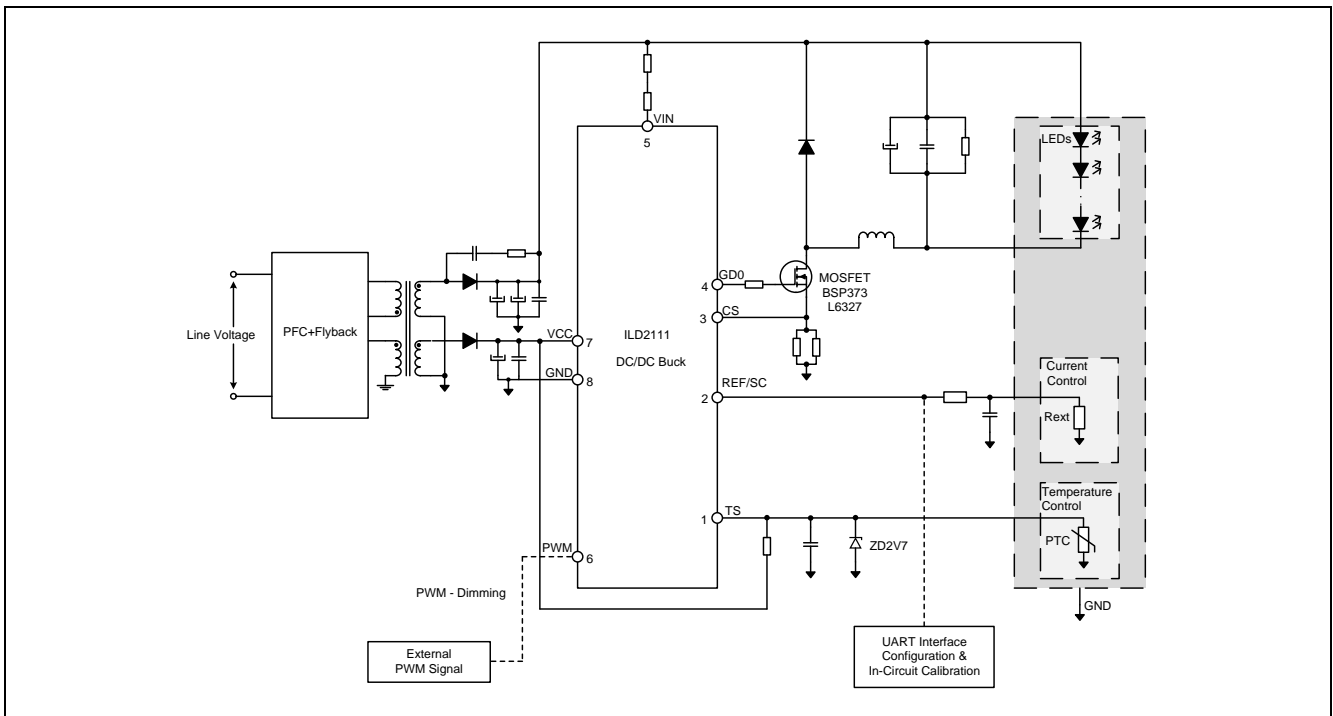

Figure 1. Typical Application

Product type	Package
ILD2111	PG-DSO-8-58

Table of Contents

1	Pin Configuration and Description	4
2	Block Diagram	5
3	Functional Description	6
3.1	Introduction	6
3.2	Main Supply (VCC)	11
3.3	Controller Features	11
3.3.1	Configurable Leading Edge Blanking (LEB) and Sampling Time at Pin CS	12
3.3.2	Configurable Gate Driver Output	12
3.3.3	Reference Current Setup	13
3.3.4	Output Current Control and Measuring	17
3.3.5	Current Startup, Soft-Start and Shutdown Control	19
3.4	Current Ripple vs. Switching Frequency Control Scheme	20
3.4.1	Fixed Current Ripple	20
3.4.2	Frequency and Ripple Control	21
3.5	Input Voltage Measurement and Calibration	28
3.6	Protection Features	30
3.6.1	Undervoltage Protection for DC Input Line – V_{IN} Undervoltage	32
3.6.2	Overvoltage Protection for DC Input Line – V_{IN} Overvoltage	32
3.6.3	Output Undervoltage Protection – V_{OUT} Undervoltage	32
3.6.4	Open Output Protection	32
3.6.5	Output Overvoltage Protection – V_{OUT} Overvoltage	33
3.6.6	Output Overpower Protection – P_{OUT} Overpower	33
3.6.7	Overtemperature Protection	34
3.6.8	Overcurrent Protection – Level 2 (OCP2)	39
3.6.9	Functional Protections	39
3.7	External PWM Dimming	40
3.8	Output Current PWM Modulation	41
3.9	Configuration	42
3.9.1	Overview of Configurable Parameters	42
3.9.2	Configuration Procedure – Parameter Handling	52
4	Electrical Characteristics	54
4.1	Definitions	54
4.2	Absolute Maximum Ratings	55
4.3	Package Characteristics	56
4.4	Operating Conditions	56
4.5	DC Electrical Characteristics	57
5	Outline Dimensions	63

1 Pin Configuration and Description

The pin configuration is shown in [Figure 2](#) and [Table 1-1](#). The pin functions are described later.

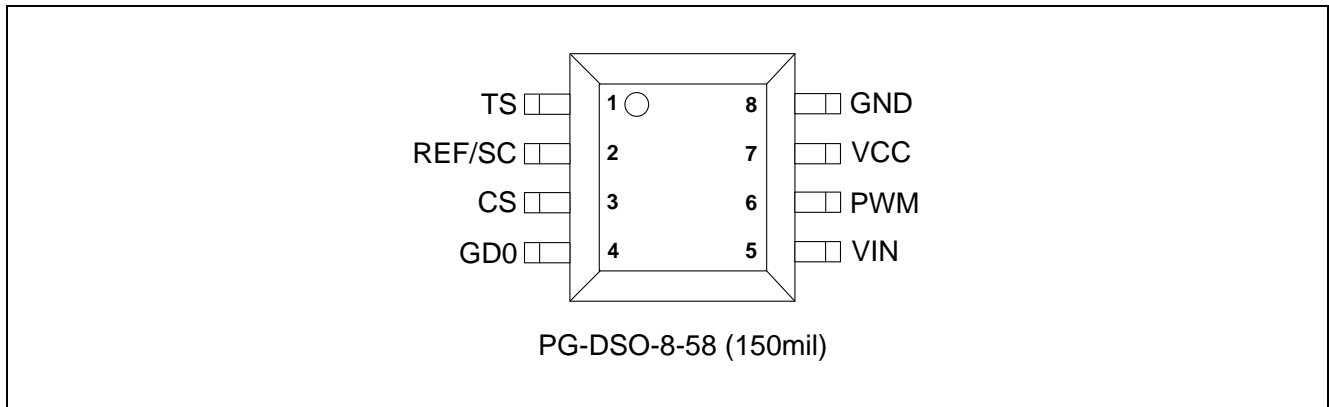

Figure 2. Pin Configuration

Table 1-1. Pin Definitions and Functions

Symbol	Pin	Type	Function
TS	1	I	Temperature Sensor The pin TS is used for external temperature measurement using PTC or an appropriate passive temperature sensor.
REF/SC	2	IO	Reference/Serial Communication The pin REF/SC is multiplexed. During startup it is used for reference current sensing by means of an external RC circuit. Afterwards, it serves as a UART serial communication interface.
CS	3	I	Current Sense Current measurement on an external shunt resistor.
GD0	4	O	Gate Driver Output 0 Output for directly driving a power MOS.
VIN	5	I	Voltage Input Voltage input measurement. Requires an external series resistor for voltage sensing and current limitation.
PWM	6	I	PWM Dimming Signal Input for PWM-based dimming signal.
VCC	7	I	Positive Voltage Supply IC power supply.
GND	8	O	Power and Signal Ground

2 Block Diagram

The block diagram of ILD2111 is shown in [Figure 3](#).

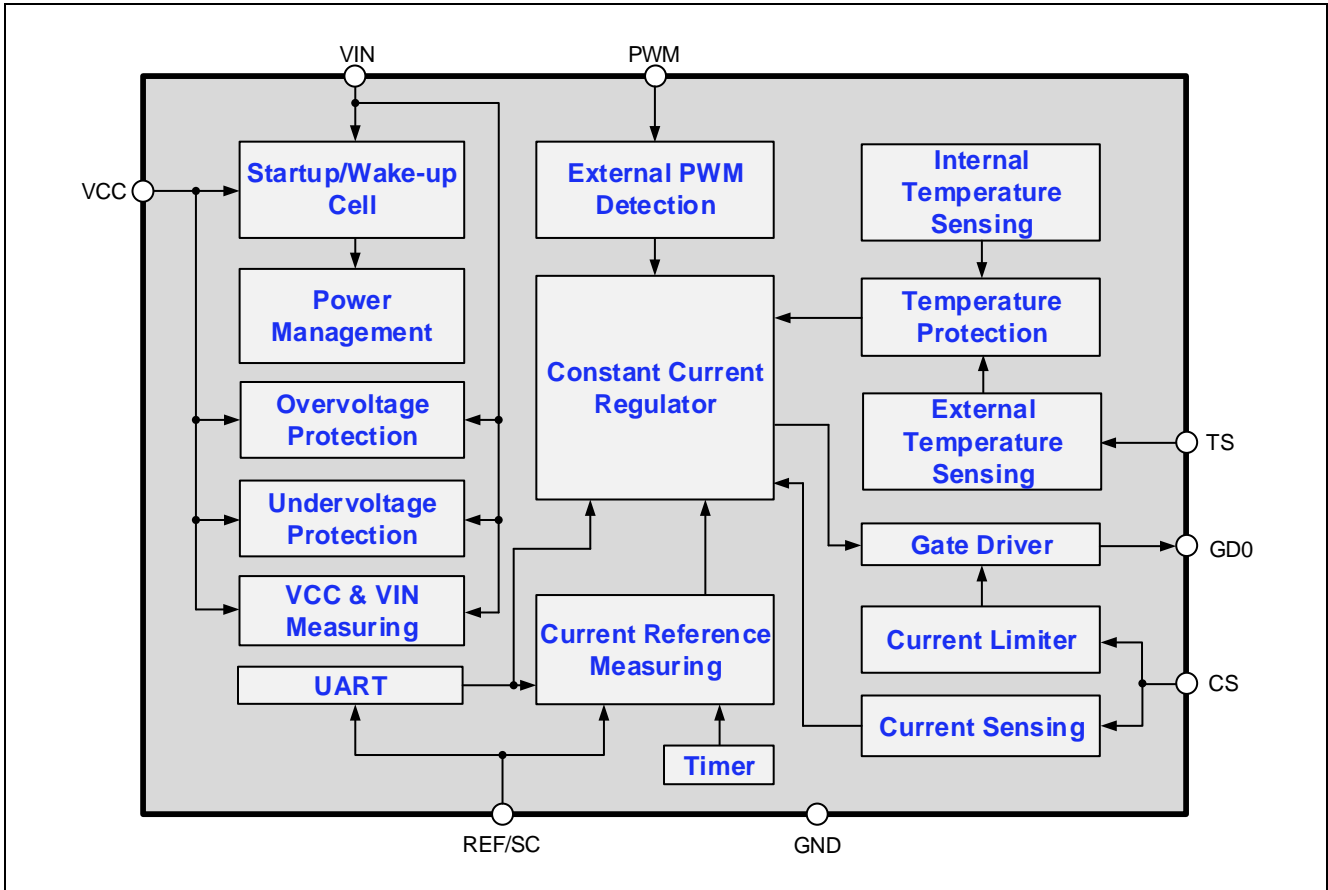

Figure 3. Block Diagram

3 Functional Description

The functional description provides an overview of the integrated functions and features, and their relationship. The parameters and equations provided are based on typical values at $T_A = 25^\circ\text{C}$. The corresponding minimum and maximum values are shown in Section 4, Electrical Characteristics.

3.1 Introduction

The ILD2111 is a high-performance digital microcontroller-based DC/DC buck LED controller designed as a constant current source with hysteretic output current regulation. The controller typically uses a floating buck topology operating in a Continuous Conduction Mode (CCM). In order to reduce switching losses and increase efficiency, as well as to control the switching frequency over a wide variety of external component values, input voltage and load variations, a frequency ripple control is introduced. Both internal and external temperature measurements are implemented and accompanied with an intelligent temperature protection algorithm with two threshold values. The controller utilizes a variety of protection features, including overpower, open and short load conditions. The ILD2111 is a dimmable device controlled by an external PWM signal. The device can be parameterized by means of a single pin UART interface at the REF/SC pin (see Section 3.9). A complete top-level device operation process, including protection and error handling, is shown in Figure 4. Table 3-1 shows device operating statuses, buck statuses associated with the buck state machine, as well as error and associated error codes. The buck state machine diagram is shown in Figure 5.

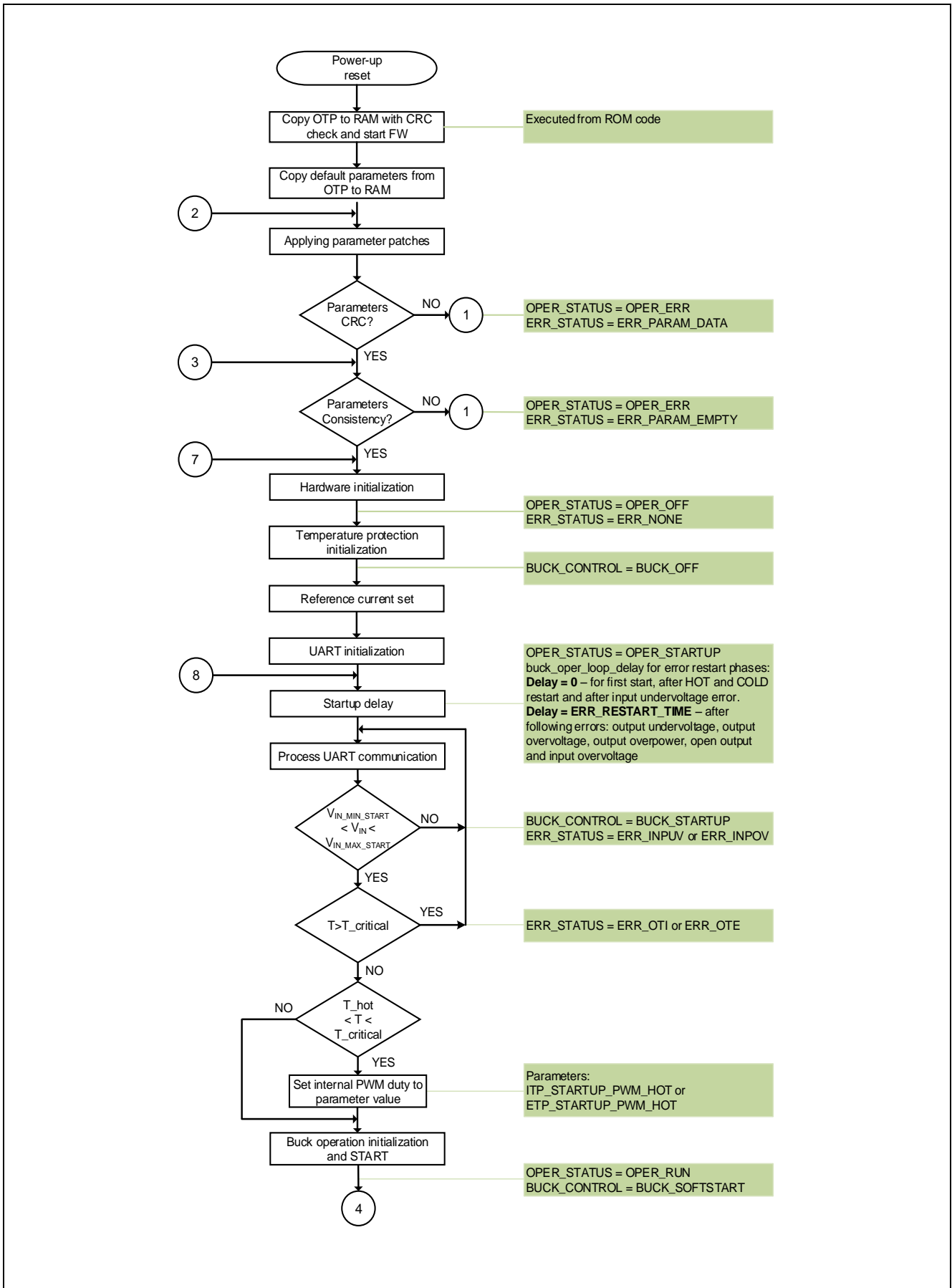

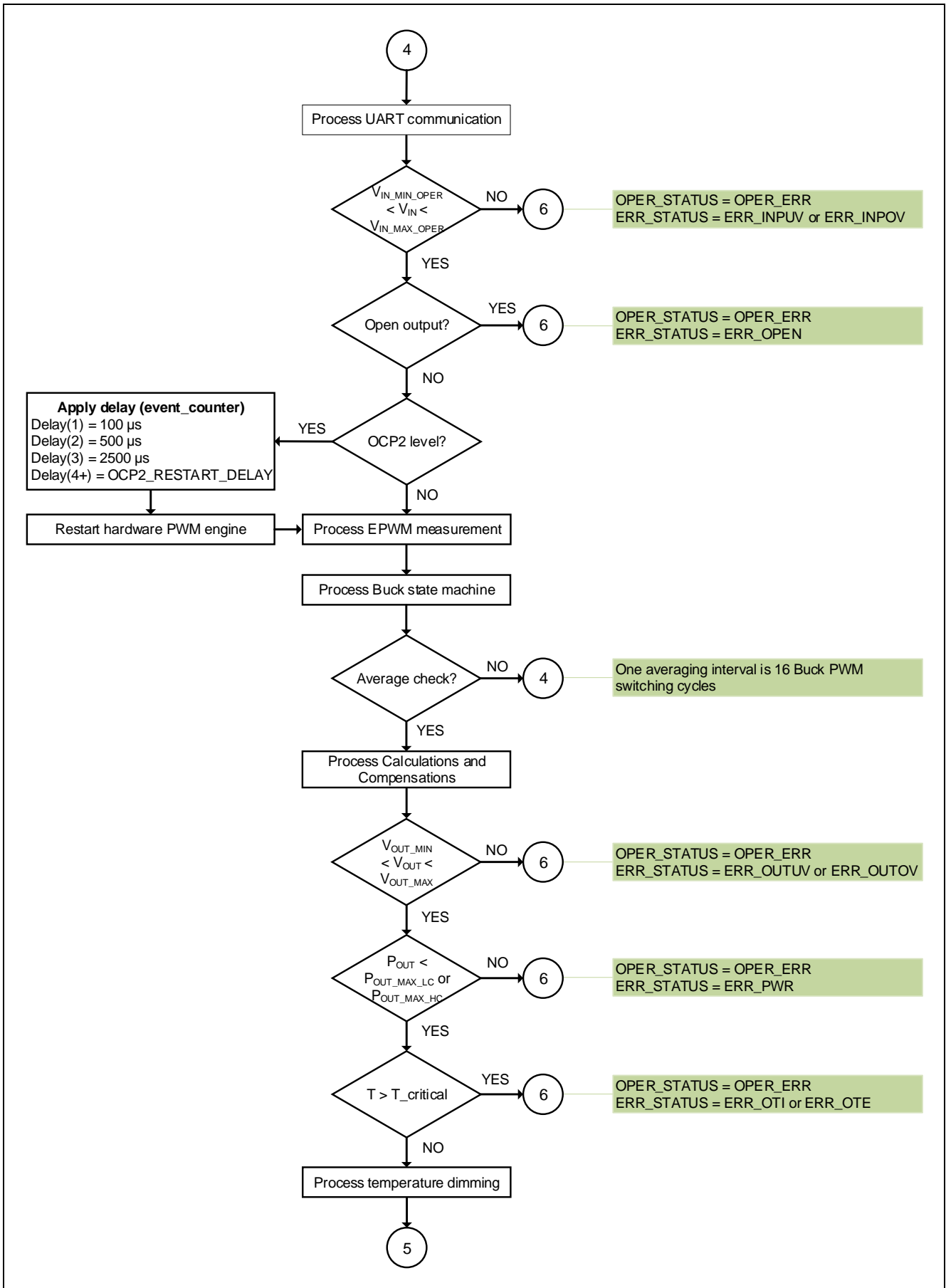

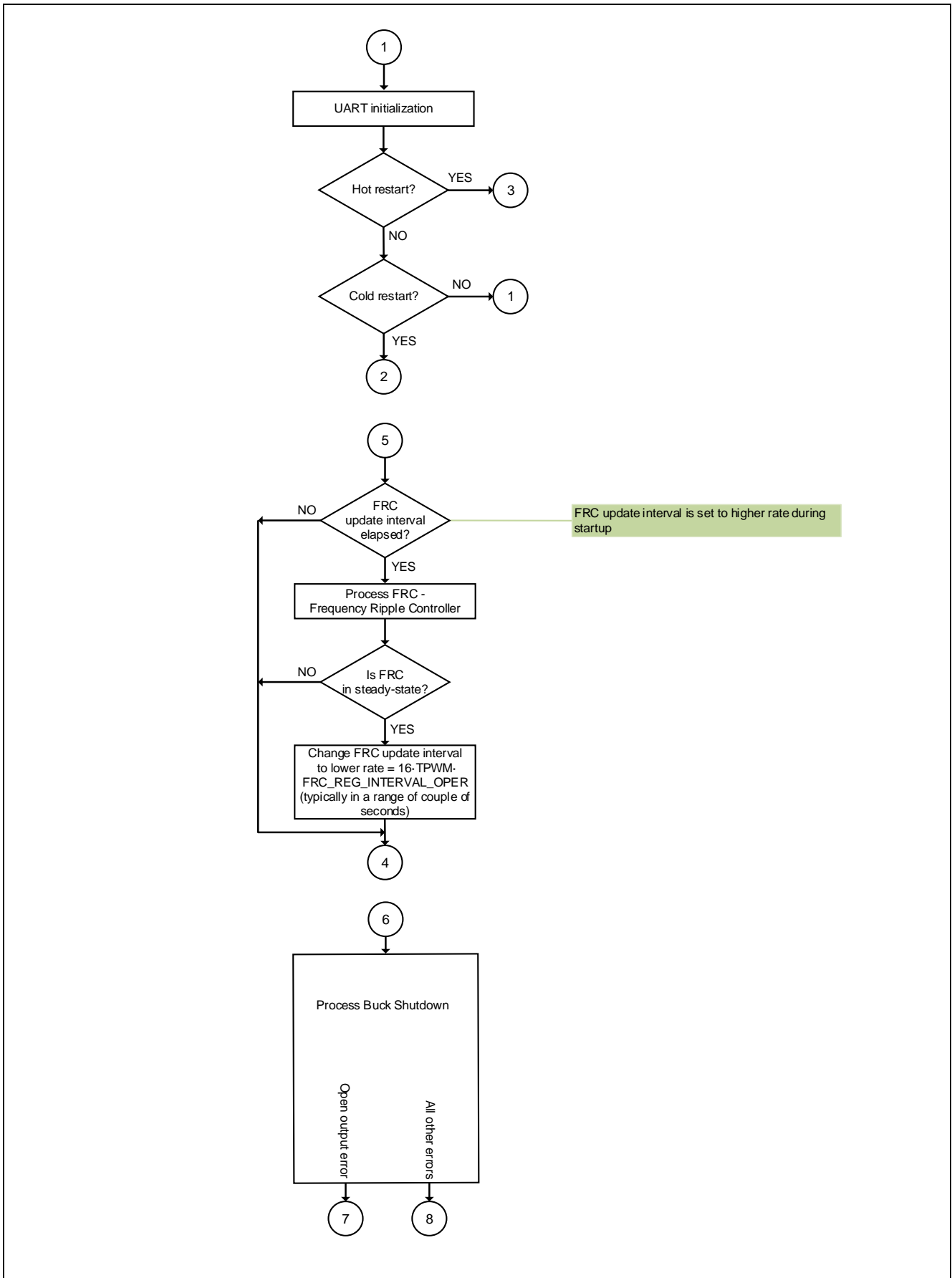

Figure 4. Device Operating Flowchart

Operating statuses are presented in [Table 3-1](#) below.

Table 3-1. Device Operating Statuses

Status	Value	Description
OPER_STATUS	OPER_OFF	0000 _H Off - initial buck state
	OPER_STARTUP	0001 _H Startup - Vin & temperature checking
	OPER_RUN	0002 _H Run
	OPER_ERR	0004 _H Stopped by error
	OPER_STOP	0008 _H Stopped by UART command
ERR_STATUS	ERR_NONE	0000 _H No errors
	ERR_INPUV	0001 _H Input undervoltage
	ERR_INPOV	0002 _H Input overvoltage
	ERR_OUTUV	0004 _H Output undervoltage
	ERR_OUTOV	0008 _H Output overvoltage
	ERR_PWR	0010 _H Output overpower
	ERR_OPEN	0020 _H Output open
	ERR_OCP	0040 _H OCP2 level detection
	ERR_OTI	0080 _H Overtemperature internal sensor
	ERR_OTE	0100 _H Overtemperature external sensor
	ERR_PARAM_EMPTY	0400 _H Default parameter block empty
	ERR_PARAM_DATA	0800 _H Default parameter block checksum error
ERR_MODE	ERR_MODE_LATCH	Error handling latch
	ERR_MODE_RESTART	Error handling auto restart
	ERR_MODE_OFF	Error handling is off
	ERR_MODE_NOP	Error handling does not affect auto restart counter
BUCK_STATUS ¹⁾	BUCK_OFF	Buck is off
	BUCK_STARTUP	Buck is in start-up phase (initialized, waiting for start-up condition, i.e. voltage and temperature)
	BUCK_SOFTSTART	Buck is in soft-start phase (implements increasing current slope until reaching reference current)
	BUCK_SHUTDOWN	Buck is in shutdown phase (implements current decreasing slope)
	BUCK_EXE_OFF	Buck is executing off, buck operation stopped
	BUCK_ERRC	Buck in error state (generate small error current)
	BUCK_ON ²⁾	<p>Buck is on (normal operation, default state of operation)</p> <p>During normal operation, in addition to the aforementioned operations, the following actions will be executed:</p> <ul style="list-style-type: none"> - Open-output processing - Output current PWM dimming processing - V_{CC} / internal temperature measurement and processing - External temperature measurement and processing - OCP1 - peak current processing - OCP2 - peak current processing - EPWM measurement and processing - PI regulator processing - Input over- and undervoltage processing - Output over- and undervoltage processing - Output overpower processing

¹⁾ See buck state machine in [Figure 5](#).

²⁾ The number of averaged buck cycles for steady-state operation, where calculations and protections are handled, is defined by the constant Buck_steady_delay (see [Table 3-14](#)).

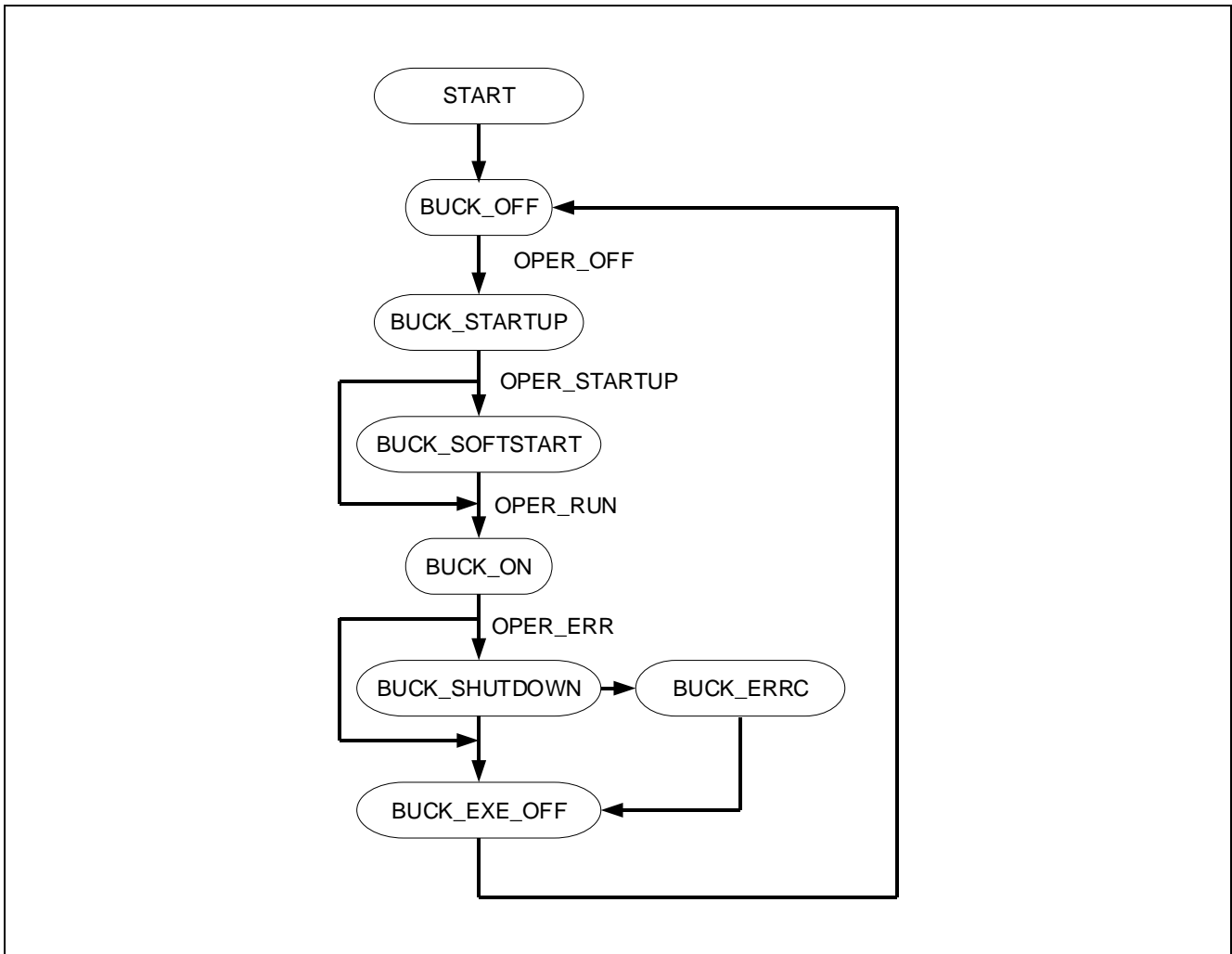

Figure 5. Buck State Machine

3.2 Main Supply (VCC)

The device is powered via the VCC pin. All device supply voltages are internally generated from the V_{CC} voltage.

3.3 Controller Features

[Table 3-2](#) gives an overview of the controller features that are described in the referenced sections.

Table 3-2. Controller Features

Configurable Leading Edge Blanking (LEB) and Sample Time at Pin CS	Section 3.3.1
Configurable Gate Driver Output	Section 3.3.2
Reference Current Setup	Section 3.3.3
Output Current Control and Measuring	Section 3.3.4
Current Startup, Soft-Start and Shutdown Control	Section 3.3.5

3.3.1 Configurable Leading Edge Blanking (LEB) and Sampling Time at Pin CS

A configurable leading edge blanking time t_{CSLEB} is integrated into the current sensing path to provide more accurate output current sensing and regulation. Leading-edge spikes during the PowerMOS switch-on phase, as shown in **Figure 6**, can affect sampled output current values, resulting in imprecise current sensing. The LEB time is used to prevent false overcurrent detection, while the sample time defines the moment of the current sampling for A/D conversion. The time t_{CSLEB} and the sampling time are configured by the constants CS_blanking_time and CS_sample_time respectively (see **Table 3-19**) in order to provide output current sampling at the moment when no spikes are present.

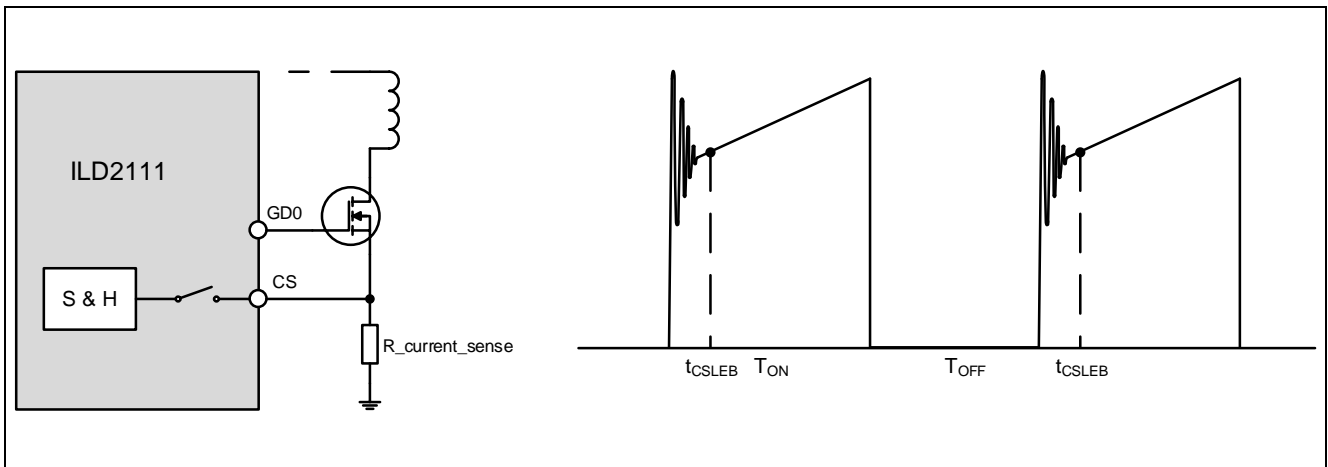

Figure 6. Configurable Leading Edge Blanking Time at Pin CS

3.3.2 Configurable Gate Driver Output

The gate driver output (GDO) can be configured with respect to the final voltage level and gate drive current, which influence the rising voltage slope for switching on the external PowerMOS (see **Figure 7**) and therefore a switch-on time. A compromise should and could be made between switching power losses and electromagnetic radiation by using these parameters (especially gate drive current values). The output gate voltage V_{GDH} and gate current I_{GD} can be programmed by the parameters, providing an adjustable PowerMOS turn-on time. The programmable output gate voltage range is from 4.5 V to 15 V (see **Table 3-8**). V_{GDH} cannot be higher than the power supply voltage V_{CC} , regardless of the programmed value. The programmable gate current range is from 30 mA to 118 mA (see **Table 3-8**). **Figure 7** shows the gate driver output voltage signal. Different rising slopes correspond to different gate driving currents. The slope is proportional to the current.

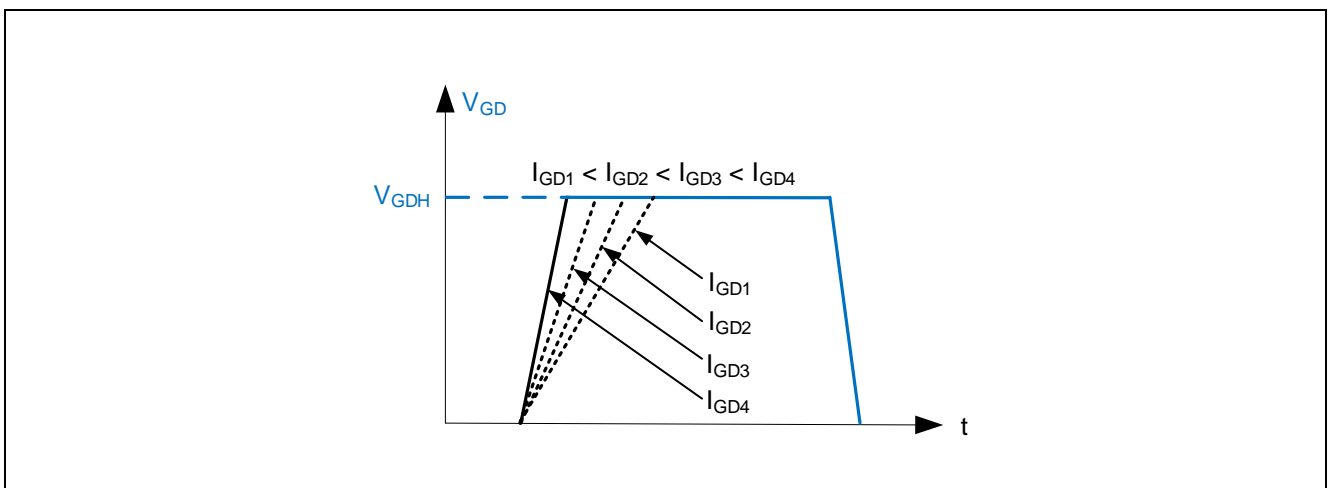

Figure 7. Configurable Gate Driver Output

3.3.3 Reference Current Setup

The reference current value is obtained by measurement using the value of the external resistor R_{iset} connected to the pin 'REF/SC' together with the reference capacitor C_{ref} via the discharge time of the capacitor (see [Figure 8](#) and [Figure 9](#)). Depending on the resistance of R_{iset} , the appropriate reference current, stored in a table of 16 currents (see [Table 3-12](#)), is used as a reference for the output current. The reference current setup procedure (I-set) will always be executed during the startup sequence or during Open output protection recovery – see [Section 3.6.4](#).

When the internal switch SW is turned on for a short period of time defined by the constant $RC_{cap_charge_time}$ (see [Table 3-19](#)) while the digital output is high, the C_{ref} is fully charged to V_{cref} , where this voltage depends on the internal $VDDP$ voltage and voltage divider $R_{ref_sc} - R_{iset}$. R_{ref_sc} is used for decoupling the reference current measurement circuitry and serial UART communication. Care must be taken that the ratio of R_{iset} to R_{ref_sc} is sufficient to have only a low impact on V_{cref} . Otherwise, it has to be included in the time thresholds calculation. When the switch is turned off, the C_{ref} discharges through the external resistor R_{iset} . The discharging time of the capacitor C_{ref} depends on the value of the external resistor. During the discharging interval, the pin voltage is measured by ADC while an internal timer measures the discharging time. When the capacitor voltage drops below the constant threshold level V_{adc_th} (constant V_{ADC_th} , see [Table 3-13](#)), the internal timer value is latched and used to determine the reference current from the predefined I-set table.

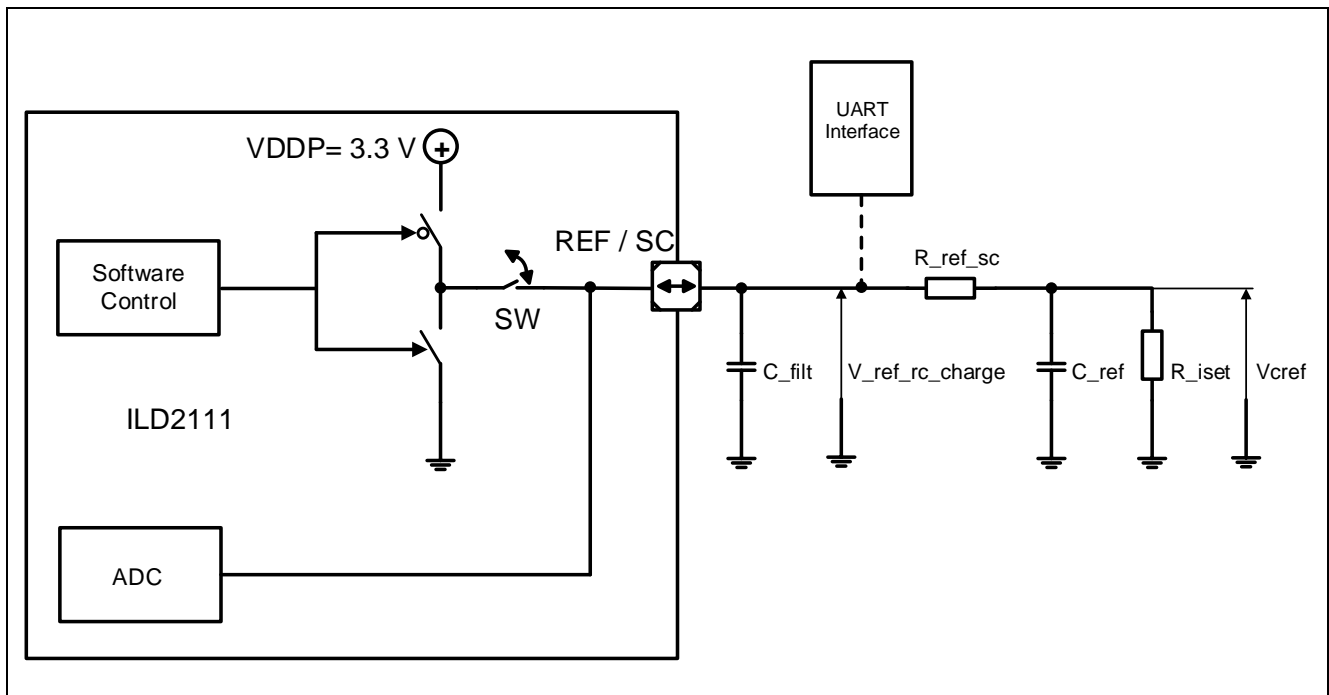

Figure 8. Charging and Discharging of the C_{ref} Capacitance Depending on the Switch State

C_{filt} is a ceramic capacitor used to filter noise, caused by the converter switching operation. Mainly it is used to suppress noise for ADC measurement as well as UART communication.

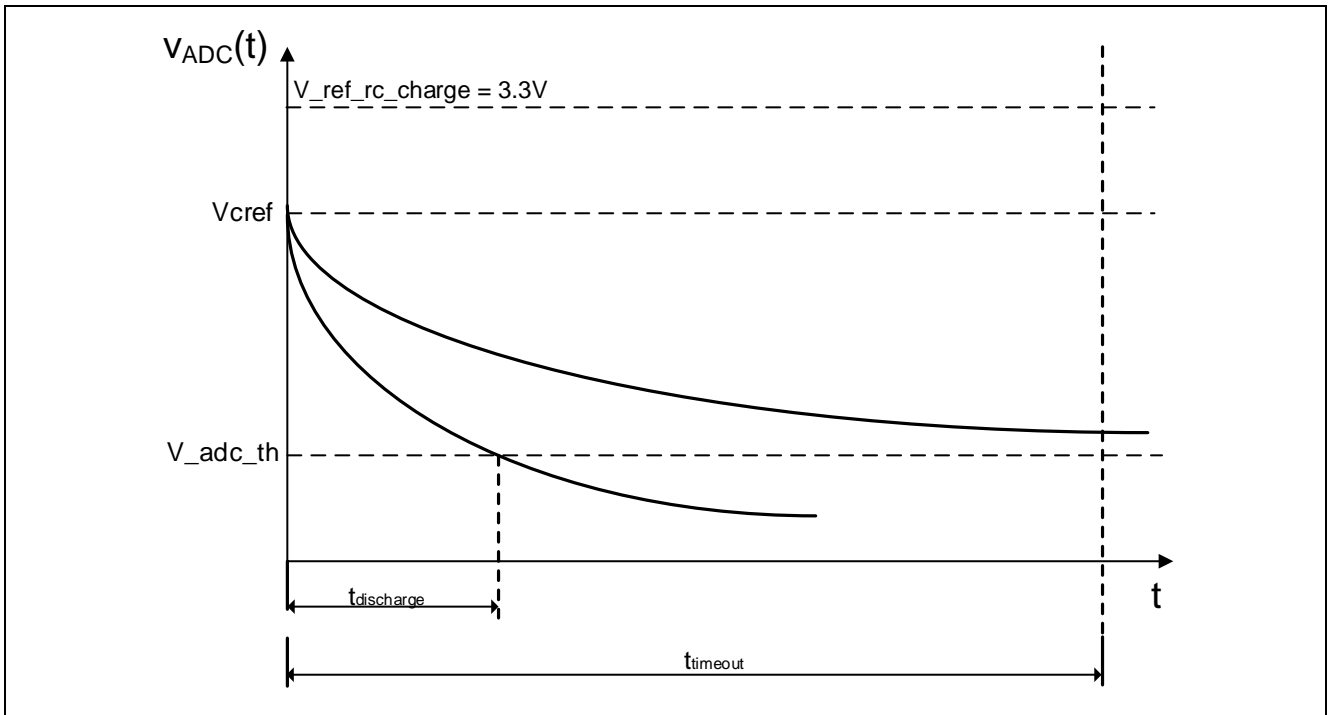

Figure 9. C_ref Discharging Interval Determined by the Reference Resistor Value

The charging voltage V_{cref} is calculated as:

$$V_{cref} = \frac{R_{iset}}{R_{iset} + R_{ref_sc}} \cdot V_{ref_rc_charge}. \quad (1)$$

The equation for V_{adc_th} is:

$$V_{adc_th} = V_{cref} \cdot e^{-\frac{t_{discharge}}{R_{iset} \cdot C_{ref}}}. \quad (2)$$

Therefore:

$$t_{discharge} = R_{iset} \cdot C_{ref} \cdot \ln \frac{V_{cref}}{V_{adc_th}}. \quad (3)$$

If a lower voltage threshold is not reached after the predefined time-out period $t_{timeout}$ (constant $RC_{measurement_timeout}$, see [Table 3-19](#)), the reference current determination process ends and the last value from the current table is taken as the reference (Ref_current_16, see [Table 3-12](#)). Component values and their tolerances must provide unique thresholds in order to be detected appropriately (see [Figure 10](#)).

More accurate equations will be obtained if typical component tolerance values are included.

The following are assumed:

- Maximum reference resistance: $R_{iset_max}(n) = R_{iset}(n) + R_{iset_tolerance}^1$
- Minimum reference resistance: $R_{iset_min}(n) = R_{iset}(n) - R_{iset_tolerance}$
- Maximum reference capacitance: $C_{ref_max} = C_{ref} + C_{ref_tolerance}^2$
- Minimum reference capacitance: $C_{ref_min} = C_{ref} - C_{ref_tolerance}$

¹ The reference resistance R_{ref_sc} is used to decouple the UART interface and current set resistance R_{iset} due to multiplexed functionality of the REF/SC pin. In this case, the tolerance of the R_{ref_sc} resistance is not taken into account (its tolerance is ignored).

² Examples of $C_{ref_tolerance}$ are the tolerance of the used capacitor as well as the cable capacitance that connects R_{iset} to the detection circuit.

Therefore, minimum and maximum discharging times are given by:

$$T_{RC}(n)_{min} = R_{iset_min}(n) \cdot C_{ref_min} \cdot \ln \frac{V_{cref_min}(n)}{V_{adc_th}} \quad (4)$$

and

$$T_{RC}(n)_{max} = R_{iset_max}(n) \cdot C_{ref_max} \cdot \ln \frac{V_{cref_max}(n)}{V_{adc_th}}. \quad (5)$$

Where n is the ordinal number of the resistor, while V_{cref_min} and V_{cref_max} are the minimum and maximum voltage values of charged capacitance respectively:

$$V_{cref_min} = \frac{R_{iset_min}}{R_{iset_min} + R_{ref_sc}} \cdot V_{ref_rc_charge} \quad (6)$$

and

$$V_{cref_max} = \frac{R_{iset_max}}{R_{iset_max} + R_{ref_sc}} \cdot V_{ref_rc_charge}. \quad (7)$$

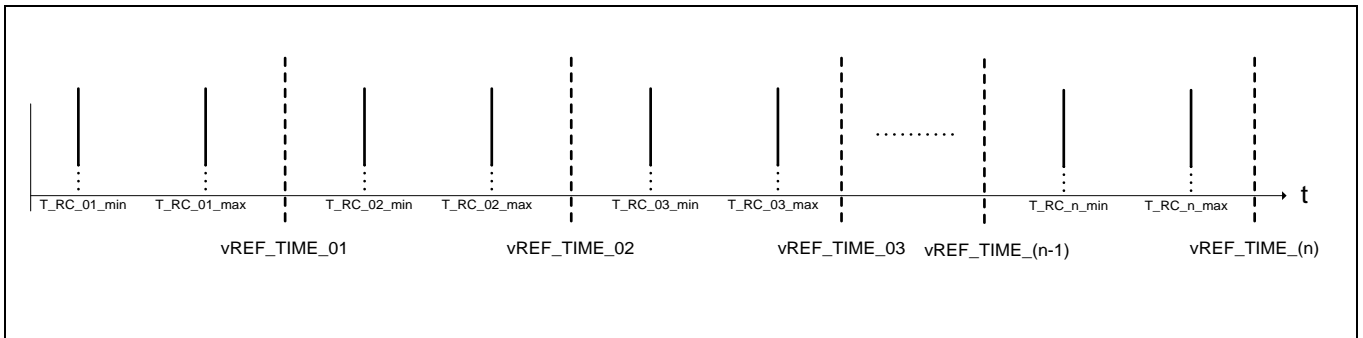

Figure 10. Time Constant vREF_TIME_n Threshold Calculations

As shown above, the discharging time threshold is obtained as follows:

$$vREF_TIME_n = T_{RC_n_max} + \frac{T_{RC_n+1_min} - T_{RC_n_max}}{2}. \quad (8)$$

The last discharge time threshold is given by:

$$vREF_TIME_n = T_{RC_n_max} + \frac{T_{RC_n_max} - T_{RC_n_min}}{2}. \quad (9)$$

The measured discharge time - $t_{discharge}$ is compared with the calculated thresholds, beginning with the smallest, and based on that, it will be determined which reference resistor is detected, hence reference output current. For example, if the measured discharge time is greater than vREF_TIME_01, vREF_TIME_02, vREF_TIME_03 and smaller than vREF_TIME_04, the 4th reference resistor and reference current from the list will be chosen (see [Table 3-3](#)).

The ratio between the maximum and minimum current has to be equal to or less than 4 ($I_{ref_max} / I_{ref_min} \leq 4$) for best current accuracy. For example, if the minimum reference current is 250 mA, the maximum reference current from the range should not exceed 1000 mA.

The components (R_{iset} , C_{ref}) must be carefully selected to avoid overlapping time intervals, because in that case an appropriate threshold could not be calculated to provide unique detection. For example, if the resistance values are too close (including tolerances), discharge time intervals will overlap, and calculated thresholds will be set inside the overlapped area. Therefore it cannot be guaranteed that the same current will be selected across different IC production series and external component tolerances.

Reference current determination only takes place during the initial chip startup and after the load has been disconnected - open output is detected. During normal buck operation, the REF/SC pin can be used as a communication port.

Example

For typical applications, which cover – for example – the outputs ranging from 250 mA to 800 mA (in 50 mA steps), reference resistor values for the specific current values (assuming $C_{ref} = 10$ nF and threshold voltage value of $V_{adc_th} = 0.6075$ V) are given in [Table 3-3](#). Resistors from the series E96 with a variation (tolerance) of 1% are used. The reference pin serial resistor is $R_{ref_sc} = 3.3$ k Ω . The recommended capacitor C_{ref} tolerance should be $\leq 5\%$ ¹. The recommended C_{ref} capacitor type is a zero-drift CoG (NPO).

Table 3-3. Reference Resistor Values Example

Ordinal number	I_{ref_n} [mA]	R_{iset_n} [k Ω]	vREF_TIME_n [μ s]
1	800	2.15	70
2	750	10.00	180
3	700	15.00	280
4	650	21.50	430
5	600	33.20	610
6	550	43.20	780
7	500	53.60	950
8	450	63.40	1110
9	400	71.50	1270
10	350	82.50	1430
11	300	90.90	1580
12	250	100.00	1860

Although, typically, the application uses less than 16 reference currents, all parameters (Ref_current_01- Ref_current_16, see [Table 3-12](#)) must be filled (arranged) in 4 groups, using copies with the same reference current. It is assumed that approximately the same currents have approximately the same parameters. Thereafter, all appropriate reference time thresholds (Reference_time_01 – Reference_time_16) will be automatically allocated to the groups (see [Table 3-19](#)). Each group consists of four consecutive currents and each group is associated with the unique set of FRC parameters. The currents from the same group will have the same minimum and maximum switching frequency limits and minimum and maximum current ripple limits as well (see [Table 3-20](#)).

One possible arrangement is given below in [Table 3-4](#).

¹ For different component tolerances, different discharge times will be obtained by equations. The resistor values in [Table 3-3](#) are given as examples. The number of different reference resistor values must match the number of different reference currents. For different applications (different output currents and output power), different values of the external resistors can be taken.

Table 3-4. Reference Current Arrangement

Group number	Reference Currents
1.	800 mA, 750 mA, 700 mA
2.	650 mA, 600 mA, 550 mA
3.	500 mA, 450 mA, 400 mA
4.	350 mA, 300 mA, 250 mA

3.3.4 Output Current Control and Measuring

The output current is measured at the CS pin by means of an external shunt resistor. The controller, using floating buck topology, operates in a Continuous Conduction Mode (CCM) and is realized as a hysteretic current controller. The average output current is regulated using minimum and maximum currents (I_{MAX} and I_{MIN} , see [Figure 11](#)). Maximum and minimum current values are defined with respect to allowed output current ripple. The maximum current is set as a true analog comparator threshold value using an internal DAC. The minimum current value is regulated by the internal PI regulator controlling T_{OFF} time.

When the MOSFET is turned on, T_{ON} is approximately given as follows (all resistances and voltage drops of used components are neglected):

$$T_{ON} = (I_{MAX} - I_{MIN}) \cdot \frac{L_{EXT}}{V_{IN} - V_{OUT}} = I_{RIPPLE} \cdot \frac{L_{EXT}}{V_{IN} - V_{OUT}} \quad (10)$$

When the MOSFET is turned off, T_{OFF} is approximately given as follows (all resistances and voltage drops of used components are neglected):

$$T_{OFF} = (I_{MAX} - I_{MIN}) \cdot \frac{L_{EXT}}{V_{OUT}} = I_{RIPPLE} \cdot \frac{L_{EXT}}{V_{OUT}} \quad (11)$$

where V_{IN} and V_{OUT} are the input and output voltages respectively and L_{EXT} is the buck inductance. Therefore, the switching frequency of the buck cycle can be rendered as:

$$f_{SW} = \frac{1}{T_{ON} + T_{OFF}} = \frac{1}{I_{RIPPLE} \cdot L_{EXT} \cdot \left(\frac{1}{V_{IN} - V_{OUT}} + \frac{1}{V_{OUT}} \right)} \quad (12)$$

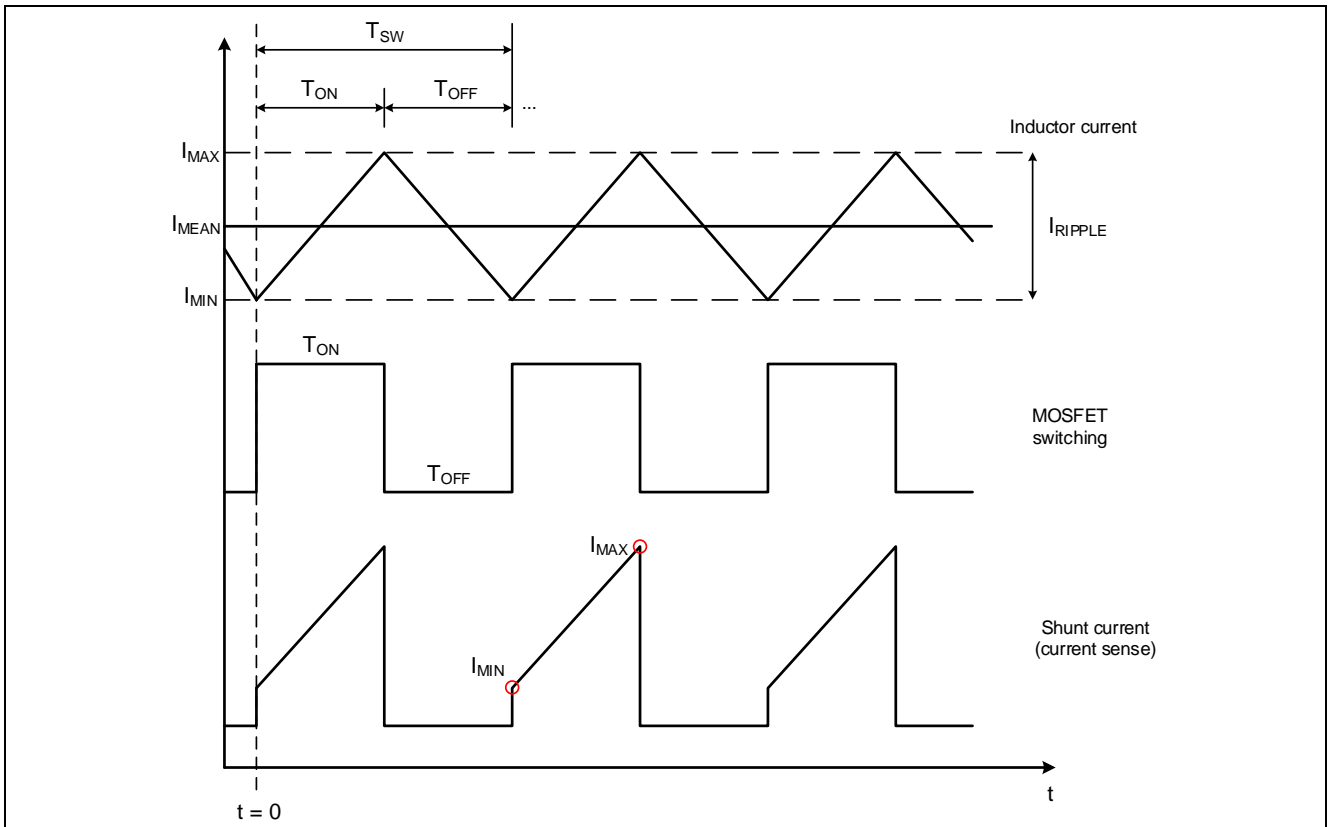
Figure 11. Sampled Current

When the current reaches its maximum value (I_{MAX}), the MOSFET is turned off for a duration of T_{OFF} , which is defined by the output of the PI regulator. After this interval elapses, the MOSFET is turned on again, the minimum current (I_{MIN}) is sampled and the mean current for the entire PWM interval is calculated as:

$$I_{MEAN} = \frac{I_{MAX} + I_{MIN}}{2} \quad (13)$$

The minimum current samples are averaged and averaging happens every 16 switching cycles. This average value is then compared to a reference providing an error signal for the PI regulator, as shown in [Figure 12](#). Based on that error, the PI regulator calculates the new T_{OFF} time resulting in output current regulation, hence closing the regulation loop.

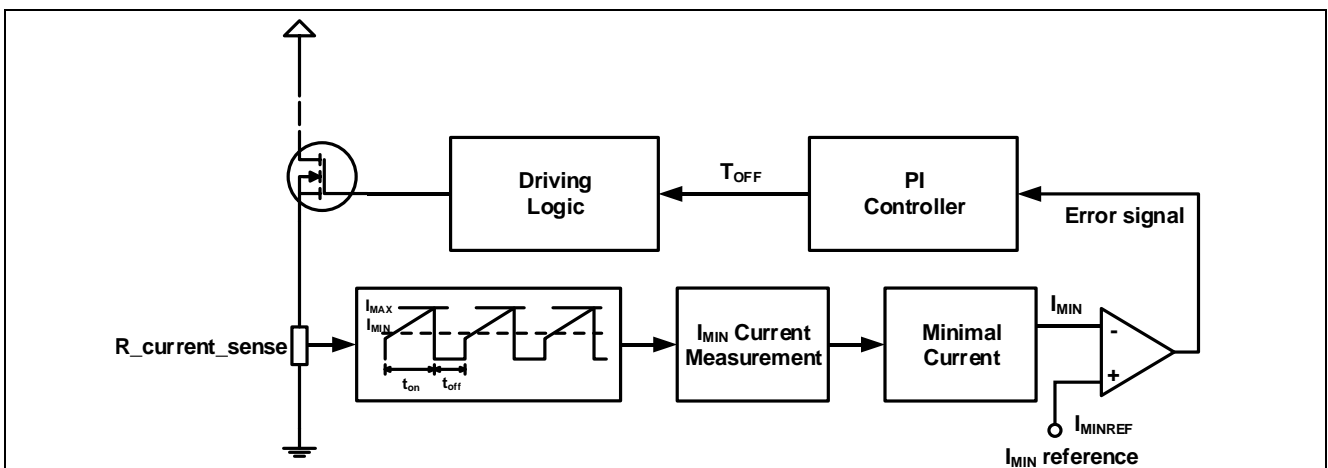
Figure 12. Hysteretic Current Regulator

PI regulator parameters can be adjusted for faster transient response (dynamic behavior) during startup and more stable output current during normal steady-state operation. These constants (PI_shift_softstart_lc, PI_gain_shift_softstart_hc, PI_gain_shift_lc and PI_gain_shift_hc, see [Table 3-17](#)) are divided into two groups depending on the current range (constant Ref_current_HCTH, see [Table 3-14](#)) and operating conditions (startup or normal). Constants for low currents (low range - LC) typically have larger values than high current parameter values (high range - HC) because, for lower currents, the error signal has to be multiplied by a larger number (Gain) to obtain appropriate behavior regarding response and stability of the output current.

3.3.5 Current Startup, Soft-Start and Shutdown Control

Current soft-start and shutdown control is implemented in order to keep the input voltage V_{IN} and supply voltage V_{CC} , which come from the primary stage (usually a flyback converter with a transformer auxiliary winding for VCC voltage), within the operating range and stable.

During the soft-start time, the output (mean) current increases slowly with programmable parameters. The startup current is defined by the constant Softstart_start_curr (see [Table 3-16](#)). Current and time steps are defined by the constant Softstart_curr_step (see [Table 3-16](#)) and parameter Softstart_time_step respectively (see [Table 3-11](#), green line in [Figure 13](#)). The time step can be set as a number of system ticks (the default value is 100 μ s). If any of the step ($I_{CSUS} = \text{Softstart_curr_step}$ or $t_{CSUS} = \text{Softstart_time_step}$) values is zero, the buck converter will start with a 100% current, and without soft-start.

During soft shutdown time, the output current decreases slowly with programmable current and time steps (constant Softshutdown_curr_step - [Table 3-16](#) and parameter Softshutdown_time_step - [Table 3-11](#), see red line in [Figure 13](#)). Hence, the input voltage V_{IN} and supply voltage V_{CC} remain in the operating range and the device will work correctly.

If the soft shutdown is not enough to provide an appropriate operating range (for V_{IN} and V_{CC}), some minimum current (ERROR CURRENT - I_{ERROR}) defined by the parameters Err_refcurrent_max and Err_refcurrent_min (see [Table 3-9](#) and [Figure 13](#)) will be generated for a defined time period (error time). When this time interval has elapsed (Error time timeout - constant Err_current_time, see [Table 3-14](#)), the output current is zero. If the current soft shutdown is not needed, it is necessary to set either the parameter to zero ($I_{CSDS} = \text{Softshutdown_curr_step}$ or $t_{CSDS} = \text{Softshutdown_time_step}$).

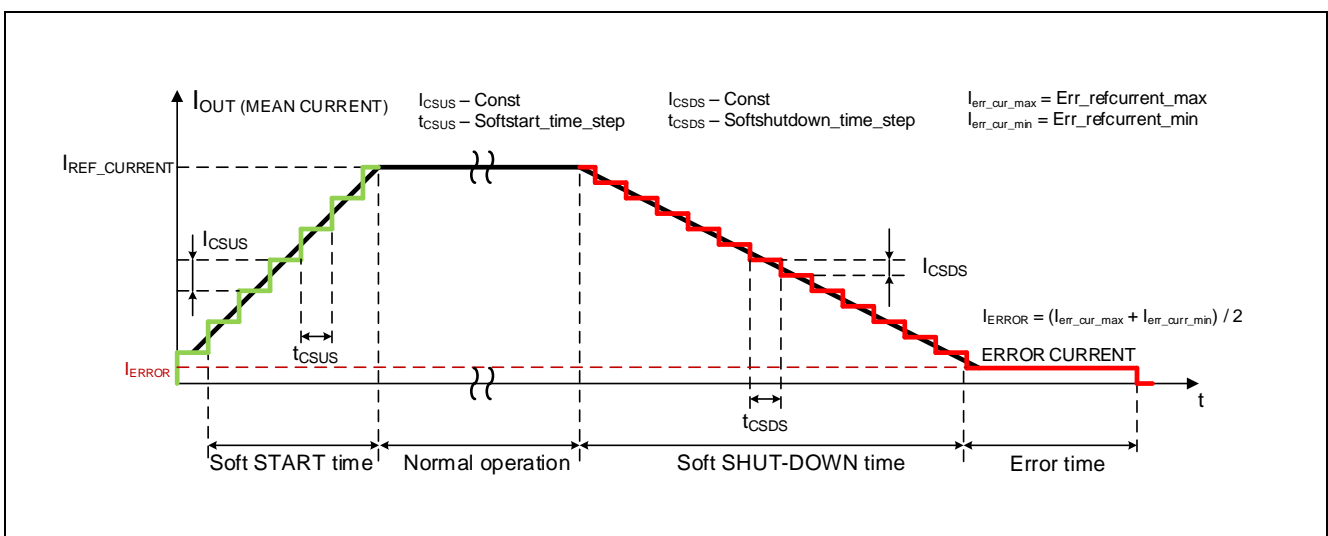

Figure 13. Soft-Start and Soft Shutdown Definitions

3.4 Current Ripple vs. Switching Frequency Control Scheme

The switching frequency and output current ripple must be handled in such a way as to ensure that the efficiency is as high as possible and that the ripple is in a proper range with sufficient margin to the specified maximum. Two options for implementing a suitable system are described below.

3.4.1 Fixed Current Ripple

For a fixed current ripple, it is necessary to choose an appropriate value for the current ripple (parameter Curr_ripple_perc, see [Table 3-12](#)) so the switching frequency does not exceed the maximum allowed frequency around the output voltage $V_{OUT} = V_{IN}/2$. The maximum switching frequency should not exceed 250 kHz. Examples for three different current values are shown in [Figure 14](#).

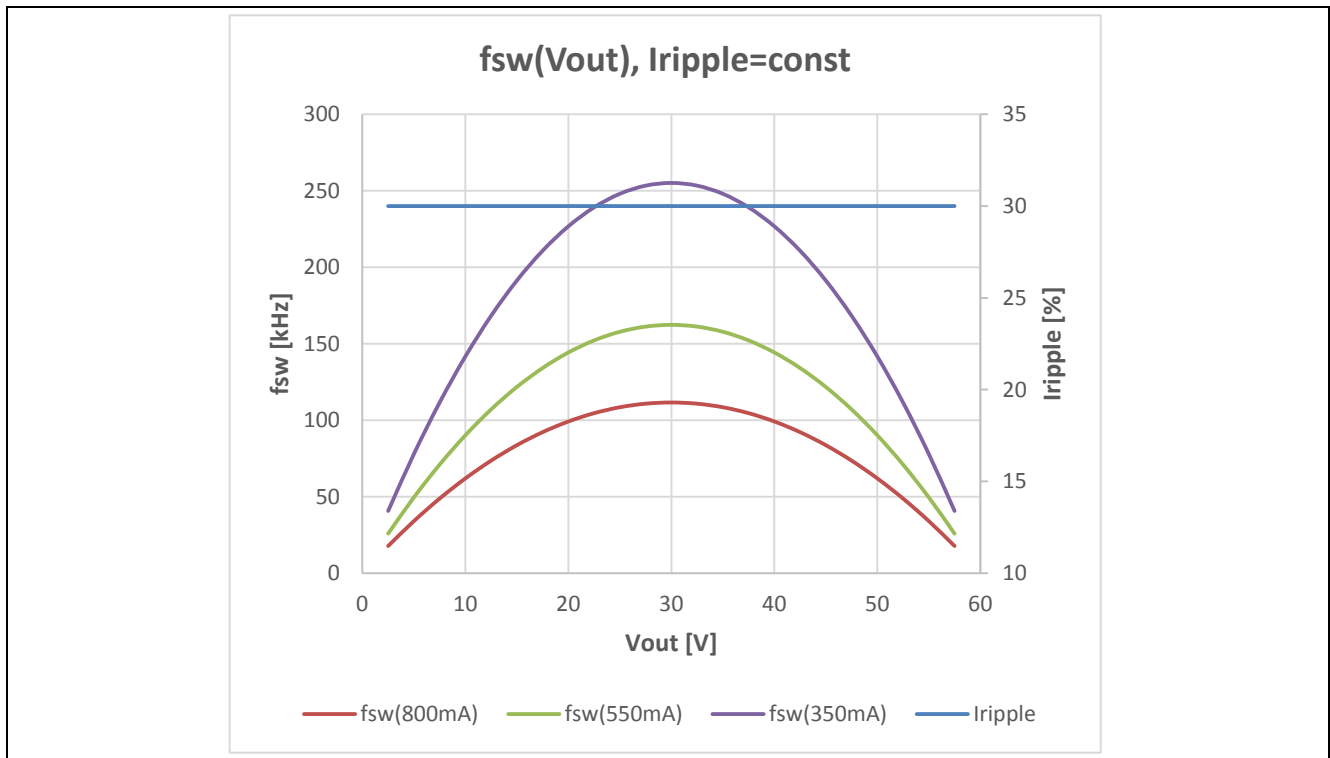

Figure 14. Switching Frequency vs. Output Voltage for Constant Output Current Ripple Iripple = 30%

3.4.2 Frequency and Ripple Control

The ILD2111 supports a powerful Frequency Ripple Controller (FRC) because the switching frequency of the Buck converter is not constant due to different loads (different number of LEDs leading to different output voltages). The main idea is to stabilize the operating point within configurable limits (operating area – green field, see [Figure 15](#)). During startup and normal operation, the frequency-ripple control update interval is defined by the constants `FRC_reg_interval_start` and `FRC_reg_interval_oper` (see [Table 3-20](#)). The number of FRC passes, before being considered steady, is defined by the constant `FRC_pass_oper_th` (see [Table 3-20](#)).

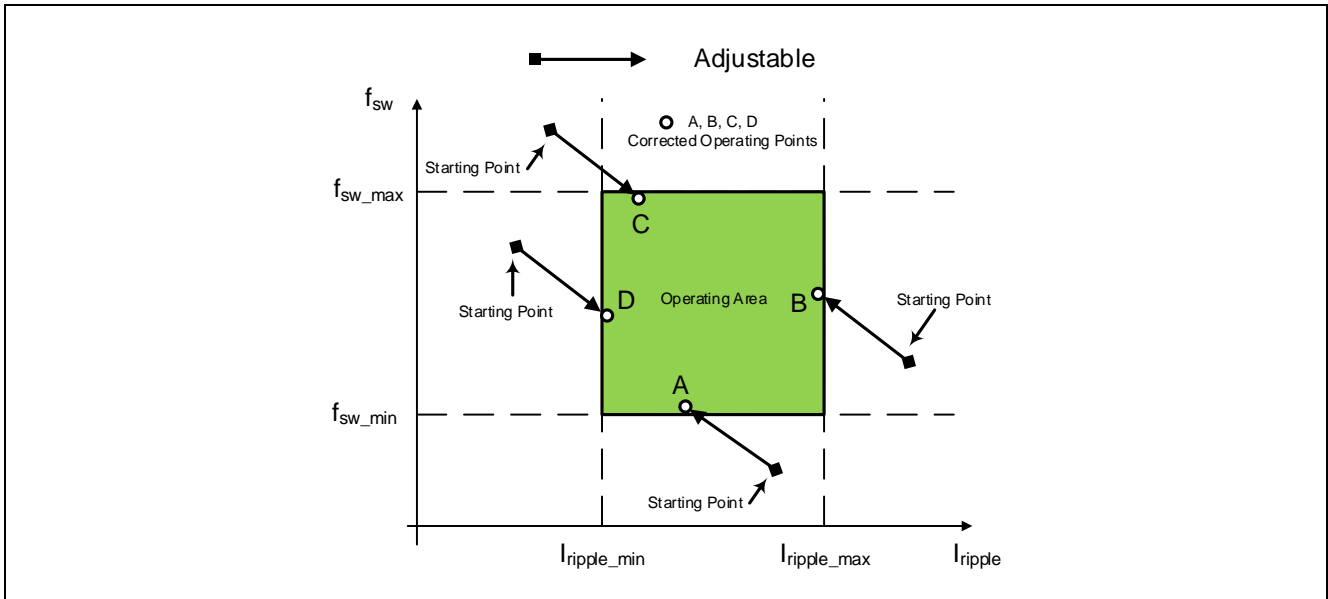

Figure 15. FRC Operating Area

All reference current values will be arranged in four groups (see [Table 3-12](#)) where currents from the same group have the same switching frequency and current ripple limits, as explained in [Section 3.3.3](#).

For each group, there are predefined (available) parameters and constants (see [Table 3-12](#) and [Table 3-20](#)):

- 1) `Curr_ripple_perc` – Initial (starting) current ripple (in percentage form).
- 2) `Curr_ripple_min_(group)` – Minimum allowed ripple value (minimum absolute output current ripple value, I_{ripple_min} in mA, not in percentage form).
- 3) `Curr_ripple_max_(group)` – Maximum allowed ripple value (maximum absolute output current ripple value, I_{ripple_max} in mA, not in percentage form).
- 4) `FRC_freq_min_limit_(group)` – Maximum allowed T_{PWM} (defining the minimum switching frequency allowed, f_{sw_min}).
- 5) `FRC_freq_max_limit_(group)` – Minimum allowed T_{PWM} (defining the maximum switching frequency allowed, f_{sw_max}).

An example is provided below for better understanding. The following parameters apply in this example for $I_{OUT} = 350 \text{ mA}$:

1. $I_{ripple_init} = 30\%$ (or 105 mA) – Initial starting current ripple.
2. $I_{ripple_min} = 25\%$ (or 87.5 mA) – Minimum allowed current ripple.
3. $I_{ripple_max} = 50\%$ (or 175 mA) – Maximum allowed current ripple.
4. $f_{sw_min} = 100 \text{ kHz}$ (or $T_{PWM_max} = 1/f_{sw_min} = 10 \mu\text{s}$) – Minimum allowed switching frequency.
5. $f_{sw_max} = 150 \text{ kHz}$ (or $T_{PWM_min} = 1/f_{sw_max} = 6.67 \mu\text{s}$) – Maximum allowed switching frequency.

The Frequency Ripple Control algorithm works as following:

The system begins to operate with the defined ripple, which is given as a percentage of the average current (e.g. $I_{ripple_init} = 30\% I_{OUT}$). This value is used to calculate the maximum (adding the half-ripple value to the reference current value) and minimum (subtracting the half-ripple value to the reference current value) hysteretic currents. There are several possible cases depending on the output voltage:

- 1) If the achieved operating frequency is within allowed borders (defined by f_{sw_min} and f_{sw_max}), and the starting value of the ripple is within allowed absolute ripple borders (defined by I_{ripple_min} and I_{ripple_max}), no correction will be performed (e.g. $V_{out} = 10 \text{ V}$ – orange curve, operating point B is in the operating area, $B=B'$, see [Figure 16](#)).
- 2) If the achieved operating frequency is above the maximum allowed switching frequency f_{sw_max} (e.g. $V_{out} = 15 \text{ V}$ – grey curve, point C; $V_{out} = 20 \text{ V}$ – yellow curve, point D), the firmware will start to slowly increase the ripple in order to lower the operating frequency (the slope of this increasing ripple depends on the buck inductance L_{EXT} , see equation (12) on page 17). It will continue increasing the ripple until the frequency falls below the high threshold f_{sw_max} (corrected points C' and D', see [Figure 16](#)).
- 3) If the achieved operating frequency is above the maximum allowed switching frequency f_{sw_max} (e.g. $V_{out} = 25 \text{ V}$ – dark blue curve, point E; $V_{out} = 30 \text{ V}$ – green curve, point F), the firmware will start to slowly increase the ripple in order to lower the operating frequency (the slope of this increasing ripple depends on the buck inductance L_{EXT} , see equation (12) on page 17). It will continue increasing the ripple until it hits its maximum allowed value I_{ripple_max} . The switching frequency will be determined by I_{ripple_max} and could be outside the predefined borders (corrected points E' and F', see [Figure 17](#)).
- 4) If the achieved operating frequency is below the minimum allowed switching frequency f_{sw_min} (e.g. $V_{out} = 5 \text{ V}$ – blue curve, point A), the firmware will start to slowly decrease the ripple in order to raise the operating frequency (the slope of this decreasing ripple depends on the buck inductance L_{EXT} , see equation (12) on page 17). It will continue decreasing the ripple until the frequency reaches the low threshold value defined by the parameter f_{sw_min} , or if the ripple hits the minimum allowed value defined by the parameter I_{ripple_min} . In this case, the switching frequency could be outside the predefined borders (corrected point A', see [Figure 17](#)).

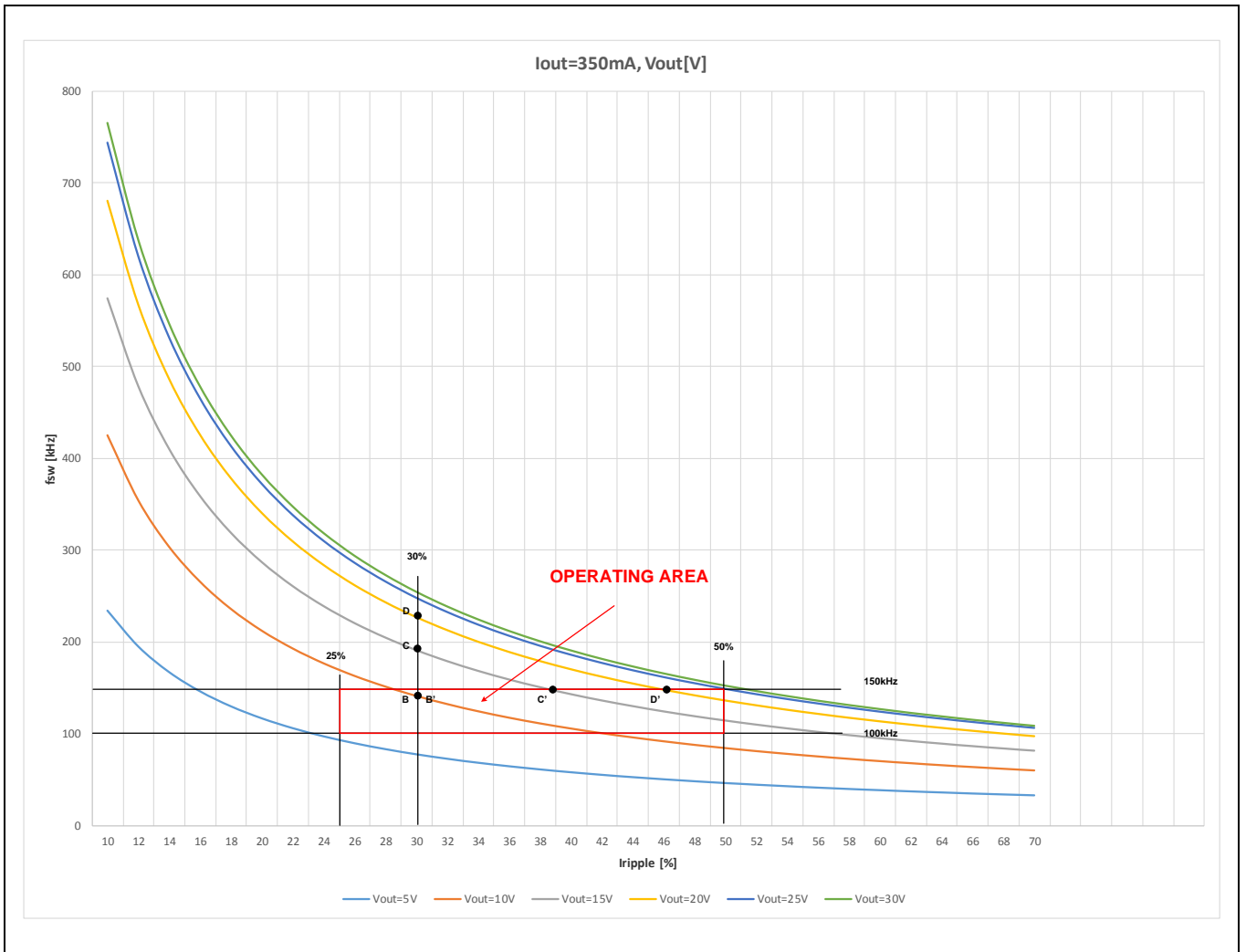

Figure 16. FRC Algorithm Example – Operating Point successfully put into Operating Area

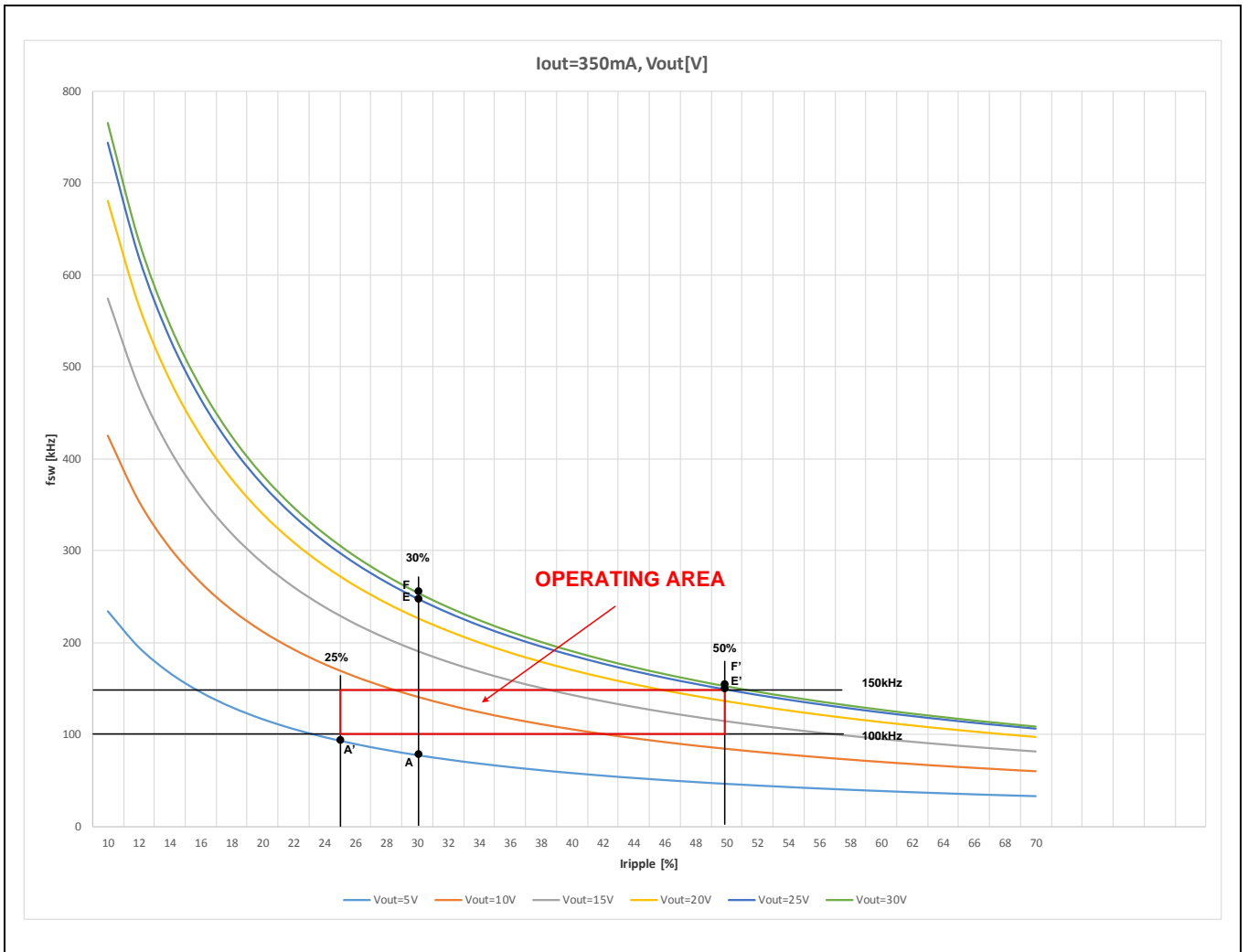

Figure 17. FRC Algorithm Example – Operating Point is outside the Predefined Borders

Functional Description

An example of a frequency ripple control scheme is shown below in **Figure 18**, **Figure 19** and **Figure 20**. Resistances and voltage drops of used components (V_D – forward voltage of the freewheeling diode, R_L – inductor resistance, $R_{ON} = R_{DS}$ – channel resistance when the MOSFET is ON, R_{CS} – shunt resistance connected to the CS pin, $V_{OUT} = N \cdot V_{LED} + N \cdot R_{LED} \cdot I_{OUT}$ – output voltage (LED lighting load), N – number of LEDs, V_{LED} – LED forward voltage, R_{LED} – LED forward resistance) are included in calculations.

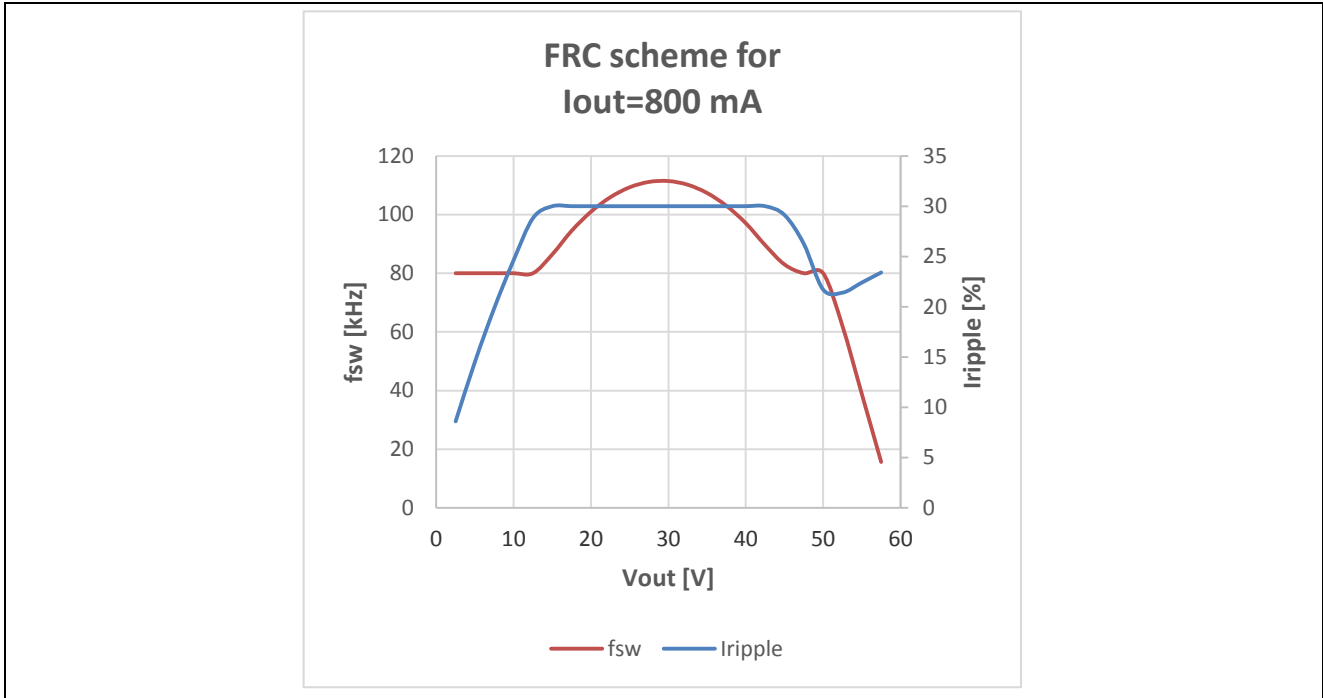

Figure 18. 800 mA FRC Scheme

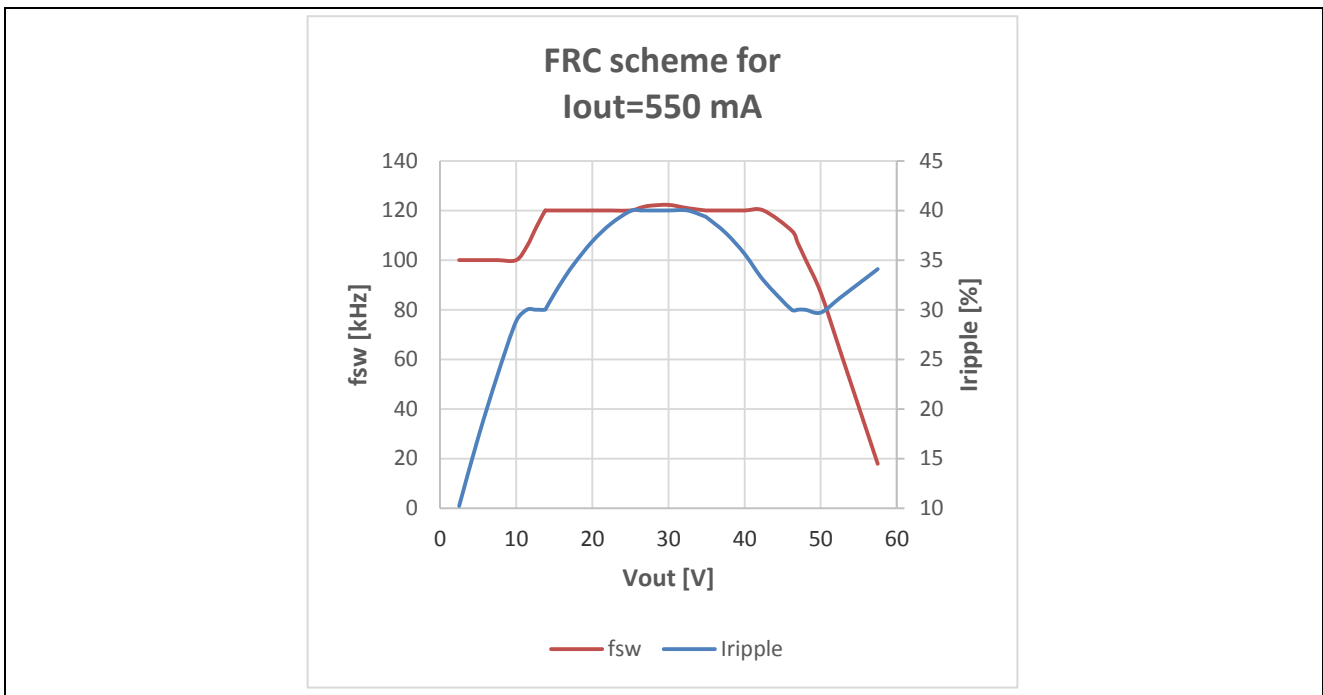

Figure 19. 550 mA FRC Scheme

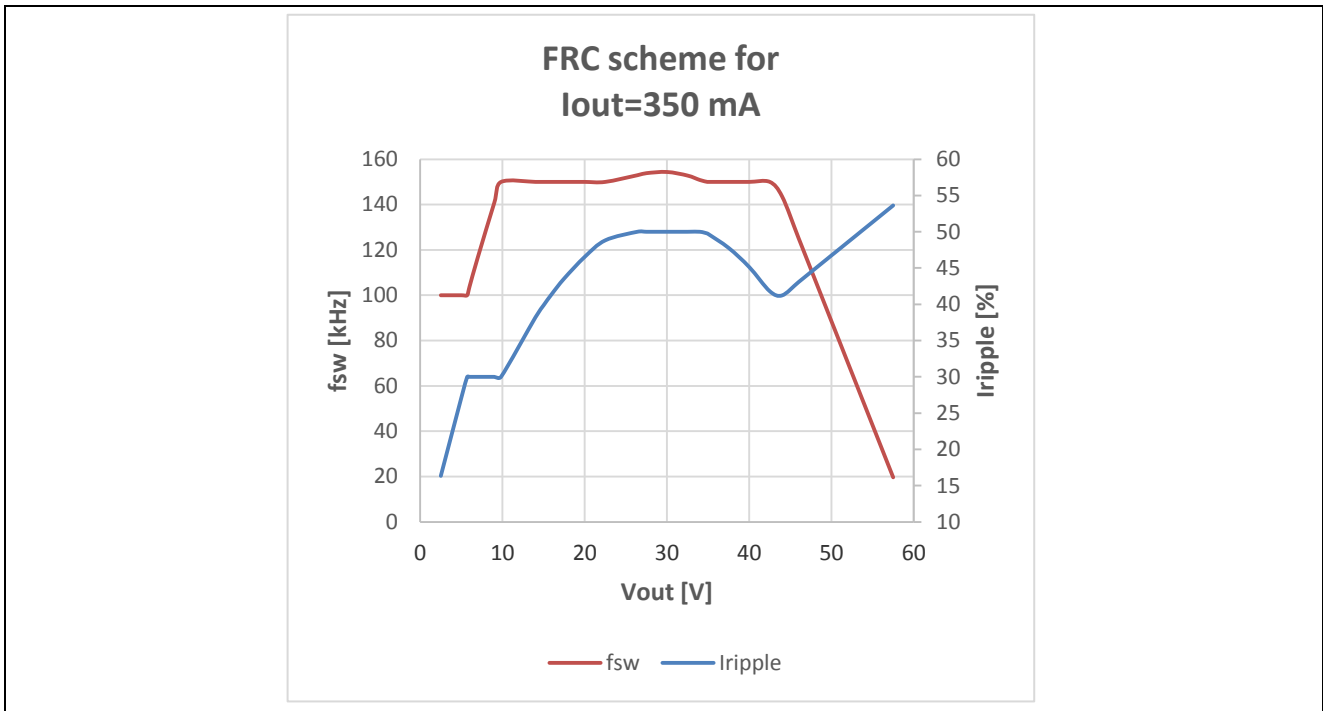

Figure 20. 350 mA FRC Scheme

Frequency Ripple Controller behavior depends on the output voltage load as mentioned before. As can be seen in previous figures, the FRC regulates the switching frequency and current ripple for this dedicated example as follows:

- 1st area – $V_{out} < 10$ V: The system will be started with the minimum constant switching frequency and the ripple will increase accordingly.
- 2nd area – 10 V $< V_{out} < 15$ V approximately: The system will be started with a selectable initial current ripple (30% of I_{out}). The switching frequency will be changed accordingly (not valid for 800 mA).
- 3rd area – $15 < V_{out} < 25$ V approximately: The system will be started with the maximum frequency value; it will be kept constant at a predefined value and the current ripple will increase accordingly (not valid for 800 mA).
- 4th area – $V_{out} \approx V_{IN}/2$: The system is started with the maximum predefined current ripple, but the frequency cannot be kept within predefined borders, which means that the frequency will be determined by the T_{OFF} and I_{ripple} values and external hardware components.
- 5th area – $V_{out} > 45$ V (near V_{IN}) approximately: T_{OFF_min} criteria have the highest priority¹, so the frequency and ripple will have the values determined by the external hardware components (not by FRC) and can be outside the defined limits.

¹ If the high voltage load is applied at the output (large number of LEDs, the output voltage is near the input voltage), the operating frequency will be low and if it falls below f_{sw_min} , the frequency-ripple controller will start to correct it by decreasing the ripple value, as described above. On the other hand, due to the high output voltage, T_{OFF} is quite short (see equation (11) on page 17). It is very important that the turn-off time must be longer than the predefined T_{OFF_min} time (constant T_{off_min} , see Table 3-19), because during that time all calculations must be performed before starting a new cycle. At that point, the frequency-ripple controller starts to increase the ripple again in order to meet T_{OFF_min} criteria. The final outcome is that the current ripple and switching frequency could stay outside the predefined limits (above I_{ripple_max} and below f_{sw_min} respectively) – point G' in Figure 21. If T_{OFF} falls below the minimum allowed value (low ripple means short T_{OFF} time for constant output voltage), the regulator cannot maintain the average current any longer, therefore influencing accuracy. If parameters are configured properly, any of above mentioned actions lead to stable operating conditions for the given current/load situation. However, there is drift in the operating frequency produced by the input voltage ripple that has to be taken into account when deciding on parameter values. The frequency ripple controller will always try to put the operating point into the operating area, but its final position will depend on the other criteria that affect its position.

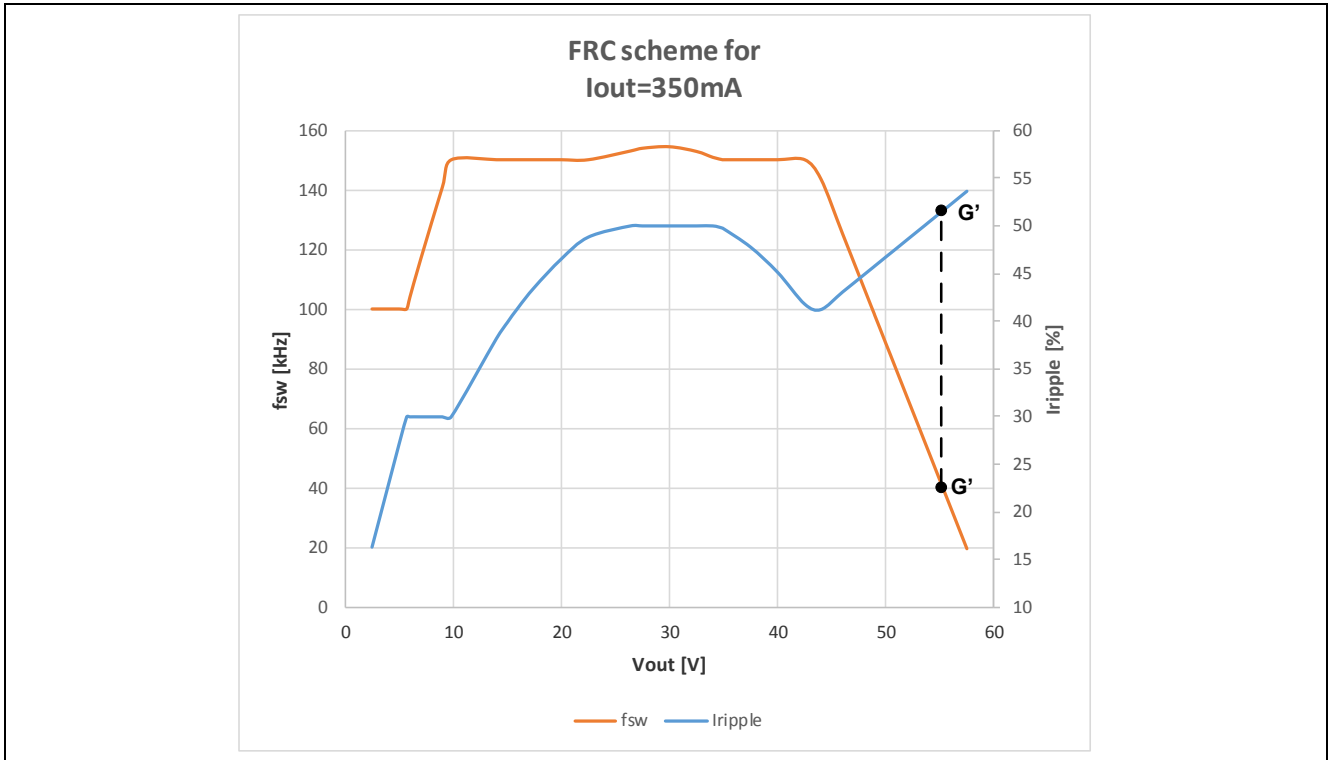

Figure 21. Operating Point determined by Toff_min criteria

3.5 Input Voltage Measurement and Calibration

There are some indirect measurements, like the output voltage V_{OUT} and output power P_{OUT} , that take input voltage measurement as an input. Therefore the accuracy of those measurements depends on the input voltage V_{IN} accuracy, and typically is lower due to the accuracies of other variables. Therefore it is important that the input voltage is accurately measured. The input voltage is sensed at the VIN pin. A filter capacitor C_{VIN} (typically 100 nF) is used for voltage (at the pin VIN) filtering of conductive and electromagnetic interference caused by the converter switching operation. The measurement circuit is shown in [Figure 22](#) below.

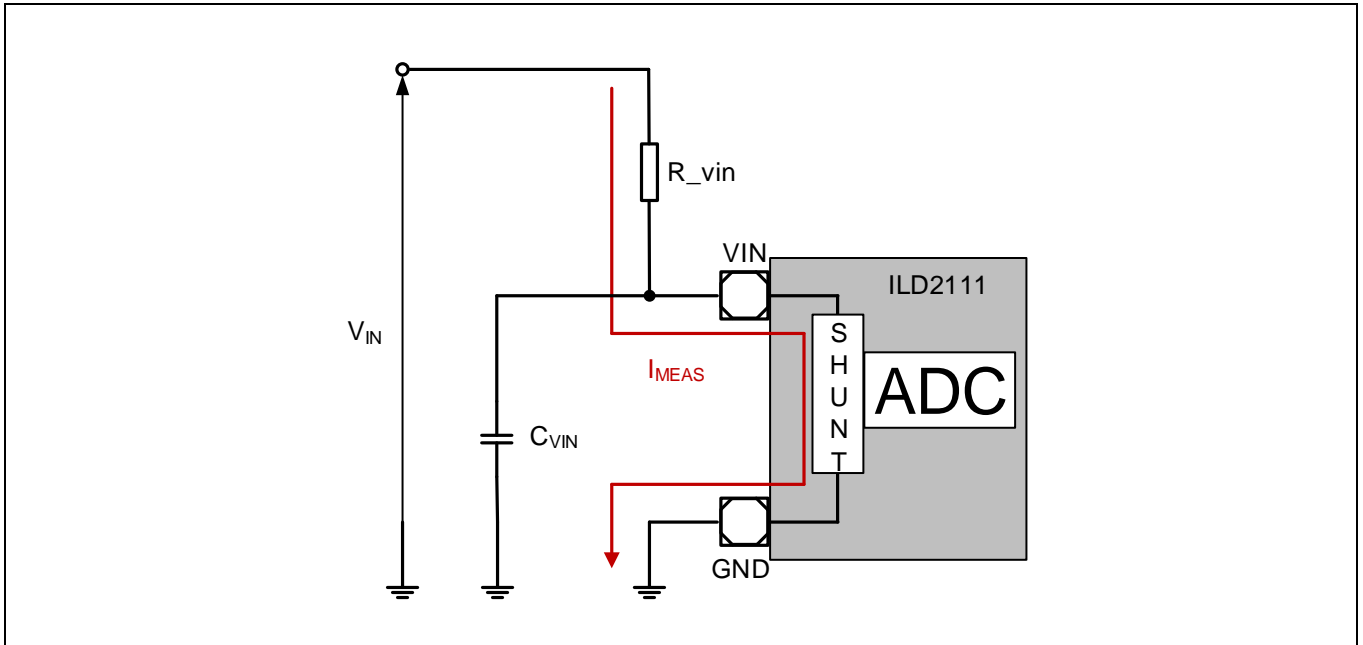

Figure 22. Input Voltage Measurement Schematic

Two measurement ranges related to the VIN pin are implemented. They are called current ranges because calibration is based on the current flowing into the VIN pin. The two ranges use a different value of the internal shunt resistor, where ADC measures the voltage drop. The reason for calibration is to make results independent of R_{SHUNT} production tolerance by including the measured value of R_{SHUNT} as part of internal chip calibration data during chip production.

Nominal shunt values for an appropriate current range are as follows:

- 1) Current range 00_b => $I_{MEAS} = 209 \mu A$, $R_{SHUNT} = 6690 \Omega$.
- 2) Current range 01_b => $I_{MEAS} = 1.6 \text{ mA}$, $R_{SHUNT} = 1490 \Omega$.

The current range is defined by the parameter Vin_current_range (see [Table 3-8](#)).

Depending on the input voltage range to be measured, for lower power dissipation, the value of the external resistor R_{vin} and the maximum current measurement range must be chosen carefully. Especially for high V_{IN} voltage (bus voltage), power dissipation needs to be considered as part of system losses.

For more details, see the examples below.

Examples:

- 1) If the maximum bus voltage is high, e.g. $V_{INMAX} = 500 \text{ V}$, the current measurement range ($209 \mu\text{A}$) should be chosen to minimize power dissipation over R_{vin} . The value of the external resistor R_{vin} is obtained from the equation below ($209 \mu\text{A}$ would ideally be full scale at the ADC; to achieve accurate measurement over the production spread of ILD2111, use a margin factor of 75%).

Therefore,

$$R_{vin} = \frac{V_{INMAX}}{0.75 \cdot I_{209\mu A}} - R_{SHUNT} = 3.18 \text{ M}\Omega. \quad (14)$$

- 2) If the maximum bus voltage is lower, e.g. $V_{INMAX} = 80 \text{ V}$, the current measurement range (1.6 mA) should be chosen.

Therefore,

$$R_{vin} = \frac{V_{INMAX}}{0.75 \cdot I_{1.6mA}} - R_{SHUNT} = 65.2 \text{ k}\Omega. \quad (15)$$

3.6 Protection Features

Table 3-5 gives an overview of the supported protection features. Two protection modes are implemented (auto restart mode and latch mode), which can be entered. Protection features can be configured by the parameters that are shown in **Table 3-9** and **Table 3-10**. An error counter counts errors up to 4 restarts, defined by the constant value `Err_restart_tries` (see **Table 3-14**). The error counter is reset when the device operates without additional errors for the time defined by the constant `Err_cnt_clear_time` (see **Table 3-14**), or at the startup sequence, e.g. if V_{CC} falls below the voltage threshold (see **Table 4-4**).

Table 3-5. Protection Features

Undervoltage Protection for DC Input Line – V_{IN} Undervoltage	Section 3.6.1
Overvoltage Protection for DC Input Line – V_{IN} Overvoltage	Section 3.6.2
Output Undervoltage Protection – V_{OUT} Undervoltage	Section 3.6.3
Open Output Protection	Section 3.6.4
Output Overvoltage Protection – V_{OUT} Overvoltage	Section 3.6.5
Output Overpower Protection – P_{OUT} Overpower	Section 3.6.6
Overtemperature Protection	Section 3.6.7
Overcurrent Protection – Level 2 (OCP2)	Section 3.6.8
Functional Protections	Section 3.6.9

Functional Description

Protection functions are shown in a matrix in [Table 3-6](#) below.

Table 3-6. Protection Functions Matrix

Description of Fault	Characteristics of Fault		Operating Mode Detection Active					Consequence
	Name of Fault	Minimum Duration of effect	Startup	Normal	Shutdown	Error Current	Buck OFF	
V _{IN} Undervoltage	INPUV	1.6 ms	X	X	-	-	-	Startup - Waits until condition is removed Normal – Auto-restart
V _{IN} Overvoltage	INPOV	1.6 ms	X	X	-	-	-	Startup - Waits until condition is removed Normal – Auto-restart
V _{OUT} Undervoltage	OUTUV	0.8 ms @40 kHz	-	X	-	-	-	Auto-restart mode with 4 tries (restarts). After 4 failed attempts, the device enters latch mode
Open Output	OPEN	¹⁾	X	X	-	-	-	Auto-restart mode with 4 tries (restarts). In each restart try, I-set procedure will be executed. After 4 failed attempts, the device enters latch mode
V _{OUT} Overvoltage	OUTOV	0.4 ms @40 kHz	-	X	-	-	-	Auto-restart mode with 4 tries (restarts). After 4 failed attempts, the device enters latch mode
P _{OUT} Overpower	PWR	6.4 ms @40 kHz	-	X	-	-	-	Auto-restart mode with 4 tries (restarts). After 4 failed attempts, the device enters latch mode
Overtemperature (Internal or External)	OTI or OTE	0.4 ms @40 kHz	X	X	-	-	-	Startup - Waits until condition is removed Normal – Auto-restart
OCP2	OCP	Instantly	X	X	-	-	-	The device is in predefined time loop until the device is switched off or when the cause of the OCP2 event is removed – see Section 3.6.8
X = Checked during Operating Mode - = Not checked during Operation Mode								
In each restart attempt, the IC remains in a time loop whose duration is determined by the constant Err_restart_time, see Table 3-14								

¹⁾ Defined by constant Open_out_timeout, see [Section 3.6.4](#) .

All protections are described in the following sections.

3.6.1 Undervoltage Protection for DC Input Line – V_{IN} Undervoltage

Undervoltage protection for the DC input line prevents the device from operating with an excessively low V_{IN} voltage. If the input voltage is below the specified value, the output current is turned off. The device waits until the input undervoltage (low voltage value) condition is removed ($V_{in_min_start}$ is met) and then starts with output current generation again. There are two hysteric input voltage values that are used as thresholds during the startup sequence (upper threshold value – parameter $V_{in_min_start}$, see [Table 3-9](#))¹ and during operation (lower threshold value – parameter $V_{in_min_oper}$, see [Table 3-9](#))¹. If the input voltage is $V_{IN} < V_{in_min_oper}$ during operation, the buck converter will be shut down and will wait for the V_{IN} startup condition (when $V_{in_min_start}$ is reached). This event does not affect the error counter.

3.6.2 Overvoltage Protection for DC Input Line – V_{IN} Overvoltage

Overvoltage protection for the DC input line prevents the device from operating with an excessively high V_{IN} voltage. After the overvoltage condition on input is detected, the output current is turned off. The device waits for the input overvoltage condition to be removed ($V_{in_max_start}$ is met) and then starts output current generation again. There are two hysteric input voltage values that are used as thresholds during the startup sequence (lower threshold value – parameter $V_{in_max_start}$, see [Table 3-9](#))¹ and during operation (upper threshold value – parameter $V_{in_max_oper}$, see [Table 3-9](#))¹. If the input voltage is $V_{IN} > V_{in_max_oper}$ during operation, the buck converter will be shut down and will wait for the V_{IN} startup condition (when $V_{in_max_start}$ is reached). This event does not affect the error counter.

3.6.3 Output Undervoltage Protection – V_{OUT} Undervoltage

Output undervoltage protection prevents the device from operating with an excessively low output voltage V_{LEDmin} or when LED output is lowered. If the output voltage is lower than the minimum value $V_{OUT} < V_{out_min}$, an undervoltage output is detected, and the device enters error auto-restart mode with 4 tries (restarts) – constant $Err_restart_tries$ (see [Table 3-14](#)). After 4 failed attempts, the device enters latch mode. The minimum output operating voltage value is programmable (parameter V_{out_min} , [Table 3-9](#)). Undervoltage output is checked during steady-state condition, after completing soft-start. The restart timeout startup delay is predefined by the constant $Err_restart_time$ (see [Table 3-14](#)).

3.6.4 Open Output Protection

Open output protection prevents the device from operating when no load on output is detected. It is detected when the time to achieve I_{MAX} (see [Figure 11](#)) exceeds the value of the parameter $Open_out_timeout$ (see [Table 3-14](#))². If the open output condition is detected, the device enters error auto-restart mode with 4 tries (restarts) – constant $Err_restart_tries$ (see [Table 3-14](#)). In each attempt, the device executes the reference resistor reading procedure (I-set procedure, see [Section 3.3.3](#)). The duration of the I-set procedure is defined by the parameter $RC_measurement_timeout$ (duration = $2 \cdot RC_measurement_timeout$, see [Table 3-19](#)). The restart timeout startup delay is predefined by the constant $Err_restart_time$ (see [Table 3-14](#)). After 4 failed attempts, the device enters latch mode. The total duration of the restart attempt can be obtained as the sum of the two above-mentioned times (I-set procedure + restart timeout). If the LED lighting load is connected (or replaced) at the output between two restart attempts, the I-set procedure will detect the new R_{iset} resistance and the buck converter will try to start with the newly determined reference current.

¹ To minimize the impact of fluctuations on the exact V_{IN} voltage value, filtering is implemented using a first-order filter whose coefficient is defined by the constant $V_{in_filt_coef}$ (see [Table 3-14](#))

² During buck 'on time' T_{ON} (see [Figure 11](#)), the gate driver stays constantly 'high' until I_{MAX} is reached, or $Open_out_timeout$ expires. This can lead to a long 'high' time. In case there is a 'high side driver' circuit between the ILD2111 gate drive and MOSFET gate, proper functionality for all operating conditions needs to be considered. A stable OCP1 value (I_{MAX}) is obtained by filtering defined by the constant $Alt_OCP1_filt_stable$ (see [Table 3-14](#))

3.6.5 Output Overvoltage Protection – V_{OUT} Overvoltage

Output overvoltage protection prevents the device from operating when the high voltage at the output V_{OUT} is detected¹. If the output voltage is higher than the maximum value $V_{OUT} > V_{out_max}$, the device enters error auto-restart mode with 4 tries (restarts) – constant `Err_restart_tries` (see [Table 3-14](#)). After 4 failed attempts, the device enters latch mode. The maximum output operating voltage value is programmable (parameter `Vout_max`, [Table 3-9](#)). Output voltage is checked during the steady-state condition, after completing soft-start. The restart timeout startup delay is predefined by the constant `Err_restart_time` (see [Table 3-14](#)).

3.6.6 Output Overpower Protection – P_{OUT} Overpower

Output overpower protection prevents damage to output components due to high output power². The maximum allowed output power value (parameter `Pout_max`, see [Table 3-9](#)) is set by the constants `Pout_corr_LC` and `Pout_corr_HC` (`Pout_max_lc = Pout_corr_LC · Pout_max` and `Pout_max_hc = Pout_corr_HC · Pout_max`) for low current and high current range respectively (see [Table 3-14](#)). The parameter `Ref_current_HCTH` decides between the low current and high current range (see [Table 3-14](#)). If the output power exceeds the maximum allowed operational value, the device enters error auto-restart mode with 4 tries (restarts) – constant `Err_restart_tries` (see [Table 3-14](#)). After 4 failed attempts, the device enters latch mode. Output overpower is checked during the steady-state condition after completing soft-start. The restart timeout startup delay is predefined by the constant `Err_restart_time` (see [Table 3-14](#)).

¹ Output voltage is internally calculated, based on V_{IN} and T_{ON} / T_{PWM} duty factor. Output voltage can be calculated approximately as $V_{OUT} = D \cdot V_{IN} = (T_{ON} / T_{PWM}) \cdot V_{IN}$ (all resistances and voltage drops of used components are neglected). To minimize the impact of fluctuations on the exact T_{PWM} period value, filtering is implemented using a first-order filter whose coefficient is defined by the parameter `Tpwm_filt_coef` (see [Table 3-14](#)).

² Output power is internally calculated, based on V_{IN} , I_{OUT} and T_{ON} / T_{PWM} ratio. The actual T_{ON} / T_{PWM} ratio (for true output power) also depends on parasitic effects (e.g. MOSFET diode reverse recovery time, additional circuit like high side driver). These parasitic effects are unknown to the chip calculation and need to be considered for choosing appropriate `Pout_max` values. To minimize the impact of fluctuations on the calculated P_{OUT} value, filtering is implemented using a first-order filter whose coefficient is defined by the parameter `Pout_filt_coef` (see [Table 3-14](#)) before comparing the output power against `Pout_max_lc` or `Pout_max_hc` thresholds.

3.6.7 Overtemperature Protection

The ILD2111 supports overtemperature protection by means of internal and external temperature sensors. If both internal temperature protection and external temperature protection requests for the current level change, the lower current level will prevail. If the external sensor is not used (disabled by configuration), only the internal temperature protection is processed.

3.6.7.1 Internal Temperature Sensor – Internal PWM Dimming 1

Internal temperature-based protection uses internal temperature sensor measurement for reduction of the output current in the case that device temperature increases. For this purpose, two temperature thresholds - T1 and T2 - are defined (parameters ITP_temperature_hot – T1 and ITP_temperature_critical – T2 increasing in value – see [Table 3-10](#)) as well as one up-slope (constant ITP_PWM_inc_step - [Table 3-15](#) and parameter ITP_PWM_inc_time_step - [Table 3-10](#)) and one down-slope (constant ITP_PWM_dec_step - [Table 3-15](#) and parameter ITP_PWM_dec_time_step - [Table 3-10](#)). Temperature thresholds can be set in steps of 1°C and slopes as percentages of the average current per minute. The output current level is reduced by PWM modulation with a programmable frequency rate – see [Figure 28](#).

There are three temperature-related operating conditions:

- Normal $T \leq T1$
- Hot $T1 < T \leq T2$
- Critical $T > T2$

Temperature measurement may lead to a change of operating state:

- In the critical state, the output current is off. An output current restart could be in hot or normal state (default).
If the device starts in hot mode, then the current is adjusted with the dedicated constant value (ITP_startup_PWM_hot = 50%, see [Table 3-15](#)). If it is in normal mode, it will start with 100% of the rated current.
- In the hot state, the current will be reduced (decreased) according to a constant-defined limit (TP_PWM_duty_min = 50%, see [Table 3-18](#)) and down-slope. If the device starts in hot mode, it will start with 100% of the rated current, but then the current is adjusted with the dedicated parameter (ITP_startup_PWM_hot = 50%). In normal mode, the full current level (100%) is started and kept stable (no change in current level).

The complete device behavior regarding operating temperature conditions is shown in [Figure 23](#), [Figure 24](#) and [Figure 28](#).

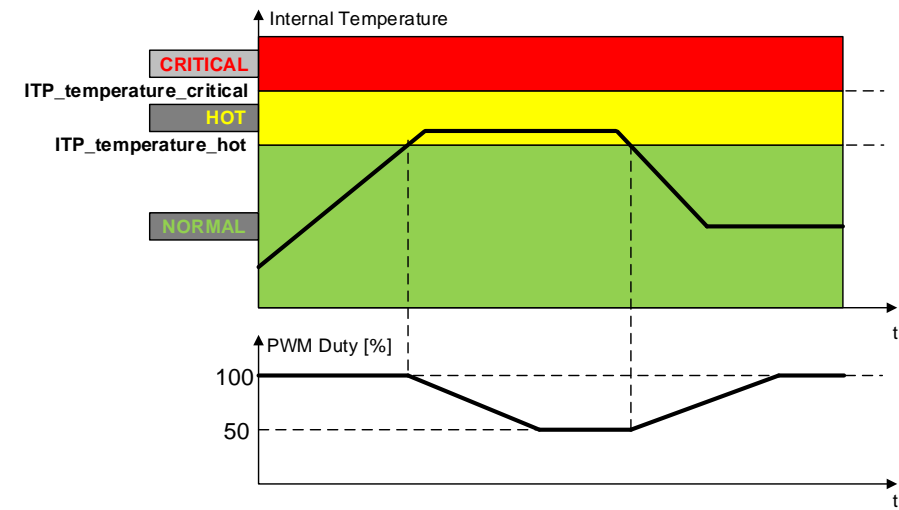

(a) Temperature exceeds `ITP_temperature_critical` threshold

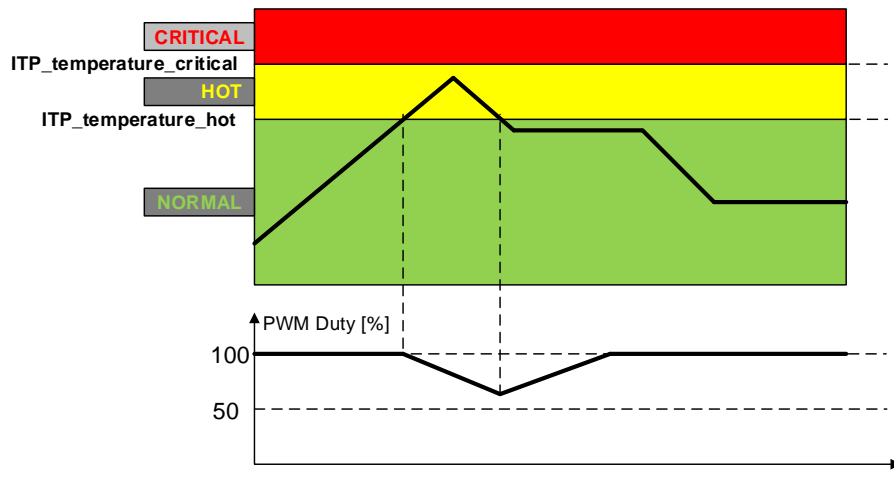

(b) Temperature exceeds `ITP_temperature_hot` threshold for longer time

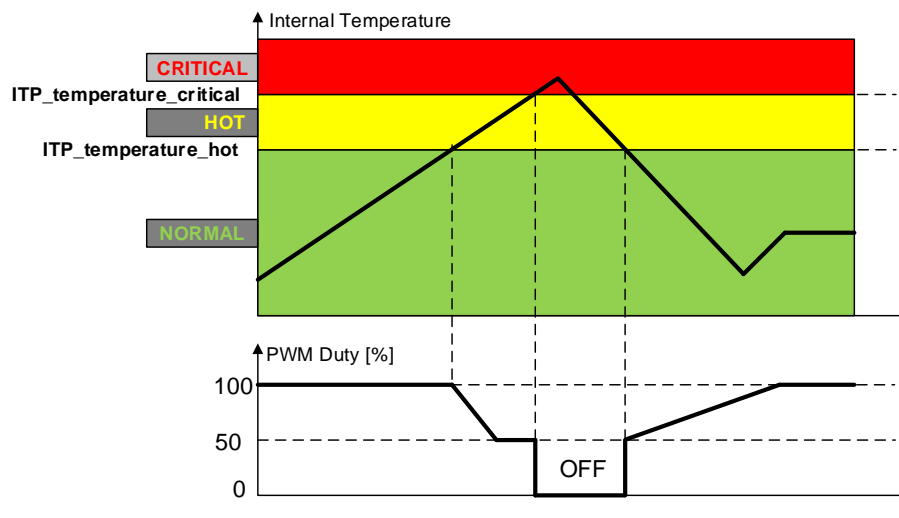

(c) Temperature exceeds `ITP_temperature_hot` threshold and stabilizes below `ITP_temperature_hot`

Figure 23. Internal Temperature Protection Behavior

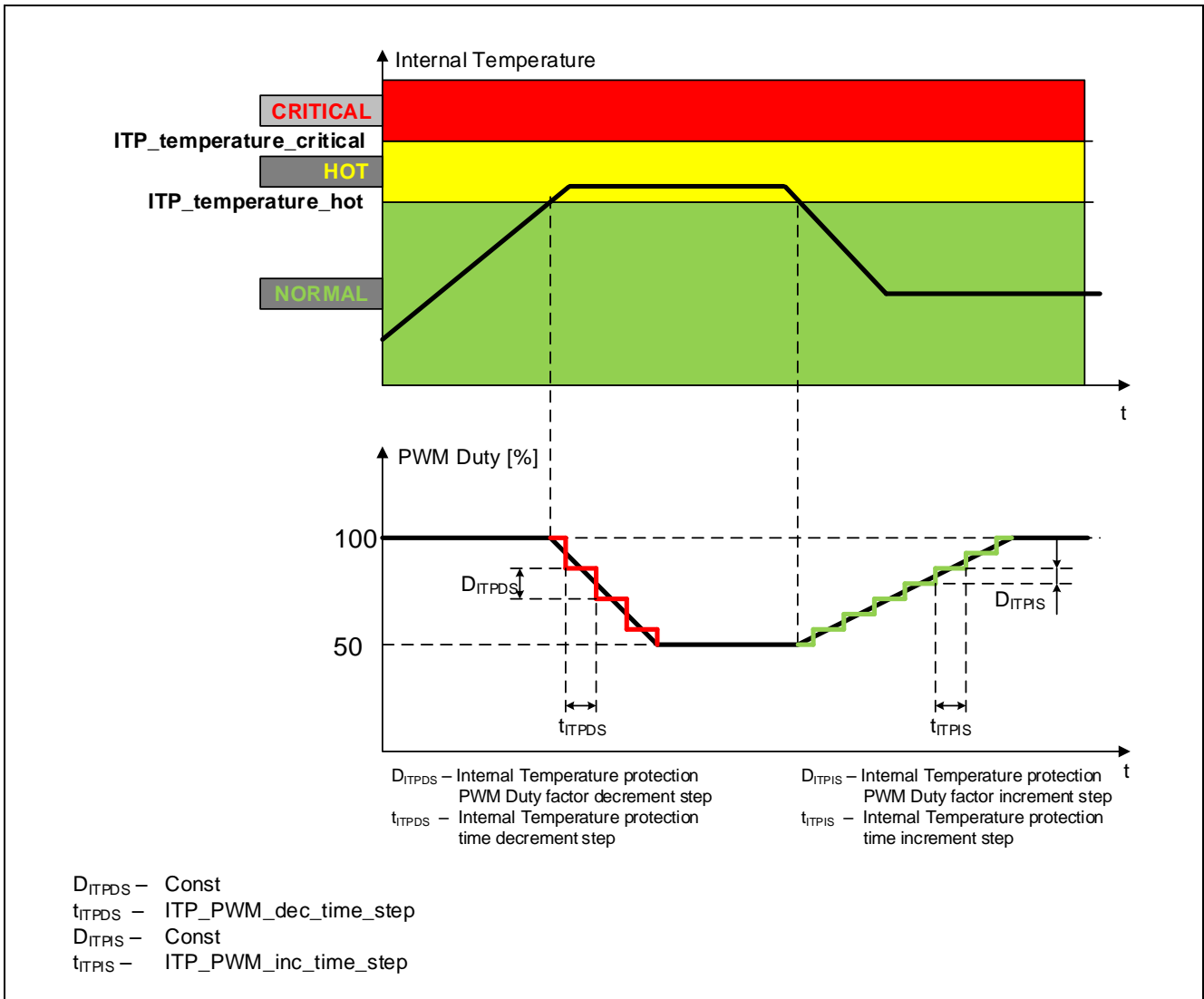

Figure 24. Internal Temperature Protection

3.6.7.2 External Temperature Sensor – Internal PWM Dimming 2

External temperature-based protection uses a PTC resistor connected to the TS pin and GND (2-wire connection – [Figure 25](#)). External temperature is meant to reduce the output current in the case that the temperature of the light element increases (see LED lighting in [Figure 25](#)). For this purpose, two temperature thresholds, T_{e1} and T_{e2} , are defined (parameters $ETP_temperature_hot - T_{e1}$ and $ETP_temperature_critical - T_{e2}$ increasing in value – see [Table 3-10](#)) as well as one up-slope (constant $ETP_PWM_inc_step$ - [Table 3-15](#) and parameter $ETP_PWM_inc_time_step$ - [Table 3-10](#)) and one down-slope (constant $ETP_PWM_dec_step$ - [Table 3-15](#) and parameter $ETP_PWM_dec_time_step$ - [Table 3-10](#)). Temperature thresholds can be set in steps of 1°C and slopes as percentages of the average current per minute. The output current level is reduced by PWM modulation with a programmable frequency rate – see [Figure 28](#). To minimize the impact of fluctuations on the exact external temperature value, filtering is implemented using a first-order filter whose coefficient is defined by the constant ETP_filt_coef (see [Table 3-15](#)) before comparing against thresholds.

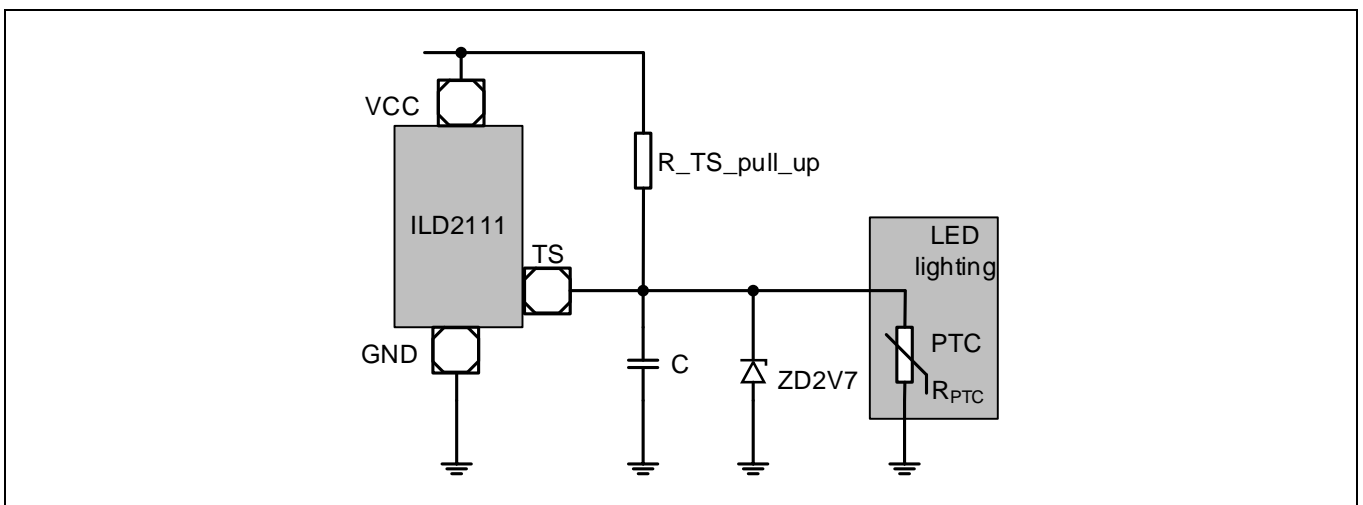

Figure 25. External Temperature Measurement

The external temperature sensor is supplied by V_{CC} , whose actual value is read by the on-chip ADC and used to calculate the external temperature value (the reference value for V_{CC} voltage compensation is defined by the parameter $VCC_reference$, see [Table 3-10](#))¹. The TS pin is clamped via a 2.7 V Zener diode for protection reasons.

The threshold levels vary according to the PTC resistance/temperature curve.

There are three temperature-related operating conditions:

- Normal $T \leq T_{e1}$
- Hot $T_{e1} < T \leq T_{e2}$
- Critical $T > T_{e2}$

Temperature measurement may lead to changes in the operating state²:

- In the critical state, the output current is off. An output current restart could be in hot or normal state (default).
If the device starts in hot mode, then the current is adjusted with the dedicated parameter ($ETP_startup_PWM_hot = 50\%$, see [Table 3-15](#)). If it is in normal mode, it will start with 100% of the rated current.

¹ To minimize the impact of fluctuations on the exact V_{CC} voltage value, filtering is implemented using a first-order filter whose coefficient is defined by the parameter Vin_filt_coef (see [Table 3-14](#))

² External temperature protection behavior curves have the same shape as internal temperature protection curves – see [Figure 23](#) (a, b and c).

Functional Description

- In the hot state, the current will be reduced (decreased) according to a parameter-defined limit (TP_PWM_duty_min, see [Table 3-18](#)) and down-slope. If the device starts in hot mode, then the current is adjusted with the dedicated parameter (ETP_startup_PWM_hot = 50%). If it is in normal mode, it will start with 100% of the rated current.
- In normal mode, the full current level (100%) will be kept (no change in current level). For startup in normal mode, 100% of the rated current will be generated at the output.

There is an additional ADC voltage threshold (constant ETP_temperature_disconnected, see [Table 3-13](#)) to improve existing functionality. It is not the temperature threshold. An ETP_temperature_disconnected internal threshold value signals that the ADC (voltage) value is too high – i.e., that the sensor is disconnected. If the sensor is disconnected during operation, PWM duty will be gradually reduced to a value defined by the constant TP_PWM_duty_min = 50% (see [Table 3-18](#)) as it is at a temperature defined by ETP_temperature_hot (see [Figure 26](#)). If the higher ADC voltage (greater than the ETP_temperature_disconnected value) is detected during startup, the sensor will be ignored during operation.

External temperature protection behavior is shown in [Figure 26](#).

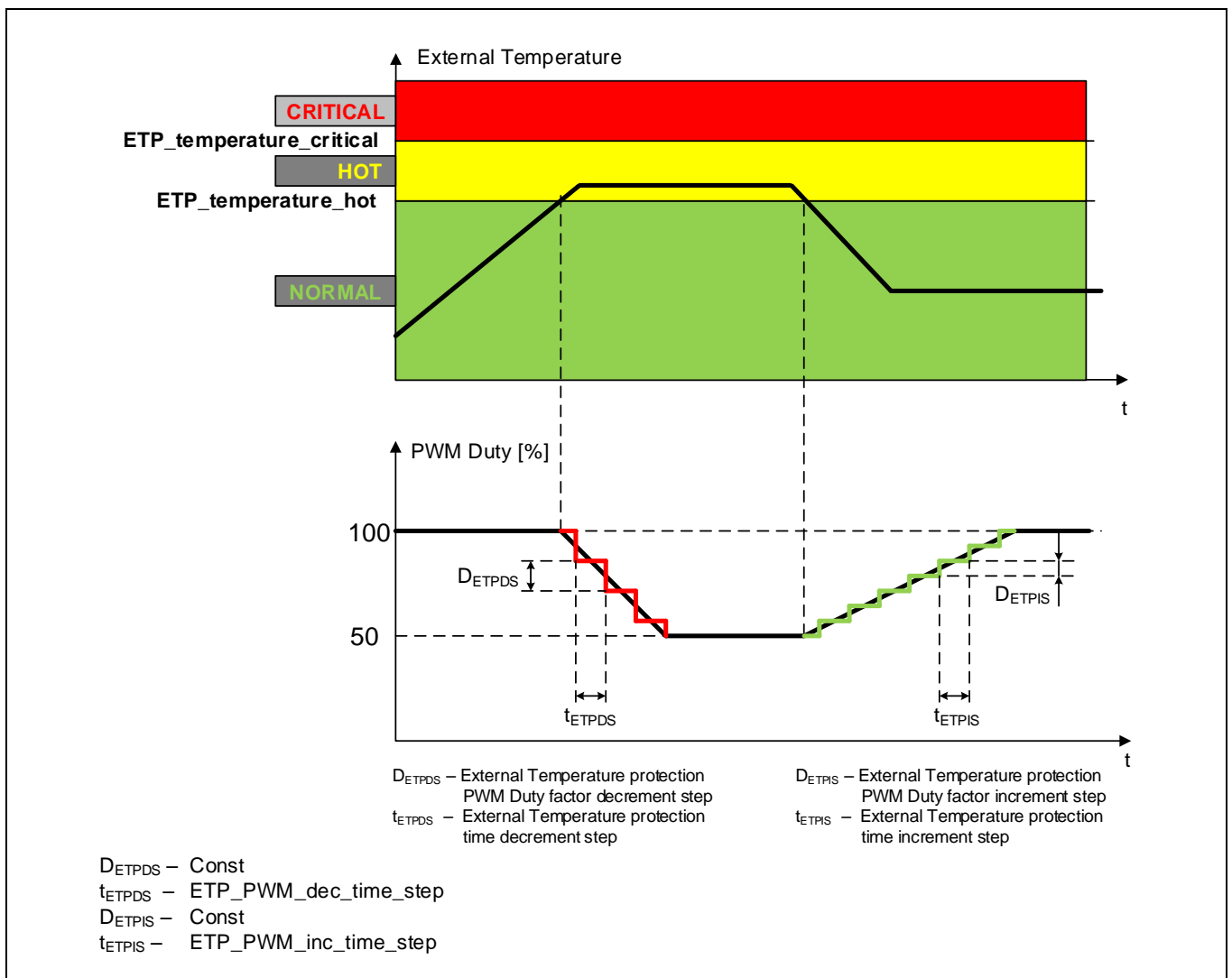

Figure 26. External Temperature Protection Behavior

3.6.8 Overcurrent Protection – Level 2 (OCP2)

To avoid damage to the shunt resistor or MOSFET due to the rapid increase (inrush) of the current through the shunt resistor (detected as the voltage at the CS pin), the overcurrent protection OCP2 is implemented as a hardware threshold. If the OCP2 threshold is reached¹ (regardless of the cause of its appearance), the gate driver (power MOSFET) will be turned off automatically and can only be turned on again by firmware intervention. In the case of an OCP2 event, the firmware checks an internal counter of OCP2 events and applies a delay according to the table [Table 3-7](#). After the delay the engine is reinitialized and the device starts operation. The OCP2 counter will be reset after a predefined time (constant `Err_cnt_clear_time`, see [Table 3-14](#)) in case there are no new OCP2 error events in the meantime. Otherwise, if the OCP2 event occurs again before the counter is reset, the number of errors is increased in increments up to the limit.

Table 3-7. OCP2 Error Restart Delay

Number of the OCP2 events	Previous value of the OCP2 counter	Next value of the OCP2 counter	Restart delay
1	0	1	100 μ s
2	1	2	500 μ s
3	2	3	2500 μ s
≥ 4	3	3	OCP2_restart_delay [ms]

The time loop defined by the constant `OCP2_restart_delay` (see [Table 3-14](#)) is repeated until the device is switched off or when the cause of the OCP2 event is removed.

If the OCP2 condition is removed and the device is in internal or external PWM dimming, the device continues to operate in one of two modes (internal or external dimming), depending on which of the conditions for these modes is fulfilled.

3.6.9 Functional Protections

Beside previous protections related to an application, ILD2111 incorporated the functional protections in order to achieve high reliability of the operation.

3.6.9.1 Code Memory Protections

During the startup of the device, after a reset or power-up, firmware is copied from the OTP memory to the RAM. The firmware is then executed from the RAM. The firmware is signed with a CRC value (Cyclic Redundancy Check). During the process of copying, the CRC value is calculated and then compared to the signed CRC value. In the case of a mismatch the firmware will not start in order to prevent misbehavior.

During run time the RAM is protected by a parity check over one memory cell. RAM parity protection is a hardware feature which detects parity errors when RAM is accessed (read/write). In the event of a parity error, a hardware reset is issued and the device will restart accordingly.

3.6.9.2 Firmware Hang Protection

During run-time, the execution of the firmware can become erratic due to a hardware fault. In order to prevent such firmware “hangs” a watch dog timer (WDT) is utilized. The WDT is a hardware feature and if it is not serviced before a specific timeout, the device will reset and restart accordingly.

3.6.9.3 Parameter Memory Protection

The parameter memory is a dedicated part of the RAM. The device blank checks part of this area and also checks for the parameter “CRC error”. More details can be found in [Section 3.9.2](#).

¹ The digital representative of the OCP2 comparator output is digitally filtered. The number of successive samples that have reached OCP2 level, after which OCP2 event will be acknowledged, is defined by the parameter `OCP2_filt_stable` (see [Table 3-14](#)).

3.7 External PWM Dimming

For external dimming, EPWM duty (DT_{EPWM} - duty factor range 1% to 99%) and EPWM period (T_{EPWM}) can be measured at the PWM input pin – see [Figure 27](#).

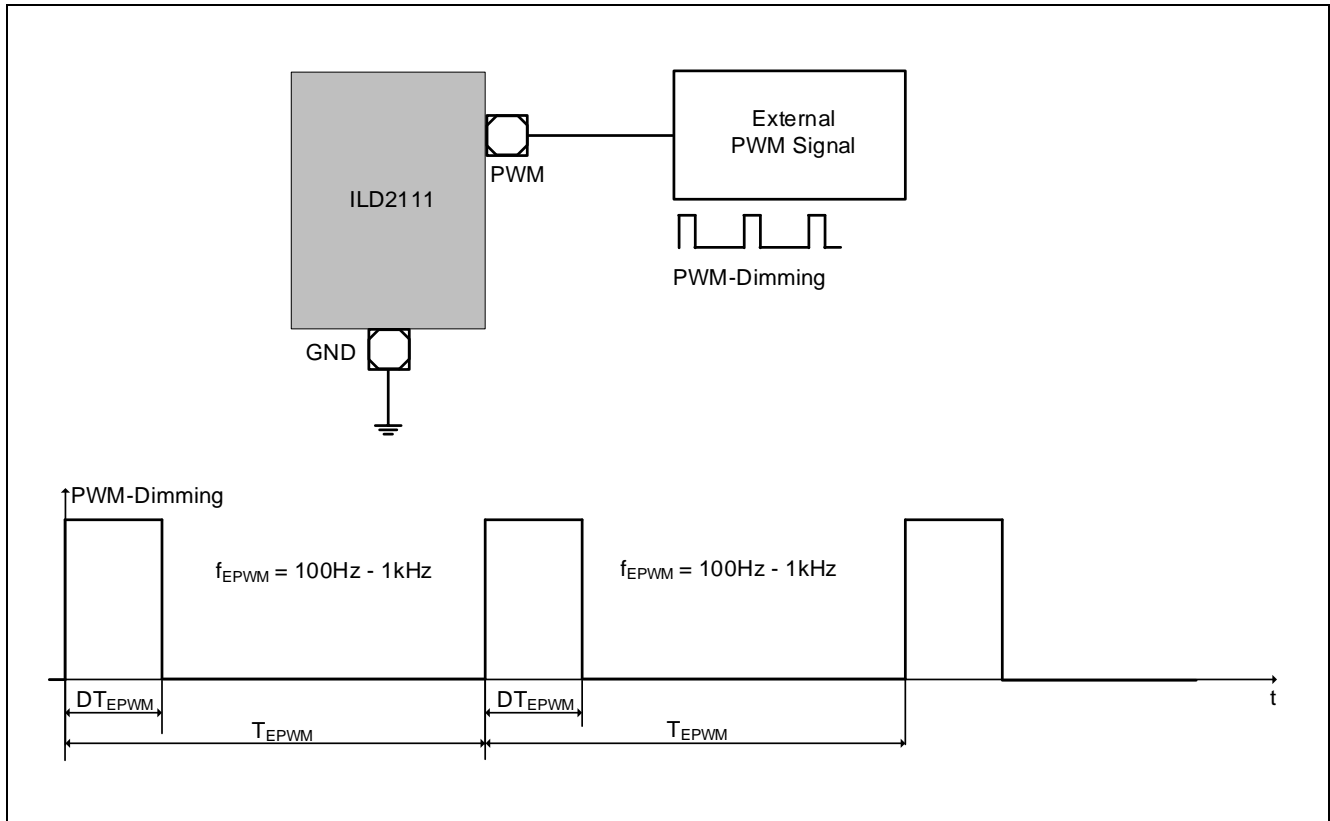

Figure 27. External PWM Dimming

The external PWM duty factor and external PWM frequency are obtained by measuring the on-time T_{ON_EPWM} (DT_{EPWM}) and PWM period T_{EPWM} . The timeout time for external PWM detection is defined by the constant `EPWM_detection_timeout` (see [Table 3-18](#)). There are two additional parameters that are used for external PWM processing: 1. `LFPWM_threshold_divider`, which represents the number of divisions by two of the measured T_{EPWM} to obtain the hysteretic controller threshold and 2. `LFPWM_flicker_free_threshold` which represents the number of switching cycles that are considered flicker-free (the threshold divider is then not implemented for the hysteresis controller) – see [Table 3-18](#). The complete output current PWM modulation is described in the following section [3.8](#).

3.8 Output Current PWM Modulation

Modulation of the output current can be requested by either of the following:

1. External PWM dimming signal (Section 3.7) and
2. Internal PWM dimming signal (internal temperature protection – see Section 3.6.7.1 and external temperature protection – see Section 3.6.7.2).

The output current dimming PWM frequency, f_{PWM} , will be defined by the external PWM dimming signal EPWM (the range of f_{EPWM} is 100 Hz – 1 kHz; $f_{EPWM} = 1 / T_{PWM}$) or by the internal PWM signal (IPWM – constant value $T_{P_PWM_period} = 3.2$ ms, f_{IPWM} is 300 Hz, $f_{IPWM} = 1 / T_{PWM}$, see Table 3-18), if EPWM is not detected (the external EPWM frequency has a higher priority than the internal IPWM frequency). The final duty factor (PWM_Duty, see Figure 28) of the PWM signal will be determined by a minimum value of one of two calculated values (external $epwm_duty$ or internal $ipwm_duty$).

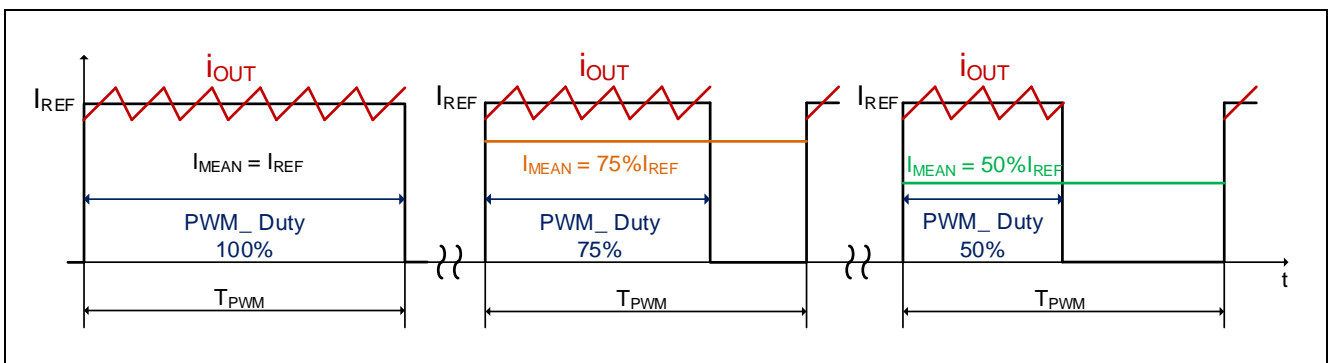

Figure 28. Output Current PWM Modulation

A hysteretic controller is implemented in order to have a flicker-free output even at low dimming levels. This controller monitors the PWM duty and the high switching frequency period (buck cycle, $T = T_{ON} + T_{OFF}$) and uses this information to control a number of switching cycles (N) within the PWM ON time. This number is updated only upon changes that are sufficiently high. The threshold is set to $T_{old} / 2^{LFPWM_threshold_divider}$. Therefore either the PWM ON time changes to that extent or T changes such that $|T_{new} \cdot N + T_{ON_FIRST} - T_{PWM_ON}| > T_{old} / 2^{LFPWM_threshold_divider}$. From the previous description it can be seen that the compensation for the first rising slope time (T_{ON_FIRST}) is included in the calculation.

The hysteretic cycle control requires reaching of the OCP1 level (I_{MAX}) a minimum of three times, i.e. a minimum of two switching cycles $2 \cdot (T_{ON} + T_{OFF})$ plus a rising T_{ON_FIRST} and falling T_{OFF_LAST} times in order to perform proper measurements and to regulate the current and implement protection features. Therefore, the minimum pulse width (T_{PWM_ON}) of the output PWM dimming current is restricted according to this minimum duration (see Figure 29). The mean output current is proportional to the duty. However, for low duty, accuracy is lower due to limits mentioned earlier. Furthermore, the higher the output reference current value I_{REF} , the greater the expected inaccuracy due to longer rising T_{ON_FIRST} and falling T_{OFF_LAST} times.

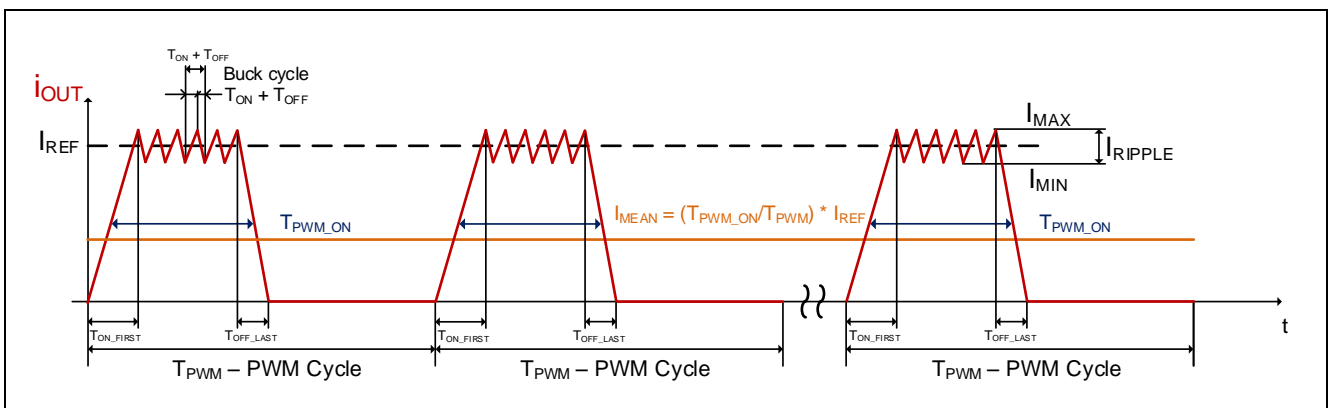

Figure 29. Output Current I_{MEAN} Dimming Range Limitation

3.9 Configuration

This section provides an overview of the parameters that can be configured via the UART interface.

3.9.1 Overview of Configurable Parameters

The ILD2111 provides a generic firmware version that includes all parameters set to zero. The parameter values need to be specified by the user according to the target application.

Please refer to the corresponding electrical characteristics in Section 4 for the minimum and maximum tolerances.

Parameter Lists

The parameter list contains the following groups:

- Configurable parameters (see Section 3.9.1.1) - Variable values that can be changed (modified) by the user according to the desired application.
- Design constants (see Section 3.9.1.2) - Constant values that cannot be changed and that are specified by the application.

3.9.1.1 Configurable Parameters

The configurable parameters are arranged in the following tables:

1. Hardware configuration - [Table 3-8](#).
2. Protections - [Table 3-9](#).
3. Temperature guard - [Table 3-10](#).
4. Startup & shutdown - [Table 3-11](#).
5. Output current set - [Table 3-12](#).

Table 3-8. Configurable Parameters – Hardware Configuration

Parameter Name	Minimum Value	Maximum Value	Description
Vin_current_range	0.209 mA	1.6 mA	This bit field selects the measurement range for the current measurement (full scale value) 00 _B - Range 00 => I _{MEA} = 209 μA (R _{SHUNT} = 6690 Ω) 01 _B - Range 01 => I _{MEA} = 1.6 mA (R _{SHUNT} = 1490 Ω)
Current_sense_OCP1	0.4 V	0.6 V	This bit field defines range (gain) for the CS OCP1 DAC, CS S&H and CS peak detector 10 _B - Range 10 = OCP1 = 0.6 V / OCP2 = 0.8 V (gain = 4) 11 _B - Range 11 = OCP1 = 0.4 V / OCP2 = 0.6 V (gain = 6)
GD_voltage	4.5 V	15 V	Gate voltage settings 000 _B – 15 V 001 _B – 13.5 V 010 _B – 12 V 011 _B – 10.5 V 100 _B – 9 V 101 _B – 7.5 V 110 _B – 6 V 111 _B – 4.5 V
GD_current	30 mA	118 mA	Gate current settings 00110 _B – 30 mA 00111 _B – 33 mA 01000 _B – 35 mA 01001 _B – 38 mA 01010 _B – 41 mA 01011 _B – 45 mA 01100 _B – 49 mA 01101 _B – 53 mA 01110 _B – 57 mA 01111 _B – 62 mA 10000 _B – 67 mA 10001 _B – 73 mA 10010 _B – 79 mA 10011 _B – 85 mA 10100 _B – 93 mA 10101 _B – 100 mA 10110 _B – 109 mA 10111 _B – 118 mA

Table 3-9. Configurable Parameters - Protections

Parameter Name	Minimum Value	Maximum Value	Description
ETP_comp_Vcc			Vcc voltage compensation for external temperature measurement enabled/disabled
ETP_enable			External temperature protection feature enabled/disabled
Vin_min_start	0		Lowest possible input voltage V_{IN} for buck converter to be able to start operation.
Vin_min_oper	0		Lowest possible input voltage V_{IN} allowed during operation.
Vin_max_start	0		Highest possible input voltage V_{IN} for buck converter to be able to start operation
Vin_max_oper	0		Highest possible input voltage V_{IN} allowed during operation.
Vout_min	0		Minimum output voltage. Output voltage lower than this value will trigger output undervoltage protection.
Vout_max	0		Maximum output voltage. Output voltage higher than this value will trigger output overvoltage protection.
Pout_max	0		Maximum allowed output power – Output power higher than this value will trigger output overpower protection. The output power limit can be for $Ref_currents < Ref_current_HCTH$ or for $Ref_currents \geq Ref_current_HCTH$, see Table 3-14
Err_refcurrent_max			Maximal hysteretic value of shutdown output current (ERROR CURRENT) - I_{ERROR} , see Figure 13
Err_refcurrent_min			Minimal hysteretic value of shutdown output current (ERROR CURRENT) - I_{ERROR} , see Figure 13

Table 3-10. Configurable Parameters – Temperature guard

Parameter Name	Minimum Value	Maximum Value	Description
ITP_temperature_hot ¹⁾	-40 °C	150 °C	Hot temperature threshold for internal sensor.
ITP_temperature_critical ¹⁾	-40 °C	150 °C	Critical temperature threshold for internal sensor.
ETP_temperature_hot	0 V	1.6 V	Hot temperature voltage threshold for external sensor.
ETP_temperature_critical	0 V	1.6 V	Critical temperature voltage threshold for external sensor.
ITP_PWM_inc_time_step	1 s	100 s	Internal temperature protection time step (in seconds) for current increasing (change of internal PWM duty).
ITP_PWM_dec_time_step	1 s	100 s	Internal temperature protection time step (in seconds) for current decreasing (change of internal PWM duty).
ETP_PWM_inc_time_step	1 s	100 s	External temperature protection time step (in seconds) for current increasing (change of internal PWM duty).

Functional Description

Parameter Name	Minimum Value	Maximum Value	Description
ETP_PWM_dec_time_step	1 s	100 s	External temperature protection time step (in seconds) for current decreasing (change of internal PWM duty).
Vcc_reference	11 V	24 V	Reference value of Vcc voltage for external temperature measurement compensation.

¹⁾ Absolute maximum ratings and operation conditions need to be considered.

Table 3-11. Configurable Parameters – Startup & Shutdown¹⁾

Parameter Name	Minimum Value	Maximum Value	Description
Softstart_time_step	0	65535	Reference current ramp increment time interval (t_{CSUS}) in system timer ticks (100 μ s).
Softshutdown_time_step	0	65535	Reference current ramp decrement time interval (t_{CSDS}) in system timer ticks (100 μ s).

¹⁾ See Section 3.3.5.

Table 3-12. Configurable Parameters – Output Current Set¹⁾

Parameter Name	Minimum Value	Maximum Value	Description
Curr_ripple_perc	1	100	Current ripple percentage which is used during the startup sequence.
Ref_current_01			Reference current 01 which is assigned to the first FRC current group (FRC current group 1).
Ref_current_02			Reference current 02 which is assigned to the first FRC current group (FRC current group 1).
Ref_current_03			Reference current 03 which is assigned to the first FRC current group (FRC current group 1).
Ref_current_04			Reference current 04 which is assigned to the first FRC current group (FRC current group 1).
Ref_current_05			Reference current 05 which is assigned to the second FRC current group (FRC current group 2).
Ref_current_06			Reference current 06 which is assigned to the second FRC current group (FRC current group 2).
Ref_current_07			Reference current 07 which is assigned to the second FRC current group (FRC current group 2).
Ref_current_08			Reference current 08 which is assigned to the second FRC current group (FRC current group 2).
Ref_current_09			Reference current 09 which is assigned to the third FRC current group (FRC current group 3).
Ref_current_10			Reference current 10 which is assigned to the third FRC current group (FRC current group 3).
Ref_current_11			Reference current 11 which is assigned to the third FRC current group (FRC current group 3).
Ref_current_12			Reference current 12 which is assigned to the third FRC current group (FRC current group 3).
Ref_current_13			Reference current 13 which is assigned to the fourth FRC current group (FRC current group 4).
Ref_current_14			Reference current 14 which is assigned to the fourth FRC current group (FRC current group 4).
Ref_current_15			Reference current 15 which is assigned to the fourth FRC current group (FRC current group 4).
Ref_current_16			Reference current 16 which is assigned to the fourth FRC current group (FRC current group 4).

¹⁾ See Section 3.3.3.

3.9.1.2 Design Constants

Design constants are arranged in the following tables:

1. Hardware configuration - [Table 3-13](#).
2. Protections - [Table 3-14](#).
3. Temperature guard - [Table 3-15](#).
4. Startup & shutdown - [Table 3-16](#).
5. Control loop - [Table 3-17](#).
6. Dimming - [Table 3-18](#).
7. Output current set - [Table 3-19](#).
8. Frequency ripple controller - [Table 3-20](#).

Table 3-13. Design Constants – Hardware Configuration

Parameter Name	Value	Description
V_ADC_th	0.6075 V	Ref capacitor discharge ADC voltage threshold.
ETP_temperature_disconnected	4000 i.u	External sensor disconnection threshold value.

Table 3-14. Design Constants – Protections

Parameter Name	Value	Description
Ref_current_HCTH	800 mA	First reference current value for HC range. The value should be selected from the reference current list.
Pout_corr_LC	1	P _{OUT} correction factor for low current (LC) range.
Pout_corr_HC	1	P _{OUT} correction factor for high current (HC) range.
Err_restart_tries	4	Number of auto-restart attempts before entering latch mode.
Err_current_time	500 ms	Time interval (error time) after decreasing ramp to imply minimum current before turn off.
Err_restart_time	1000 ms	Error auto-restart time interval.
Err_cnt_clear_time	65000 ms	Time after which error restart attempts counter will be cleared.
Open_out_timeout	300 ms	Open output detection time (timeout).
Alt_OCP1_filt_stable	2	ALTOCP1 filter length (OCP1 level).
OCP2_filt_stable	6	Number of samples that have reached OCP2 level, after which OCP2 event will be handled.
Pout_filt_coef	16	Output power first order filter coefficient. This parameter can be 2 ⁿ (n = 0, 1, 2, 3, 4, 5, 6, 7, 8). Pout filtering before comparing against Pout_max_XX, (XX = LC, HC) threshold.
Vin_filt_coef	16	Vin voltage first order filter coefficient. This parameter can be 2 ⁿ (n = 0, 1, 2, 3, 4, 5, 6, 7, 8).
Tpwm_filt_coef	4	Tpwm (Buck cycle period) first order filter coefficient. This parameter can be 2 ⁿ (n = 0, 1, 2, 3, 4, 5, 6, 7, 8).
OCP2_restart_delay	130 ms	Final delay time after four OCP2 events are detected.
Buck_steady_delay	32	Number of averaged PWM cycles for steady state operation where calculation & protection are handled.

Table 3-15. Design Constants – Temperature Guard

Parameter Name	Value	Description
ITP_PWM_inc_step	1	Internal temperature protection current increase step (internal PWM dimming).
ITP_PWM_dec_step	1	Internal temperature protection current decrease step (internal PWM dimming).
ITP_startup_PWM_hot	50%	Internal temperature protection current de-rating PWM duty value for starting in the hot condition.
ETP_PWM_inc_step	1	External temperature protection current increase step (internal PWM dimming).
ETP_PWM_dec_step	1	External temperature protection current decrease step (internal PWM dimming).
ETP_startup_PWM_hot	50%	External temperature protection current de-rating PWM duty value for starting in the hot condition.
ETP_filt_coef	64	External temperature measurement first order filter coefficient. External temperature filtering before comparing against thresholds. This parameter can be 2^n ($n = 0, 1, 2, 3, 4, 5, 6, 7, 8$).
Vcc_filt_coef	16	Vcc voltage first order filter coefficient. This parameter can be 2^n ($n = 0, 1, 2, 3, 4, 5, 6, 7, 8$).

Table 3-16. Design Constants – Startup and Shutdown

Parameter Name	Value	Description
Softstart_start_curr	5%	Softstart starting value of reference current ramp (% of the I_ref_01 current value). Ripple is given as a percentage.
Softstart_curr_step	0.5%	Softstart reference current ramp increment step value (% of the I_ref_01 current value).
Softshutdown_curr_step	0.5%	Soft shutdown reference current ramp decrement step value (% of the I_ref_01 current value).

Table 3-17. Design Constant – Control Loop

Parameter Name	Value	Description
PI_gain_shift_softstart_lc	3	PI regulator gain boost value for low current range during startup. The error signal is multiplied with $2^{PI_gain_shift_softstart_lc}$.
PI_gain_shift_softstart_hc	2	PI regulator gain boost value for high current range during startup. The error signal is multiplied with $2^{PI_gain_shift_softstart_hc}$.
PI_gain_shift_lc	1	PI regulator gain boost value for low current range during normal operation. The error signal is multiplied with $2^{PI_gain_shift_lc}$.
PI_gain_shift_hc	0	PI regulator gain boost value for high current range during normal operation. The error signal is multiplied with $2^{PI_gain_shift_hc}$.

Table 3-18. Design Constant – Dimming

Parameter Name	Value	Description
TP_PWM_period	3.2 ms	Temperature protection internal IPWM period - defines the frequency of the internal IPWM dimming ($f_{PWM} = 1 / TP_PWM_period$). $f_{PWM} \sim 300$ Hz.
TP_PWM_duty_min	50%	Temperature protection internal IPWM ON time - defines the duty factor (in %) of the internal IPWM dimming.
EPWM_detection_timeout	50 ms	Timeout for external EPWM detection.
LFPWM_threshold_divider	1	Number of divisions by two of measured T_{PWM} to get the hysteretic controller threshold. This parameter can be $n = 0, 1, 2, 3, 4, 5, 6, 7, 8$.
LFPWM_flicker_free_threshold	30	Number of switching cycles that are considered flicker-free (threshold divider is not implemented then for hysteresis controller).

Table 3-19. Design Constant – Output Current Set

Parameter Name	Value	Description
Reference_time_01 ¹⁾	*	Discharge time threshold for Ref_current_01
Reference_time_02 ¹⁾	*	Discharge time threshold for Ref_current_02
Reference_time_03 ¹⁾	*	Discharge time threshold for Ref_current_03
Reference_time_04 ¹⁾	*	Discharge time threshold for Ref_current_04
Reference_time_05 ¹⁾	*	Discharge time threshold for Ref_current_05
Reference_time_06 ¹⁾	*	Discharge time threshold for Ref_current_06
Reference_time_07 ¹⁾	*	Discharge time threshold for Ref_current_07
Reference_time_08 ¹⁾	*	Discharge time threshold for Ref_current_08
Reference_time_09 ¹⁾	*	Discharge time threshold for Ref_current_09
Reference_time_10 ¹⁾	*	Discharge time threshold for Ref_current_10
Reference_time_11 ¹⁾	*	Discharge time threshold for Ref_current_11
Reference_time_12 ¹⁾	*	Discharge time threshold for Ref_current_12
Reference_time_13 ¹⁾	*	Discharge time threshold for Ref_current_13
Reference_time_14 ¹⁾	*	Discharge time threshold for Ref_current_14
Reference_time_15 ¹⁾	*	Discharge time threshold for Ref_current_15
Reference_time_16 ¹⁾	*	Discharge time threshold for Ref_current_16
RC_cap_charge_time	500 µs	Time for charging ref capacitor.
RC_measurement_timeout	40000 µs	Maximal time to determine that no external resistor has been connected during current set determination.
CS_blanking_time	0.758 µs	Configurable leading edge blanking time.
CS_sample_time	0.622 µs	Configurable CS sample time - delay until sampling starts.
Toff_min	0.4 µs	Minimal T _{OFF} time. It is 10% of T _{SWMIN} = 1 / f _{SWMAX} , f _{SWMAX} = 250 kHz.

¹⁾ The calculated Reference_time values* (dependent on the selected reference resistors and reference capacitor) will be assigned automatically to the appropriate reference current parameter Ref_current – see Section 3.3.3.

Table 3-20. Design Constant - Frequency Ripple Controller

Parameter Name	Value	Description
Curr_ripple_max_01_04	157 mA	Maximum allowed ripple value for reference currents group 1. FRC is enabled.
Curr_ripple_min_01_04	87 mA	Minimum allowed ripple value for reference currents group 1. FRC is enabled.
Curr_ripple_max_05_08	149 mA	Maximum allowed ripple value for reference currents group 2. FRC is enabled.
Curr_ripple_min_05_08	87 mA	Minimum allowed ripple value for reference currents group 2. FRC is enabled.
Curr_ripple_max_09_12	149 mA	Maximum allowed ripple value for reference currents group 3. FRC is enabled.
Curr_ripple_min_09_12	87 mA	Minimum allowed ripple value for reference currents group 3. FRC is enabled.
Curr_ripple_max_13_16	140 mA	Maximum allowed ripple value for reference currents group 4. FRC is enabled.
Curr_ripple_min_13_16	87 mA	Minimum allowed ripple value for reference currents group 4. FRC is enabled.
FRC_freq_max_limit_01_04	120 kHz	Maximum allowed switching frequency (defines minimum allowed switching period) for reference currents group 1.
FRC_freq_min_limit_01_04	110 kHz	Minimum allowed switching frequency (defines maximum allowed switching period) for reference currents group 1.
FRC_freq_max_limit_05_08	140 kHz	Maximum allowed switching frequency (defines minimum allowed switching period) for reference currents group 2.
FRC_freq_min_limit_05_08	126 kHz	Minimum allowed switching frequency (defines maximum allowed switching period) for reference currents group 2.
FRC_freq_max_limit_09_12	145 kHz	Maximum allowed switching frequency (defines minimum allowed switching period) for reference currents group 3.
FRC_freq_min_limit_09_12	130 kHz	Minimum allowed switching frequency (defines maximum allowed switching period) for reference currents group 3.
FRC_freq_max_limit_13_16	130 kHz	Maximum allowed switching frequency (defines minimum allowed switching period) for reference currents group 4.
FRC_freq_min_limit_13_16	110 kHz	Minimum allowed switching frequency (defines maximum allowed switching period) for reference currents group 4.
FRC_reg_interval_start	1024	Frequency-ripple control execution interval, during startup, in averaging intervals (averaging interval = 16 Buck cycles).
FRC_reg_interval_oper	12288	Frequency-ripple control execution interval during normal operation, in averaging intervals (averaging interval = 16 Buck cycles).
FRC_pass_oper_th	64	Number of FRC executions before considered steady and can switch to operational execution interval.

3.9.2 Configuration Procedure – Parameter Handling

The UART interface is configured at the pin REF/SC. The UART interface uses a single line for receiving and transmitting data. Firmware parameters are configured by means of communication protocol commands (Infineon proprietary protocol).

Parameters are stored in on-chip OTP memory (default parameter block and parameter patches).

Parameters can be accessed after the chip startup phase when V_{CC} exceeds the V_{EXT} threshold (see [Table 4-4](#)) and a UART connection at the REF/SC pin is detected.

During startup, the application checks the default parameter block, RAM content that was copied from OTP memory. If no default parameter block is detected or if an error is found (CRC mismatch), buck operation will be disabled, and the device will report an error and enter the idle state. Reading and writing of the parameters are related to RAM parameter values. Write operations change the working value of the selected parameter, affecting chip operation after exiting configuration mode. The number of write operations is not limited.

Since the default parameter block may be corrupted or in the case that the user wants to change some of the parameter values (or the whole parameter block), a patching feature can be used to change the parameters. In general, the patches will have the same structure as the default parameter block but the length will be arbitrary and up to the size of the full (default) block. A Cyclic Redundancy Check (CRC) in the patch will not reflect the patch data CRC, but rather the CRC of all the default parameters with the implemented patch. The patching procedure will be repeated for all found and consistent patches – see the parameter-handling flowchart in [Figure 30](#).

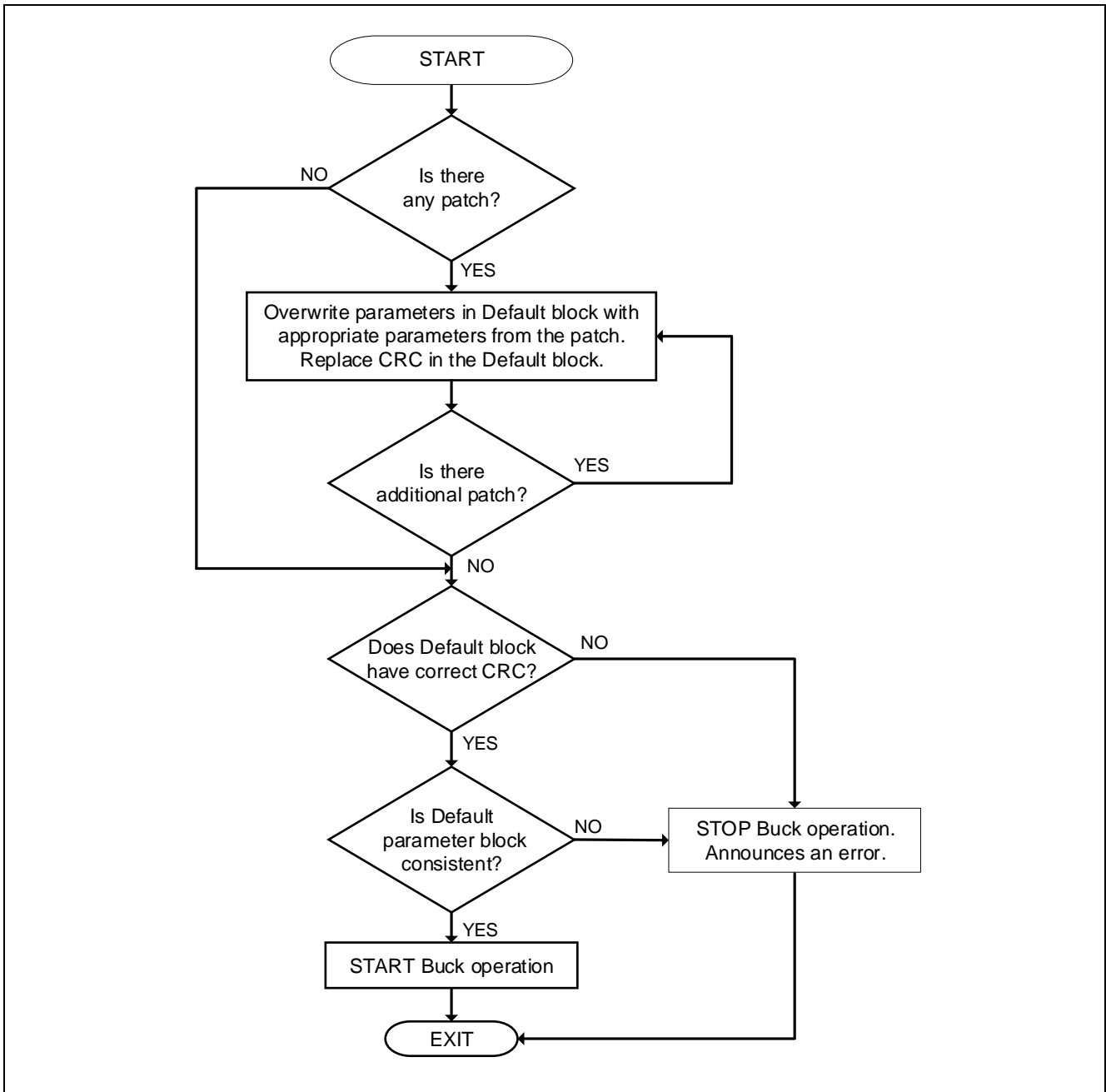

Figure 30. Parameter Handling

In order to be presented to users in a suitable, comprehensive form, the *.dp vision* Graphical User Interface (GUI) application is provided by Infineon. This software tool relates parameter addresses and values to their appropriate physical interpretation. Moreover, default parameter settings can be changed (recalculated) according to application requirements (input voltage range, output current range, shunt resistor value, input voltage resistor value, reference capacitor value, etc.) and can be burned according to recalculated values as well as writing the corresponding patches. Burning parameters to OTP¹ will store the current parameter values to be used as working values after the next chip reset.

More information about *.dp vision* can be found in the User's Manual document for this tool.

¹ During burning, the OTP programming voltage V_{PP} (see [Table 4-15](#)) must have a stable value.

4 Electrical Characteristics

4.1 Definitions

Figure 31 illustrates the definition for the voltage and current parameters used in this datasheet.

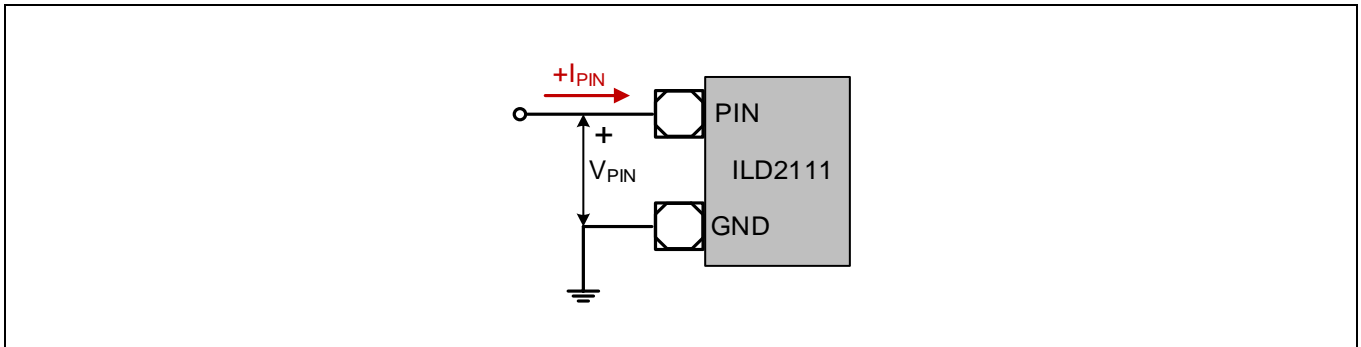

Figure 31. Voltage and Current Definitions¹

The electrical characteristics are arranged in the following tables:

- 1) Absolute Maximum Ratings, [Table 4-1](#).
- 2) Thermal Characteristics, [Table 4-2](#).
- 3) Operating Range, [Table 4-3](#).
- 4) Electrical Characteristics of the Power Supply, [Table 4-4](#).
- 5) Electrical Characteristics of Pin VIN, [Table 4-5](#).
- 6) Electrical Characteristics of Pin REF/SC, [Table 4-6](#).
- 7) Electrical Characteristics of Pin CS, [Table 4-7](#).
- 8) Electrical Characteristics of Gate Driver Pin GD0, [Table 4-8](#).
- 9) Electrical Characteristics of Digital Input Pin PWM, [Table 4-9](#).
- 10) Electrical Characteristics of Pin TS, [Table 4-10](#)
- 11) Electrical Characteristics of the A/D Converter, [Table 4-11](#).
- 12) Electrical Characteristics of the Reference Voltage V_{REF} , [Table 4-12](#).
- 13) Electrical Characteristics of the Clock Oscillators, [Table 4-13](#).
- 14) Electrical Characteristics for Internal Temperature Protection, [Table 4-14](#).
- 15) Electrical Characteristics of the OTP Programming, [Table 4-15](#).

¹ Currents flowing out of the device (ILD2111) are marked with a negative sign in the 'Symbol' column.

4.2 Absolute Maximum Ratings

Attention: Stresses above the values listed below may cause permanent damage to the device. Exposure to absolute maximum rating conditions for extended periods may affect device reliability. Maximum ratings are absolute ratings; exceeding only one of these values may cause irreversible damage to the integrated circuit.

These values are not tested during production test.

Table 4-1. Absolute Maximum Ratings¹

Parameter	Symbol	Values		Unit	Note / Test Condition
		Min.	Max.		
Voltage at pin VCC	V _{VCC}	-0.5	26	V	Voltage that can be applied to pin VCC by an external voltage source
Voltage at pin GD0	V _{GD0}	-0.5	V _{VCC} +0.3	V	
Voltage at pin PWM	V _{PWM}	-0.5	V _{VCC} +0.3	V	
Junction temperature	T _J	-40	125	°C	
Storage temperature	T _S	-55	150	°C	
Soldering temperature	T _{SOLD}	-	260	°C	Wave soldering ¹⁾
Latch-up capability	I _{LU}	-	150	mA	²⁾ Pin voltages according to absolute maximum ratings
ESD capability HBM	V _{HBM}	-	2000	V	³⁾ Excluded pin VIN
ESD capability HBM	V _{HBM}	-	1500	V	³⁾ Pin VIN
ESD capability CDM	V _{CDM}	-	500	V	⁴⁾
Input Voltage Limit	V _{IN_DC}	-0.5	3.6	V	Voltage externally supplied to the pins REF/SC, CS, TS, PWM ⁵⁾
Voltage at pin VIN	V _{INEXT}	-	26	V	Maximum voltage that can be applied to pin VIN by an external voltage source
Maximum current into pin VIN	I _{AC}	-	10	mA	

¹⁾ According to JESD22A111 Rev A.

²⁾ Latch-up capability according to JEDEC JESD78D, T_A=85°C.

³⁾ ESD-HBM according to ANSI/ESDA/JEDEC JS-001-2012.

⁴⁾ ESD-CDM according to JESD22-C101F.

⁵⁾ Permanently applied as DC value.

¹ Absolute maximum ratings (Table 4-1) are defined as ratings which, when exceeded, may lead to destruction of the integrated circuit. For the same reason, make sure that any capacitor connected to pin VCC is discharged completely, before assembling the application circuit.

4.3 Package Characteristics

Table 4-2. Package Characteristics

Parameter	Symbol	Values		Unit	Note / Test Condition
		Min.	Max.		
Thermal resistance for PG-DSO-8-58	R_{thJA}	-	178	K/W	JEDEC 1s0p for 140 mW power dissipation
		-	164	K/W	JEDEC 1s0p for 180 mW power dissipation
		-	154	K/W	JEDEC 1s0p for 220 mW power dissipation
		-	100	K/W	JEDEC 2s2p for 140, 180, 220 mW power dissipation

4.4 Operating Conditions

Table 4-3 shows the recommended operating conditions under which the electrical characteristics shown in Section 4.5 are valid.

Table 4-3. Operating Range

Parameter	Symbol	Values		Unit	Note / Test Condition
		Min.	Max.		
Junction temperature	T_J	-40	125	°C	
Lower VCC limit	V_{VCC}	V_{UVOFF}	-	V	Device is held in reset when $V_{CC} < V_{UVOFF}$
Voltage externally supplied to VCC pin	V_{VCCEXT}	-	24	V	Maximum voltage that can be applied to the pin VCC by an external voltage source
Gate driver pin voltage	V_{GD}	-0.3	$V_{VCC}+0.3$	V	

4.5 DC Electrical Characteristics

The electrical characteristics involve the spread of values given within the specified supply voltage and junction temperature range T_J from -40°C to $+125^{\circ}\text{C}$. Typical values represent the median values related to $T_A = 25^{\circ}\text{C}$. All voltages refer to GND, and the assumed supply voltage is $V_{VCC} = 18\text{ V}$, if not specified otherwise.

The following characteristics are specified:

Table 4-4. Electrical Characteristics of the Power Supply

Parameter	Symbol	Values			Unit	Note / Test Condition
		Min.	Typ.	Max.		
VCC Externally Powered Startup						
VCC_ON_EXT threshold	V_{EXT}	7	-	11	V	
VCC_ON_EXT delay	t_{EXT}	-	-	2000	ns	Reaction time of VCC_EXT monitor ¹⁾
VCC System Turn Off						
VCC_UVOFF current	$I_{VCCUVOFF}$	5	20	40	μA	$V_{VCC} < V_{EXT}(\text{min}) - 0.3\text{ V}$
UVOFF threshold	V_{UVOFF}	-	6.0	-	V	
UVOFF threshold tolerance	Δ_{UVOFF}	-5	-	5	%	This value defines the tolerance of V_{UVOFF}
UVOFF filter constant	t_{UVOFF}	550	-	-	ns	¹⁾ 1 V overdrive
ADC Measurement of VCC						
Maximum Error for ADC measurement (8 bit result)	$TE0_{VCC}$	-	-	4.5	LSB_8	¹⁾
	$TE256_{VCC}$	-	-	8.9	LSB_8	¹⁾

¹⁾ Not tested in production test.

Table 4-5. Electrical Characteristics of Pin VIN

Parameter	Symbol	Values			Unit	Note / Test Condition
		Min.	Typ.	Max.		
Voltage at pin VIN	V_{VIN}	0	-	24	V	Maximum voltage that can be applied to the pin VIN by an external voltage source
Maximum current into pin VIN	I_{AC}	-	-	10	mA	For measurement path
Nominal current for measurement path	I_{MEAS}	0	-	1.6	mA	Current range 01 _b ²⁾
		0	-	209	μA	Current range 00 _b ²⁾
Reduced measurement range for current path	RR_{IMEAS}	4	-	80	%	Current range 01 _b ³⁾
		4	-	80	%	Current range 00 _b ³⁾
Nominal measurement path resistor value	R_{SHUNT}	-	1.49	-	k Ω	Current range 01 _b
		-	6.69	-	k Ω	Current range 00 _b
Measurement path resistor tolerance	Δ_{RSHUNT}	-20	-	20	%	Already reflected in RR_{IMEAS}
Maximum error for corrected ADC measurement (8 bit result)	$TET0_{I01}$	-	-	4.1	LSB_8	¹⁾
	$TET256_{I01}$	-	-	8.4	LSB_8	¹⁾

¹⁾ Not tested in production test.

²⁾ Defined by the parameter $V_{in_current_range}$ (See [Table 3-8](#)).

³⁾ Operational values.

Table 4-6. Electrical Characteristics of Pin REF/SC

Parameter	Symbol	Values			Unit	Note / Test Condition
		Min.	Typ.	Max.		
Digital Input Stage Characteristics						
Input capacitance	C_{INPUT}	-	-	10	pF	¹⁾
Input low voltage	V_{IL}	-	-	1.0	V	
Input high voltage	V_{IH}	2.0	-	-	V	
Input leakage current, no pull device	I_{LK}	-10	-	10	μA	$V_{\text{REF/SC}} = 0 \text{ V} / 3 \text{ V}$
		-1	-	1	μA	¹⁾ $T_{\text{J}} = 85^{\circ}\text{C}$ $V_{\text{REF/SC}} = 0 \text{ V} / 3 \text{ V}$
Input low current with active weak pull-up WPU	$-I_{\text{LPU}}$	30	-	90	μA	Measured at max. V_{IL}
Digital Output Stage Characteristics						
Output low voltage	V_{OL}	-	-	0.8	V	$I_{\text{OL}} = 2 \text{ mA}$
Output high voltage	V_{OH}	2.2	-	-	V	$I_{\text{OH}} = -2 \text{ mA}$
Output sink current	I_{OL}	-	-	2	mA	
Output source current	$-I_{\text{OH}}$	-	-	2	mA	
Output rise time (0 → 1)	t_{RISE}	-	-	25	ns	20 pF load, push/pull output ¹⁾
Output fall time (1 → 0)	t_{FALL}	-	-	25	ns	20 pF load, push/pull or open-drain output ¹⁾
Maximum output switching frequency	f_{SWITCH}	15	-	-	MHz	¹⁾
Analog Buffer and ADC channel Characteristics						
Nominal range	V_{MFIO}	0	-	V_{REF}	V	
Reduced operating range	RR_{VMFIO}	4	-	96	%	²⁾
Maximum error for measurement (8 bit result)	$TE0_{\text{VMF0}}$	-	-	3.3	LSB_8	¹⁾
	$TE256_{\text{VMF0}}$	-	-	5.6	LSB_8	¹⁾
Pull-Up Resistor Characteristics						
Pull-up resistor value	R_{PU}	-	30	-	k Ω	
Pull-up resistor tolerance	ΔR_{PU}	-20	-	20	%	Overall tolerance

¹⁾ Not tested in production test.

²⁾ Operational values.

Electrical Characteristics

Table 4-7. Electrical Characteristics of Pin CS

Parameter	Symbol	Values			Unit	Note / Test Condition
		Min.	Typ.	Max.		
Input Clamping Characteristics						
Input voltage negative clamping level	$-V_{INPCLN}$	600	1000	1500	mV	Analog clamp structure activated
OCP2 Comparator Characteristics						
OCP2 threshold voltage, derived from V_{VDDP} , given values assuming $V_{VDDP} = 3.3\text{ V}$	V_{OCP2}	-	0.6	-	V	Current sense range $11_b^{1)}$
		-	0.8	-	V	Current sense range $10_b^{1)}$
Threshold voltage tolerance	ΔV_{OCP2}	-5	-	5	%	Voltage divider tolerance
Delay from V_{CS} crossing V_{CSOCP2} to begin of GD0 turn-off ($I_{GD0} > 2\text{ mA}$)	$t_{CSGD0OCP2}$	125	155	190	ns	²⁾ $dV_{CS}/dt = 100\text{ V}/\mu\text{s}$ $f_{MCLK} = 66\text{ MHz}$ GD0 driven by QR_GATE FIL_OCP2.STABLE = 3
OCP1 Comparator Characteristics						
Operating range	V_{OCP1}	0	-	$V_{REF}/6$	V	Current sense range $11_b^{1)}$
		0	-	$V_{REF}/4$	V	Current sense range $10_b^{1)}$
OCP1 threshold voltage step width	V_{OCP1ST}	-	1.581	-	mV	Current sense range $11_b^{1)}$
		-	2.371	-	mV	Current sense range $10_b^{1)}$
OCP1 threshold at full scale setting ($CS_OCP1LVL=FF_H$)	V_{OCP1FS}	392	403	430	mV	Current sense range $11_b^{1)}$
		583	605	627	mV	Current sense range $10_b^{1)}$
OCP1 integral nonlinearity	$V_{OCP1INL}$	-1.9	-	1.9	LSB ₈	Current sense range $11_b^{1)}$
		-2.9	-	2.9	LSB ₈	Current sense range $10_b^{1)}$
Delay from V_{CS} crossing V_{CSOCP1} to begin of GD0 turn-off ($I_{GD0} > 2\text{ mA}$)	$t_{CSGD0OCP1}$	180	260	345	ns	²⁾ $dV_{CS}/dt = 53\text{ mV}/\mu\text{s}$ $f_{MCLK} = 66\text{ MHz}$ GD0 driven by QR_GATE
		120	185	250	ns	²⁾ $dV_{CS}/dt = 272\text{ mV}/\mu\text{s}$ $f_{MCLK} = 66\text{ MHz}$ GD0 driven by QR_GATE
		100	130	165	ns	²⁾ $dV_{CS}/dt = 100\text{ V}/\mu\text{s}$ $f_{MCLK} = 66\text{ MHz}$ GD0 driven by QR_GATE
OCP1 comparator input single pulse width filter	t_{OCP1PW}	60	-	95	ns	Shorter pulses than min. are suppressed, longer pulses than max. are passed ²⁾
Sample & Hold Characteristics						
Nominal S&H operating range	V_{CSH}	0	-	$V_{REF}/6$	V	Current sense range $11_b^{1)}$
		0	-	$V_{REF}/4$	V	Current sense range $10_b^{1)}$
Reduced S&H operating range	RRCVSH	4	-	90	%	³⁾
S&H settling time for ADC sampling	t_{CSHSTC}	-	-	300	ns	STC = 5

¹⁾ Defined by the parameter Current_sense_OCP1 (See Table 3-8).

²⁾ Not tested in production test.

³⁾ Operational values.

The absolute error of the OCP1 comparator is limited according to

$$|V_{OCP1} - V_{OCP1Nom}| \leq |V_{OCP1FS} - V_{OCP1ST} \cdot 255| + |V_{OCP1INL}|$$

Electrical Characteristics

If the voltage at pin CS $V_{CS}(t)$ is a linear rising signal starting below the OCP1 threshold, the delay between the time when the voltage crosses the threshold and the CS comparator output rising edge $t_{CSGD0OCP1}$ is a function of the slope. Two representative slopes are specified to characterize this dependency.

Table 4-8. Electrical Characteristics of Gate Driver Pin GD0

Parameter	Symbol	Values			Unit	Note / Test Condition
		Min.	Typ.	Max.		
APD low voltage (active pull down while device is not powered or gate driver is not enabled)	V_{APD}	-	-	1.6	V	$I_{GD} = 5 \text{ mA}$ ⁴⁾
R_{PPD} value	R_{PPD}	-	600	-	k Ω	Permanent pull-down resistor inside gate driver
R_{PPD} tolerance	ΔR_{PPD}	-25	-	25	%	Permanent pull-down resistor inside gate driver
Driver Output low impedance	R_{GDL}	-	-	6.5	Ω	Driver stage enabled and at low state
Output voltage at high state	V_{GDH}	4.5	-	15	V	Programming options ¹⁾
Output voltage tolerance	ΔV_{GDH}	-5	-	5	%	Tolerance of programming options if $V_{GDH} > 10 \text{ V}$
		-0.5	-	0.5	V	Tolerance of programming options if $V_{GDH} < 10 \text{ V}$
Rail-to-rail output high voltage	V_{GDHRR}	$V_{VCC} - 0.5$	-	V_{VCC}	V	If $V_{VCC} < \text{programmed } V_{GDH}$ and output at high state
Nominal output high current ²⁾	$-I_{GDH}$	30	-	118	mA	Programming options ³⁾ , $C_{LOAD} = 2 \text{ nF}$
Output high current tolerance	ΔI_{GDH}	-20	-	20	%	
Output high current settling time	t_{IGDHST}	-	-	40	ns	Start of high state to output current stable ⁴⁾
Discharge current	I_{GDDIS}	500	-	-	mA	$V_{GD} = 4 \text{ V}$ and driver at low state ⁴⁾

¹⁾ Defined by the parameter GD_voltage (See [Table 3-8](#)).

²⁾ If open drain mode is selected, then $-I_{GDH} = 0$.

³⁾ Defined by the parameter GD_current (See [Table 3-8](#)).

⁴⁾ Not tested in production test.

Table 4-9. Electrical Characteristics of Digital Input Pin PWM

Parameter	Symbol	Values			Unit	Note / Test Condition
		Min.	Typ.	Max.		
Input capacitance	C_{INPUT}	-	-	25	pF	¹⁾
Input low voltage	V_{IL}	-	-	1.0	V	
Input high voltage	V_{IH}	2.1	-	-	V	
Input low current with active weak pull-up WPU	$-I_{LPU}$	30	-	90	μA	Measured at max. V_{IL}
Input high current with active weak pull-down WPD	I_{HPD}	110	-	300	μA	Measured at min. V_{IH}
Maximum input frequency	f_{INPUT}	15	-	-	MHz	

¹⁾ Not tested in production test.

Table 4-10. Electrical Characteristics of Pin TS

Parameter	Symbol	Values			Unit	Note / Test Condition
		Min.	Typ.	Max.		
Nominal S&H input voltage range	V_{ZSH}	0	-	$\frac{2}{3} * V_{REF}$	V	
Reduced S&H input voltage range	RR_{ZVSH}	4	-	95	%	²⁾
Maximum Error for ADC measurement (8 bit result)	$TE0_{ZVS0}$	-	-	6.3	LSB_8	¹⁾
	$TE256_{ZVS0}$	-	-	6.3	LSB_8	¹⁾
Maximum Error for corrected ADC measurement (8 bit result)	$TET0_{ZVS0}$	-	-	2.8	LSB_8	¹⁾
	$TET256_{ZVS0}$	-	-	4.6	LSB_8	¹⁾
S&H settling time for ADC sample	t_{ZSHSTC}	-	-	300	ns	STC = 5
Voltage Drop of sampled input voltage if ADC measurement is started 100 μ s after end of sampling phase	V_{ZDROP}	0	-	3	LSB_8	$T_J = 85^\circ C$ ¹⁾
		0	5	-	LSB_8	$T_J = 125^\circ C$ ¹⁾

¹⁾ Not tested in production test.

²⁾ Operational values.

Table 4-11. Electrical Characteristics of the A/D Converter ¹⁾

Parameter	Symbol	Values			Unit	Note / Test Condition
		Min.	Typ.	Max.		
Usable sample time	t_S	24 * t_{MCLK}	-	64 * t_{MCLK}	ns	Selected by STC between 5 and 15
Conversion time for STC = 5	$t_{C(STC=5)}$	-	57 * t_{MCLK}	-	ns	²⁾
Conversion time for STC = 15	$t_{C(STC=15)}$	-	97 * t_{MCLK}	-	ns	²⁾
Integral non-linearity	INL	-	-	1	LSB_8	³⁾
Differential non-linearity	DNL	-	-	0.8	LSB_8	

¹⁾ The sample time t_S of the A/D converter is given by $t_S = (STC+1) * 4 * t_{MCLK}$. The conversion time t_C (including sample time) is given by $t_C = 33 * t_{MCLK} + (STC+1) * 4 * t_{MCLK}$.

²⁾ Any conversion needs exact these numbers of clock cycles by design.

³⁾ ADC capability measured via channel MFIO without errors due to switching of neighboring pins, measured with STC = 5.

Table 4-12. Electrical Characteristics of the Reference Voltage V_{REF}

Parameter	Symbol	Values			Unit	Note / Test Condition
		Min.	Typ.	Max.		
Reference voltage	V_{REF}	-	2.428	-	V	
VREF tolerance	ΔV_{REF}	-1	-	1	%	Trimmed, $T_A = 25^\circ C$
VREF tolerance	ΔV_{REF}	-2	-	2	%	Trimmed, over full temperature range and aging ¹⁾

¹⁾ Not tested in production test.

Table 4-13. Electrical Characteristics of the Clock Oscillators

Parameter	Symbol	Values			Unit	Note / Test Condition
		Min.	Typ.	Max.		
Master clock oscillation period	t_{MCLK}	20.0	20.9	22.0	ns	Referred as 50 MHz f_{MCLK}

Table 4-14. Electrical Characteristics of the internal Temperature Sensor

Parameter	Symbol	Values			Unit	Note / Test Condition
		Min.	Typ.	Max.		
Temperature sensor output voltage operating range	$V_{ADCTEMP}$	0	-	190/255 * V_{REF}	V	$V_{ADCTEMP} = V_{REF}/255 * (40 + \text{temperature in } ^\circ\text{C})$
Temperature sensor tolerance	Δ_{TEMP}	-8	-	8	K	Incl. ADC conversion accuracy at 4σ ¹⁾

¹⁾ Not tested in production test.

Table 4-15. Electrical Characteristics of the OTP Programming

Parameter	Symbol	Values			Unit	Note / Test Condition
		Min.	Typ.	Max.		
OTP programming voltage at the VCC pin	V_{PP}	7.35	7.5	7.65	V	^{1) 2)}
OTP programming current	I_{PP}	-	1.6	-	mA	Programming of 4 bit in parallel ²⁾

¹⁾ Operational values.

²⁾ Not tested in production test.

Edition 2015-04-08

**Published by
Infineon Technologies AG
81726 Munich, Germany**

**© 2015 Infineon Technologies AG
All Rights Reserved.**

Legal Disclaimer

The information given in this document shall in no event be regarded as a guarantee of conditions or characteristics. With respect to any examples or hints given herein, any typical values stated herein and/or any information regarding the application of the device, Infineon Technologies hereby disclaims any and all warranties and liabilities of any kind, including without limitation, warranties of non-infringement of intellectual property rights of any third party.

Information

For further information on technology, delivery terms and conditions and prices, please contact the nearest Infineon Technologies Office (www.infineon.com).

Warnings

Due to technical requirements, components may contain dangerous substances. For information on the types in question, please contact the nearest Infineon Technologies Office.



Infineon Technologies components may be used in life-support devices or systems only with the express written approval of Infineon Technologies, if a failure of such components can reasonably be expected to cause the failure of that life-support device or system or to affect the safety or effectiveness of that device or system. Life support devices or systems are intended to be implanted in the human body or to support and/or maintain and sustain and/or protect human life. If they fail, it is reasonable to assume that the health of the user or other persons may be endangered.

www.infineon.com





Published by Infineon Technologies AG

Looking for pricing, stock, or lifecycle information?

Click below to explore more details on WIN SOURCE:

-  [View ILD2111XUMA2 on WIN SOURCE](#)
-  [Infineon Technologies Information](#)

Optimize Your Supply Chain with WIN SOURCE Solutions

-  Global Sourcing Solution
-  Obsolete Management
-  Cost Control Management
-  Shortage Management
-  Alternative Solution
-  Excess Inventory Management