



**THE DATASHEET OF  
TPD8S009DSMR**



## TPD8S009 8-Channel ESD Protection for DisplayPort and HDMI

### 1 Features

- IEC 61000-4-2 Level 4 ESD Protection
  - $\pm 8$ -kV Contact Discharge
- IEC 61000-4-5 Surge Protection
  - 2.5 A (8 / 20  $\mu$ s)
- I/O Capacitance: 0.8 pF (Typical)
- Low Leakage Current: 10 nA (Typical)
- Supports High-Speed Differential Data Rates (3-dB Bandwidth > 4 GHz)
- $I_{off}$  Feature
- Industrial Temperature Range:  $-40^{\circ}\text{C}$  to  $+85^{\circ}\text{C}$
- Easy Straight-Through Routing Package for HDMI and DisplayPort Connectors

### 2 Applications

- End Equipment
  - Set-Top Boxes
  - Laptops and Desktops
  - Projectors
  - Video Surveillance
- Interfaces
  - DisplayPort 1.1
  - HDMI 1.4
  - DVI

### 3 Description

The TPD8S009 device is an eight-channel TVS diode array for ESD protection. The TPD8S009 is rated to dissipate contact ESD strikes at the maximum level specified in the IEC 61000-4-2 international standard (Level 4), with  $\pm 8$ -kV contact discharge ESD protection. The low capacitance (0.8 pF) of this device, coupled with the excellent matching between differential signal pairs enables this device to provide transient voltage suppression circuit protection for high-speed differential data rates (3-dB bandwidth > 4 GHz).

The TPD8S009 is offered in a 8-pin SON package. This package offers easy design and layout, as the package matches exactly with the HDMI and DisplayPort high-speed pinout.

#### Device Information<sup>(1)</sup>

PART NUMBER	PACKAGE	BODY SIZE (NOM)
TPD8S009	SON (15)	2.50 mm x 6.50 mm

(1) For all available packages, see the orderable addendum at the end of the data sheet.

#### Simplified Internal Schematic

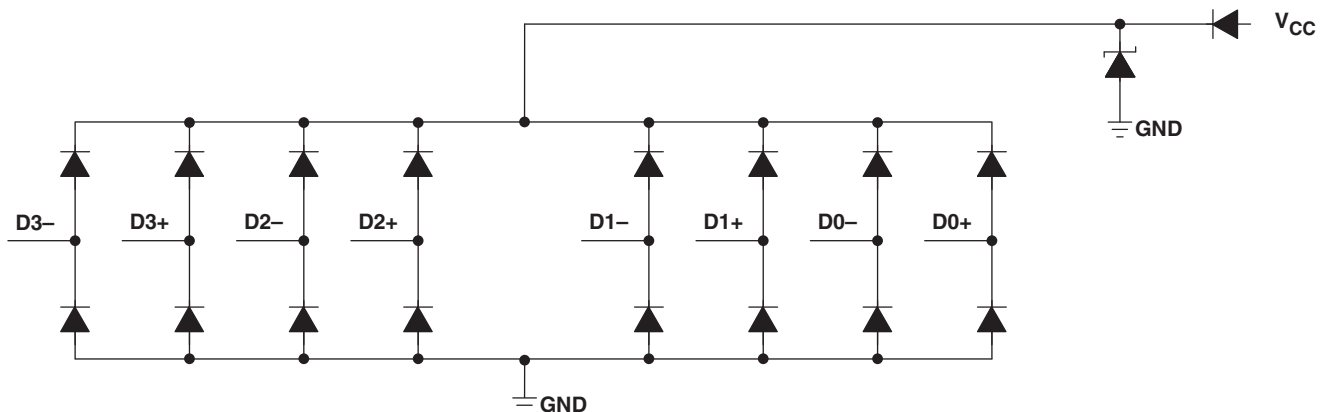

## Table of Contents

<b>1 Features</b> .....	<b>1</b>	7.3 Feature Description .....	<b>6</b>
<b>2 Applications</b> .....	<b>1</b>	7.4 Device Functional Modes .....	<b>7</b>
<b>3 Description</b> .....	<b>1</b>	<b>8 Application and Implementation</b> .....	<b>8</b>
<b>4 Revision History</b> .....	<b>2</b>	8.1 Application Information .....	<b>8</b>
<b>5 Pin Configuration and Functions</b> .....	<b>3</b>	8.2 Typical Application .....	<b>8</b>
<b>6 Specifications</b> .....	<b>4</b>	<b>9 Power Supply Recommendations</b> .....	<b>10</b>
6.1 Absolute Maximum Ratings .....	<b>4</b>	<b>10 Layout</b> .....	<b>10</b>
6.2 ESD Ratings .....	<b>4</b>	10.1 Layout Guidelines .....	<b>10</b>
6.3 Recommended Operating Conditions .....	<b>4</b>	10.2 Layout Example .....	<b>10</b>
6.4 Thermal Information .....	<b>4</b>	<b>11 Device and Documentation Support</b> .....	<b>11</b>
6.5 Electrical Characteristics .....	<b>5</b>	11.1 Community Resources .....	<b>11</b>
6.6 Typical Characteristics .....	<b>5</b>	11.2 Trademarks .....	<b>11</b>
<b>7 Detailed Description</b> .....	<b>6</b>	11.3 Electrostatic Discharge Caution .....	<b>11</b>
7.1 Overview .....	<b>6</b>	11.4 Glossary .....	<b>11</b>
7.2 Functional Block Diagram .....	<b>6</b>	<b>12 Mechanical, Packaging, and Orderable Information</b> .....	<b>11</b>

## 4 Revision History

NOTE: Page numbers for previous revisions may differ from page numbers in the current version.

<b>Changes from Original (July 2008) to Revision A</b>	<b>Page</b>
• Added <i>ESD Ratings</i> table, <i>Feature Description</i> section, <i>Device Functional Modes</i> , <i>Application and Implementation</i> section, <i>Power Supply Recommendations</i> section, <i>Layout</i> section, <i>Device and Documentation Support</i> section, and <i>Mechanical, Packaging, and Orderable Information</i> section. ....	<b>1</b>
• Deleted <i>Ordering Information</i> table .....	<b>1</b>
• Removed Lead temperature from <i>Absolute Maximum Ratings</i> .....	<b>4</b>

## 5 Pin Configuration and Functions

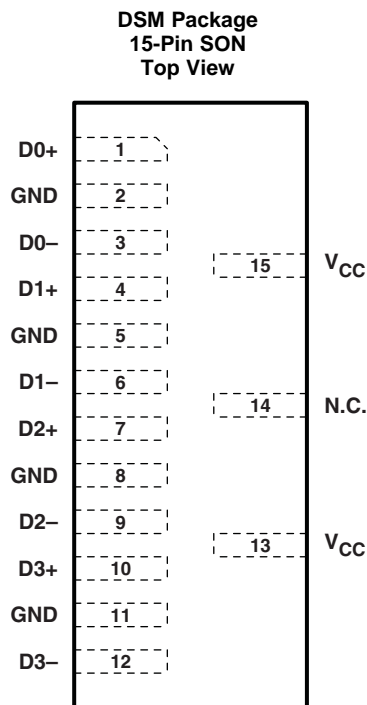

N.C. – Not internally connected

### Pin Functions

PIN		TYPE	DESCRIPTION
NO.	NAME		
1	D0+	ESD port	High-speed ESD clamp provides ESD protection to the high-speed display port/HDMI differential data lines.
3	D0–		
4	D1+		
6	D1–		
7	D2+		
9	D2–		
10	D3+		
12	D3–		
2	GND	GND	Ground
5			
8			
11			
14	N.C.	No connect	No internal signal connection
13	V <sub>CC</sub>	Supply	I/O supply
15			

## 6 Specifications

### 6.1 Absolute Maximum Ratings

over operating free-air temperature range (unless otherwise noted)<sup>(1)</sup>

		MIN	MAX	UNIT
V <sub>CC</sub>	Supply voltage	-0.3	6	V
V <sub>IO</sub>	IO signal voltage	0	V <sub>CC</sub>	V
T <sub>A</sub>	Characterized free-air operating temperature	-40	85	°C
P <sub>PP</sub>	Peak pulse power (t <sub>p</sub> = 8/20 μs)		25	W
I <sub>PP</sub>	Peak pulse current (t <sub>p</sub> = 8/20 μs)		2.5	A
T <sub>stg</sub>	Storage temperature	-65	125	°C

- (1) Stresses beyond those listed under *Absolute Maximum Ratings* may cause permanent damage to the device. These are stress ratings only, which do not imply functional operation of the device at these or any other conditions beyond those indicated under *Recommended Operating Conditions*. Exposure to absolute-maximum-rated conditions for extended periods may affect device reliability.

### 6.2 ESD Ratings

		VALUE	UNIT
V <sub>(ESD)</sub>	Electrostatic discharge	Human-body model (HBM), per ANSI/ESDA/JEDEC JS-001 <sup>(1)</sup>	V
		Charged-device model (CDM), per JEDEC specification JESD22-C101 <sup>(2)</sup>	
		IEC 61000-4-2 Contact Discharge	
		IEC 61000-4-2 Air-Gap Discharge	

- (1) JEDEC document JEP155 states that 500-V HBM allows safe manufacturing with a standard ESD control process.

- (2) JEDEC document JEP157 states that 250-V CDM allows safe manufacturing with a standard ESD control process.

### 6.3 Recommended Operating Conditions

over operating free-air temperature range (unless otherwise noted)

		MIN	MAX	UNIT
V <sub>IO</sub>	Input pin voltage	0	V <sub>CC</sub>	V
T <sub>A</sub>	Operating free-air temperature	-40	85	°C

### 6.4 Thermal Information

THERMAL METRIC <sup>(1)</sup>	TPD8S009	UNIT	
	DSM (SON)		
	15 PINS		
R <sub>θJA</sub>	Junction-to-ambient thermal resistance	405.4	°C/W
R <sub>θJC(top)</sub>	Junction-to-case (top) thermal resistance	35.4	°C/W
R <sub>θJB</sub>	Junction-to-board thermal resistance	284.3	°C/W
Ψ <sub>JT</sub>	Junction-to-top characterization parameter	49.2	°C/W
Ψ <sub>JB</sub>	Junction-to-board characterization parameter	284.3	°C/W
R <sub>θJC(bot)</sub>	Junction-to-case (bottom) thermal resistance	n/a	°C/W

- (1) For more information about traditional and new thermal metrics, see the *Semiconductor and IC Package Thermal Metrics* application report, [SPRA953](#).

### 6.5 Electrical Characteristics

over operating free-air temperature range (unless otherwise noted)

PARAMETER		TEST CONDITIONS		MIN	TYP	MAX	UNIT
$V_{RWM}$	Reverse standoff voltage	Any IO pin to ground				5.5	V
$V_{BR}$	Breakdown voltage	$I_{IO} = 1 \text{ mA}$	Any IO pin to ground	9			V
$I_{IO}$	IO port current	$V_{IO} = 3.3 \text{ V}, V_{CC} = 5 \text{ V}$	Any IO pin		0.01	0.1	$\mu\text{A}$
$I_{off}$	Current from IO port to supply pins	$V_{IO} = 3.3 \text{ V}, V_{CC} = 5 \text{ V}$	Any IO pin		0.01	0.1	$\mu\text{A}$
$V_D$	Diode forward voltage	$I_{IO} = 8 \text{ mA}$	Lower clamp diode	0.6	0.8	0.95	V
$R_{DYN}$	Dynamic resistance	$I = 1 \text{ A}$	Any IO pin		1.1		$\Omega$
$C_{IO}$	IO capacitance	$V_{CC} = 5 \text{ V}, V_{IO} = 2.5 \text{ V}$	Any IO pin		0.8		pF
$I_{CC}$	Operating supply current	$V_{IO} = \text{Open}, V_{CC} = 5 \text{ V}$	$V_{CC}$ pin		0.1	1	$\mu\text{A}$

### 6.6 Typical Characteristics

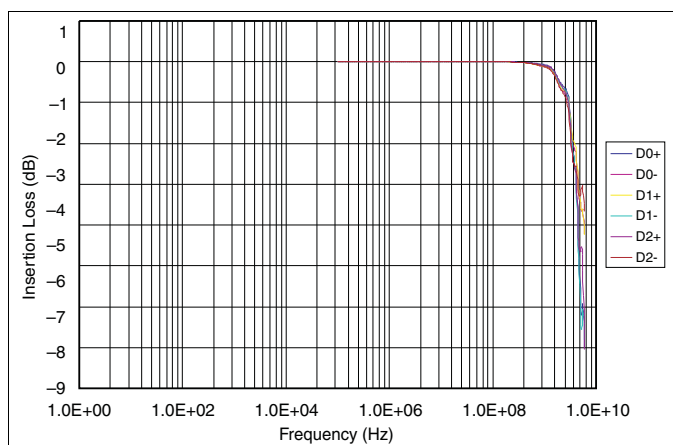

**Figure 1. Insertion Loss vs Frequency**

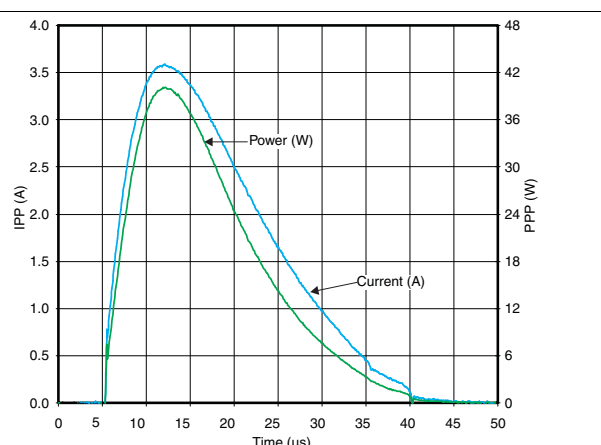

**Figure 2. Peak Pulse Waveforms**

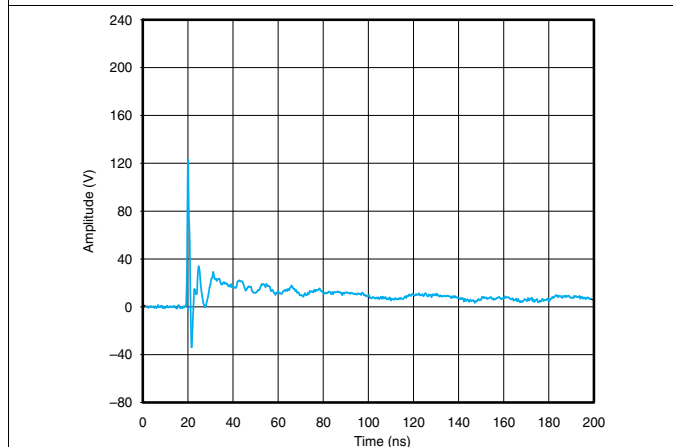

**Figure 3. IEC Clamping Waveforms (8-kV Contact)**

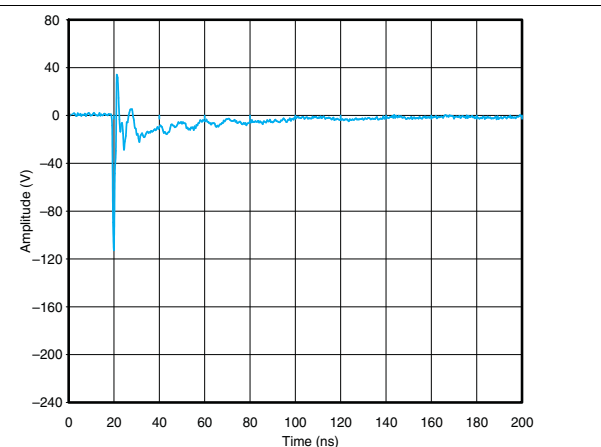

**Figure 4. Figure 3. IEC Clamping Waveforms (-8-kV Contact)**

## 7 Detailed Description

### 7.1 Overview

The TPD8S009 is an eight-channel TVS diode array for ESD protection. TPD8S009 is rated to dissipate contact ESD strikes at the maximum level specified in the IEC 61000-4-2 international standard (Level 4), with  $\pm 8$ -kV contact discharge ESD protection. The low capacitance (0.8 pF) of this device, coupled with the excellent matching between differential signal pairs enables this device to provide transient voltage suppression circuit protection for high-speed differential data rates (3-dB bandwidth > 4 GHz).

The TPD8S009 offers an optional  $V_{CC}$  supply pin which can be connected to system supply plane. There is a blocking diode at the  $V_{CC}$  pin to enable the  $I_{off}$  feature for the TPD8S009. The TPD8S009 can handle live signal at the signal pins when the  $V_{CC}$  pin is connected to 0 V. The  $V_{CC}$  pin allows all the internal circuit nodes of the TPD8S009 to be at known potential during start-up time. However, connecting the optional  $V_{CC}$  pin to board supply plane doesn't affect the system level ESD performance of the TPD8S009.

### 7.2 Functional Block Diagram

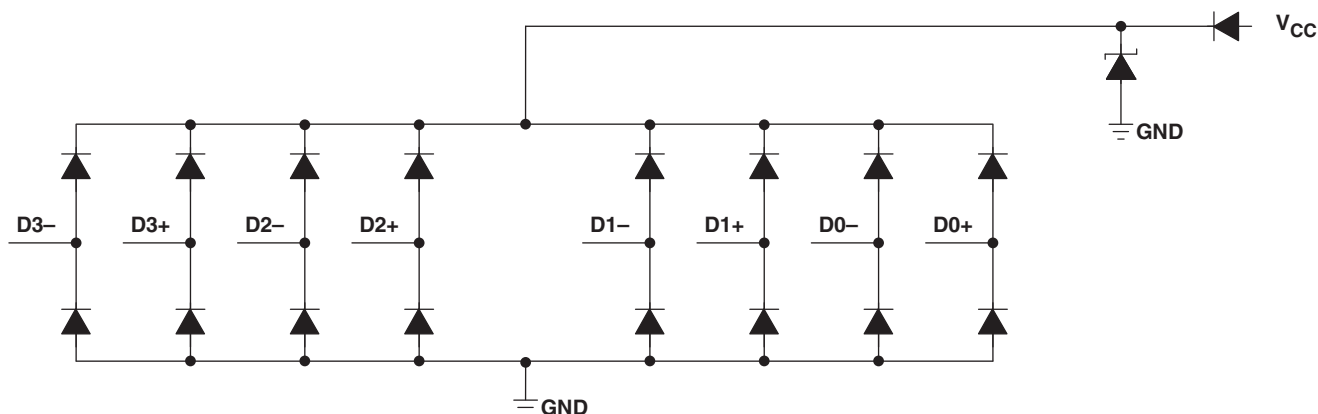

### 7.3 Feature Description

#### 7.3.1 IEC 61000-4-2 ESD Protection

The I/O pins can withstand ESD events up to  $\pm 8$ -kV contact and  $\pm 9$ -kV air. An ESD and surge clamp diverts the current to ground.

#### 7.3.2 IEC 61000-4-5 Surge Protection

The I/O pins can withstand surge events up to 2.5 A and 25 W (8/20- $\mu$ s waveform). An ESD and surge clamp diverts this current to ground.

#### 7.3.3 I/O Capacitance

The capacitance between each I/O pin to ground is 0.8 pF (typical). This device can support data rates up to 3.4 Gbps.

#### 7.3.4 Low Leakage Current

The I/O pins feature a low leakage current of 10 nA (typical) with an IO bias of 3.3 V and  $V_{CC}$  bias of 5 V.

#### 7.3.5 Supports High-Speed Differential Data Rates

The I/O pins low capacitance of 0.8 pF (typical) gives them a typical  $-3$ -dB bandwidth > 4 GHz. This allows the TPD8S009 to protect interfaces with high-speed signals like HDMI 1.4.

## Feature Description (continued)

### 7.3.6 I<sub>off</sub> Feature

The TPD8S009 offers an optional V<sub>CC</sub> supply pin which can be connected to system supply plane. There is a blocking diode at the V<sub>CC</sub> pin which makes it so the TPD4S009 can handle live signal at the D+, D– pins when the V<sub>CC</sub> pin is connected to 0 V. This is the I<sub>off</sub> feature, which is crucial for HDMI, as a live signal can be put on the IO pins when the system is powered off.

### 7.3.7 Industrial Temperature Range

This device features an industrial operating range of –40°C to +85°C.

### 7.3.8 Easy Straight Through Routing

The layout of this device makes it simple and easy to add protection to an existing layout. The package offers flow-through routing, requiring minimal modification to an existing layout. Flow-through routing also allows the PCB designer to optimize the signal integrity of any high-speed signals being protected.

## 7.4 Device Functional Modes

TPD8S009 is a passive-integrated circuit that activates whenever voltages above V<sub>BR</sub> or below the lower diodes V<sub>forward</sub> (–0.6 V) are present upon the circuit being protected. During ESD events, voltages as high as ±9 kV can be directed to ground and V<sub>CC</sub> through the internal diode network. Once the voltages on the protected lines fall below the trigger voltage of the TPD8S009 (usually within 10's of nano-seconds) the device reverts back to a high-impedance state.

## 8 Application and Implementation

### NOTE

Information in the following applications sections is not part of the TI component specification, and TI does not warrant its accuracy or completeness. TI's customers are responsible for determining suitability of components for their purposes. Customers should validate and test their design implementation to confirm system functionality.

### 8.1 Application Information

The TPD8S009 can provide system-level ESD protection to the high-speed differential lines of the HDMI or display ports. The flow-through package offers flexibility for board routing with traces up to 15-mm wide. [Figure 5](#) shows the board-layout scheme for the four differential pair lines. The special pin configuration of the TPD8S009 matches the HDMI or DisplayPort pin assignments. It allows the differential signal pairs to couple together after they touch the ESD ports (pins 1–3, 4–6, 7–9, and 10–12) of the TPD8S009.

The TPD4E001 is recommended for ESD protection of slow-speed control lines.

### 8.2 Typical Application

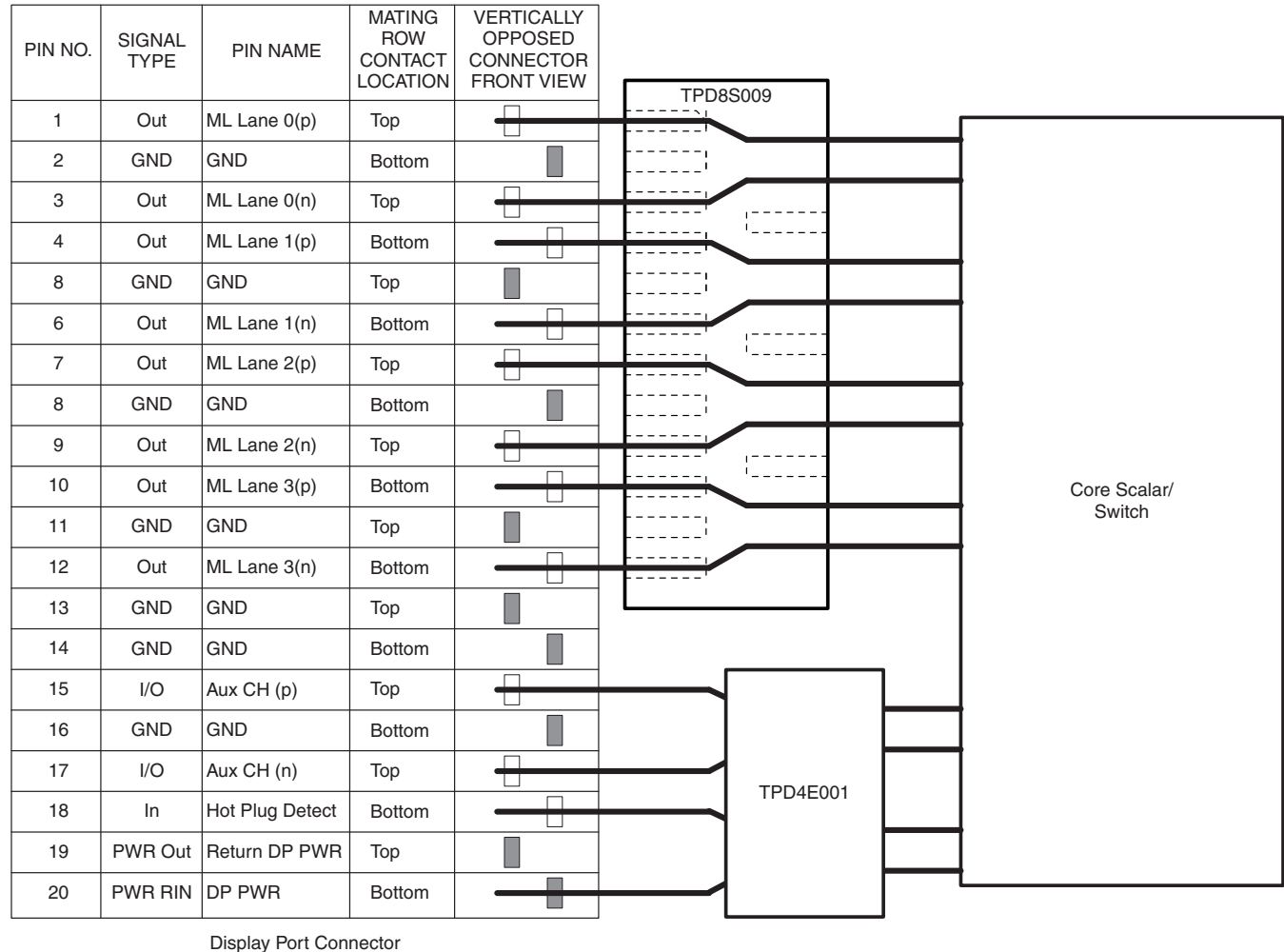

TPD8S009 and TPD4E001 provide complete ESD protection for display or HDMI interface

**Figure 5. Typical Application**

## Typical Application (continued)

### 8.2.1 Design Requirements

For this design example, one TPD8S009 devices, and one TPD4E001 are being used in an HDMI 1.4 application. This provides a complete port protection scheme.

Given the HDMI 1.4 application, the following parameters are shown in [Table 1](#).

**Table 1. Design Parameters**

DESIGN PARAMETER	VALUE
Signal range on high-speed TMDS pins	0 V to 3.6 V
Operating Frequency	1.7 GHz

### 8.2.2 Detailed Design Procedure

To begin the design process, some parameters must be decided upon; the designer must know the following:

- Signal range on all the protected lines
- Operating frequency

#### 8.2.2.1 Signal Range on High Speed TMDS Pins

TPD8S009 has 8 identical protection channels for signal lines. The symmetry of the device provides flexibility when selecting which of the 8 I/O channels protect which signal lines. The package is also designed to easily lay out on an HDMI connector, eliminating any tricky routing issues. Any I/O supports a signal range of 0 to 5.5 V. Therefore, this device supports the HDMI 1.4 signal swing.

#### 8.2.2.2 Bandwidth on High-Speed TMDS Pins

Each pin of the TPD8S009 has a typical  $-3$ -dB bandwidth of 4GHz. Therefore, this device can handle HDMI 1.4 data rate of 3.4 Gbps with operating frequency of 1.7 GHz.

### 8.2.3 Application Curves

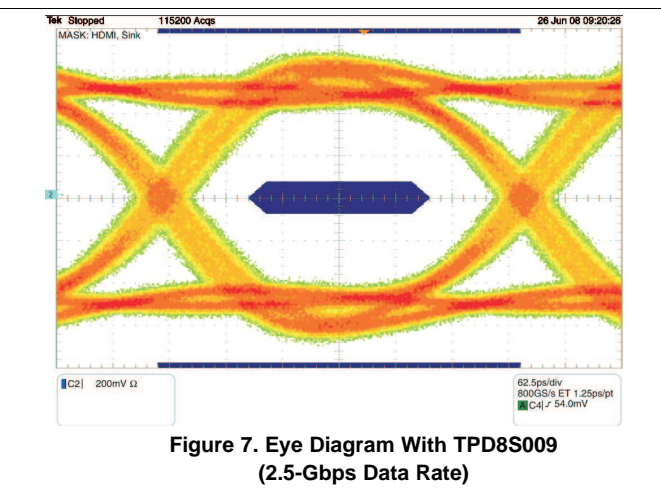
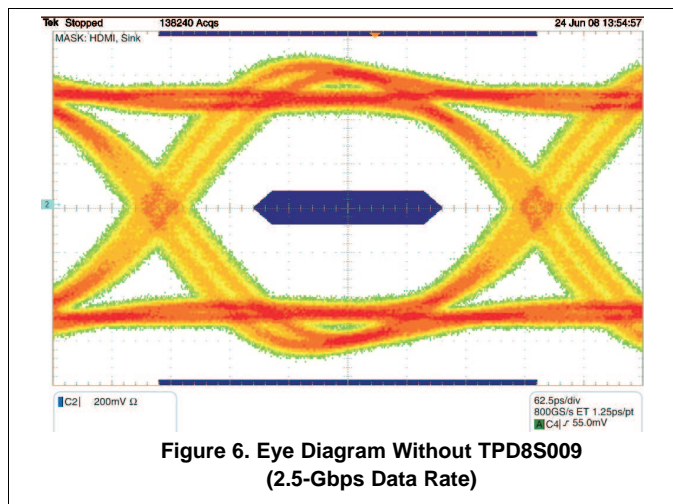

## 9 Power Supply Recommendations

This device is a passive ESD protection device so there is no need to power it. Take care to make sure that the maximum voltage specifications for each pin are not violated.

## 10 Layout

### 10.1 Layout Guidelines

- The optimum placement is as close to the connector as possible.
  - EMI during an ESD event can couple from the trace being struck to other nearby unprotected traces, resulting in early system failures.
  - The PCB designer must minimize the possibility of EMI coupling by keeping any unprotected traces away from the protected traces which are between the TVS and the connector.
- Route the protected traces as straight as possible.
- Eliminate any sharp corners on the protected traces between the TVS and the connector by using rounded corners with the largest radii possible.
  - Electric fields tend to build up on corners, increasing EMI coupling.

### 10.2 Layout Example

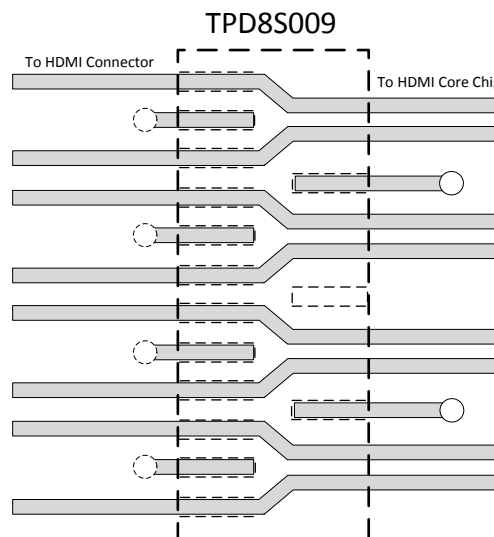

### Legend

- VIA to 5V Plane
- VIA to GND Plane

**Figure 8. Typical Layout for HDMI Connector**

## 11 Device and Documentation Support

### 11.1 Community Resources

The following links connect to TI community resources. Linked contents are provided "AS IS" by the respective contributors. They do not constitute TI specifications and do not necessarily reflect TI's views; see TI's [Terms of Use](#).

**TI E2E™ Online Community** *TI's Engineer-to-Engineer (E2E) Community*. Created to foster collaboration among engineers. At [e2e.ti.com](http://e2e.ti.com), you can ask questions, share knowledge, explore ideas and help solve problems with fellow engineers.

**Design Support** *TI's Design Support* Quickly find helpful E2E forums along with design support tools and contact information for technical support.

### 11.2 Trademarks

E2E is a trademark of Texas Instruments.  
All other trademarks are the property of their respective owners.

### 11.3 Electrostatic Discharge Caution



These devices have limited built-in ESD protection. The leads should be shorted together or the device placed in conductive foam during storage or handling to prevent electrostatic damage to the MOS gates.

### 11.4 Glossary

[SLYZ022](#) — *TI Glossary*.

This glossary lists and explains terms, acronyms, and definitions.

## 12 Mechanical, Packaging, and Orderable Information

The following pages include mechanical, packaging, and orderable information. This information is the most current data available for the designated devices. This data is subject to change without notice and revision of this document. For browser-based versions of this data sheet, refer to the left-hand navigation.

**PACKAGING INFORMATION**

Orderable Device	Status (1)	Package Type	Package Drawing	Pins	Package Qty	Eco Plan (2)	Lead/Ball Finish (6)	MSL Peak Temp (3)	Op Temp (°C)	Device Marking (4/5)	Samples
TPD8S009DSMR	ACTIVE	SON	DSM	15	3000	Green (RoHS & no Sb/Br)	CU NIPDAUAG	Level-1-260C-UNLIM	-40 to 85	PK009	Samples

(1) The marketing status values are defined as follows:

**ACTIVE:** Product device recommended for new designs.

**LIFEBUY:** TI has announced that the device will be discontinued, and a lifetime-buy period is in effect.

**NRND:** Not recommended for new designs. Device is in production to support existing customers, but TI does not recommend using this part in a new design.

**PREVIEW:** Device has been announced but is not in production. Samples may or may not be available.

**OBSOLETE:** TI has discontinued the production of the device.

(2) Eco Plan - The planned eco-friendly classification: Pb-Free (RoHS), Pb-Free (RoHS Exempt), or Green (RoHS & no Sb/Br) - please check <http://www.ti.com/productcontent> for the latest availability information and additional product content details.

**TBD:** The Pb-Free/Green conversion plan has not been defined.

**Pb-Free (RoHS):** TI's terms "Lead-Free" or "Pb-Free" mean semiconductor products that are compatible with the current RoHS requirements for all 6 substances, including the requirement that lead not exceed 0.1% by weight in homogeneous materials. Where designed to be soldered at high temperatures, TI Pb-Free products are suitable for use in specified lead-free processes.

**Pb-Free (RoHS Exempt):** This component has a RoHS exemption for either 1) lead-based flip-chip solder bumps used between the die and package, or 2) lead-based die adhesive used between the die and leadframe. The component is otherwise considered Pb-Free (RoHS compatible) as defined above.

**Green (RoHS & no Sb/Br):** TI defines "Green" to mean Pb-Free (RoHS compatible), and free of Bromine (Br) and Antimony (Sb) based flame retardants (Br or Sb do not exceed 0.1% by weight in homogeneous material)

(3) MSL, Peak Temp. - The Moisture Sensitivity Level rating according to the JEDEC industry standard classifications, and peak solder temperature.

(4) There may be additional marking, which relates to the logo, the lot trace code information, or the environmental category on the device.

(5) Multiple Device Markings will be inside parentheses. Only one Device Marking contained in parentheses and separated by a "~" will appear on a device. If a line is indented then it is a continuation of the previous line and the two combined represent the entire Device Marking for that device.

(6) Lead/Ball Finish - Orderable Devices may have multiple material finish options. Finish options are separated by a vertical ruled line. Lead/Ball Finish values may wrap to two lines if the finish value exceeds the maximum column width.

**Important Information and Disclaimer:** The information provided on this page represents TI's knowledge and belief as of the date that it is provided. TI bases its knowledge and belief on information provided by third parties, and makes no representation or warranty as to the accuracy of such information. Efforts are underway to better integrate information from third parties. TI has taken and continues to take reasonable steps to provide representative and accurate information but may not have conducted destructive testing or chemical analysis on incoming materials and chemicals. TI and TI suppliers consider certain information to be proprietary, and thus CAS numbers and other limited information may not be available for release.

In no event shall TI's liability arising out of such information exceed the total purchase price of the TI part(s) at issue in this document sold by TI to Customer on an annual basis.



## TAPE AND REEL INFORMATION

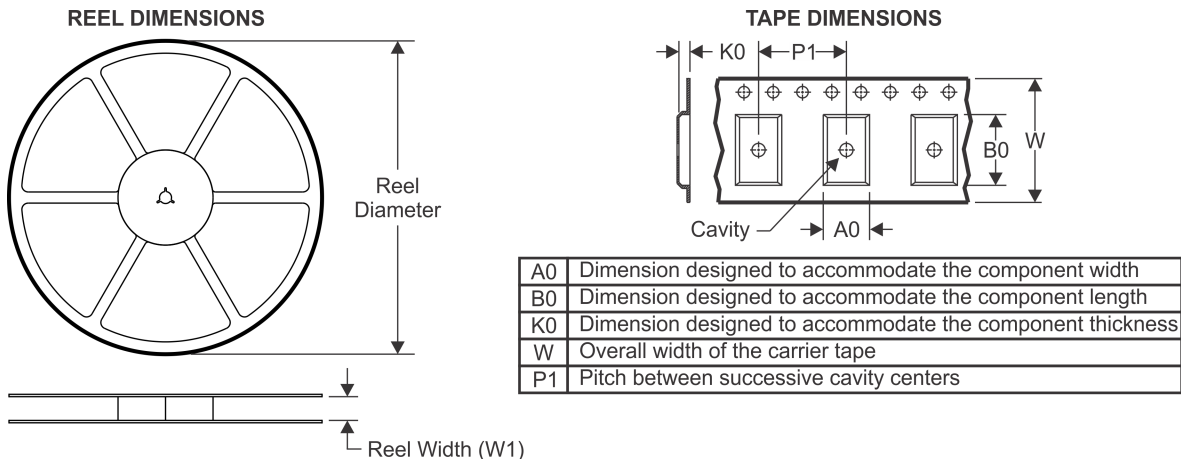

### QUADRANT ASSIGNMENTS FOR PIN 1 ORIENTATION IN TAPE



\*All dimensions are nominal

Device	Package Type	Package Drawing	Pins	SPQ	Reel Diameter (mm)	Reel Width W1 (mm)	A0 (mm)	B0 (mm)	K0 (mm)	P1 (mm)	W (mm)	Pin1 Quadrant
TPD8S009DSMR	SON	DSM	15	3000	180.0	12.4	2.75	6.75	0.95	4.0	12.0	Q1

TAPE AND REEL BOX DIMENSIONS





\*All dimensions are nominal

Device	Package Type	Package Drawing	Pins	SPQ	Length (mm)	Width (mm)	Height (mm)
TPD8S009DSMR	SON	DSM	15	3000	203.0	203.0	35.0

DSM (R-PDSO-N15)

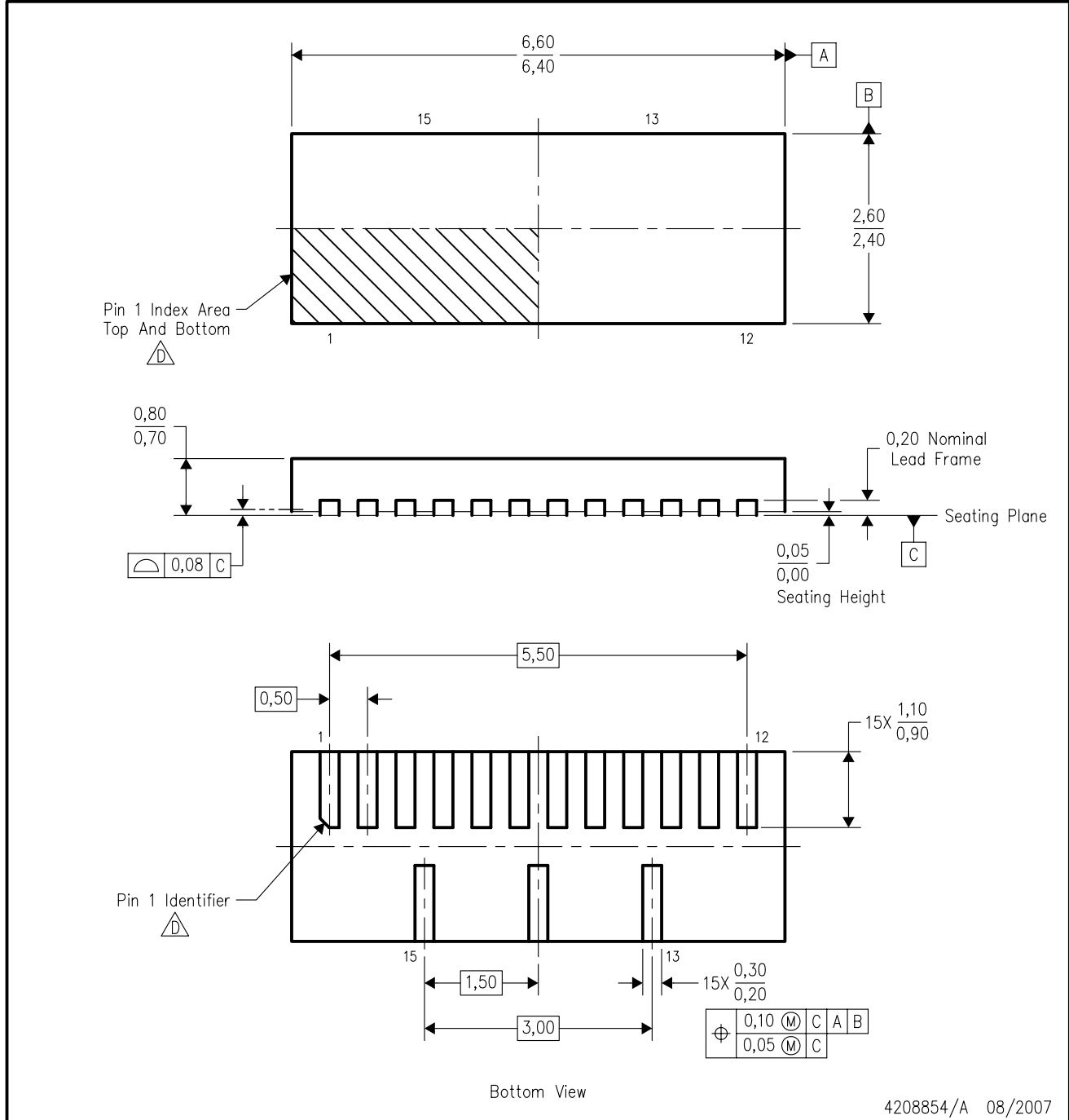
PLASTIC SMALL OUTLINE



- NOTES:
- A. All linear dimensions are in millimeters. Dimensioning and tolerancing per ASME Y14.5M-1994.
  - B. This drawing is subject to change without notice.
  - C. SON (Small Outline No-Lead) package configuration.
  -  Pin 1 identifiers are located on both top and bottom of the package and within the zone indicated. The Pin 1 identifiers are either a molded, marked, or metal feature.

DSM (R-PDSO-N15)

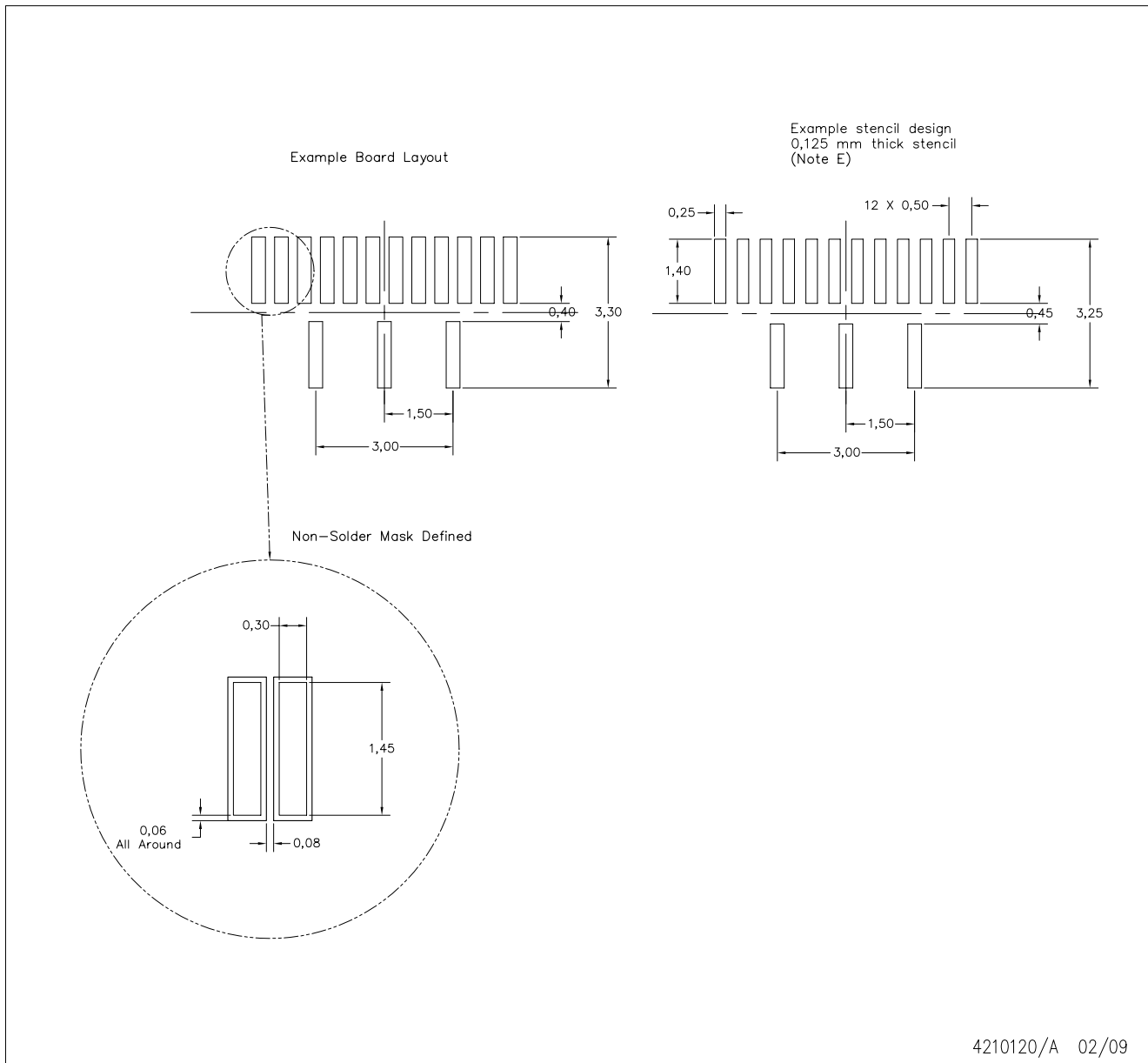

- NOTES:
- All linear dimensions are in millimeters.
  - This drawing is subject to change without notice.
  - Publication IPC-7351 is recommended for alternate designs.
  - Laser cutting apertures with trapezoidal walls and also rounding corners will offer better paste release. Customers should contact their board assembly site for stencil design recommendations. Refer to IPC 7525 for stencil design considerations.
  - Customers should contact their board fabrication site for minimum solder mask web tolerances between signal pads.

DSM (R-PDSO-N15)

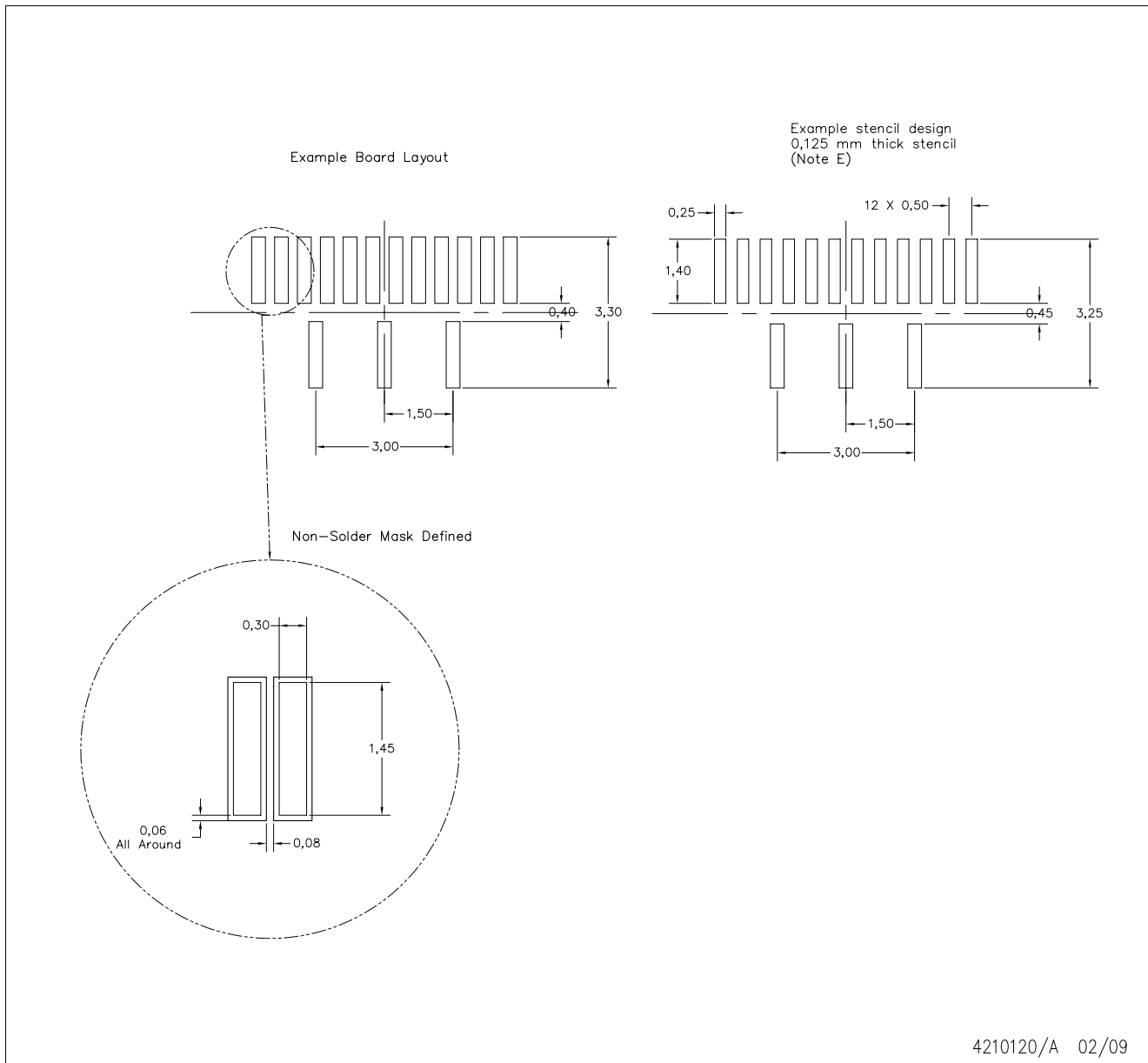

- NOTES:
- All linear dimensions are in millimeters.
  - This drawing is subject to change without notice.
  - Publication IPC-7351 is recommended for alternate designs.
  - Laser cutting apertures with trapezoidal walls and also rounding corners will offer better paste release. Customers should contact their board assembly site for stencil design recommendations. Refer to IPC 7525 for stencil design considerations.
  - Customers should contact their board fabrication site for minimum solder mask web tolerances between signal pads.

## IMPORTANT NOTICE AND DISCLAIMER

TI PROVIDES TECHNICAL AND RELIABILITY DATA (INCLUDING DATASHEETS), DESIGN RESOURCES (INCLUDING REFERENCE DESIGNS), APPLICATION OR OTHER DESIGN ADVICE, WEB TOOLS, SAFETY INFORMATION, AND OTHER RESOURCES "AS IS" AND WITH ALL FAULTS, AND DISCLAIMS ALL WARRANTIES, EXPRESS AND IMPLIED, INCLUDING WITHOUT LIMITATION ANY IMPLIED WARRANTIES OF MERCHANTABILITY, FITNESS FOR A PARTICULAR PURPOSE OR NON-INFRINGEMENT OF THIRD PARTY INTELLECTUAL PROPERTY RIGHTS.

These resources are intended for skilled developers designing with TI products. You are solely responsible for (1) selecting the appropriate TI products for your application, (2) designing, validating and testing your application, and (3) ensuring your application meets applicable standards, and any other safety, security, or other requirements. These resources are subject to change without notice. TI grants you permission to use these resources only for development of an application that uses the TI products described in the resource. Other reproduction and display of these resources is prohibited. No license is granted to any other TI intellectual property right or to any third party intellectual property right. TI disclaims responsibility for, and you will fully indemnify TI and its representatives against, any claims, damages, costs, losses, and liabilities arising out of your use of these resources.

TI's products are provided subject to TI's Terms of Sale ([www.ti.com/legal/termsofsale.html](http://www.ti.com/legal/termsofsale.html)) or other applicable terms available either on [ti.com](http://ti.com) or provided in conjunction with such TI products. TI's provision of these resources does not expand or otherwise alter TI's applicable warranties or warranty disclaimers for TI products.

Mailing Address: Texas Instruments, Post Office Box 655303, Dallas, Texas 75265  
Copyright © 2019, Texas Instruments Incorporated

## Looking for pricing, stock, or lifecycle information?

Click below to explore more details on WIN SOURCE:

 [View TPD8S009DSMR](#) on WIN SOURCE

 [Texas Instruments](#) Information

## Optimize Your Supply Chain with WIN SOURCE Solutions

-  Global Sourcing Solution
-  Obsolete Management
-  Cost Control Management
-  Shortage Management
-  Alternative Solution
-  Excess Inventory Management