



THE DATASHEET OF TPS3818G25DRVR



Low Quiescent Current, Accurate Programmable-Delay Supervisory Circuit

FEATURES

- Power-On Reset Generator with Adjustable Delay Time: 1.25ms to 10s
- Very Low Quiescent Current: 2.4 μ A typ
- High Threshold Accuracy: 0.5% typ
- Fixed Threshold Voltages for Standard Voltage Rails from 0.9V to 5V and Adjustable Voltage Down to 0.4V Are Available
- Manual Reset ($\overline{\text{MR}}$) Input
- Open-Drain $\overline{\text{RESET}}$ Output
- Temperature Range: -40°C to $+125^{\circ}\text{C}$
- Small SOT23 and 2mm x 2mm QFN Packages

APPLICATIONS

- DSP or Microcontroller Applications
- Notebook/Desktop Computers
- PDAs/Hand-Held Products
- Portable/Battery-Powered Products
- FPGA/ASIC Applications

DESCRIPTION

The TPS3818xxx family of microprocessor supervisory circuits monitor system voltages from 0.4V to 5.0V, asserting an open-drain $\overline{\text{RESET}}$ signal when the SENSE voltage drops below a preset threshold or when the manual reset ($\overline{\text{MR}}$) pin drops to a logic low. The $\overline{\text{RESET}}$ output remains low for the user-adjustable delay time after the SENSE voltage and manual reset ($\overline{\text{MR}}$) return above the respective thresholds.

The TPS3818 uses a precision reference to achieve 0.5% threshold accuracy for $V_{\text{IT}} \leq 3.3\text{V}$. The reset delay time can be set to 20ms by disconnecting the C_{T} pin, 300ms by connecting the C_{T} pin to V_{DD} using a resistor, or can be user-adjusted between 1.25ms and 10s by connecting the C_{T} pin to an external capacitor. When used with an external capacitor, the TPS3818xxx gives a more accurate delay time than the similar TPS3808xxx device. The TPS3818 has a very low typical quiescent current of 2.4 μ A so it is well-suited to battery-powered applications. It is available in either a small SOT23 and an ultra-small 2mm x 2mm QFN PowerPAD™ package, and is fully specified over a temperature range of -40°C to $+125^{\circ}\text{C}$ (T_{J}).

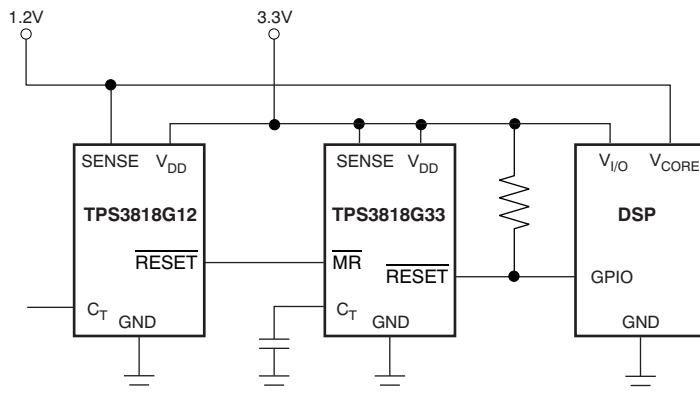

Typical Application Circuit

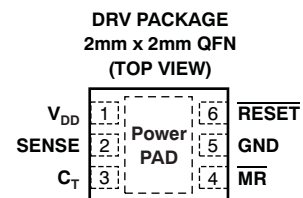
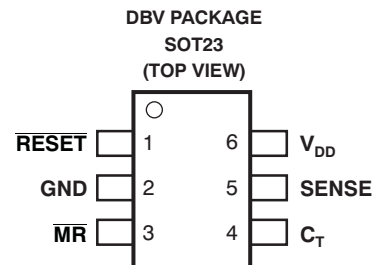

Please be aware that an important notice concerning availability, standard warranty, and use in critical applications of Texas Instruments semiconductor products and disclaimers thereto appears at the end of this data sheet.

PowerPAD is a trademark of Texas Instruments.
All other trademarks are the property of their respective owners.



This integrated circuit can be damaged by ESD. Texas Instruments recommends that all integrated circuits be handled with appropriate precautions. Failure to observe proper handling and installation procedures can cause damage.

ESD damage can range from subtle performance degradation to complete device failure. Precision integrated circuits may be more susceptible to damage because very small parametric changes could cause the device not to meet its published specifications.

ORDERING INFORMATION⁽¹⁾

PRODUCT	NOMINAL SUPPLY VOLTAGE ⁽²⁾	THRESHOLD VOLTAGE (V_{IT})
TPS3818G01	Adjustable	0.405V
TPS3818G09	0.9V	0.84V
TPS3818G12	1.2V	1.12V
TPS3818G125	1.25V	1.16V
TPS3818G15	1.5V	1.40V
TPS3818G18	1.8V	1.67V
TPS3818G25	2.5V	2.33V
TPS3818G30	3.0V	2.79V
TPS3818G33	3.3V	3.07V
TPS3818G50	5.0V	4.65V

- (1) For the most current package and ordering information see the Package Option Addendum at the end of this document, or see the TI web site at www.ti.com.
- (2) Custom threshold voltages from 0.82V to 3.3V, 4.4V to 5.0V are available through the use of factory EEPROM programming. Minimum order quantities apply. Contact factory for details and availability.

ABSOLUTE MAXIMUM RATINGS⁽¹⁾

Over operating junction temperature range, unless otherwise noted.

	TPS3818	UNIT
Input voltage range, V_{DD}	-0.3 to 7.0	V
C_T voltage range, V_{CT}	-0.3 to $V_{DD} + 0.3$	V
Other voltage ranges: V_{RESET} , V_{MR} , V_{SENSE}	-0.3 to 7	V
\overline{RESET} pin current	5	mA
Operating junction temperature range, T_J ⁽²⁾	-40 to +150	°C
Storage temperature range, T_{STG}	-65 to +150	°C
ESD rating, HBM	2	kV
ESD rating, CDM	500	V

- (1) Stresses beyond those listed under *absolute maximum ratings* may cause permanent damage to the device. These are stress ratings only, and functional operation of the device at these or any other conditions beyond those indicated under the [Electrical Characteristics](#) is not implied. Exposure to absolute maximum rated conditions for extended periods may affect device reliability.
- (2) As a result of the low dissipated power in this device, it is assumed that $T_J = T_A$.

ELECTRICAL CHARACTERISTICS

1.7V ≤ V_{DD} ≤ 6.5V, R_{LRESET} = 100kΩ, C_{LRESET} = 50pF, over operating temperature range (T_J = –40°C to +125°C), unless otherwise noted. Typical values are at T_J = +25°C.

PARAMETER		TEST CONDITIONS	MIN	TYP	MAX	UNIT		
V _{DD}	Input supply range	–40°C < T _J < +125°C	1.7		6.5	V		
		0°C < T _J < +85°C	1.65		6.5			
I _{DD}	Supply current (current into V _{DD} pin)	V _{DD} = 3.3V, $\overline{\text{RESET}}$ not asserted $\overline{\text{MR}}$, $\overline{\text{RESET}}$, C _T open		2.4	5.0	μA		
		V _{DD} = 6.5V, $\overline{\text{RESET}}$ not asserted $\overline{\text{MR}}$, $\overline{\text{RESET}}$, C _T open		2.7	6.0	μA		
V _{OL}	Low-level output voltage	1.3V ≤ V _{DD} < 1.8V, I _{OL} = 0.4mA			0.3	V		
		1.8V ≤ V _{DD} ≤ 6.5V, I _{OL} = 1.0mA			0.4	V		
	Power-up reset voltage ⁽¹⁾	V _{OL} (max) = 0.2V, I _{RESET} = 15μA			0.8	V		
V _{IT}	Negative-going input threshold accuracy	TPS3818G01		–2.0	±1.0	±2.0	%	
		V _{IT} ≤ 3.3V		–1.5	±0.5	±1.5		
		3.3V < V _{IT} ≤ 5.0V		–2.0	±1.0	±2.0		
		V _{IT} ≤ 3.3V	–40°C < T _J < +85°C	–1.25	±0.5	±1.25		
		3.3V < V _{IT} ≤ 5.0V	–40°C < T _J < +85°C	–1.5	±0.5	±1.5		
V _{HYS}	Hysteresis on V _{IT} pin	TPS3818G01			1.5	3.0	%V _{IT}	
		Fixed versions	–40°C < T _J < +85°C			1.0		2.0
						1.0		2.5
R _{MR}	$\overline{\text{MR}}$ Internal pull-up resistance		70	90		kΩ		
I _{SENSE}	Input current at SENSE pin	TPS3818G01	V _{SENSE} = V _{IT}	–25		25	nA	
		Fixed versions	V _{SENSE} = 6.5V		1.7		μA	
I _{OH}	$\overline{\text{RESET}}$ leakage current	V _{RESET} = 6.5V, $\overline{\text{RESET}}$ not asserted			300	nA		
C _{IN}	Input capacitance, any pin	C _T pin	V _{IN} = 0V to V _{DD}		5	pF		
		Other pins	V _{IN} = 0V to 6.5V		5			
V _{IL}	$\overline{\text{MR}}$ logic low input		0		0.3 V _{DD}	V		
V _{IH}	$\overline{\text{MR}}$ logic high input		0.7 V _{DD}		V _{DD}	V		
t _w	Input pulse width to $\overline{\text{RESET}}$	SENSE	V _{IH} = 1.05V _{IT} , V _{IL} = 0.95V _{IT}		20	μs		
		$\overline{\text{MR}}$	V _{IH} = 0.7V _{DD} , V _{IL} = 0.3V _{DD}		0.001			
t _d	$\overline{\text{RESET}}$ delay time ⁽²⁾	C _T = Open	See Timing Diagram	12	20	28	ms	
		C _T = V _{DD}		180	300	420	ms	
V _{CT}	CT pin ($\overline{\text{RESET}}$ delay time) comparator threshold ⁽³⁾		1.211	1.23	1.249	V		
I _{CT}	CT pin ($\overline{\text{RESET}}$ delay time) charging current ⁽³⁾	R _{CT} = 2MΩ (resistor between C _T and GND)	190	220	250	nA		
t _{pHL}	Propagation delay	$\overline{\text{MR}}$ to $\overline{\text{RESET}}$	V _{IH} = 0.7V _{DD} , V _{IL} = 0.3V _{DD}		150		ns	
	High to low level $\overline{\text{RESET}}$ delay	SENSE to $\overline{\text{RESET}}$	V _{IH} = 1.05V _{IT} , V _{IL} = 0.95V _{IT}		20		μs	
θ _{JA}	Thermal resistance, junction-to-ambient			290		°C/W		

(1) The lowest supply voltage (V_{DD}) at which $\overline{\text{RESET}}$ becomes active. T_{rise(VDD)} ≥ 15μs/V.

(2) The delay time accuracy without external capacitor is the same as that of the TPS3808xxx. This specification is included here for TPS3808xxx device comparison.

(3) The combined $\overline{\text{RESET}}$ delay time accuracy from V_{CT} and I_{CT} is ±15%.

FUNCTIONAL BLOCK DIAGRAMS

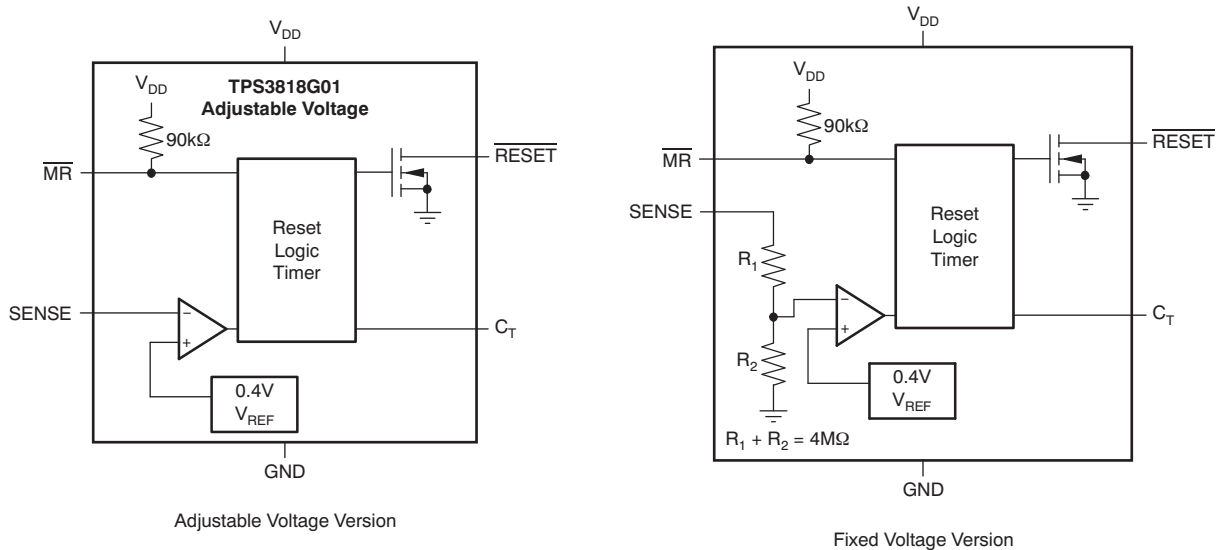

Figure 1. Adjustable and Fixed Voltage Versions

PIN ASSIGNMENTS

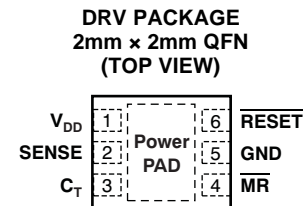
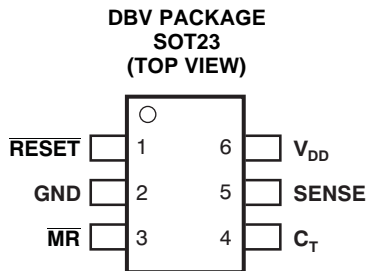

Table 1. TERMINAL FUNCTIONS

TERMINAL		DESCRIPTION
NAME	SOT23 (DBV) PIN NO.	
$\overline{\text{RESET}}$	1	$\overline{\text{RESET}}$ is an open-drain output that is driven to a low impedance state when $\overline{\text{RESET}}$ is asserted (either the SENSE input is lower than the threshold voltage (V_{IT}) or the $\overline{\text{MR}}$ pin is set to a logic low). $\overline{\text{RESET}}$ remains low (asserted) for the reset period after both SENSE is above V_{IT} and $\overline{\text{MR}}$ is set to a logic high. A pull-up resistor from 10k Ω to 1M Ω should be used on this pin, and allows the reset pin to attain voltages higher than V_{DD} .
GND	2	Ground
$\overline{\text{MR}}$	3	Driving the manual reset pin ($\overline{\text{MR}}$) low asserts $\overline{\text{RESET}}$. $\overline{\text{MR}}$ is internally tied to V_{DD} by a 90k Ω pull-up resistor.
C_T	4	Reset period programming pin. Connecting this pin to V_{DD} through a 40k Ω to 200k Ω resistor or leaving it open results in fixed delay times (see Electrical Characteristics). Connecting this pin to a ground referenced capacitor $\geq 100\text{pF}$ gives a user-programmable delay time. See the Selecting the Reset Delay Time section for more information.
SENSE	5	This pin is connected to the voltage to be monitored. If the voltage at this terminal drops below the threshold voltage V_{IT} , then $\overline{\text{RESET}}$ is asserted.
V_{DD}	6	Supply voltage. It is good analog design practice to place a 0.1 μF ceramic capacitor close to this pin.
PowerPAD		PowerPAD. Connect to ground plane to enhance thermal performance of package.

TIMING DIAGRAM

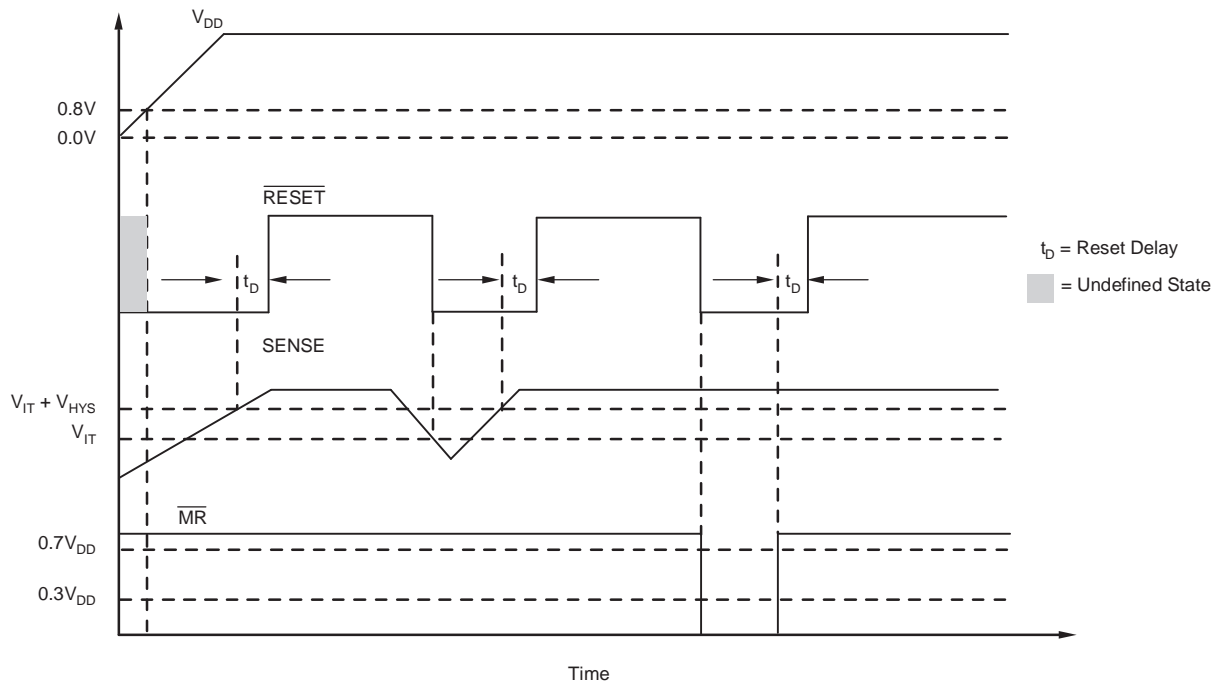

Figure 2. TPS3818 Timing Diagram Showing \overline{MR} and SENSE Reset Timing

TRUTH TABLE

\overline{MR}	SENSE > V_{IT}	\overline{RESET}
L	0	L
L	1	L
H	0	L
H	1	H

TYPICAL CHARACTERISTICS

At $T_J = +25^\circ\text{C}$, $V_{DD} = 3.3\text{V}$, $R_{L\text{RESET}} = 100\text{k}\Omega$, and $C_{L\text{RESET}} = 50\text{pF}$, unless otherwise noted.

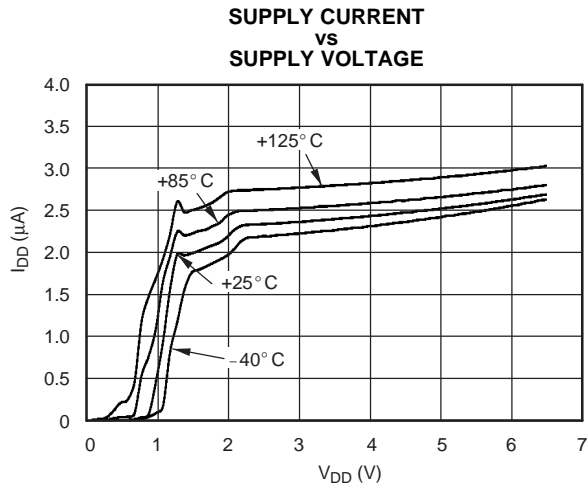

Figure 3.

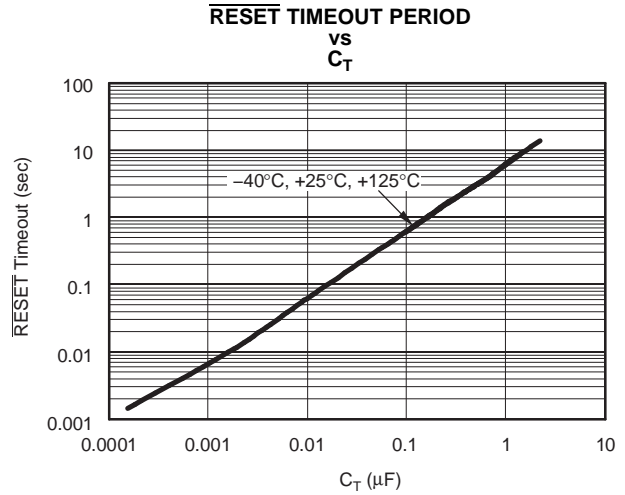

Figure 4.

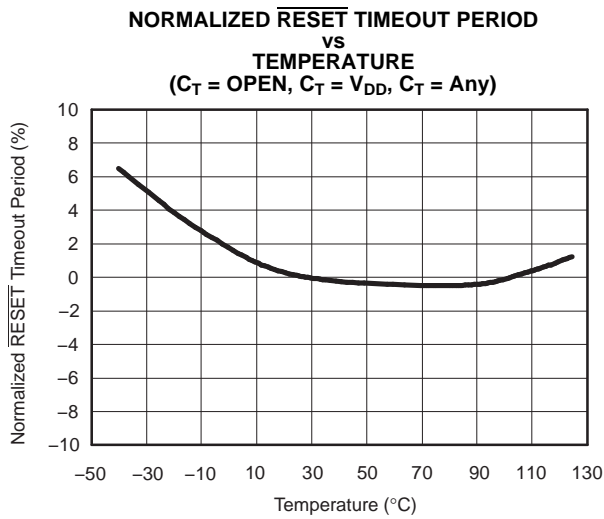

Figure 5.

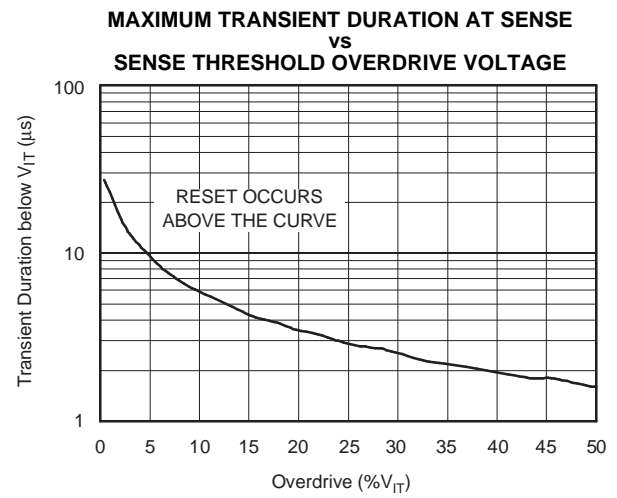

Figure 6.

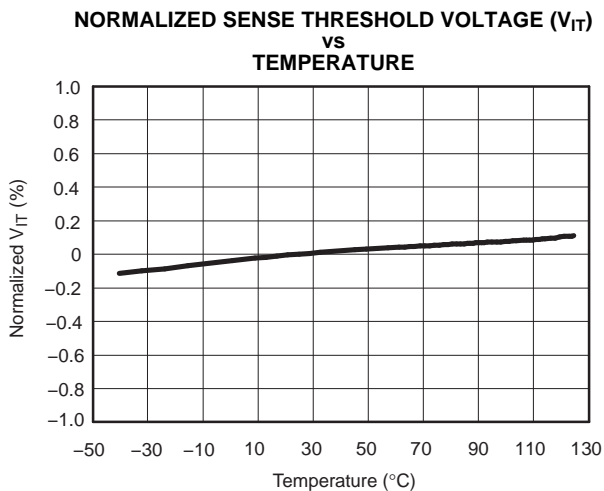

Figure 7.

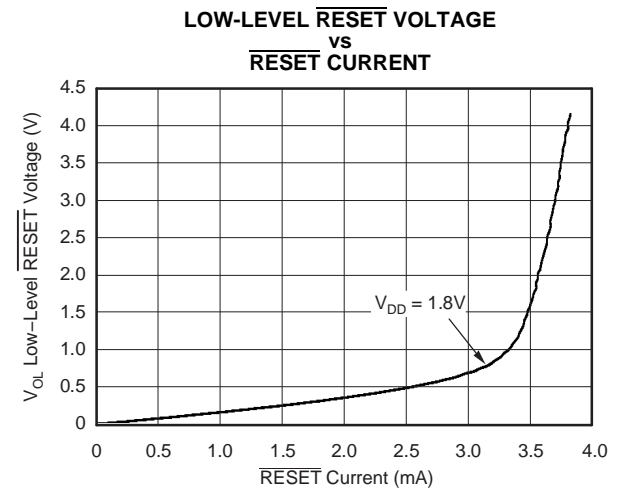

Figure 8.

TYPICAL CHARACTERISTICS (continued)

At $T_J = +25^\circ\text{C}$, $V_{DD} = 3.3\text{V}$, $R_{LRESET} = 100\text{k}\Omega$, and $C_{LRESET} = 50\text{pF}$, unless otherwise noted.

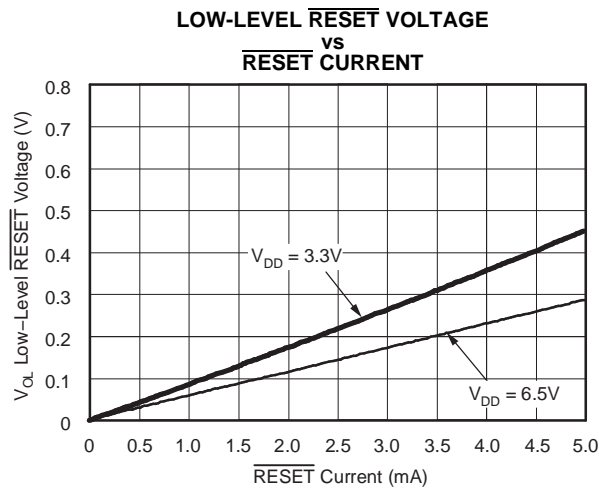

Figure 9.

DEVICE OPERATION

The TPS3818 microprocessor supervisory product family is designed to assert a $\overline{\text{RESET}}$ signal when either the SENSE pin voltage drops below V_{IT} or the manual reset (MR) is driven low. The RESET output remains asserted for a user-adjustable time after both the manual reset ($\overline{\text{MR}}$) and SENSE voltages return above the respective thresholds. A broad range of voltage threshold and reset delay time adjustments are available, allowing these devices to be used in a wide array of applications. Reset threshold voltages can be factory-set from 0.82V to 3.3V or from 4.4V to 5.0V, while the TPS3818G01 can be set to any voltage above 0.405V using an external resistor divider. Two preset delay times are also user-selectable: connecting the C_T pin to V_{DD} results in a 300ms reset delay, while leaving the C_T pin open yields a 20ms reset delay. In addition, connecting a capacitor between C_T and GND allows the designer to select any reset delay period from 1.25ms to 10s.

RESET OUTPUT

A typical application of the TPS3818G25 used with the OMAP1510 processor is shown in Figure 10. The open-drain RESET output is typically connected to the $\overline{\text{RESET}}$ input of a microprocessor. A pull-up resistor must be used to hold this line high when $\overline{\text{RESET}}$ is not asserted. The RESET output is undefined for voltage below 0.8V, but this is normally not a problem because most microprocessors do not function below this voltage. RESET remains high (unasserted) as long as SENSE is above its threshold (V_{IT}) and the manual reset ($\overline{\text{MR}}$) is logic high. If either SENSE falls below V_{IT} or $\overline{\text{MR}}$ is driven low, $\overline{\text{RESET}}$ is asserted, driving the $\overline{\text{RESET}}$ pin to a low impedance.

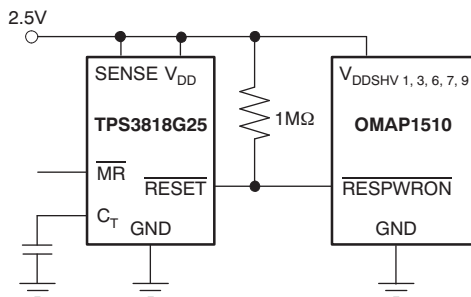

Figure 10. Typical Application of the TPS3818 with an OMAP Processor

Once $\overline{\text{MR}}$ is again logic high and SENSE is above $V_{IT} + V_{HYS}$ (the threshold hysteresis), a delay circuit is enabled that holds $\overline{\text{RESET}}$ low for a specified reset delay period. Once the reset delay has expired, the $\overline{\text{RESET}}$ pin goes to a high impedance state. The pull-up resistor from the open-drain $\overline{\text{RESET}}$ to the

supply line can be used to allow the reset signal for the microprocessor to have a voltage higher than V_{DD} (up to 6.5V). The pull-up resistor should be no smaller than 10kΩ as a result of the finite impedance of the $\overline{\text{RESET}}$ line.

SENSE INPUT

The SENSE input provides a terminal at which any system voltage can be monitored. If the voltage on this pin drops below V_{IT} , then $\overline{\text{RESET}}$ is asserted. The comparator has a built-in hysteresis to ensure smooth $\overline{\text{RESET}}$ assertions and de-assertions. It is good analog design practice to put a 1nF to 10nF bypass capacitor on the SENSE input to reduce sensitivity to transients and layout parasitics.

The TPS3818G01 can be used to monitor any voltage rail down to 0.405V using the circuit shown in Figure 11.

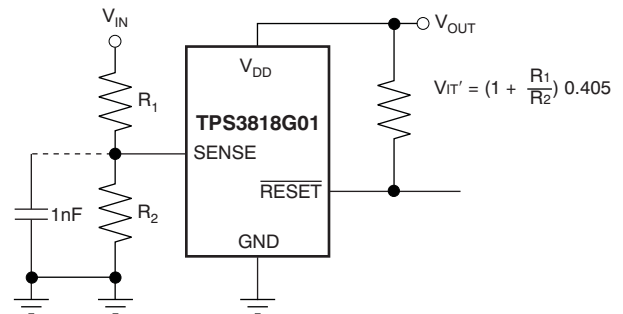

Figure 11. Using the TPS3818G01 to Monitor a User-Defined Threshold Voltage

MANUAL RESET ($\overline{\text{MR}}$) INPUT

The manual reset ($\overline{\text{MR}}$) input allows a processor or other logic circuit to initiate a reset. A logic low ($0.3V_{DD}$) on MR causes $\overline{\text{RESET}}$ to assert. After MR returns to a logic high and SENSE is above its reset threshold, $\overline{\text{RESET}}$ is de-asserted after the user-defined reset delay expires. Note that $\overline{\text{MR}}$ is internally tied to V_{DD} using a 90kΩ resistor so this pin can be left unconnected if MR is not used.

See Figure 12 for how $\overline{\text{MR}}$ can be used to monitor multiple system voltages. Note that if the logic signal driving $\overline{\text{MR}}$ does not go fully to V_{DD} , there will be some additional current draw into V_{DD} as a result of the internal pull-up resistor on MR. To minimize current draw, a logic-level FET can be used as illustrated in Figure 13.

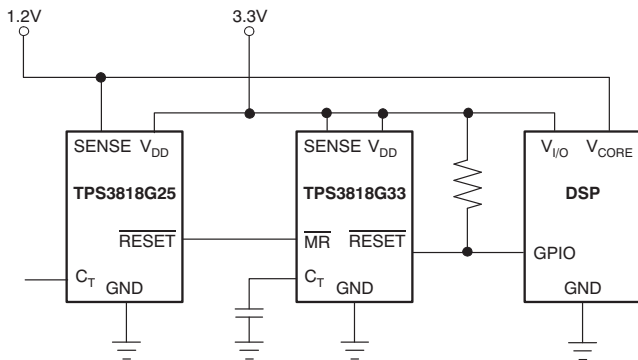

Figure 12. Using $\overline{\text{MR}}$ to Monitor Multiple System Voltages

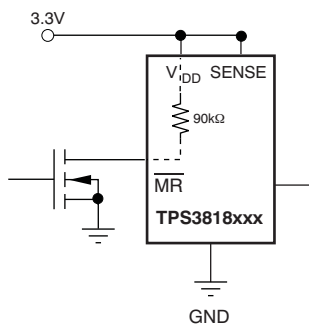

Figure 13. Using an External MOSFET to Minimize I_{DD} When MR Signal Does Not Go to V_{DD}

SELECTING THE RESET DELAY TIME

The TPS3818 has three options for setting the $\overline{\text{RESET}}$ delay time as shown in Figure 14. Figure 14a shows the configuration for a fixed 300ms typical delay time by tying C_{T} to V_{DD} ; a resistor from 40kΩ to 200kΩ must be used. Supply current is not affected

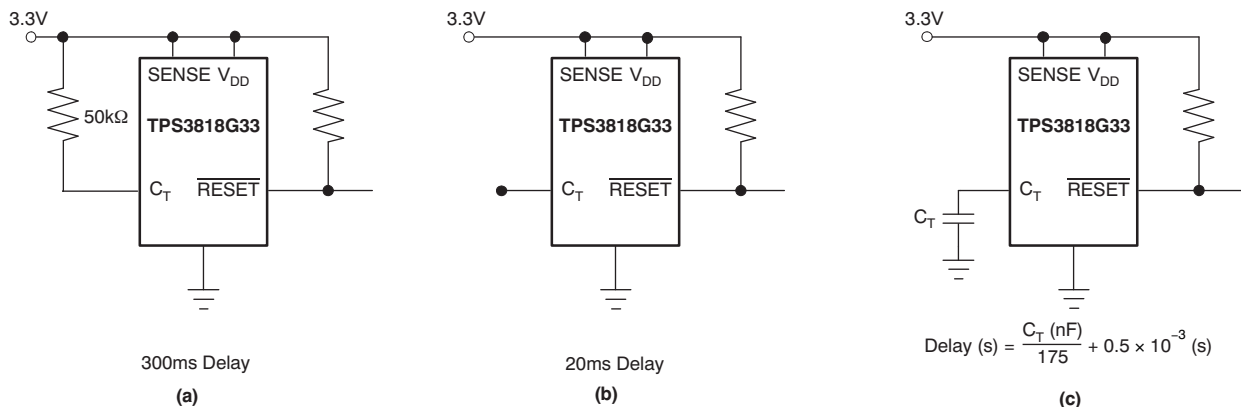

Figure 14. Configuration Used to Set the $\overline{\text{RESET}}$ Delay Time

by the choice of resistor. Figure 14b shows a fixed 20ms delay time by leaving the C_{T} pin open. Figure 14c shows a ground referenced capacitor connected to C_{T} for a user-defined program time between 1.25ms and 10s.

The capacitor C_{T} should be $\geq 100\text{pF}$ nominal value in order for the TPS3818xxx to recognize that the capacitor is present. The capacitor value for a given delay time can be calculated using the following equation:

$$C_{\text{T}} (\text{nF}) = [t_{\text{D}} (\text{s}) - 0.5 \times 10^{-3} (\text{s})] \times 175 \quad (1)$$

The reset delay time is determined by the time it takes an on-chip precision 220nA current source to charge the external capacitor to 1.23V. When a $\overline{\text{RESET}}$ is asserted the capacitor is discharged. When the $\overline{\text{RESET}}$ conditions are cleared, the internal current source is enabled and begins to charge the external capacitor. When the voltage on this capacitor reaches 1.23V, $\overline{\text{RESET}}$ is de-asserted. Note that a low leakage type capacitor such as a ceramic should be used, and that stray capacitance around this pin may cause errors in the reset delay time.

IMMUNITY TO SENSE PIN VOLTAGE TRANSIENTS

The TPS3818 is relatively immune to short negative transients on the SENSE pin. Sensitivity to transients depends on threshold overdrive, as shown in the Maximum Transient Duration at Sense vs Sense Threshold Overdrive Voltage graph (Figure 6) in the Typical Characteristics section.

PACKAGING INFORMATION

Orderable Device	Status (1)	Package Type	Package Drawing	Pins	Package Qty	Eco Plan (2)	Lead/Ball Finish (6)	MSL Peak Temp (3)	Op Temp (°C)	Device Marking (4/5)	Samples
TPS3818G25DRVVT	ACTIVE	WSON	DRV	6	250	Green (RoHS & no Sb/Br)	CU NIPDAU	Level-1-260C-UNLIM	-40 to 125	CHJ	Samples

(1) The marketing status values are defined as follows:

ACTIVE: Product device recommended for new designs.

LIFEBUY: TI has announced that the device will be discontinued, and a lifetime-buy period is in effect.

NRND: Not recommended for new designs. Device is in production to support existing customers, but TI does not recommend using this part in a new design.

PREVIEW: Device has been announced but is not in production. Samples may or may not be available.

OBSELETE: TI has discontinued the production of the device.

(2) Eco Plan - The planned eco-friendly classification: Pb-Free (RoHS), Pb-Free (RoHS Exempt), or Green (RoHS & no Sb/Br) - please check <http://www.ti.com/productcontent> for the latest availability information and additional product content details.

TBD: The Pb-Free/Green conversion plan has not been defined.

Pb-Free (RoHS): TI's terms "Lead-Free" or "Pb-Free" mean semiconductor products that are compatible with the current RoHS requirements for all 6 substances, including the requirement that lead not exceed 0.1% by weight in homogeneous materials. Where designed to be soldered at high temperatures, TI Pb-Free products are suitable for use in specified lead-free processes.

Pb-Free (RoHS Exempt): This component has a RoHS exemption for either 1) lead-based flip-chip solder bumps used between the die and package, or 2) lead-based die adhesive used between the die and leadframe. The component is otherwise considered Pb-Free (RoHS compatible) as defined above.

Green (RoHS & no Sb/Br): TI defines "Green" to mean Pb-Free (RoHS compatible), and free of Bromine (Br) and Antimony (Sb) based flame retardants (Br or Sb do not exceed 0.1% by weight in homogeneous material)

(3) MSL, Peak Temp. - The Moisture Sensitivity Level rating according to the JEDEC industry standard classifications, and peak solder temperature.

(4) There may be additional marking, which relates to the logo, the lot trace code information, or the environmental category on the device.

(5) Multiple Device Markings will be inside parentheses. Only one Device Marking contained in parentheses and separated by a "~" will appear on a device. If a line is indented then it is a continuation of the previous line and the two combined represent the entire Device Marking for that device.

(6) Lead/Ball Finish - Orderable Devices may have multiple material finish options. Finish options are separated by a vertical ruled line. Lead/Ball Finish values may wrap to two lines if the finish value exceeds the maximum column width.

Important Information and Disclaimer:The information provided on this page represents TI's knowledge and belief as of the date that it is provided. TI bases its knowledge and belief on information provided by third parties, and makes no representation or warranty as to the accuracy of such information. Efforts are underway to better integrate information from third parties. TI has taken and continues to take reasonable steps to provide representative and accurate information but may not have conducted destructive testing or chemical analysis on incoming materials and chemicals. TI and TI suppliers consider certain information to be proprietary, and thus CAS numbers and other limited information may not be available for release.

In no event shall TI's liability arising out of such information exceed the total purchase price of the TI part(s) at issue in this document sold by TI to Customer on an annual basis.

TAPE AND REEL INFORMATION



QUADRANT ASSIGNMENTS FOR PIN 1 ORIENTATION IN TAPE



*All dimensions are nominal

Device	Package Type	Package Drawing	Pins	SPQ	Reel Diameter (mm)	Reel Width W1 (mm)	A0 (mm)	B0 (mm)	K0 (mm)	P1 (mm)	W (mm)	Pin1 Quadrant
TPS3818G25DRV	WSON	DRV	6	250	179.0	8.4	2.2	2.2	1.2	4.0	8.0	Q2

TAPE AND REEL BOX DIMENSIONS



*All dimensions are nominal

Device	Package Type	Package Drawing	Pins	SPQ	Length (mm)	Width (mm)	Height (mm)
TPS3818G25DRV	WSON	DRV	6	250	203.0	203.0	35.0

GENERIC PACKAGE VIEW

DRV 6

WSON - 0.8 mm max height

PLASTIC SMALL OUTLINE - NO LEAD

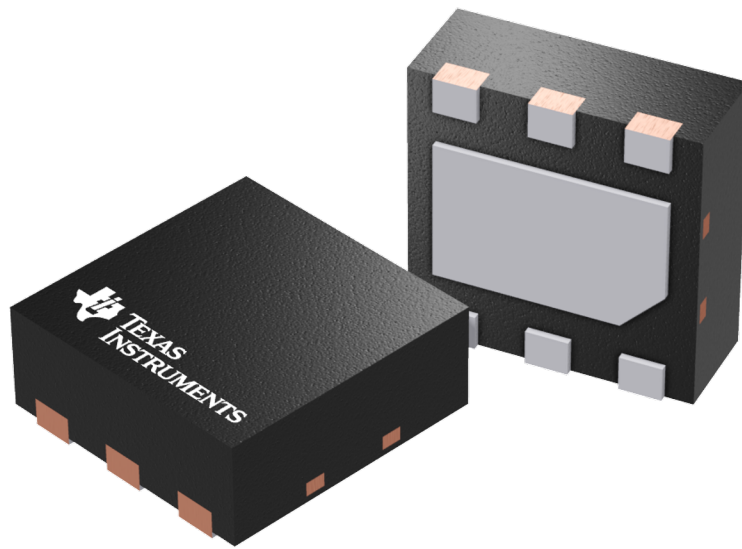

Images above are just a representation of the package family, actual package may vary.
Refer to the product data sheet for package details.

4206925/F

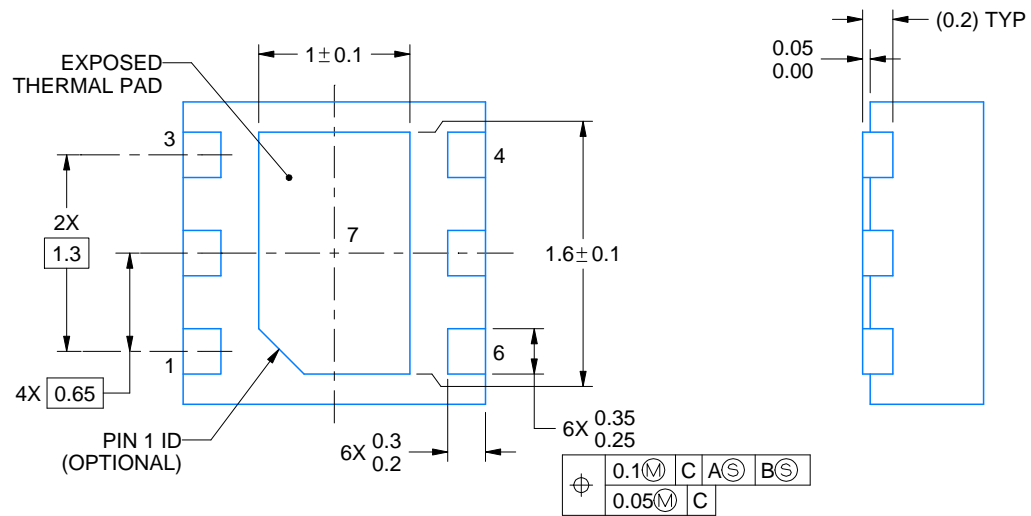
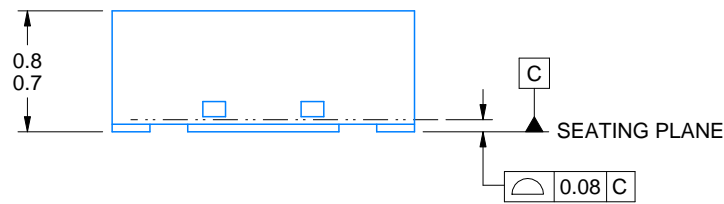
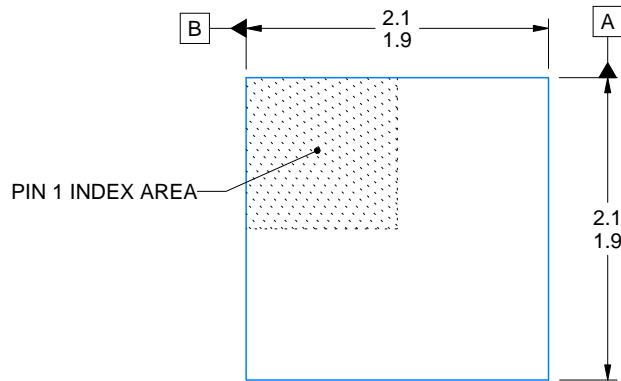
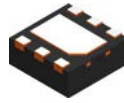

4222173/B 04/2018

NOTES:

1. All linear dimensions are in millimeters. Any dimensions in parenthesis are for reference only. Dimensioning and tolerancing per ASME Y14.5M.
2. This drawing is subject to change without notice.
3. The package thermal pad must be soldered to the printed circuit board for thermal and mechanical performance.

EXAMPLE BOARD LAYOUT

DRV0006A

WSON - 0.8 mm max height

PLASTIC SMALL OUTLINE - NO LEAD

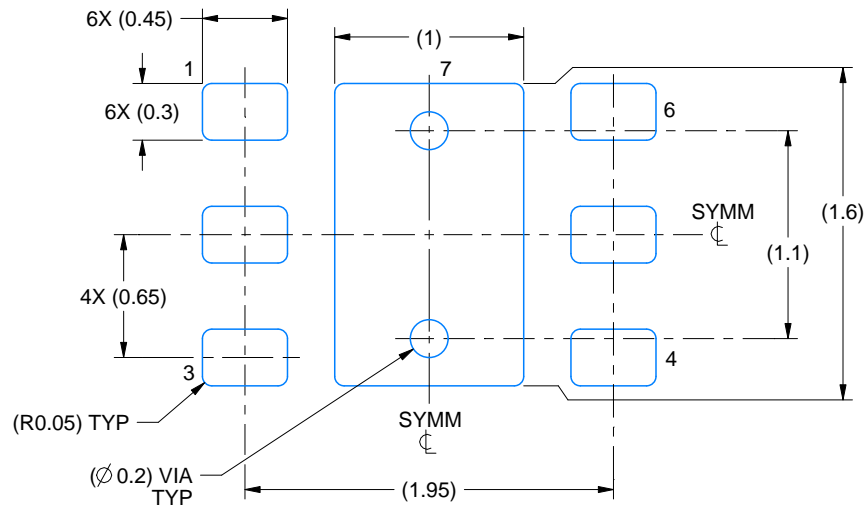

LAND PATTERN EXAMPLE
SCALE:25X

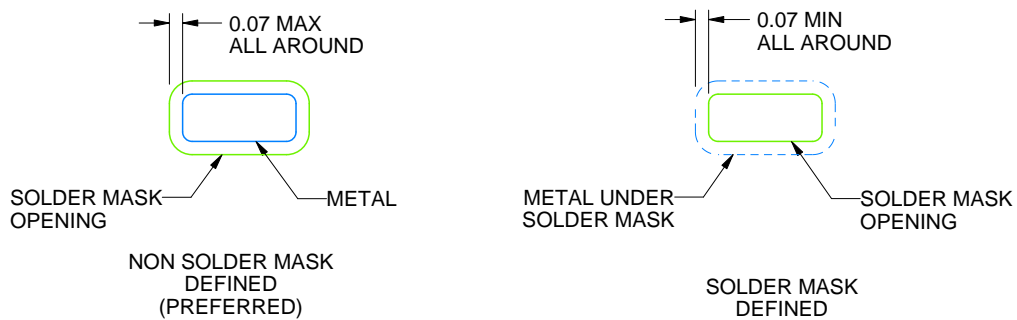

SOLDER MASK DETAILS

4222173/B 04/2018

NOTES: (continued)

4. This package is designed to be soldered to a thermal pad on the board. For more information, see Texas Instruments literature number SLUA271 (www.ti.com/lit/sluea271).
5. Vias are optional depending on application, refer to device data sheet. If some or all are implemented, recommended via locations are shown.

EXAMPLE STENCIL DESIGN

DRV0006A

WSON - 0.8 mm max height

PLASTIC SMALL OUTLINE - NO LEAD

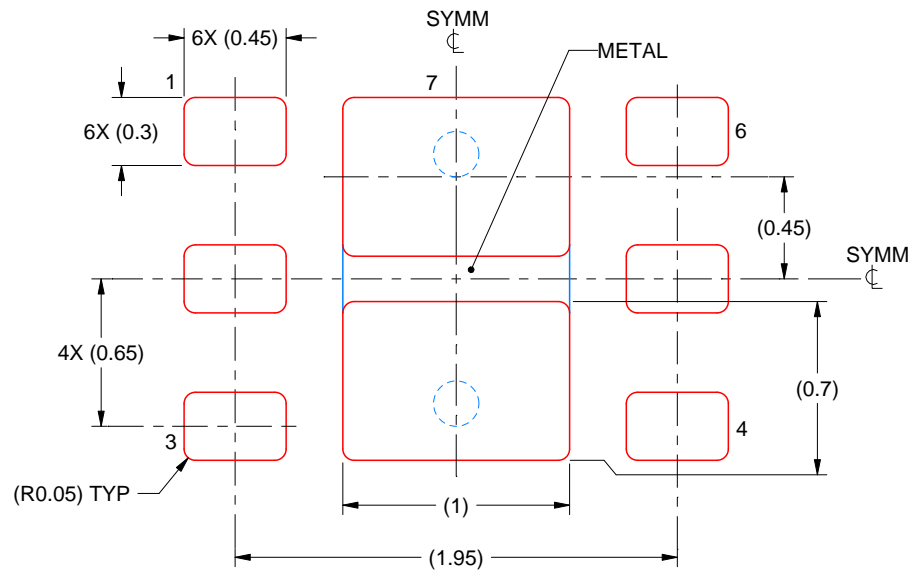

SOLDER PASTE EXAMPLE
BASED ON 0.125 mm THICK STENCIL

EXPOSED PAD #7
88% PRINTED SOLDER COVERAGE BY AREA UNDER PACKAGE
SCALE:30X

4222173/B 04/2018

NOTES: (continued)

6. Laser cutting apertures with trapezoidal walls and rounded corners may offer better paste release. IPC-7525 may have alternate design recommendations.

IMPORTANT NOTICE

Texas Instruments Incorporated (TI) reserves the right to make corrections, enhancements, improvements and other changes to its semiconductor products and services per JESD46, latest issue, and to discontinue any product or service per JESD48, latest issue. Buyers should obtain the latest relevant information before placing orders and should verify that such information is current and complete.

TI's published terms of sale for semiconductor products (<http://www.ti.com/sc/docs/stdterms.htm>) apply to the sale of packaged integrated circuit products that TI has qualified and released to market. Additional terms may apply to the use or sale of other types of TI products and services.

Reproduction of significant portions of TI information in TI data sheets is permissible only if reproduction is without alteration and is accompanied by all associated warranties, conditions, limitations, and notices. TI is not responsible or liable for such reproduced documentation. Information of third parties may be subject to additional restrictions. Resale of TI products or services with statements different from or beyond the parameters stated by TI for that product or service voids all express and any implied warranties for the associated TI product or service and is an unfair and deceptive business practice. TI is not responsible or liable for any such statements.

Buyers and others who are developing systems that incorporate TI products (collectively, "Designers") understand and agree that Designers remain responsible for using their independent analysis, evaluation and judgment in designing their applications and that Designers have full and exclusive responsibility to assure the safety of Designers' applications and compliance of their applications (and of all TI products used in or for Designers' applications) with all applicable regulations, laws and other applicable requirements. Designer represents that, with respect to their applications, Designer has all the necessary expertise to create and implement safeguards that (1) anticipate dangerous consequences of failures, (2) monitor failures and their consequences, and (3) lessen the likelihood of failures that might cause harm and take appropriate actions. Designer agrees that prior to using or distributing any applications that include TI products, Designer will thoroughly test such applications and the functionality of such TI products as used in such applications.

TI's provision of technical, application or other design advice, quality characterization, reliability data or other services or information, including, but not limited to, reference designs and materials relating to evaluation modules, (collectively, "TI Resources") are intended to assist designers who are developing applications that incorporate TI products; by downloading, accessing or using TI Resources in any way, Designer (individually or, if Designer is acting on behalf of a company, Designer's company) agrees to use any particular TI Resource solely for this purpose and subject to the terms of this Notice.

TI's provision of TI Resources does not expand or otherwise alter TI's applicable published warranties or warranty disclaimers for TI products, and no additional obligations or liabilities arise from TI providing such TI Resources. TI reserves the right to make corrections, enhancements, improvements and other changes to its TI Resources. TI has not conducted any testing other than that specifically described in the published documentation for a particular TI Resource.

Designer is authorized to use, copy and modify any individual TI Resource only in connection with the development of applications that include the TI product(s) identified in such TI Resource. NO OTHER LICENSE, EXPRESS OR IMPLIED, BY ESTOPPEL OR OTHERWISE TO ANY OTHER TI INTELLECTUAL PROPERTY RIGHT, AND NO LICENSE TO ANY TECHNOLOGY OR INTELLECTUAL PROPERTY RIGHT OF TI OR ANY THIRD PARTY IS GRANTED HEREIN, including but not limited to any patent right, copyright, mask work right, or other intellectual property right relating to any combination, machine, or process in which TI products or services are used. Information regarding or referencing third-party products or services does not constitute a license to use such products or services, or a warranty or endorsement thereof. Use of TI Resources may require a license from a third party under the patents or other intellectual property of the third party, or a license from TI under the patents or other intellectual property of TI.

TI RESOURCES ARE PROVIDED "AS IS" AND WITH ALL FAULTS. TI DISCLAIMS ALL OTHER WARRANTIES OR REPRESENTATIONS, EXPRESS OR IMPLIED, REGARDING RESOURCES OR USE THEREOF, INCLUDING BUT NOT LIMITED TO ACCURACY OR COMPLETENESS, TITLE, ANY EPIDEMIC FAILURE WARRANTY AND ANY IMPLIED WARRANTIES OF MERCHANTABILITY, FITNESS FOR A PARTICULAR PURPOSE, AND NON-INFRINGEMENT OF ANY THIRD PARTY INTELLECTUAL PROPERTY RIGHTS. TI SHALL NOT BE LIABLE FOR AND SHALL NOT DEFEND OR INDEMNIFY DESIGNER AGAINST ANY CLAIM, INCLUDING BUT NOT LIMITED TO ANY INFRINGEMENT CLAIM THAT RELATES TO OR IS BASED ON ANY COMBINATION OF PRODUCTS EVEN IF DESCRIBED IN TI RESOURCES OR OTHERWISE. IN NO EVENT SHALL TI BE LIABLE FOR ANY ACTUAL, DIRECT, SPECIAL, COLLATERAL, INDIRECT, PUNITIVE, INCIDENTAL, CONSEQUENTIAL OR EXEMPLARY DAMAGES IN CONNECTION WITH OR ARISING OUT OF TI RESOURCES OR USE THEREOF, AND REGARDLESS OF WHETHER TI HAS BEEN ADVISED OF THE POSSIBILITY OF SUCH DAMAGES.

Unless TI has explicitly designated an individual product as meeting the requirements of a particular industry standard (e.g., ISO/TS 16949 and ISO 26262), TI is not responsible for any failure to meet such industry standard requirements.

Where TI specifically promotes products as facilitating functional safety or as compliant with industry functional safety standards, such products are intended to help enable customers to design and create their own applications that meet applicable functional safety standards and requirements. Using products in an application does not by itself establish any safety features in the application. Designers must ensure compliance with safety-related requirements and standards applicable to their applications. Designer may not use any TI products in life-critical medical equipment unless authorized officers of the parties have executed a special contract specifically governing such use. Life-critical medical equipment is medical equipment where failure of such equipment would cause serious bodily injury or death (e.g., life support, pacemakers, defibrillators, heart pumps, neurostimulators, and implantables). Such equipment includes, without limitation, all medical devices identified by the U.S. Food and Drug Administration as Class III devices and equivalent classifications outside the U.S.

TI may expressly designate certain products as completing a particular qualification (e.g., Q100, Military Grade, or Enhanced Product). Designers agree that it has the necessary expertise to select the product with the appropriate qualification designation for their applications and that proper product selection is at Designers' own risk. Designers are solely responsible for compliance with all legal and regulatory requirements in connection with such selection.

Designer will fully indemnify TI and its representatives against any damages, costs, losses, and/or liabilities arising out of Designer's non-compliance with the terms and provisions of this Notice.

Looking for pricing, stock, or lifecycle information?

Click below to explore more details on WIN SOURCE:

 [View TPS3818G25DRVR on WIN SOURCE](#)

 [Texas Instruments](#) Information

Optimize Your Supply Chain with WIN SOURCE Solutions

-  Global Sourcing Solution
-  Obsolete Management
-  Cost Control Management
-  Shortage Management
-  Alternative Solution
-  Excess Inventory Management