



2.5V/3.3V TWO INPUT, 1GHz LVTTTL/CMOS-TO-LVPECL 1:4 FANOUT BUFFER/TRANSLATOR WITH 2:1 INPUT MUX

**Precision Edge®
SY89834U**

FEATURES

- Selects between two LVTTTL/CMOS inputs and provides 4 LVPECL output copies
- Guaranteed AC performance over temperature and voltage:
 - DC-to >1.0GHz throughput
 - <500ps propagation delay (IN-to-Q)
 - < 20ps within-device skew
 - < 225ps rise/fall time
- Ultra-low jitter design:
 - < 1ps_{RMS} cycle-to-cycle jitter
 - < 1ps_{RMS} random jitter
 - < 10ps_{PP} deterministic jitter
 - < 10ps_{PP} total jitter (clock)
- Low voltage 2.5V and 3.3V supply operation
- 100K LVPECL outputs
- Industrial temperature range: -40°C to +85°C
- Includes a 2:1 MUX select input
- Accepts single-ended TTL/CMOS inputs and provides four LVPECL outputs
- Available in 16-pin (3mm x 3mm) MLF™ package

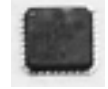

Precision Edge®

DESCRIPTION

The SY89834U is a high-speed, 1GHz LVTTTL/CMOS-to-LVPECL fanout buffer/translator optimized for high-speed ultra-low skew applications. The input stage is designed to accept two single-ended LVTTTL/CMOS compatible signals that feed into a 2:1 MUX. The selected input is translated and distributed as four differential 100K LVPECL outputs. Within device skew is guaranteed to be less than 20ps over supply voltage and temperature.

The single-ended input buffers accept TTL/CMOS logic levels. The internal threshold of the buffers is defined as $V_{CC}/2$.

The SY89834U is a part of Micrel's high-speed Precision Edge® family. For applications that require a different I/O combination, consult Micrel's website at: www.micrel.com, and choose from a comprehensive product line of high-speed, low-skew fanout buffers, translators and clock generators.

APPLICATIONS

- Processor clock distribution/translation
- SONET clock distribution/translation
- Fibre Channel clock distribution/translation
- Gigabit Ethernet clock distribution/translation
- Single-ended ASIC-to-differential communication IC signal translation

FUNCTIONAL BLOCK DIAGRAM

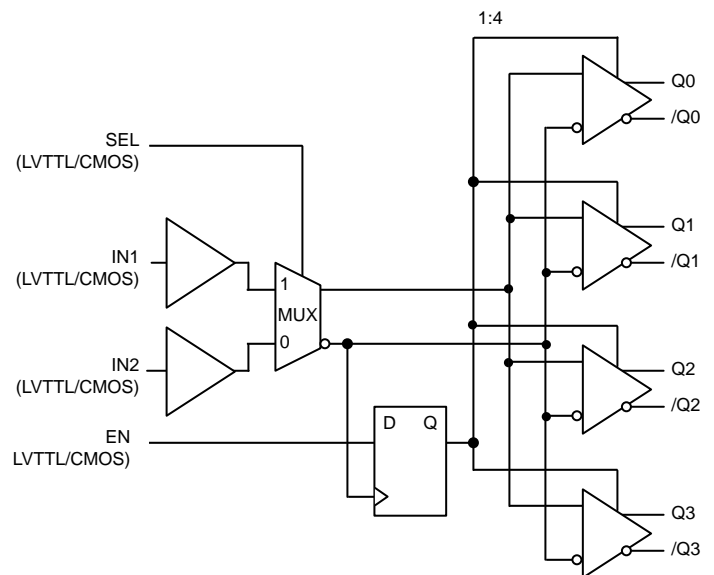

Precision Edge is a registered trademark of Micrel, Inc.
MicroLeadFrame and MLF are trademarks of Amkor Technology, Inc.

Absolute Maximum Ratings⁽¹⁾

Supply Voltage (V_{CC})	-0.5V to +4.0V
Input Voltage (V_{IN})	-0.5V to $V_{CC} + 0.3V$
LVPECL Output Current (I_{OUT})	
Continuous	50mA
Surge	100mA
Input Current (IN1, IN2)	$\pm 50mA$
Lead Temperature (Soldering, 20sec.)	260°C
Storage Temperature (T_S)	-65°C to +150°C

Operating Ratings⁽²⁾

Supply Voltage Range	+2.375V to +2.625V
	+3.0V to +3.6V
Ambient Temperature (T_A)	-40°C to +85°C
Package Thermal Resistance ⁽³⁾	
MLF™ (θ_{JA})	
Still-Air	60°C/W
MLF™ (Ψ_{JB})	
Junction-to-Board	32°C/W

DC ELECTRICAL CHARACTERISTICS⁽⁴⁾

$T_A = -40^\circ\text{C}$ to $+85^\circ\text{C}$, unless otherwise stated.

Symbol	Parameter	Condition	Min	Typ	Max	Units
V_{CC}	Power Supply		2.375		2.625	V
			3.0		3.6	V
I_{CC}	Power Supply Current	No load, max. V_{CC} .		50	75	mA

LVTTL/CMOS INPUTS DC ELECTRICAL CHARACTERISTICS⁽⁴⁾

$V_{CC} = 2.5V \pm 5\%$ or $V_{CC} = 3.3V \pm 10\%$; $T_A = -40^\circ\text{C}$ to $+85^\circ\text{C}$, unless otherwise stated.

Symbol	Parameter	Condition	Min	Typ	Max	Units
V_{IH}	Input HIGH Voltage		2.0			V
V_{IL}	Input LOW Voltage				0.8	V
I_{IH}	Input HIGH Current	$I_{IH} @ V_{IN} = 2.7V$	-125		30	μA
I_{IL}	Input LOW Current		-125			μA

(100KEP) LVPECL OUTPUTS DC ELECTRICAL CHARACTERISTICS⁽⁴⁾

$V_{CC} = 2.5V \pm 5\%$ or $V_{CC} = 3.3V \pm 10\%$, $R_L = 50\Omega$ to $V_{CC} - 2V$; $T_A = -40^\circ\text{C}$ to $+85^\circ\text{C}$, unless otherwise stated.

Symbol	Parameter	Condition	Min	Typ	Max	Units
V_{OH}	Output HIGH Voltage		$V_{CC} - 1.145$	$V_{CC} - 1.020$	$V_{CC} - 0.895$	V
V_{OL}	Output LOW Voltage		$V_{CC} - 1.945$	$V_{CC} - 1.820$	$V_{CC} - 1.695$	V
V_{OUT}	Output Voltage Swing	See Figures 2a.	550	800	1050	mV
V_{DIFF_OUT}	Differential Output Voltage Swing	See Figures 2b.	1100	1600	2100	mV

Notes:

1. Permanent device damage may occur if absolute maximum ratings are exceeded. This is a stress rating only and functional operation is not implied at conditions other than those detailed in the operational sections of this data sheet. Exposure to absolute maximum rating conditions for extended periods may affect device reliability.
2. The data sheet limits are not guaranteed if the device is operated beyond the operating ratings.
3. Junction-to-board resistance assumes exposed pad is soldered (or equivalent) to the device's most negative potential on the PCB. θ_{JA} and Ψ_{JB} values are determined for a 4-layer board in still-air, unless otherwise stated.
4. The circuit is designed to meet the DC specifications shown in the above table after thermal equilibrium has been established.

AC ELECTRICAL CHARACTERISTICS⁽⁵⁾

$V_{CC} = 2.5V \pm 5\%$ or $V_{CC} = 3.3V \pm 10\%$, $R_L = 50\Omega$ to $V_{CC} - 2V$; $T_A = -40^\circ C$ to $+85^\circ C$, unless otherwise stated.

Symbol	Parameter	Condition	Min	Typ	Max	Units
f_{MAX}	Maximum Frequency	Input $t_r / t_f \geq 350ps$	1.0			GHz
t_{pd}	Propagation Delay IN-to-Q	Note 6	200	320	500	ps
t_{SW}	Switchover Time SEL-to-Q		200	320	500	ps
t_{SKEW}	Within-Device Skew	Note 7		5	20	ps
	Part-to-Part Skew	Note 8			300	ps
t_{JITTER}	Data Random Jitter (RJ) Deterministic Jitter (DJ)	Note 9 Note 10			1 10	ps_{RMS} ps_{PP}
	Clock Cycle-to-Cycle Jitter Total Jitter (TJ)	Note 11 Note 12			1 10	ps_{RMS} ps_{PP}
DC	Duty Cycle	Input $t_r/t_f \geq 350ps$, Note 13	45	50	55	%
t_S	Set-Up Time EN to IN1, IN	Note 14 and Note 15	300			ps
t_H	Hold Time EN to IN1, IN	Note 14 and Note 15	500			ps
t_r, t_f	Output Rise/Fall Times (20% to 80%)		70	140	225	ps

Notes:

- High-frequency AC parameters are guaranteed by design and characterization.
- $V_{IH} = 2.0V$, $V_{IL} = 0.8V$, 50% duty cycle. Delay measured at 100MHz from the crossing of the input signal with $V_{CC}/2$ as the crossing of the differential output signal. See Figure 1.
- Within device skew is measured between two different outputs under identical input transitions.
- Part-to-part skew is defined for two parts with identical power supply voltages at the same temperature and no skew at the edges at the respective inputs.
- Random jitter is measured with a K28.7 pattern, measured at $\leq f_{MAX}$.
- Deterministic jitter is measured at 2.5Gbps with both K28.5 and $2^{23}-1$ PRBS pattern.
- Cycle-to-cycle jitter definition: The variation period between adjacent cycles over a random sample of adjacent cycle pairs. $T_{JITTER_CC} = T_n - T_{n+1}$, where T is the time between rising edges of the output signal.
- Total jitter definition: with an ideal clock input frequency of $\leq f_{MAX}$ (device), no more than one output edge in 10^{12} output edges will deviate by more than the specified peak-to-peak jitter value.
- If t_r/t_f is less than 350ps, the duty cycle distortion will increase beyond the duty cycle limits.
- Set-up and hold times apply to synchronous applications that intend to enable/disable before the next clock cycle. For asynchronous applications set-up and hold times do not apply.
- See "Timing Diagrams," Figure 1a.

TIMING DIAGRAMS

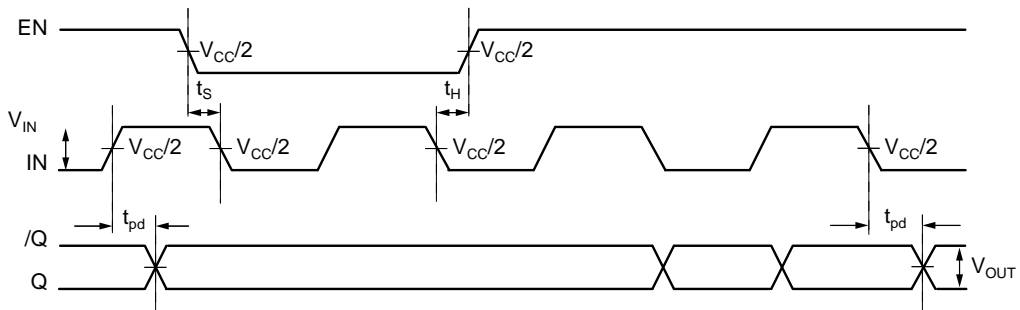

Figure 1a. Timing Diagram (EN, IN1, IN2)

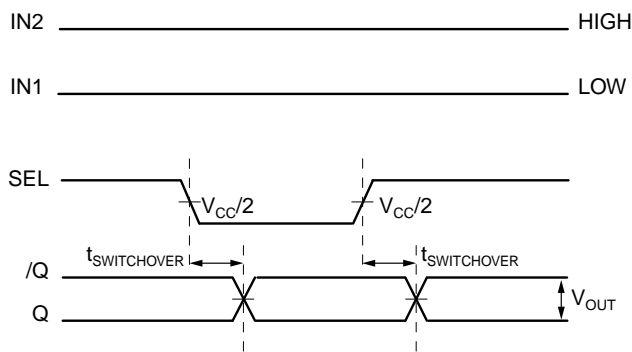

Figure 1b. Timing Diagram (SEL)

SINGLE-ENDED AND DIFFERENTIAL SWINGS

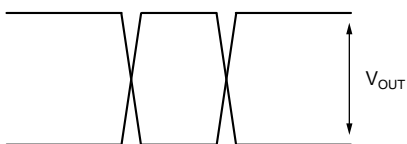

Figure 2a. Single-Ended Swing

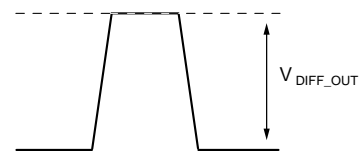
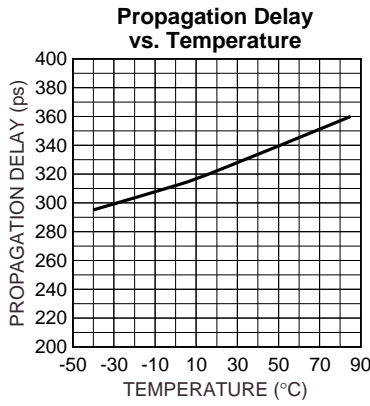
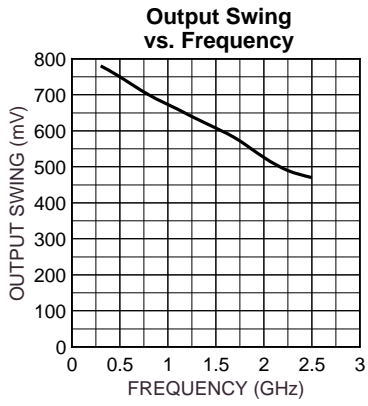

Figure 2b. Differential Swing

TYPICAL OPERATING CHARACTERISTICS

$V_{CC} = 3.3V$, $GND = 0V$, $R_L = 50\Omega$ to $V_{CC} - 2V$; $T_A = 25^\circ C$, unless otherwise stated.



FUNCTIONAL CHARACTERISTICS

$V_{CC} = 3.3V$, $GND = 0V$, $R_L = 50\Omega$ to $V_{CC} - 2V$, $T_A = 25^\circ C$, unless otherwise stated.

155MHz Output

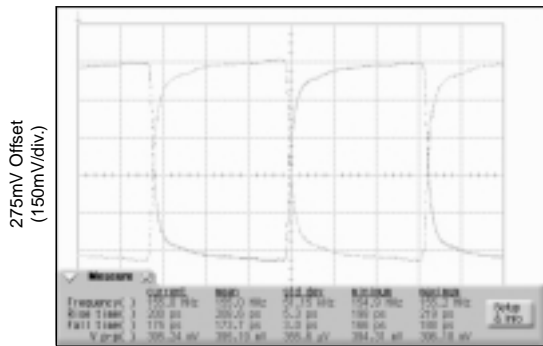

TIME (1ns/div.)

622MHz Output

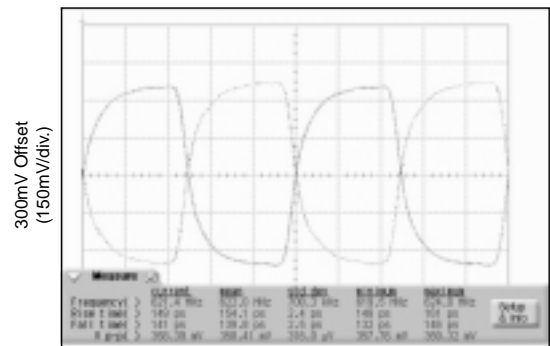

TIME (321.9ps/div.)

1GHz Output

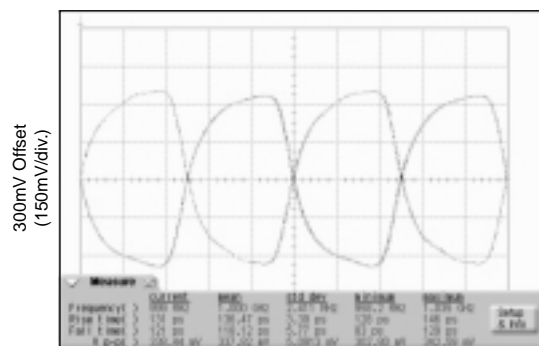

TIME (200ps/div.)

DIFFERENTIAL INPUT

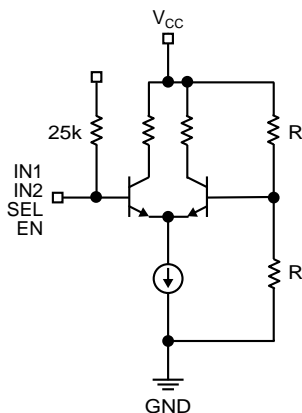

Figure 3. Simplified TTL/CMOS Input Buffer

RELATED PRODUCTS AND SUPPORT DOCUMENTATION

Part Number	Function	Data Sheet Link
SY89830U	2.5V/3.3V/5V 2.5GHz 1:4 PECL/ECL Clock Driver with 2:1 Differential Input Mux	http://www.micrel.com/product-info/products/sy89830u.shtml
SY89831U	Ultra-Precision 1:4 LVPECL Fanout Buffer/Translator with Internal Termination	http://www.micrel.com/product-info/products/sy89831u.shtml
SY89832U	2.5V Ultra-Precision 1:4 LVDS Fanout Buffer/Translator with Internal Termination	http://www.micrel.com/product-info/products/sy89832u.shtml
SY89833U	3.3V Ultra-Precision 1:4 LVDS Fanout Buffer/Translator with Internal Termination	http://www.micrel.com/product-info/products/sy89833u.shtml
	16-MLF™ Manufacturing Guidelines Exposed Pad Application Note	http://www.amkor.com/products/notes-papers/MLF-appnote-0301.pdf
HBW Solutions	New Products + Termination App Note	http://www.micrel.com/product-info/as/solutions.shtml

TERMINATION RECOMMENDATIONS

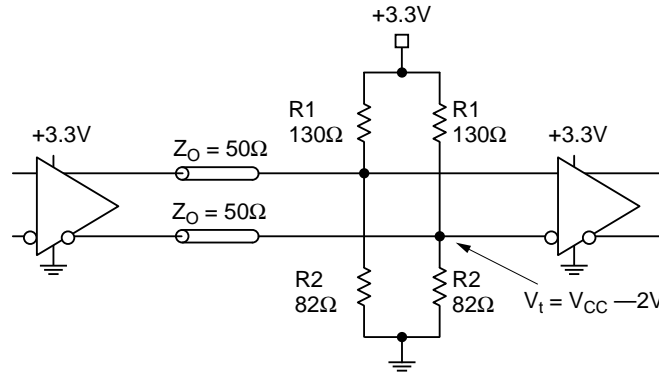

Figure 4a. Parallel Termination-Thevenin Equivalent

Note:

- 1. For +2.5V systems: R1 = 250Ω, R2 = 62.5Ω
- For +3.3V systems: R1 = 130Ω, R2 = 82Ω

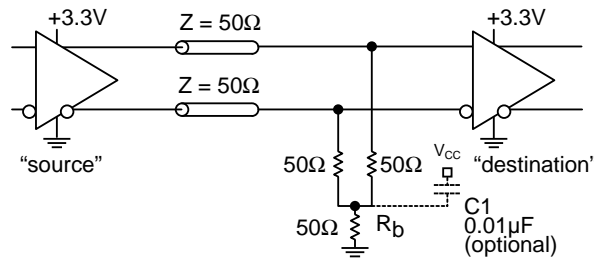

Figure 4b. Three-Resistor "Y-Termination"

Notes:

- 1. Power-saving alternative to Thevenin termination.
- 2. Place termination resistors as close to destination inputs as possible.
- 3. R_b resistor sets the DC bias voltage, equal to V_t. For +3.3V systems R_b = 50Ω. For +2.5V systems R_b = 19Ω.

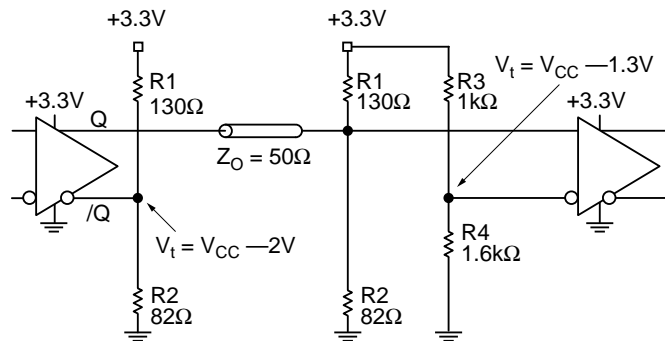
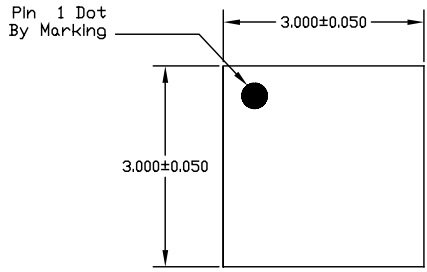

Figure 4c. Terminating Unused LVPECL I/O

Notes:

- 1. Unused output (/Q) must be terminated to balance the output.
- 2. For +2.5V systems: R1 = 250Ω, R2 = 62.5Ω, R3 = 1.25kΩ, R4 = 1.2kΩ.
- 2. Unused output pairs (Q and /Q) may be left floating.

16 LEAD EPAD *MicroLeadFrame*™ (MLF-16)



TOP VIEW

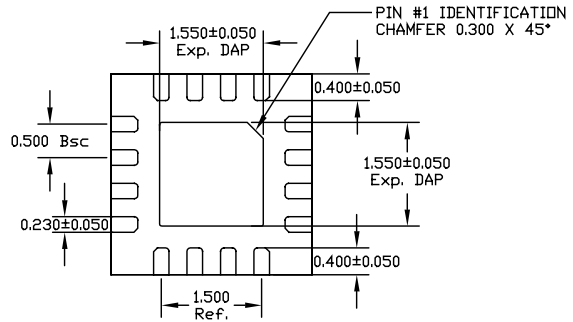

BOTTOM VIEW

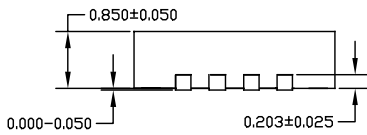

SIDE VIEW

- NOTE:
1. ALL DIMENSIONS ARE IN MILLIMETERS.
 2. MAX. PACKAGE WARPAGE IS 0.05 mm.
 3. MAXIMUM ALLOWABLE BURRS IS 0.076 mm IN ALL DIRECTIONS.
 4. PIN #1 ID ON TOP WILL BE LASER/INK MARKED.

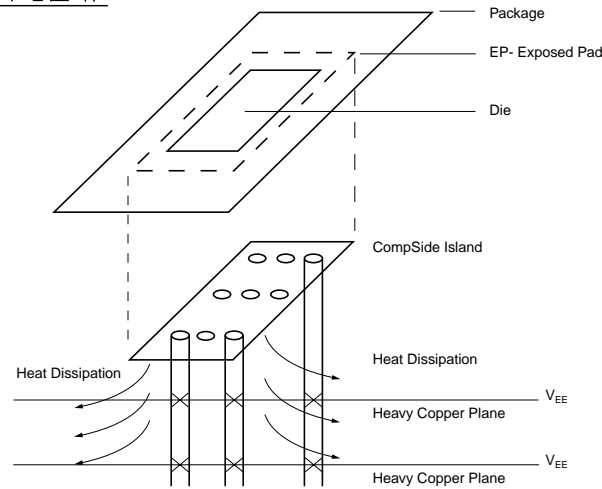

**PCB Thermal Consideration for 16-Pin MLF™ Package
(Always solder, or equivalent, the exposed pad to the PCB.)**

Package Notes:

- Note 1.** Package meets Level 2 moisture sensitivity classification, and are shipped in dry-pack form.
- Note 2.** Exposed pads must be soldered to a ground for proper thermal management.

MICREL, INC. 2180 FORTUNE DRIVE SAN JOSE, CA 95131 USA

TEL + 1 (408) 944-0800 FAX + 1 (408) 474-1000 WEB <http://www.micrel.com>

The information furnished by Micrel in this datasheet is believed to be accurate and reliable. However, no responsibility is assumed by Micrel for its use. Micrel reserves the right to change circuitry and specifications at any time without notification to the customer.

Micrel Products are not designed or authorized for use as components in life support appliances, devices or systems where malfunction of a product can reasonably be expected to result in personal injury. Life support devices or systems are devices or systems that (a) are intended for surgical implant into the body or (b) support or sustain life, and whose failure to perform can be reasonably expected to result in a significant injury to the user. A Purchaser's use or sale of Micrel Products for use in life support appliances, devices or systems is at Purchaser's own risk and Purchaser agrees to fully indemnify Micrel for any damages resulting from such use or sale.

Looking for pricing, stock, or lifecycle information?

Click below to explore more details on WIN SOURCE:

- ⊖ [View SY89834UMI on WIN SOURCE](#)
- ⊖ [Microchip Technology Information](#)

Optimize Your Supply Chain with WIN SOURCE Solutions

- ✓ Global Sourcing Solution
- ✓ Obsolete Management
- ✓ Cost Control Management
- ✓ Shortage Management
- ✓ Alternative Solution
- ✓ Excess Inventory Management