



THE DATASHEET OF VND5E025AY-E



Double channel high-side driver with analog current sense for automotive applications

Datasheet – production data

Features

Max transient supply voltage	V_{CC}	41V
Operating voltage range	V_{CC}	4.5 V to 28 V
Typ on-state resistance (per ch.)	R_{ON}	25 m Ω
Current limitation (typ)	I_{LIMH}	47 A
Off state supply current	I_S	2 μ A ⁽¹⁾

1. Typical value with all loads connected.

- General
 - Very low standby current
 - 3 V CMOS compatible inputs
 - Optimized electromagnetic emissions
 - Very low electromagnetic susceptibility
 - Compliance with European directive 2002/95/EC
 - Very low current sense leakage
- Diagnostic functions
 - Proportional load current sense
 - OFF-state open-load detection
 - Current sense disable
 - Thermal shutdown indication
 - Output short to V_{CC} detection
 - Over load and short to ground (power limitation) indication
- Protection
 - Undervoltage shutdown
 - Over voltage clamp
 - Load current limitation
 - Self limiting of fast thermal transients
 - Protection against loss of ground and loss of V_{CC}
 - Over temperature shutdown with autorestart (thermal shutdown)
 - Reverse battery protection with self switch on of the Power MOSFET
 - Electrostatic discharge protection



- Inrush current active management by power limitation

Applications

- All types of resistive, inductive and capacitive loads

Description

The VND5E025AY-E is a double-channel high-side driver manufactured using STMicroelectronics® proprietary VIPower® M0-5 technology and housed in PowerSSO-36 package. The VND5E025AY-E is designed to drive 12 V automotive grounded loads, and to provide protection and diagnostics. It also implements a 3 V and 5 V CMOS-compatible interface for use with any microcontroller.

The device integrates advanced protective functions such as load current limitation, inrush and overload active management by power limitation, overtemperature shut-off with auto-restart and overvoltage active clamp.

A dedicated analog current sense pin is associated with every output channel providing enhanced diagnostic functions including fast detection of overload and short-circuit to ground through power limitation indication, overtemperature indication, short-circuit to V_{CC} diagnosis.

The current sensing and diagnostic feedback of the whole device can be disabled by pulling the CS_DIS pin high to share the external sense resistor with similar devices.

Contents

1	Block diagram and pin description	5
2	Electrical specifications	7
2.1	Absolute maximum ratings	7
2.2	Thermal data	8
2.3	Electrical characteristics	9
2.4	Waveforms	18
2.5	Electrical characteristics curves	21
3	Application information	24
3.1	Load dump protection	24
3.2	MCU I/Os protection	24
3.3	Current sense and diagnostic	25
3.3.1	Short to V_{CC} and off-state open-load detection	26
3.4	Maximum demagnetization energy ($V_{CC} = 13.5\text{ V}$)	28
4	Package and PCB thermal data	29
4.1	PowerSSO-36 thermal data	29
5	Package information	32
5.1	ECOPACK®	32
5.2	PowerSSO-36 mechanical data	32
5.3	Packing information	34
6	Device summary	35
7	Revision history	36

List of tables

Table 1.	Pin function	5
Table 2.	Suggested connections for unused and not connected pins	6
Table 3.	Absolute maximum ratings	7
Table 4.	Thermal data	8
Table 5.	Power section	9
Table 6.	Switching ($V_{CC} = 13\text{ V}$; $T_j = 25\text{ }^\circ\text{C}$)	9
Table 7.	Current sense ($8\text{ V} < V_{CC} < 18\text{ V}$)	10
Table 8.	Open-load detection ($8\text{ V} < V_{CC} < 18\text{ V}$)	11
Table 9.	Protections and diagnostics	11
Table 10.	Logic inputs	12
Table 11.	Truth table	16
Table 12.	Electrical transient requirements (part 1)	17
Table 13.	Electrical transient requirements (part 2)	17
Table 14.	Electrical transient requirements (part 3)	17
Table 15.	Thermal parameters	31
Table 16.	PowerSSO-36 mechanical data	33
Table 17.	Device summary	35
Table 18.	Document revision history	36

List of figures

Figure 1.	Block diagram	5
Figure 2.	Configuration diagram (top view)	6
Figure 3.	Current and voltage conventions	7
Figure 4.	Current sense delay characteristics	13
Figure 5.	Open-load off-state delay timing	13
Figure 6.	Switching characteristics	13
Figure 7.	Delay response time between rising edge of output current and rising edge of current sense (CS enabled) ¹⁴	
Figure 8.	Output voltage drop limitation	14
Figure 9.	I_{OUT}/I_{SENSE} vs I_{OUT}	15
Figure 10.	Maximum current sense ratio drift vs load current	15
Figure 11.	Normal operation	18
Figure 12.	Overload or short to GND	18
Figure 13.	Intermittent overload	19
Figure 14.	Short to V_{CC}	19
Figure 15.	T_J evolution in overload or short to GND	20
Figure 16.	Off-state output current	21
Figure 17.	High-level input current	21
Figure 18.	Input clamp voltage	21
Figure 19.	High-level input voltage	21
Figure 20.	Low-level input voltage	21
Figure 21.	Input hysteresis voltage	21
Figure 22.	On-state resistance vs T_{case}	22
Figure 23.	On-state resistance vs V_{CC}	22
Figure 24.	Undervoltage shutdown	22
Figure 25.	I_{LIMH} vs T_{case}	22
Figure 26.	Turn-on voltage slope	22
Figure 27.	Turn-off voltage slope	22
Figure 28.	CS_DIS clamp voltage	23
Figure 29.	Low-level CS_DIS voltage	23
Figure 30.	High-level CS_DIS voltage	23
Figure 31.	Application schematic	24
Figure 32.	Current sense and diagnostic	26
Figure 33.	Maximum turn off current versus inductance	28
Figure 34.	PowerSSO-36 PC board	29
Figure 35.	$R_{thj-amb}$ vs PCB copper area in open box free air condition (one channel on)	30
Figure 36.	PowerSSO-36 thermal impedance junction ambient single pulse (one channel on)	30
Figure 37.	Thermal fitting model of a double-channel HSD in PowerSSO-36	31
Figure 38.	PowerSSO-36 package dimensions	32
Figure 39.	PowerSSO-36 tube shipment (no suffix)	34
Figure 40.	PowerSSO-36 tape and reel shipment (suffix "TR")	34

1 Block diagram and pin description

Figure 1. Block diagram

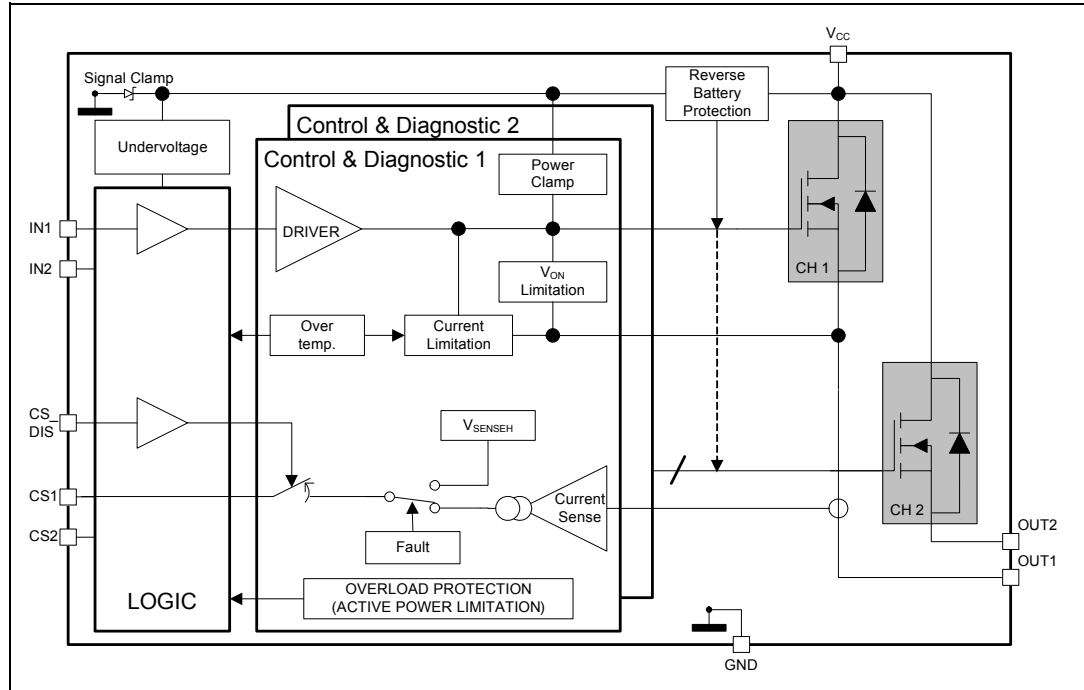

Table 1. Pin function

Name	Function
V _{CC}	Battery connection
OUT _{1,2}	Power output
GND	Ground connection
IN _{1,2}	Voltage controlled input pins with hysteresis, CMOS compatible. They controls output switch state
CS _{1,2}	Analog current sense pins, they deliver a current proportional to the load current
CS_DIS	Active high CMOS compatible pin, to disable the current sense pin

Figure 2. Configuration diagram (top view)

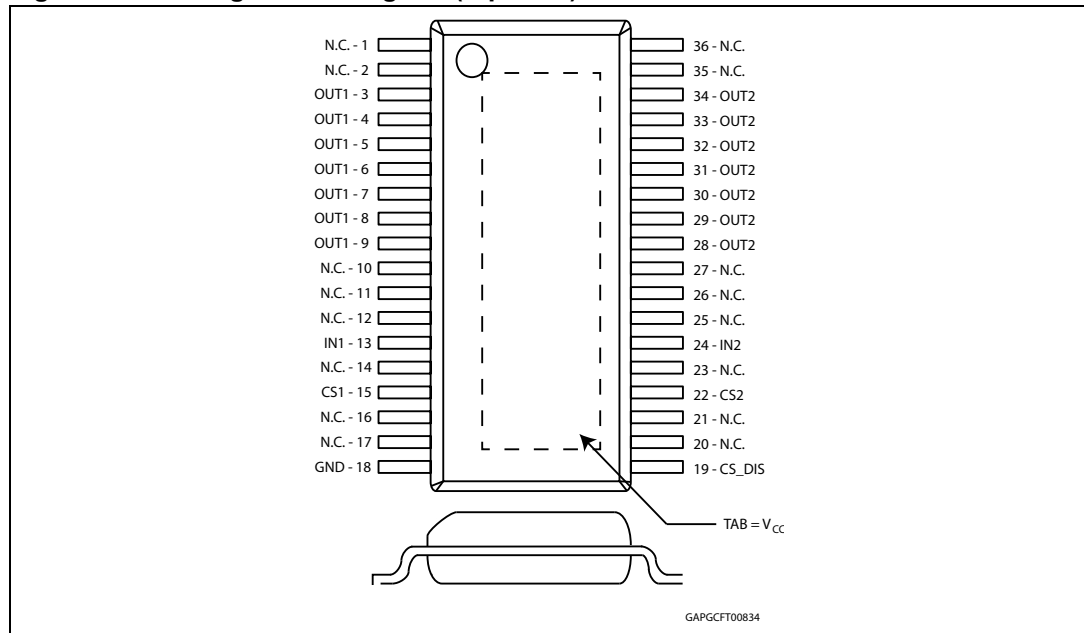

Table 2. Suggested connections for unused and not connected pins

Connection / pin	Current sense	N.C.	Output	Input	CS_DIS
Floating	Not allowed	X ⁽¹⁾	X	X	X
To ground	Through 1 KΩ resistor	X	Not allowed	Through 10 KΩ resistor	Through 10 KΩ resistor

1. X: do not care.

2 Electrical specifications

Figure 3. Current and voltage conventions

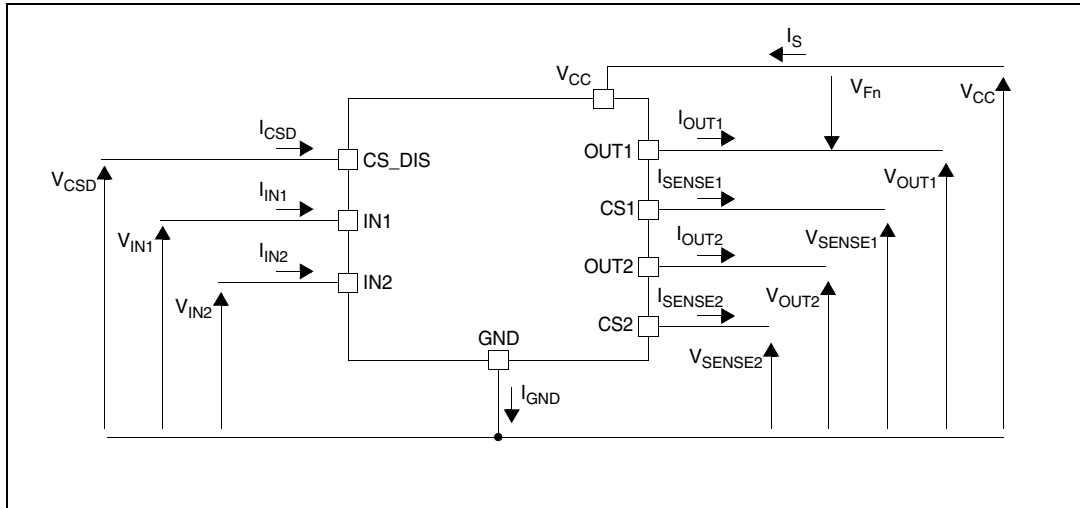

2.1 Absolute maximum ratings

Stressing the device above the rating listed in the [Table 3](#) may cause permanent damage to the device. These are stress ratings only and operation of the device at these or any other conditions above those indicated in the operating sections of this specification is not implied. Exposure to the conditions in table below for extended periods may affect device reliability.

Table 3. Absolute maximum ratings

Symbol	Parameter	Value	Unit
V_{CC}	DC supply voltage	41	V
$-V_{CC}$	Reverse DC supply voltage	16	V
V_{CC_LSC}	Maximum supply voltage for full protection to short-circuit (AEC-Q100-012)	18	V
I_{OUT}	DC output current	Internally limited	A
$-I_{OUT}$	Reverse DC output current	35	A
I_{IN}	DC input current	-1 to 10	mA
I_{CSD}	DC current sense disable input current	-1 to 10	mA
$V_{CSSENSE}$	Current sense maximum voltage	$V_{CC} - 41$ $+V_{CC}$	V V
E_{MAX}	Maximum switching energy (single pulse) ($L = 0.26$ mH; $R_L = 0$ Ω ; $V_{BAT} = 13.5$ V; $T_{jstart} = 150^\circ\text{C}$; $I_{OUT} = I_{limL}(Typ.)$)	29	mJ

Table 3. Absolute maximum ratings (continued)

Symbol	Parameter	Value	Unit
V _{ESD}	Electrostatic discharge (human body model: R = 1.5 KΩ; C = 100 pF)		
	– IN	4000	V
	– CS	2000	
	– CS_DIS	4000	
	– OUT	5000	
– V _{CC}	5000		
V _{ESD}	Charge device model (CDM-AEC-Q100-011)	750	V
T _j	Junction operating temperature	-40 to 150	°C
T _{stg}	Storage temperature	-55 to 150	°C

2.2 Thermal data

Table 4. Thermal data

Symbol	Parameter	Maximum value	Unit
R _{thj-case}	Thermal resistance junction-case (with one channel on)	1.4	°C/W
R _{thj-amb}	Thermal resistance junction-ambient (MAX)	See Figure 35 in the thermal section	°C/W

2.3 Electrical characteristics

Values specified in this section are for $8\text{ V} < V_{CC} < 28\text{ V}$; $-40^\circ\text{C} < T_j < 150^\circ\text{C}$, unless otherwise specified.

Table 5. Power section

Symbol	Parameter	Test conditions	Min.	Typ.	Max.	Unit
V_{CC}	Operating supply voltage		4.5	13	28	V
V_{USD}	Undervoltage shutdown			3.5	4.5	V
$V_{USDhyst}$	Undervoltage shutdown hysteresis			0.5		V
R_{ON}	ON-state resistance	$I_{OUT} = 3\text{ A}$; $T_j = 25^\circ\text{C}$		25		m Ω
		$I_{OUT} = 3\text{ A}$; $T_j = 150^\circ\text{C}$			50	
		$I_{OUT} = 3\text{ A}$; $V_{CC} = 5\text{ V}$; $T_j = 25^\circ\text{C}$		35		
$R_{ON\ REV}$	Reverse battery ON-state resistance	$V_{CC} = -13\text{ V}$; $I_{OUT} = -3\text{ A}$; $T_j = 25^\circ\text{C}$		25		m Ω
V_{clamp}	Clamp voltage	$I_S = 20\text{ mA}$	41	46	52	V
I_S	Supply current	Off-state: $V_{CC} = 13\text{ V}$; $T_j = 25^\circ\text{C}$; $V_{IN} = V_{OUT} = V_{SENSE} = V_{CSD} = 0\text{ V}$		2 ⁽¹⁾	5 ⁽¹⁾	μA
		On-state: $V_{CC} = 13\text{ V}$; $V_{IN} = 5\text{ V}$; $I_{OUT} = 0\text{ A}$		3.5	6.5	mA
$I_{L(off)}$	OFF-state output current ⁽²⁾	$V_{IN} = V_{OUT} = 0\text{ V}$; $V_{CC} = 13\text{ V}$; $T_j = 25^\circ\text{C}$	0	0.01	3	μA
		$V_{IN} = V_{OUT} = 0\text{ V}$; $V_{CC} = 13\text{ V}$; $T_j = 125^\circ\text{C}$	0		5	

1. PowerMOS leakage included.

2. For each channel.

Table 6. Switching ($V_{CC} = 13\text{ V}$; $T_j = 25^\circ\text{C}$)

Symbol	Parameter	Test conditions	Min.	Typ.	Max.	Unit
$t_{d(on)}$	Turn-on delay time	$R_L = 4.3\ \Omega$ (see Figure 6)	—	20	—	μs
$t_{d(off)}$	Turn-off delay time	$R_L = 4.3\ \Omega$ (see Figure 6)	—	20	—	μs
$(dV_{OUT}/dt)_{on}$	Turn-on voltage slope	$R_L = 4.3\ \Omega$	—	See Figure 26	—	V/ μs
$(dV_{OUT}/dt)_{off}$	Turn-off voltage slope	$R_L = 4.3\ \Omega$	—	See Figure 27	—	V/ μs
W_{ON}	Switching energy losses during t_{won}	$R_L = 4.3\ \Omega$ (see Figure 6)	—	0.25	—	mJ
W_{OFF}	Switching energy losses during t_{woff}	$R_L = 4.3\ \Omega$ (see Figure 6)	—	0.3	—	mJ

Table 7. Current sense (8 V < V_{CC} < 18 V)

Symbol	Parameter	Test conditions	Min.	Typ.	Max.	Unit
K ₀	I _{OUT} /I _{SENSE}	I _{OUT} = 0.5 A; V _{SENSE} = 0.5 V T _J = -40°C to 150°C	1000	2900	5000	
K ₁	I _{OUT} /I _{SENSE}	I _{OUT} = 2 A; V _{SENSE} = 0.5 V T _J = -40°C to 150°C T _J = 25°C to 150°C	1900 2240	3000 3000	3810 3520	
dK ₁ /K ₁ ⁽¹⁾	Current sense ratio drift	I _{OUT} = 2 A; V _{SENSE} = 0.5 V; V _{CSD} = 0 V; T _J = -40°C to 150°C	-9		9	%
K ₂	I _{OUT} /I _{SENSE}	I _{OUT} = 3 A; V _{SENSE} = 4 V T _J = -40 °C to 150 °C T _J = 25 °C to 150 °C	2230 2460	3000 3000	3550 3350	
dK ₂ /K ₂ ⁽¹⁾	Current sense ratio drift	I _{OUT} = 3 A; V _{SENSE} = 4 V; V _{CSD} = 0 V; T _J = -40°C to 150°C	-6		6	%
K ₃	I _{OUT} /I _{SENSE}	I _{OUT} = 10 A; V _{SENSE} = 4 V T _J = -40°C to 150°C T _J = 25°C to 150°C	2710 2780	2900 2900	3150 3080	
dK ₃ /K ₃ ⁽¹⁾	Current sense ratio drift	I _{OUT} = 10 A; V _{SENSE} = 4 V; V _{CSD} = 0 V; T _J = -40°C to 150°C	-3		3	%
I _{SENSE0}	Analog sense leakage current	I _{OUT} = 0 A; V _{SENSE} = 0 V; V _{CSD} = 5 V; V _{IN} = 0 V; T _J = -40°C to 150°C	0		1	μA
		I _{OUT} = 0 A; V _{SENSE} = 0 V; V _{CSD} = 0 V; V _{IN} = 5 V; T _J = -40°C to 150°C	0		2	
		I _{OUT} = 3 A; V _{SENSE} = 0 V; V _{CSD} = V _{IN} = 5 V;	0		1	
V _{SENSE}	Max analog sense output voltage	I _{OUT} = 15 A; V _{CSD} = 0 V	5			V
V _{SENSEH}	Analog sense output voltage in fault condition ⁽²⁾	V _{CC} = 13 V; R _{SENSE} = 10 KΩ		8		V
I _{SENSEH}	Analog sense output current in fault condition ⁽²⁾	V _{CC} = 13 V; V _{SENSE} = 5 V		9		mA
t _{DSSENSE1H}	Delay response time from falling edge of CS_DIS pin	V _{SENSE} < 4 V; 0.5 A < I _{OUT} < 10 A; I _{SENSE} = 90% of I _{SENSE max} (see Figure 4)		20	100	μs
t _{DSSENSE1L}	Delay response time from rising edge of CS_DIS pin	V _{SENSE} < 4 V; 0.5 A < I _{OUT} < 10 A; I _{SENSE} = 10 % of I _{SENSE max} (see Figure 4)		5	20	μs

Table 7. Current sense (8 V < V_{CC} < 18 V) (continued)

Symbol	Parameter	Test conditions	Min.	Typ.	Max.	Unit
t _{DSENSE2H}	Delay response time from rising edge of IN pin	V _{SENSE} < 4 V; 0.5 A < I _{OUT} < 10 A; I _{SENSE} = 90 % of I _{SENSE max} (see Figure 4)		70	300	μs
Δt _{DSENSE2H}	Delay response time between rising edge of output current and rising edge of current sense	V _{SENSE} < 4V; I _{SENSE} = 90 % of I _{SENSEMAX} , I _{OUT} = 90 % of I _{OUTMAX} I _{OUTMAX} = 3 A (see Figure 7)			100	μs
t _{DSENSE2L}	Delay response time from falling edge of IN pin	V _{SENSE} < 4 V; 0.5 A < I _{OUT} < 10 A; I _{SENSE} = 10 % of I _{SENSE max} (see Figure 4)		5	50	μs

1. Parameter guaranteed by design; it is not tested.
2. Fault condition includes: power limitation, overtemperature and open-load OFF-state detection.

Table 8. Open-load detection (8 V < V_{CC} < 18 V)

Symbol	Parameter	Test conditions	Min.	Typ.	Max.	Unit
V _{OL}	Open-load off-state voltage detection threshold	V _{IN} = 0 V; 8 V < V _{CC} < 18 V	2	—	4	V
I _{OL}	Open-load on-state current detection threshold	V _{IN} = 5 V; 8 V < V _{CC} < 18 V; I _{SENSE} = 5 μA		—	45	mA
t _{DSTKON}	Output short circuit to V _{CC} detection delay at turn off	See Figure 5	180	—	1200	μs
td_vol	Delay response from output rising edge to V _{SENSE} rising edge in open-load	V _{IN} = 0 V; V _{OUT} = 4 V; V _{SENSE} = 90 % of V _{SENSEH}		—	20	μs
I _{LOFF2}	Off-state output current	V _{OUT} = 4 V	-75	—	0	μA

Table 9. Protections and diagnostics⁽¹⁾

Symbol	Parameter	Test conditions	Min.	Typ.	Max.	Unit
I _{limH}	DC short-circuit current	V _{CC} = 13 V	33	47	66	A
		5 V < V _{CC} < 18 V			66	
I _{limL}	Short-circuit current during thermal cycling	V _{CC} = 13 V; T _R < T _j < T _{TSD}		12		A
T _{TSD}	Shutdown temperature		150	175	200	°C
T _R	Reset temperature		T _{RS} + 1	T _{RS} + 5		°C
T _{RS}	Thermal reset of status		135			°C

Table 9. Protections and diagnostics⁽¹⁾ (continued)

Symbol	Parameter	Test conditions	Min.	Typ.	Max.	Unit
T _{HYST}	Thermal hysteresis (T _{TSD} - T _R)			7		°C
V _{DEMAG}	Turn-off output voltage clamp	I _{OUT} = 2 A; V _{IN} = 0 V; L = 6 mH; T _j = -40°C	V _{CC} - 39	V _{CC} - 46	V _{CC} - 52	V
		I _{OUT} = 2 A; V _{IN} = 0; L = 6 mH; 25°C < T _j < 150°C	V _{CC} - 41	V _{CC} - 46	V _{CC} - 52	V
V _{ON}	Output voltage drop limitation	I _{OUT} = 0.1 A; T _j = -40°C to 150°C (see Figure 8)		25		mV

1. To ensure long term reliability under heavy overload or short-circuit conditions, protection and related diagnostic signals must be used together with a proper software strategy. If the device is subjected to abnormal conditions, this software must limit the duration and number of activation cycles.

Table 10. Logic inputs

Symbol	Parameter	Test conditions	Min.	Typ.	Max.	Unit
V _{IL}	Low-level input voltage				0.9	V
I _{IL}	Low-level input current	V _{IN} = 0.9 V	1			µA
V _{IH}	High-level input voltage		2.1			V
I _{IH}	High-level input current	V _{IN} = 2.1 V			10	µA
V _{I(hyst)}	Input hysteresis voltage		0.25			V
V _{ICL}	Input clamp voltage	I _{IN} = 1 mA	5.5		7	V
		I _{IN} = -1 mA		-0.7		
V _{CSDL}	Low-level CS_DIS voltage				0.9	V
I _{CSDL}	Low-level CS_DIS current	V _{CSD} = 0.9 V	1			µA
V _{CSDH}	High-level CS_DIS voltage		2.1			V
I _{CSDH}	High-level CS_DIS current	V _{CSD} = 2.1 V			10	µA
V _{CSD(hyst)}	CS_DIS hysteresis voltage		0.25			V
V _{CSCL}	CS_DIS clamp voltage	I _{CSD} = 1 mA	5.5		7	V
		I _{CSD} = -1 mA		-0.7		

Figure 4. Current sense delay characteristics

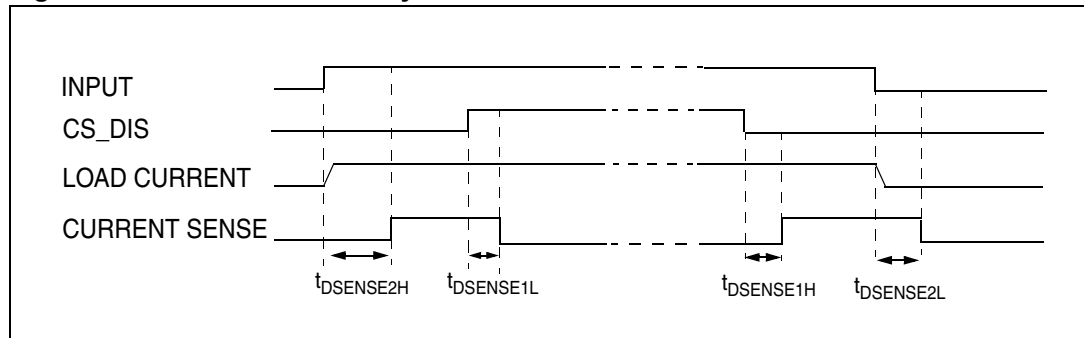

Figure 5. Open-load off-state delay timing

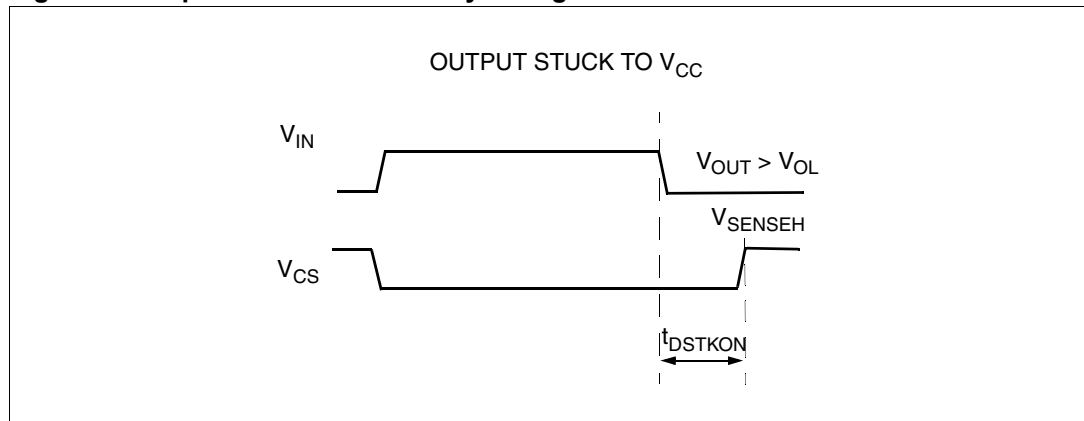

Figure 6. Switching characteristics

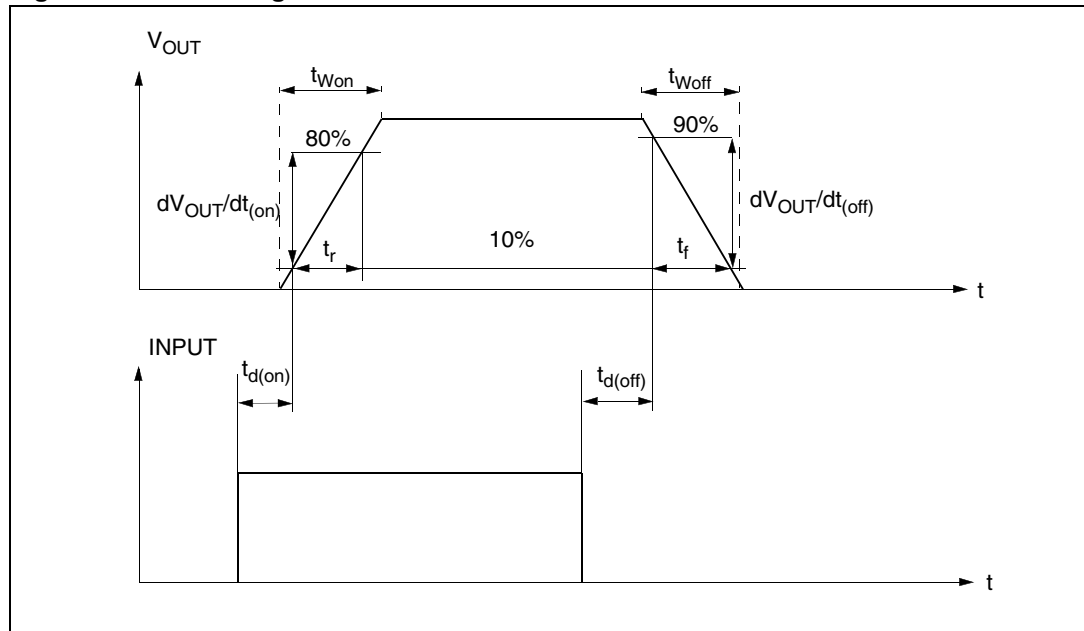

Figure 7. Delay response time between rising edge of output current and rising edge of current sense (CS enabled)

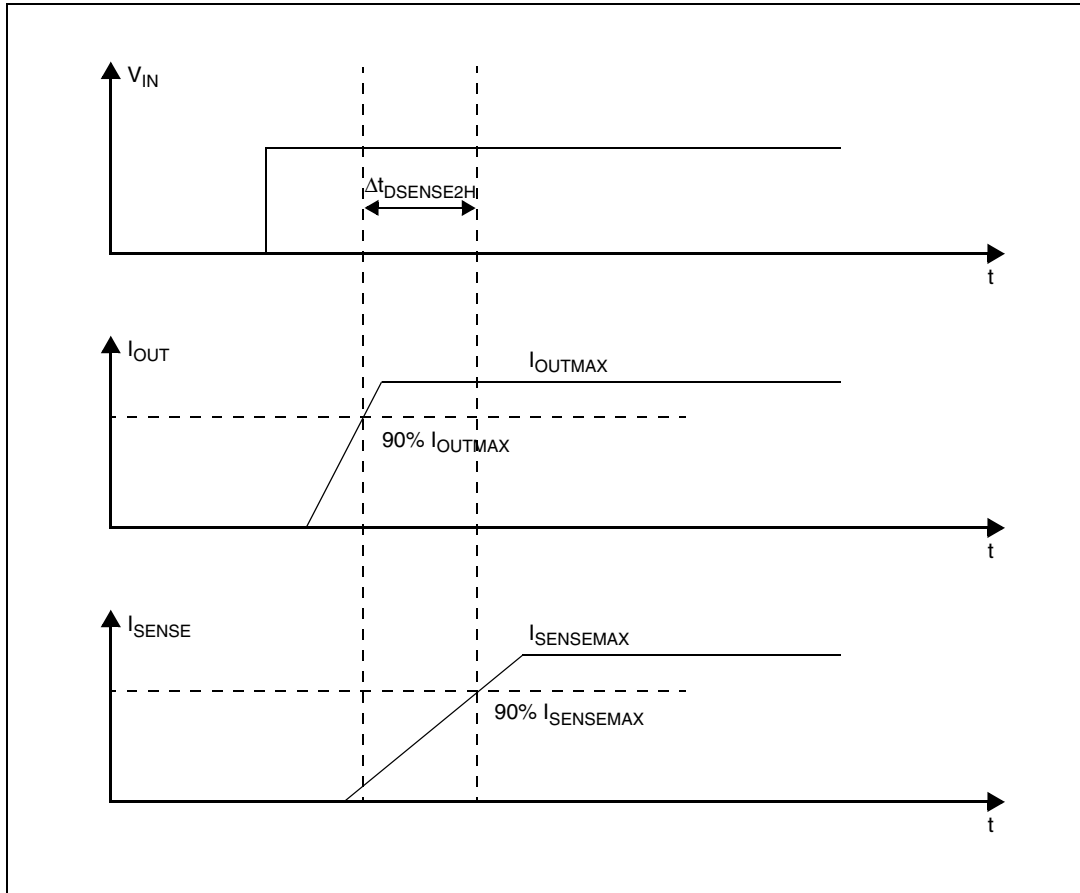

Figure 8. Output voltage drop limitation

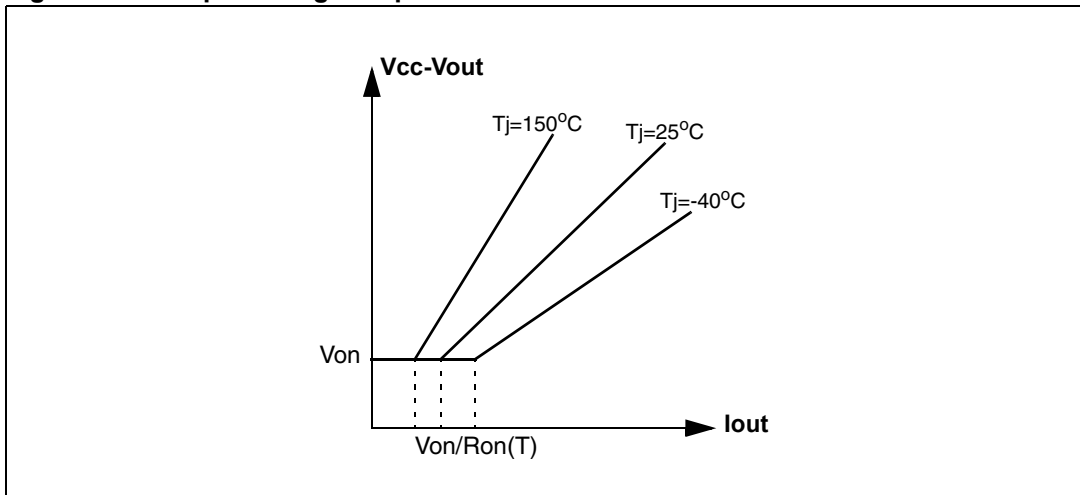

Figure 9. I_{OUT}/I_{SENSE} vs I_{OUT}

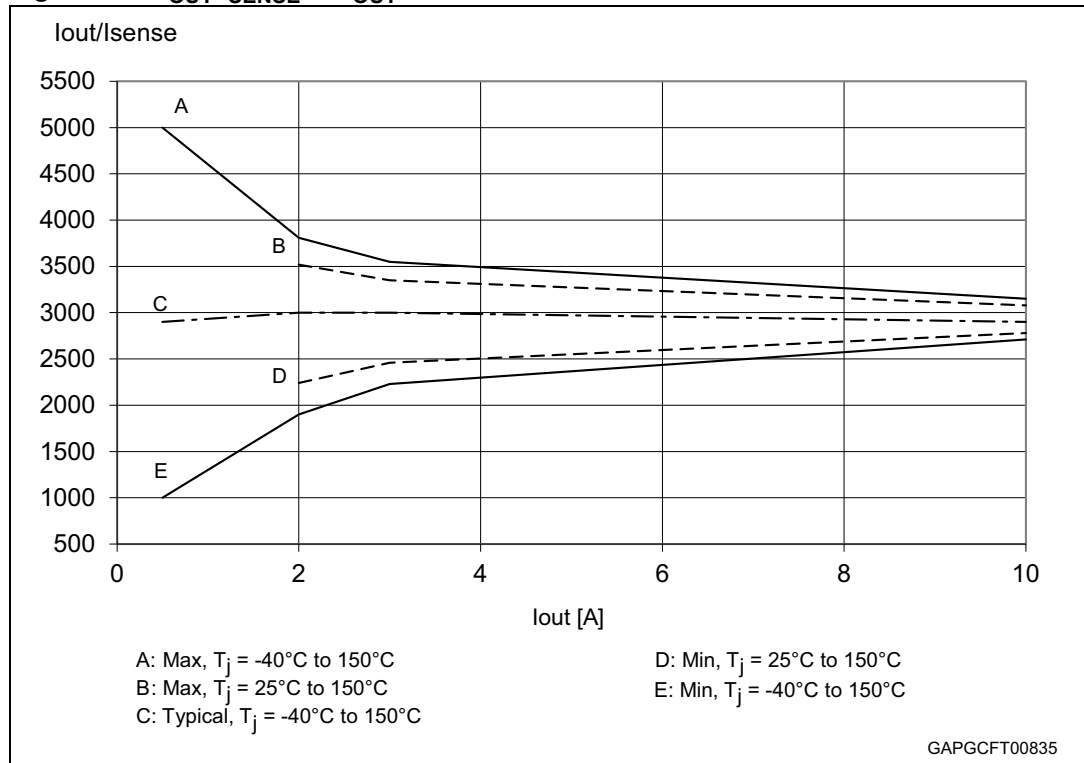
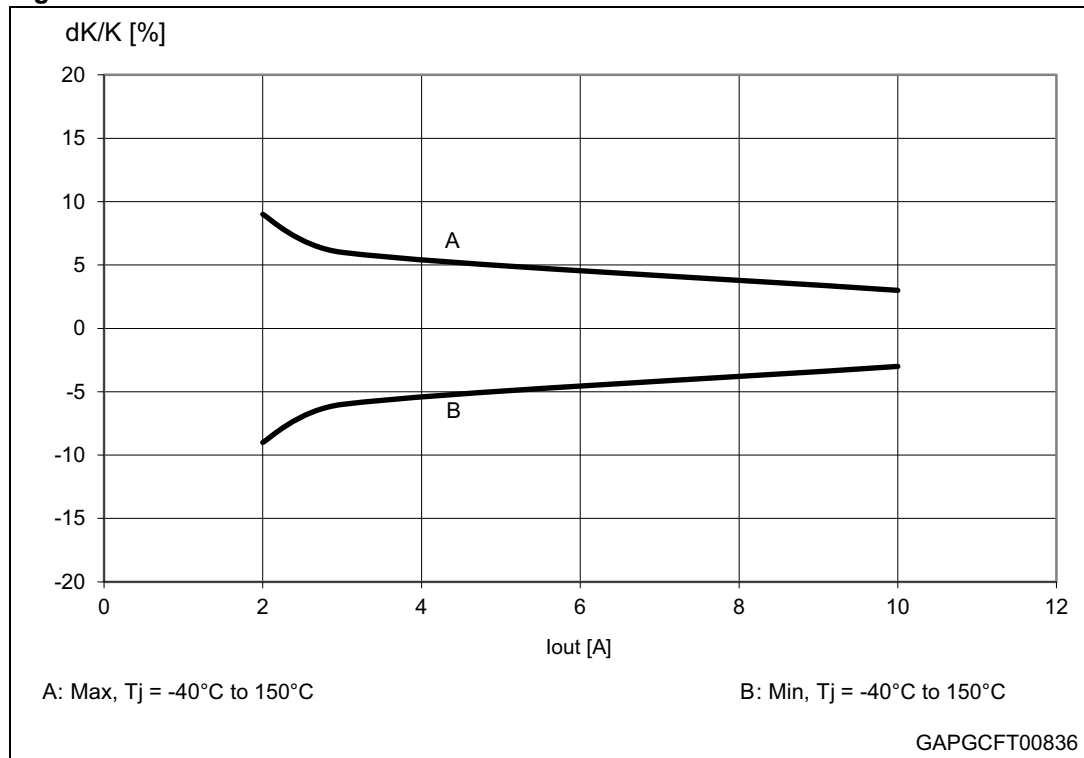

Figure 10. Maximum current sense ratio drift vs load current



1. Parameter guaranteed by design; it is not tested.

Table 11. Truth table

Conditions	Input	Output	Sense ($V_{CSD} = 0\text{ V}$) ⁽¹⁾
Normal operation	L	L	0
	H	H	Nominal
Overtemperature	L	L	0
	H	L	V_{SENSEH}
Undervoltage	L	L	0
	H	L	0
Overload	H	X (no power limitation)	Nominal
	H	Cycling (power limitation)	V_{SENSEH}
Short-circuit to GND (Power limitation)	L	L	0
	H	L	V_{SENSEH}
short-circuit to V_{CC} (external pull up disconnected)	L	H	V_{SENSEH}
	H	H	< Nominal
Negative output voltage clamp	L	L	0

1. If the V_{CSD} is high, the SENSE output is at a high impedance, its potential depends on leakage currents and external circuit.

Table 12. Electrical transient requirements (part 1)

ISO 7637-2: 2004(E) Test pulse	Test levels ⁽¹⁾		Number of pulses or test times	Burst cycle/pulse repetition time		Delays and impedance
	III	IV				
1	-75 V	-100 V	5000 pulses	0.5 s	5 s	2 ms, 10 Ω
2a	+37 V	+50 V	5000 pulses	0.2 s	5 s	50 μs, 2 Ω
3a	-100 V	-150 V	1 h	90 ms	100 ms	0.1 μs, 50 Ω
3b	+75 V	+100 V	1 h	90 ms	100 ms	0.1 μs, 50 Ω
4	-6 V	-7 V	1 pulse			100 ms, 0.01 Ω
5b ⁽²⁾	+65 V	+87 V	1 pulse			400 ms, 2 Ω

1. The above test levels must be considered referred to $V_{CC} = 13.5V$ except for pulse 5b
2. Valid in case of external load dump clamp: 40V maximum referred to ground.

Table 13. Electrical transient requirements (part 2)

ISO 7637-2: 2004(E) Test pulse	Test level results ⁽¹⁾	
	III	IV
1	C	C
2a	C	C
3a	C	C
3b	C	C
4	C	C
5b ⁽²⁾⁽³⁾	C	C

1. The above test levels must be considered referred to $V_{CC} = 13.5 V$ except for pulse 5b
2. Valid in case of external load dump clamp: 40 V maximum referred to ground.
3. Suppressed load dump (pulse 5b) is withstood with a minimum load connected as specified in [Table 3: Absolute maximum ratings](#).

Table 14. Electrical transient requirements (part 3)

Class	Contents
C	All functions of the device are performed as designed after exposure to disturbance.
E	One or more functions of the device are not performed as designed after exposure to disturbance and cannot be returned to proper operation without replacing the device.

2.4 Waveforms

Figure 11. Normal operation

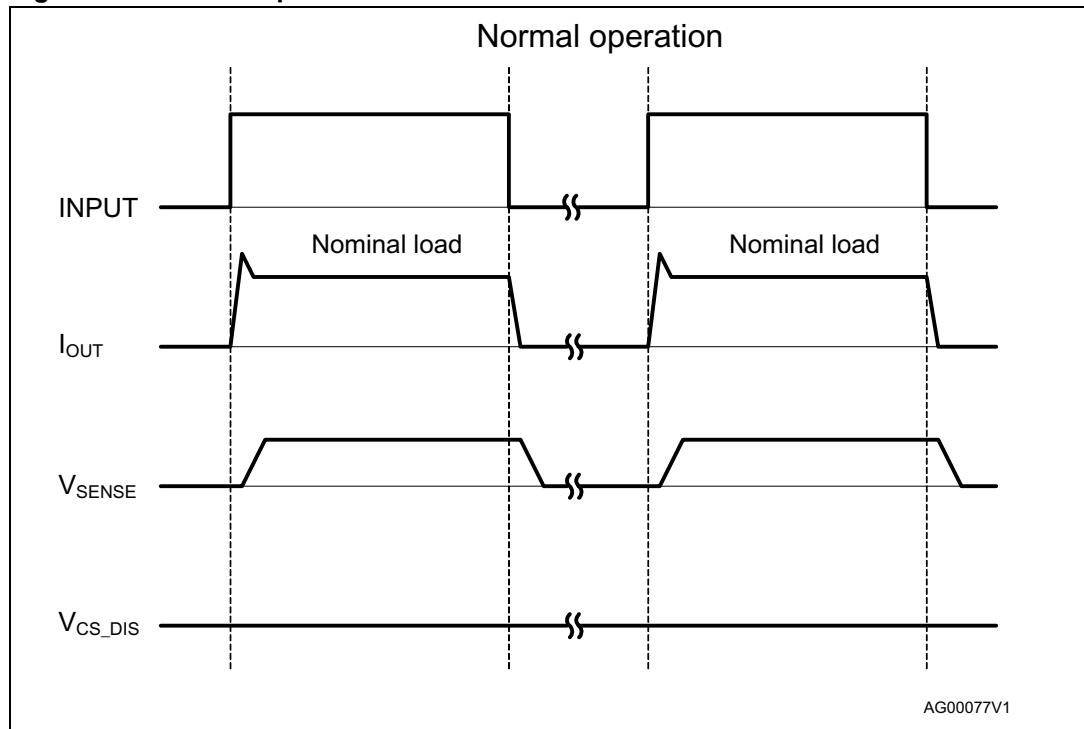

Figure 12. Overload or short to GND

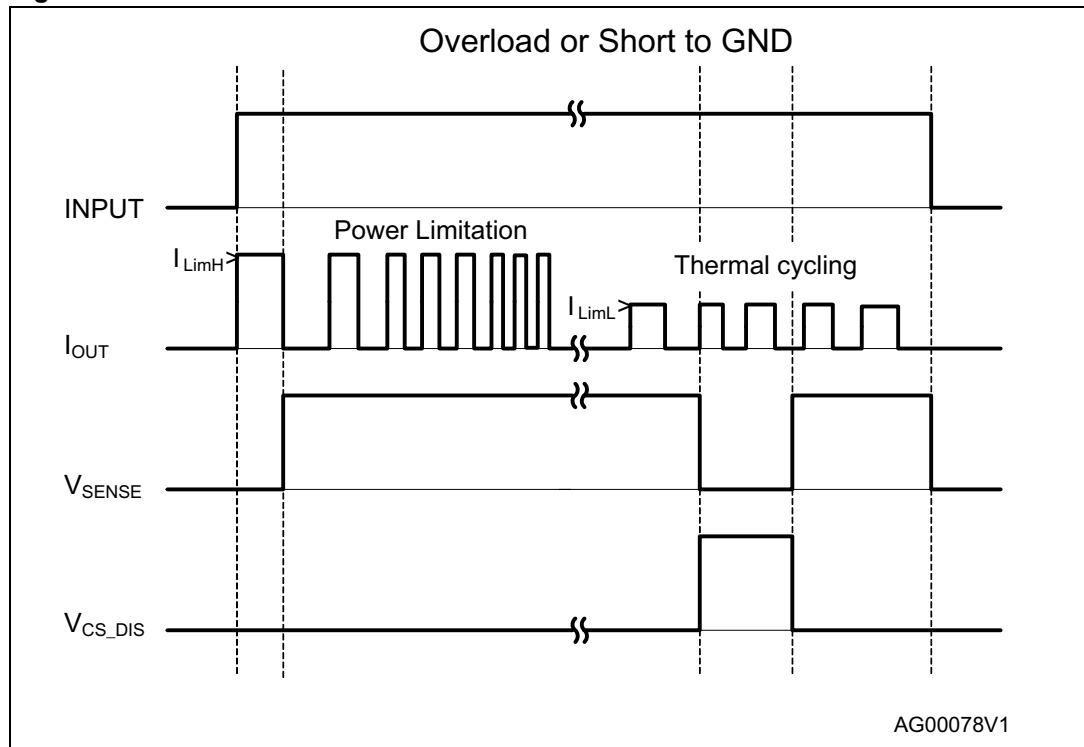

Figure 13. Intermittent overload

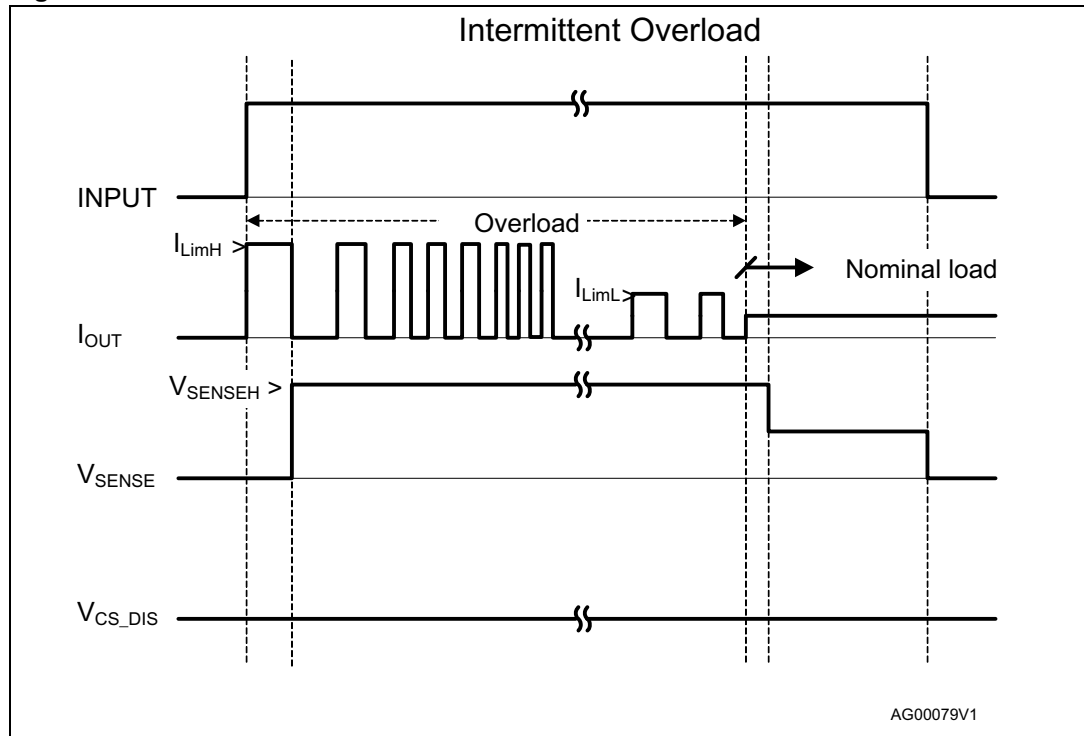

Figure 14. Short to V_{CC}

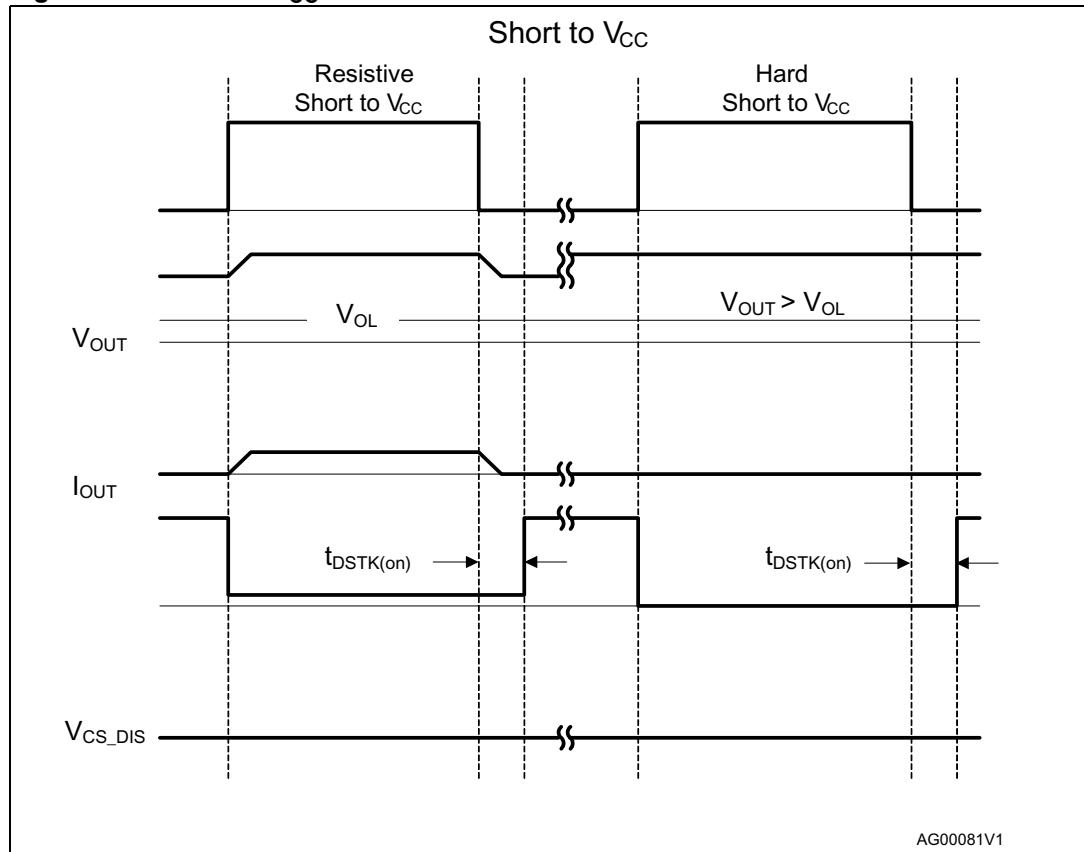
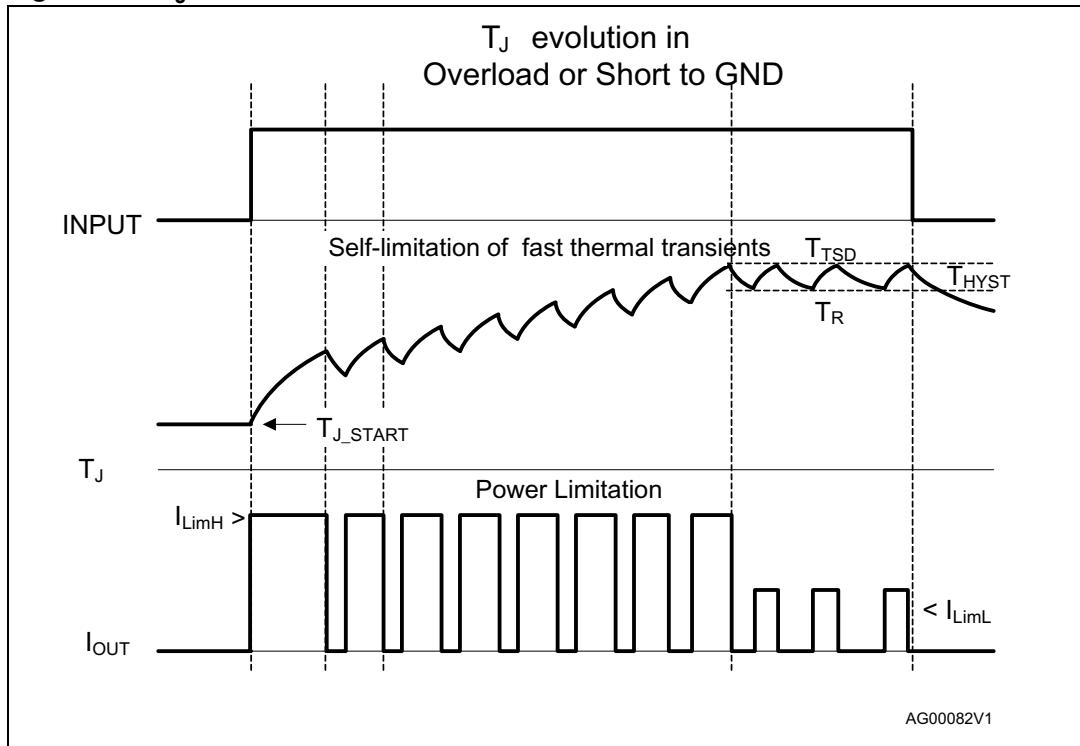

Figure 15. T_J evolution in overload or short to GND



2.5 Electrical characteristics curves

Figure 16. Off-state output current

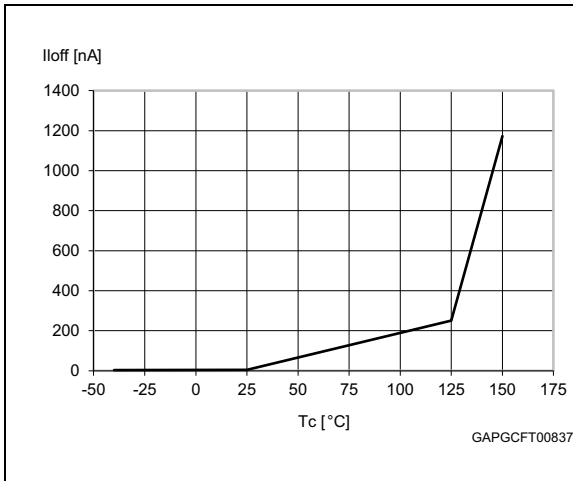

Figure 17. High-level input current

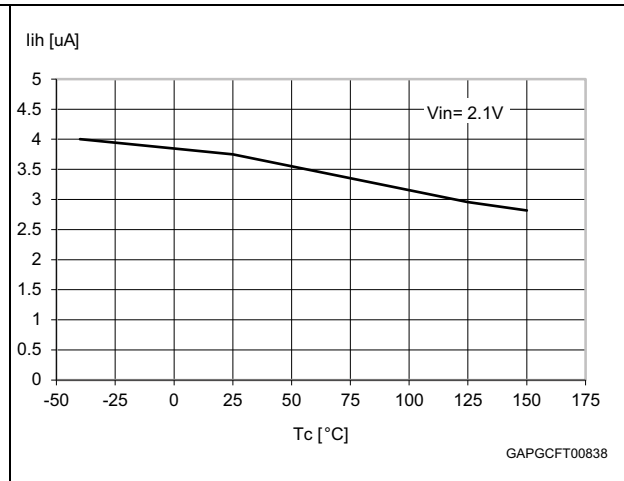

Figure 18. Input clamp voltage

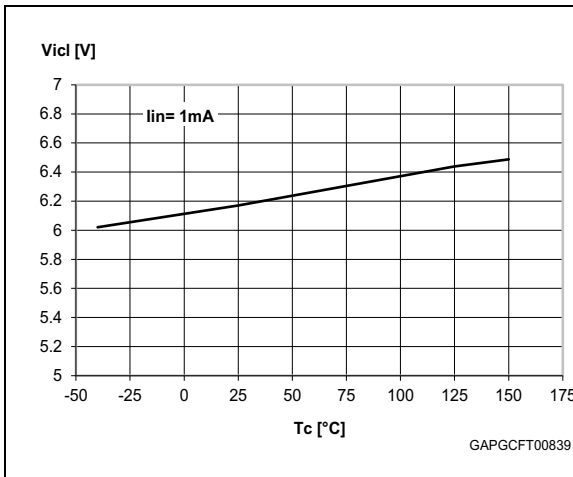

Figure 19. High-level input voltage

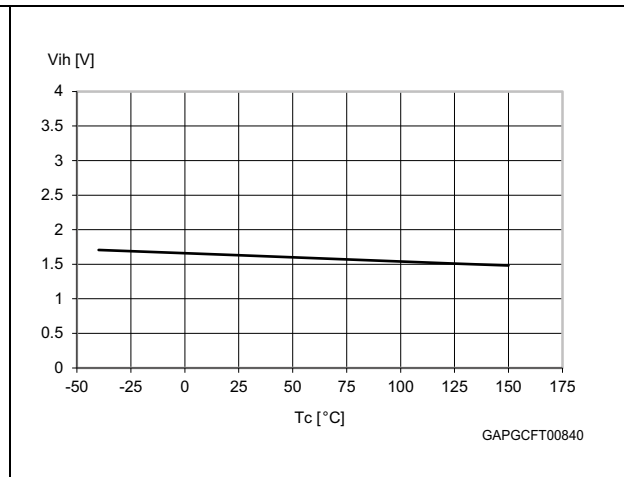

Figure 20. Low-level input voltage

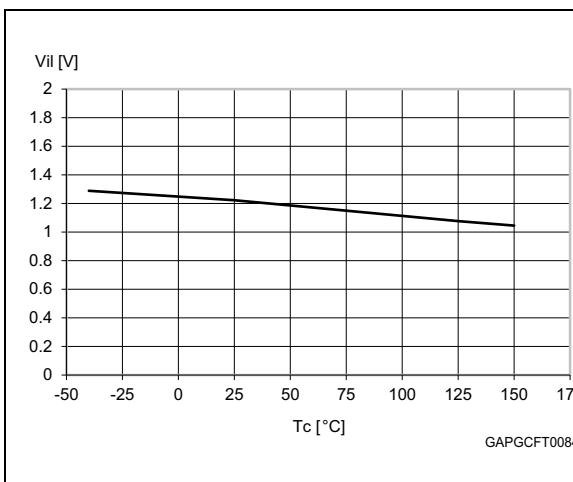

Figure 21. Input hysteresis voltage

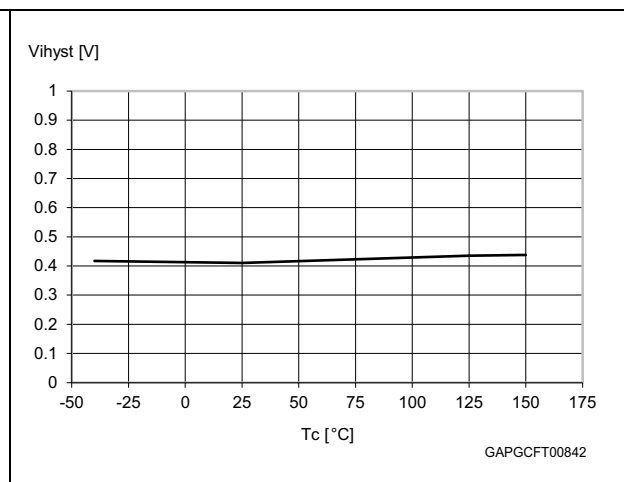

Figure 22. On-state resistance vs T_{case}

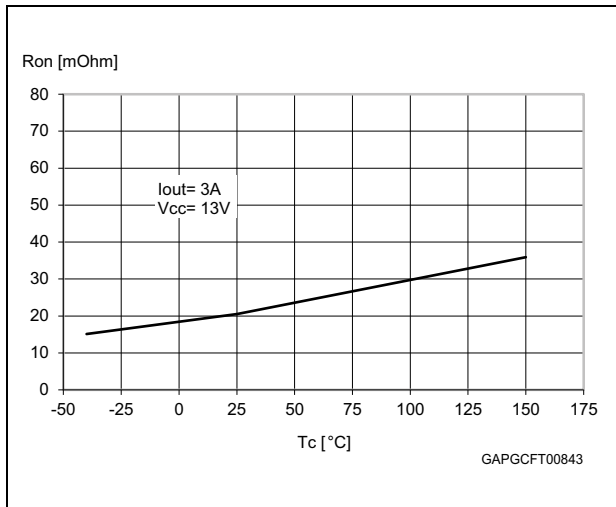

Figure 23. On-state resistance vs V_{CC}

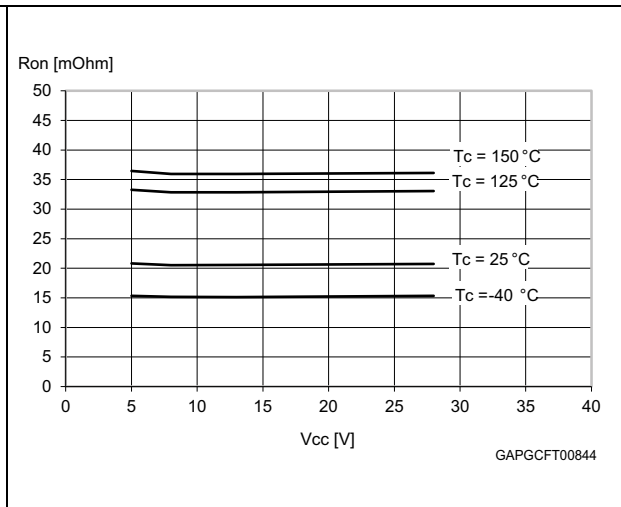

Figure 24. Undervoltage shutdown

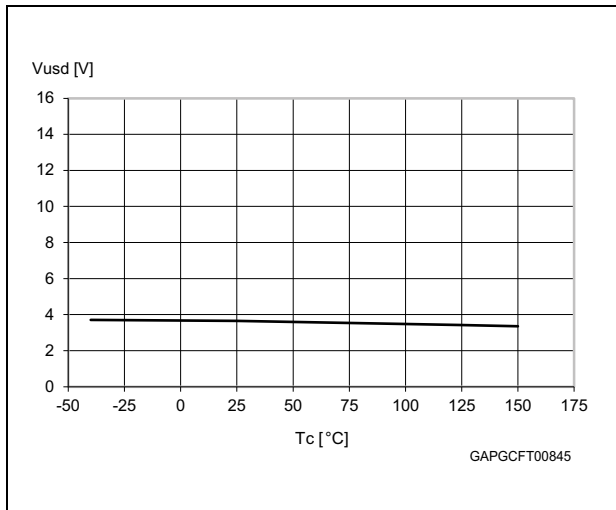

Figure 25. I_{LIMH} vs T_{case}

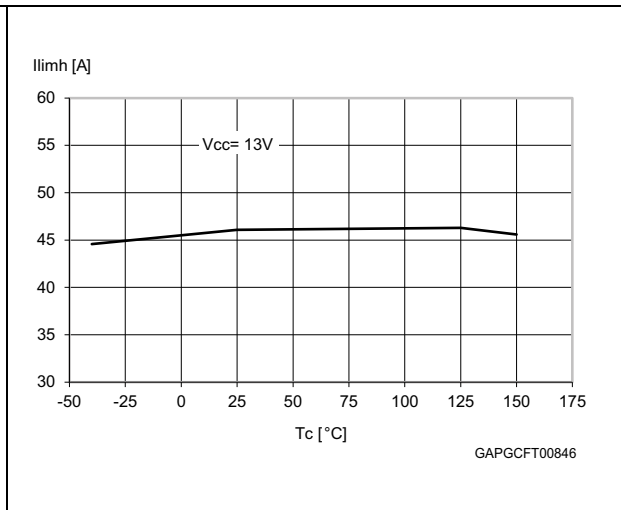

Figure 26. Turn-on voltage slope

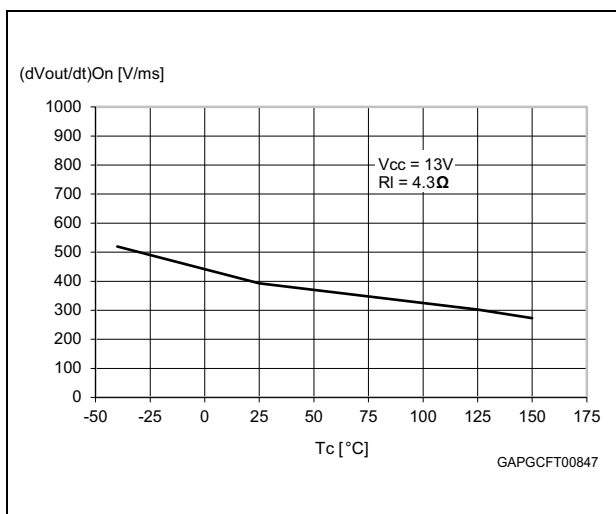

Figure 27. Turn-off voltage slope

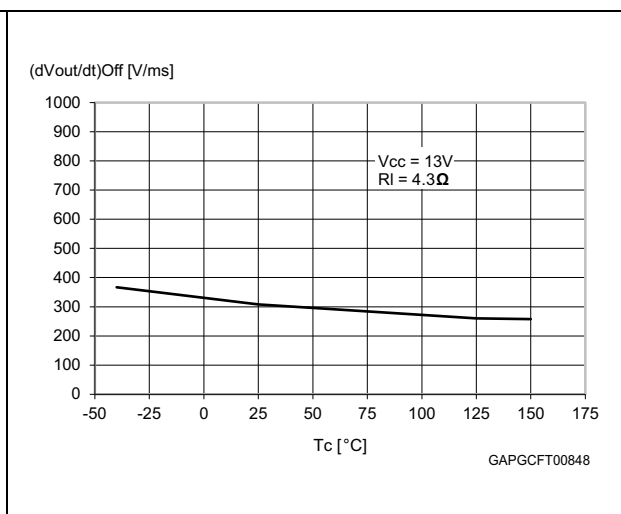

Figure 28. CS_DIS clamp voltage

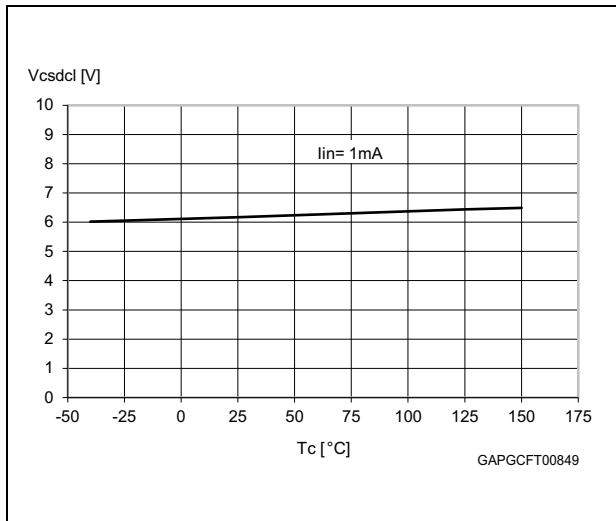

Figure 29. Low-level CS_DIS voltage

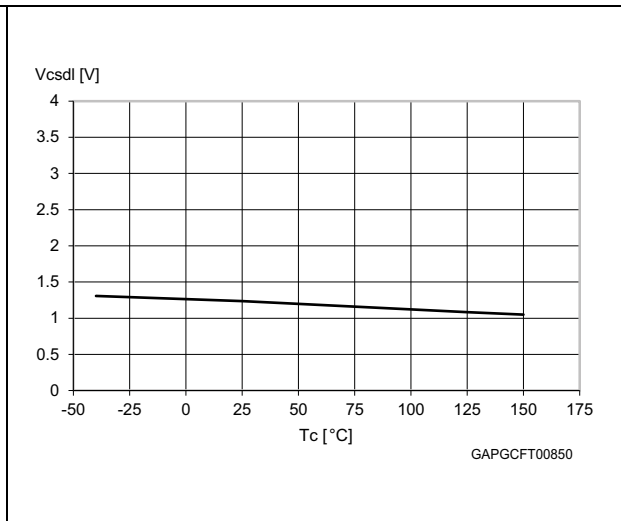
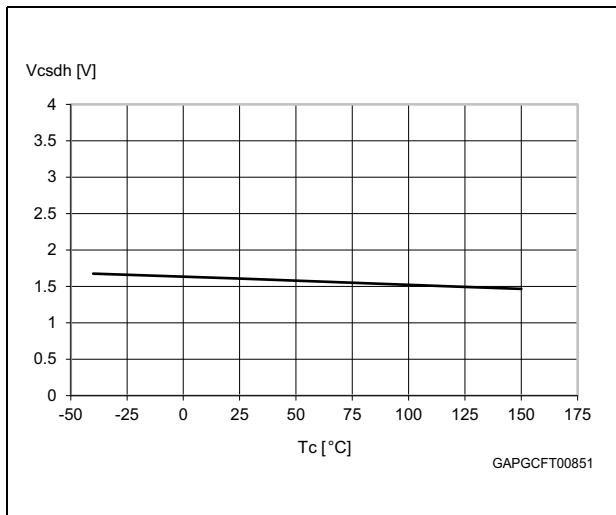

Figure 30. High-level CS_DIS voltage



Equation 1

$$-V_{CCpeak} / I_{latchup} \leq R_{prot} \leq (V_{OH\mu C} - V_{IH}) / I_{IHmax}$$

Calculation example:

For $V_{CCpeak} = -1.5 \text{ V}$; $I_{latchup} \geq 20 \text{ mA}$; $V_{OH\mu C} \geq 4.5 \text{ V}$

$$75 \Omega \leq R_{prot} \leq 240 \text{ k}\Omega.$$

Recommended values: $R_{prot} = 10 \text{ k}\Omega$, $C_{EXT} = 10 \text{ nF}$

3.3 Current sense and diagnostic

The current sense pin performs a double function (see [Figure 32: Current sense and diagnostic](#)):

- **Current mirror of the load current in normal operation**, delivering a current proportional to the load one according to a known ratio K_x .
The current I_{SENSE} can be easily converted to a voltage V_{SENSE} by means of an external resistor R_{SENSE} . Linearity between I_{OUT} and V_{SENSE} is ensured up to 5 V minimum (see parameter V_{SENSE} in [Table 7: Current sense \(8 V < \$V_{CC}\$ < 18 V\)](#)). The current sense accuracy depends on the output current (refer to current sense electrical characteristics [Table 7: Current sense \(8 V < \$V_{CC}\$ < 18 V\)](#)).
- **Diagnostic flag in fault conditions**, delivering a fixed voltage V_{SENSEH} up to a maximum current I_{SENSEH} in case of the following fault conditions (refer to [Table 11: Truth table](#)):
 - Power limitation activation
 - Over temperature
 - Short to V_{CC} in off-state
 - Open-load in off-state with additional external components.

A logic level high on CS_DIS pin sets at the same time all the current sense pins of the device in a high-impedance state, thus disabling the current monitoring and diagnostic detection. This feature allows multiplexing of the microcontroller analog inputs by sharing of sense resistance and ADC line among different devices.

Figure 32. Current sense and diagnostic

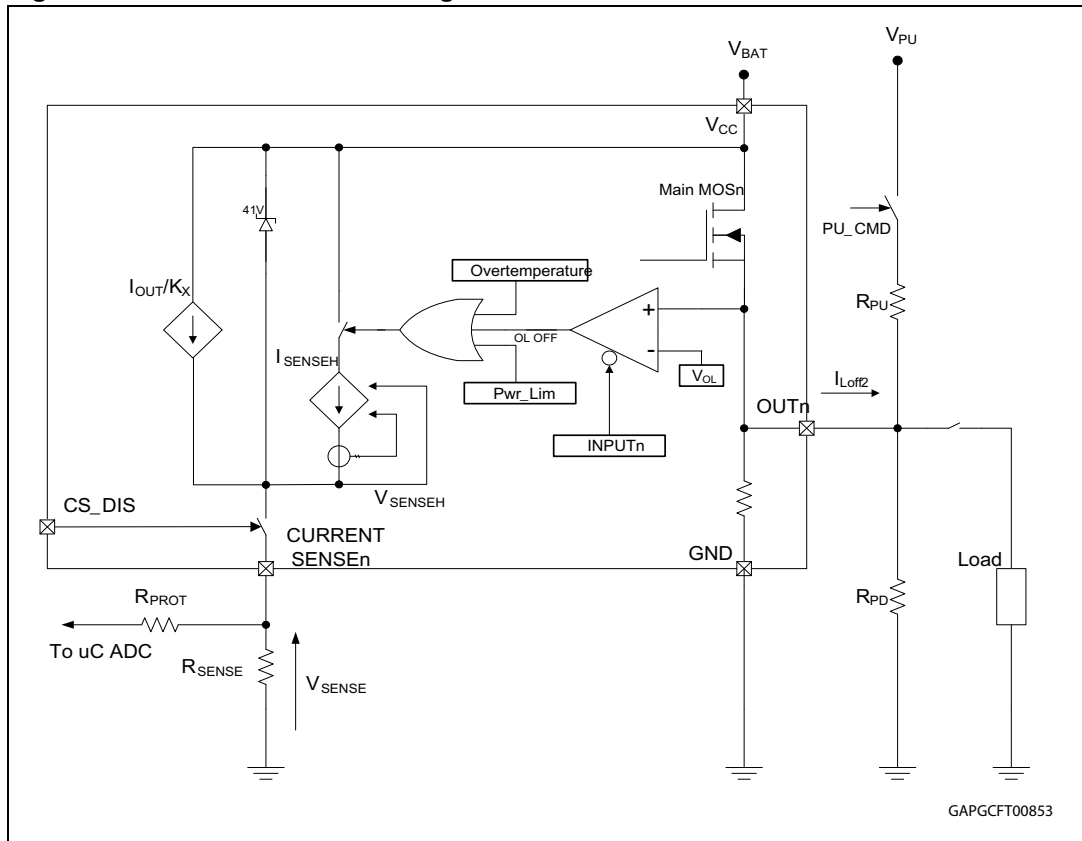

3.3.1 Short to V_{CC} and off-state open-load detection

Short to V_{CC}

A short-circuit between V_{CC} and output is indicated by the relevant current sense pin set to V_{SENSEH} during the device OFF-state. Small or no current is delivered by the current sense during the ON-state depending on the nature of the short-circuit.

Off-state open-load with external circuitry

Detection of an open load in off mode requires an external pull-up resistor R_{PU} connecting the output to a positive supply voltage V_{PU} .

It is preferable V_{PU} to be switched off during the module standby mode in order to avoid the overall standby current consumption to increase in normal conditions, i.e. when load is connected.

An external pull-down resistor R_{PD} connected between output and GND is mandatory to avoid misdetection in case of floating outputs in off-state (see [Figure 32: Current sense and diagnostic](#)).

R_{PD} must be selected in order to ensure $V_{OUT} < V_{OLmin}$ unless pulled-up by the external circuitry:

Equation 2

$$V_{OUT}|_{Pull-up_OFF} = R_{PD} \cdot I_{L(off2)f} < V_{OLmin} = 2V$$

$R_{PD} \leq 22 \text{ k}\Omega$ is recommended.

For proper open load detection in off-state, the external pull-up resistor must be selected according to the following formula:

Equation 3

$$V_{OUT}|_{Pull-up_ON} = \frac{(R_{PD} \cdot V_{PU}) - (R_{PU} \cdot R_{PD} \cdot I_{L(off2)r})}{(R_{PU} + R_{PD})} > V_{OLmax} = 4V$$

For the values of V_{OLmin} , V_{OLmax} , $I_{L(off2)r}$ and $I_{L(off2)f}$ (see [Table 8: Open-load detection \(8 V < V_{CC} < 18 V\)](#)).

3.4 Maximum demagnetization energy ($V_{CC} = 13.5\text{ V}$)

Figure 33. Maximum turn off current versus inductance

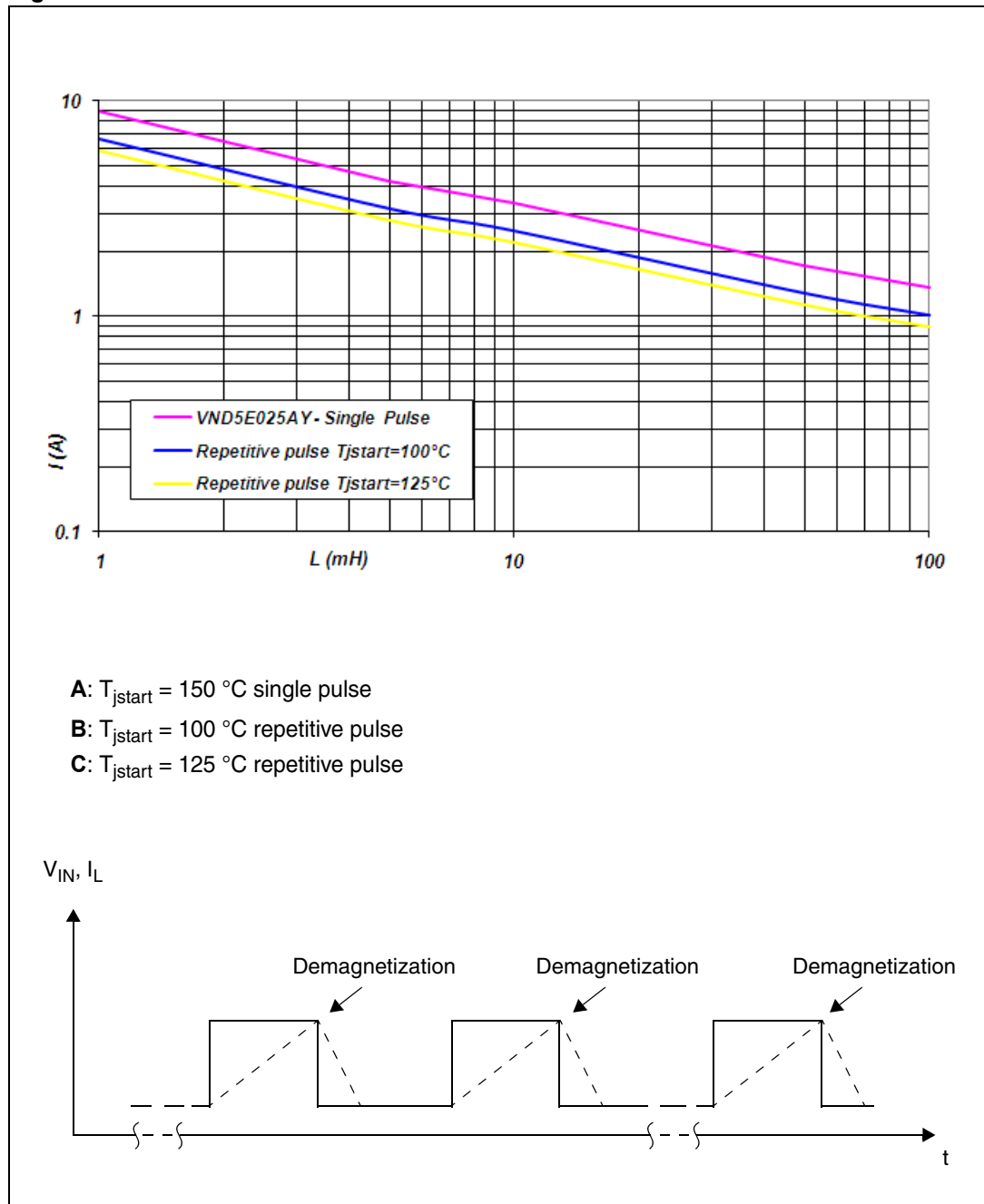

1. Values are generated with $R_L = 0\ \Omega$.
In case of repetitive pulses, T_{jstart} (at the beginning of each demagnetization) of every pulse must not exceed the temperature specified above for curves A and B.

4 Package and PCB thermal data

4.1 PowerSSO-36 thermal data

Figure 34. PowerSSO-36 PC board

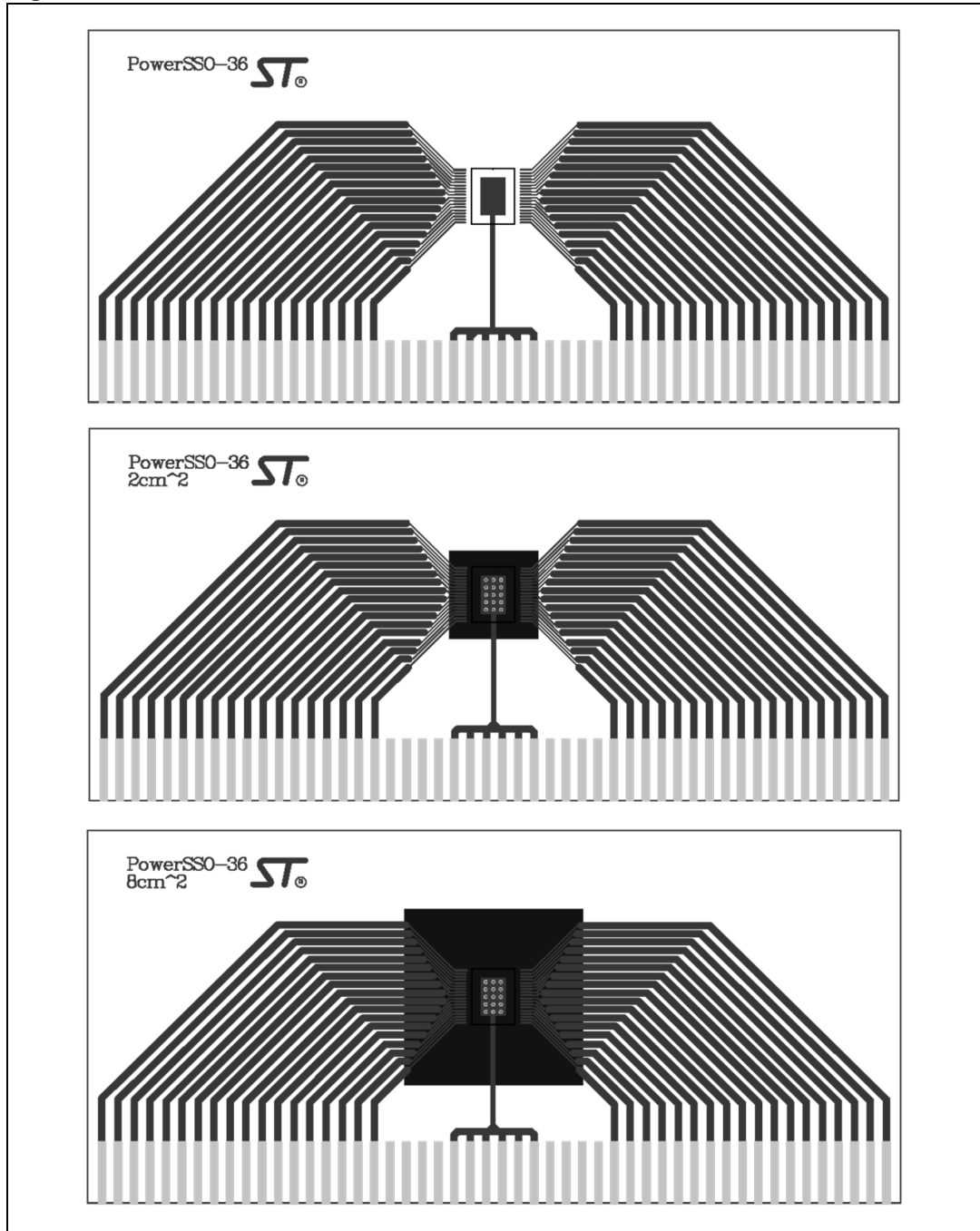

1. Layout condition of R_{th} and Z_{th} measurements (Board finish thickness 1.6 mm +/- 10%; Board double layer; Board dimension 129 mm x 60 mm; Board Material FR4; Cu thickness 0.070 mm; Thermal vias separation 1.2 mm; Thermal via diameter 0.3 mm +/- 0.08 mm; Cu thickness on vias 0.025 mm; Footprint dimension 4.1 mm x 6.5 mm).

Figure 35. $R_{thj-amb}$ vs PCB copper area in open box free air condition (one channel on)

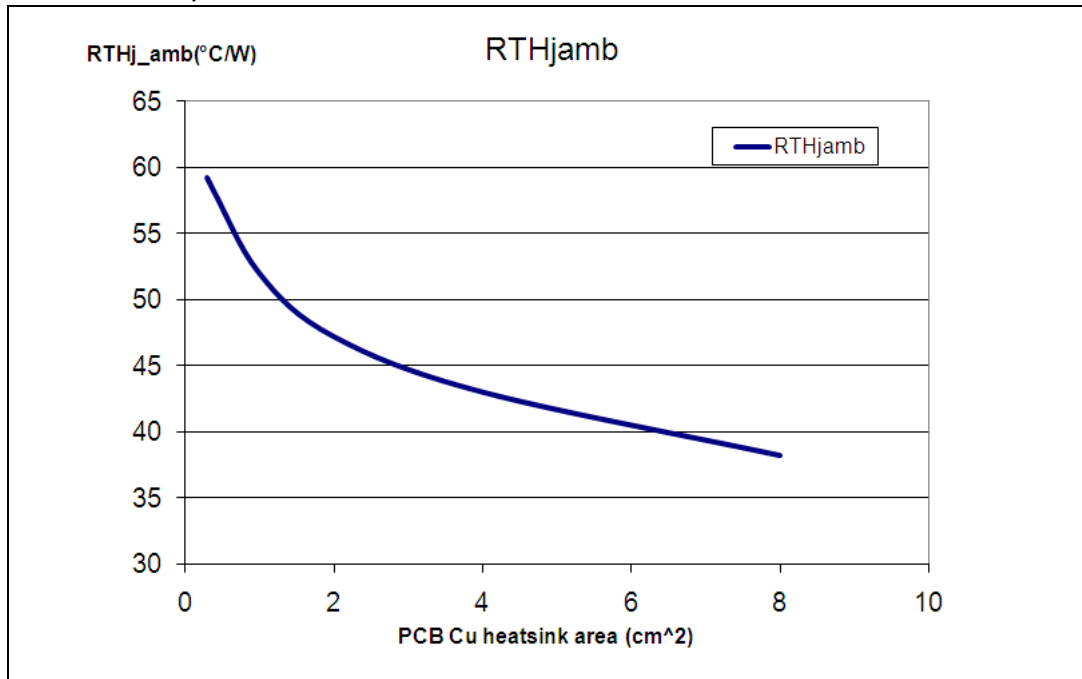
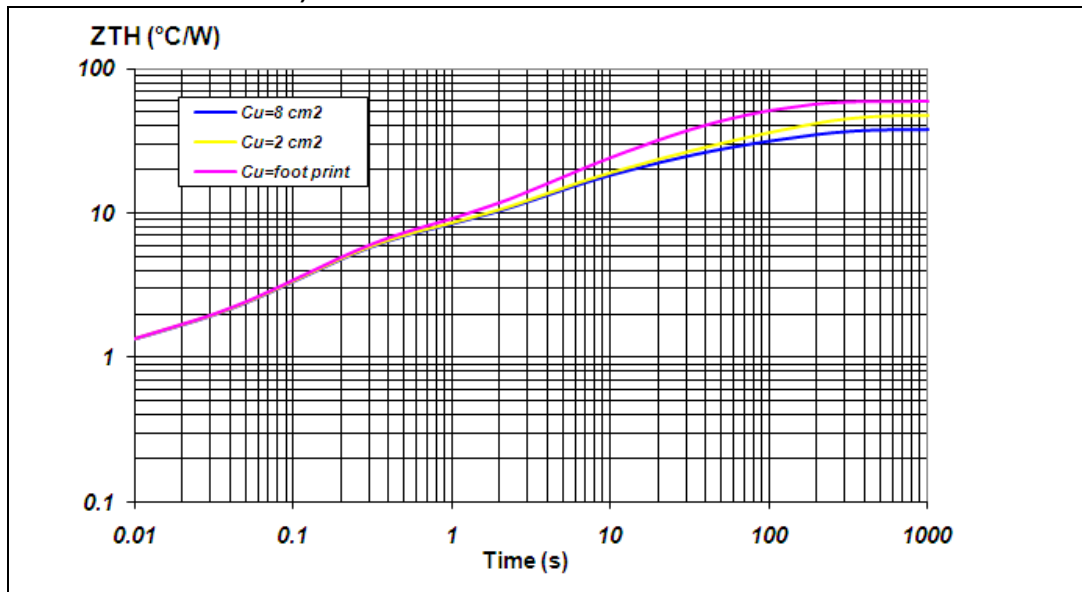

Figure 36. PowerSSO-36 thermal impedance junction ambient single pulse (one channel on)



Equation 4: pulse calculation formula

$$Z_{TH\delta} = R_{TH} \cdot \delta + Z_{THtp}(1 - \delta)$$

where $\delta = t_p/T$

Figure 37. Thermal fitting model of a double-channel HSD in PowerSSO-36

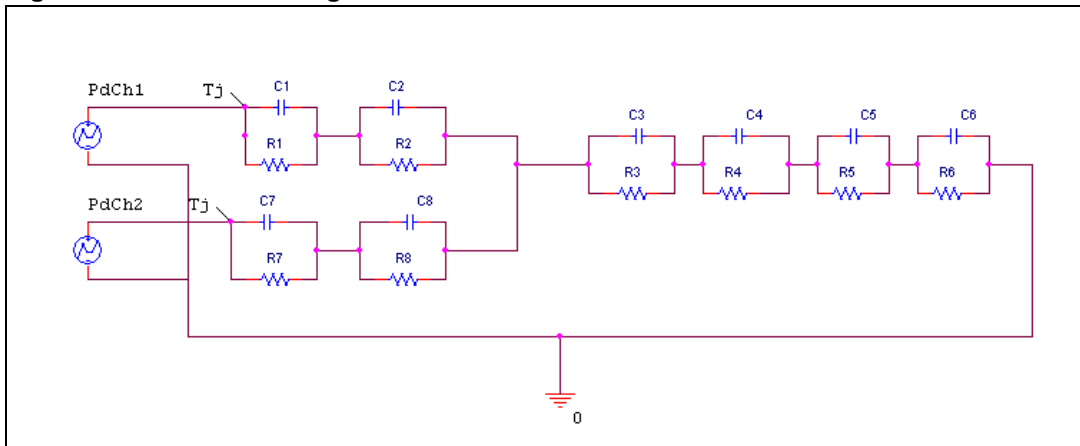

1. The fitting model is a simplified thermal tool and is valid for transient evolutions where the embedded protections (power limitation or thermal cycling during thermal shutdown) are not triggered.

Table 15. Thermal parameters

Area/island (cm ²)	Footprint	2	8
R1 = R7 (°C/W)	0.3		
R2 = R8 (°C/W)	0.9		
R3 (°C/W)	5		
R4 (°C/W)	8		
R5 (°C/W)	18	10	10
R6 (°C/W)	27	23	14
C1 = C7 (W.s/°C)	0.001		
C2 = C8 (W.s/°C)	0.005		
C3 (W.s/°C)	0.04		
C4 (W.s/°C)	0.5		
C5 (W.s/°C)	1	2	2
C6 (W.s/°C)	3	6	9

5 Package information

5.1 ECOPACK®

In order to meet environmental requirements, ST offers these devices in different grades of ECOPACK® packages, depending on their level of environmental compliance. ECOPACK® specifications, grade definitions and product status are available at: www.st.com.

ECOPACK® is an ST trademark.

5.2 PowerSSO-36 mechanical data

Figure 38. PowerSSO-36 package dimensions

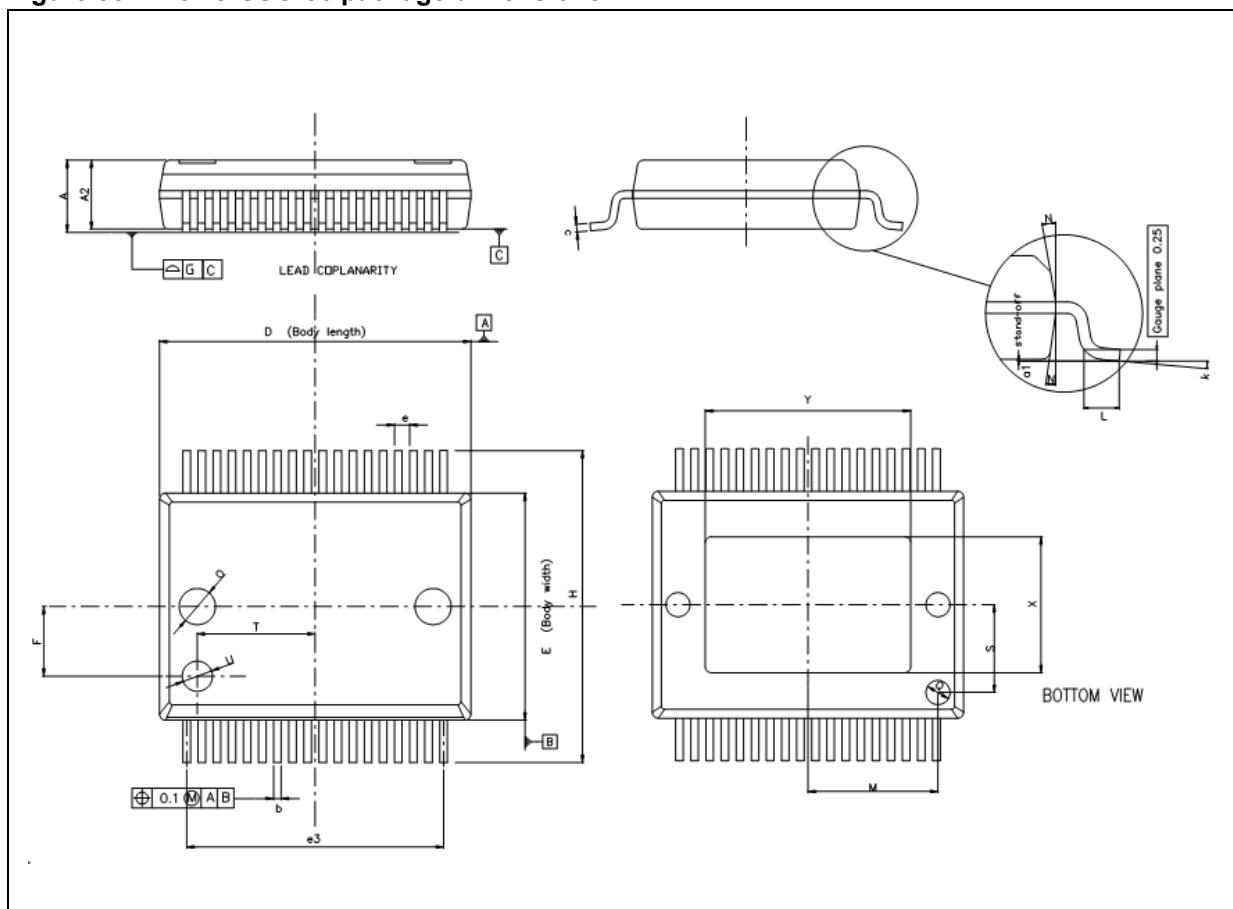

Table 16. PowerSSO-36 mechanical data

Symbol	millimeters		
	Min	Typ	Max
A	2.15	-	2.45
A2	2.15	-	2.35
a1	0	-	0.1
b	0.18	-	0.36
c	0.23	-	0.32
D	10.10	-	10.50
E	7.4	-	7.6
e	-	0.5	-
e3	-	8.5	-
F	-	2.3	-
G	-	-	0.1
H	10.1	-	10.5
h	-	-	0.4
k	0°	-	8°
L	0.55	-	0.85
M	-	4.3	-
N	-	-	10°
O	-	1.2	-
Q	-	0.8	-
S	-	2.9	-
T	-	3.65	-
U	-	1.0	-
X ⁽¹⁾	4.3	-	5.2
Y ⁽¹⁾	6.9	-	7.5

1. Corresponding to internal variation C.

5.3 Packing information

Figure 39. PowerSSO-36 tube shipment (no suffix)

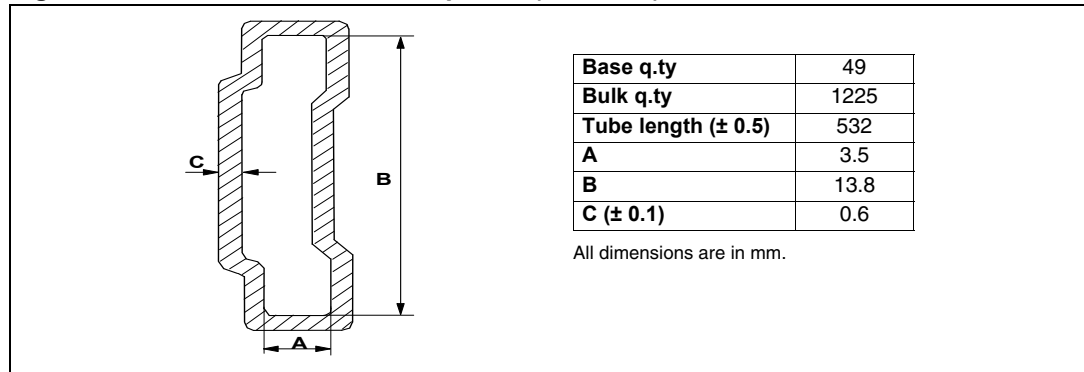
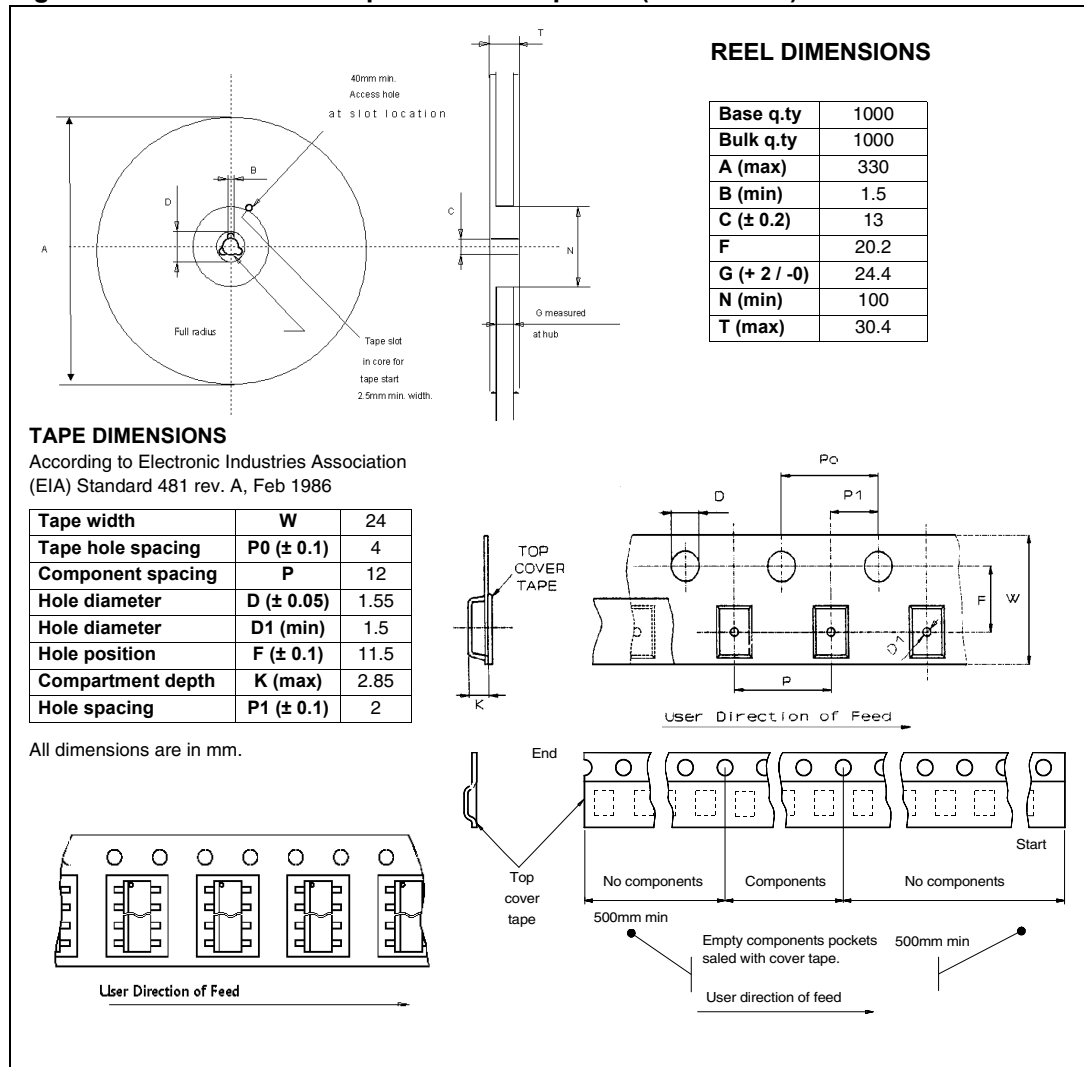

Figure 40. PowerSSO-36 tape and reel shipment (suffix "TR")



6 Device summary

Table 17. Device summary

Package	Order codes	
	Tube	Tape and reel
PowerSSO-36	VND5E025AY-E	VND5E025AYTR-E

7 Revision history

Table 18. Document revision history

Date	Revision	Changes
29-Jul-2010	1	Initial release.
05-Aug-2010	2	Updated following figures: – <i>Figure 35: $R_{thj-amb}$ vs PCB copper area in open box free air condition (one channel on)</i> – <i>Figure 36: PowerSSO-36 thermal impedance junction ambient single pulse (one channel on)</i> Updated <i>Table 15: Thermal parameters</i>
19-Jul-2012	3	Changed document status from “Preliminary data“ to “Production data“
19-Sep-2013	4	Updated Disclaimer

Please Read Carefully:

Information in this document is provided solely in connection with ST products. STMicroelectronics NV and its subsidiaries ("ST") reserve the right to make changes, corrections, modifications or improvements, to this document, and the products and services described herein at any time, without notice.

All ST products are sold pursuant to ST's terms and conditions of sale.

Purchasers are solely responsible for the choice, selection and use of the ST products and services described herein, and ST assumes no liability whatsoever relating to the choice, selection or use of the ST products and services described herein.

No license, express or implied, by estoppel or otherwise, to any intellectual property rights is granted under this document. If any part of this document refers to any third party products or services it shall not be deemed a license grant by ST for the use of such third party products or services, or any intellectual property contained therein or considered as a warranty covering the use in any manner whatsoever of such third party products or services or any intellectual property contained therein.

UNLESS OTHERWISE SET FORTH IN ST'S TERMS AND CONDITIONS OF SALE ST DISCLAIMS ANY EXPRESS OR IMPLIED WARRANTY WITH RESPECT TO THE USE AND/OR SALE OF ST PRODUCTS INCLUDING WITHOUT LIMITATION IMPLIED WARRANTIES OF MERCHANTABILITY, FITNESS FOR A PARTICULAR PURPOSE (AND THEIR EQUIVALENTS UNDER THE LAWS OF ANY JURISDICTION), OR INFRINGEMENT OF ANY PATENT, COPYRIGHT OR OTHER INTELLECTUAL PROPERTY RIGHT.

ST PRODUCTS ARE NOT DESIGNED OR AUTHORIZED FOR USE IN: (A) SAFETY CRITICAL APPLICATIONS SUCH AS LIFE SUPPORTING, ACTIVE IMPLANTED DEVICES OR SYSTEMS WITH PRODUCT FUNCTIONAL SAFETY REQUIREMENTS; (B) AERONAUTIC APPLICATIONS; (C) AUTOMOTIVE APPLICATIONS OR ENVIRONMENTS, AND/OR (D) AEROSPACE APPLICATIONS OR ENVIRONMENTS. WHERE ST PRODUCTS ARE NOT DESIGNED FOR SUCH USE, THE PURCHASER SHALL USE PRODUCTS AT PURCHASER'S SOLE RISK, EVEN IF ST HAS BEEN INFORMED IN WRITING OF SUCH USAGE, UNLESS A PRODUCT IS EXPRESSLY DESIGNATED BY ST AS BEING INTENDED FOR "AUTOMOTIVE, AUTOMOTIVE SAFETY OR MEDICAL" INDUSTRY DOMAINS ACCORDING TO ST PRODUCT DESIGN SPECIFICATIONS. PRODUCTS FORMALLY ESCC, QML OR JAN QUALIFIED ARE DEEMED SUITABLE FOR USE IN AEROSPACE BY THE CORRESPONDING GOVERNMENTAL AGENCY.

Resale of ST products with provisions different from the statements and/or technical features set forth in this document shall immediately void any warranty granted by ST for the ST product or service described herein and shall not create or extend in any manner whatsoever, any liability of ST.

ST and the ST logo are trademarks or registered trademarks of ST in various countries.

Information in this document supersedes and replaces all information previously supplied.

The ST logo is a registered trademark of STMicroelectronics. All other names are the property of their respective owners.

© 2013 STMicroelectronics - All rights reserved



STMicroelectronics group of companies

Australia - Belgium - Brazil - Canada - China - Czech Republic - Finland - France - Germany - Hong Kong - India - Israel - Italy - Japan - Malaysia - Malta - Morocco - Philippines - Singapore - Spain - Sweden - Switzerland - United Kingdom - United States of America

www.st.com

Looking for pricing, stock, or lifecycle information?

Click below to explore more details on WIN SOURCE:

-  [View VND5E025AY-E on WIN SOURCE](#)
-  [STMicroelectronics](#) Information

Optimize Your Supply Chain with WIN SOURCE Solutions

-  Global Sourcing Solution
-  Obsolete Management
-  Cost Control Management
-  Shortage Management
-  Alternative Solution
-  Excess Inventory Management