



**THE DATASHEET OF
ESD5V5U5ULCE6327HTSA1**



ESD5V5U5ULC

Ultra-low capacitance ESD / transient / surge protection array

TVS (transient voltage suppressor)

5.5 V, 0.45 pF, RoHS compliant

Feature list

- ESD/transient protection of high speed data lines exceeding:
 - IEC61000-4-2 (ESD): ± 25 kV (air/contact)
 - IEC61000-4-4 (EFT): ± 2.5 kV/ ± 50 A (5/50 ns)
 - IEC61000-4-5 (Surge): ± 6 A (8/20 μ s)
- Maximum working voltage: $V_{RWM} = 5.5$ V
- Extremely low capacitance: $C_L = 0.45$ pF I/O to GND (typical)
- Very low dynamic resistance: $R_{DYN} = 0.2 \Omega$ (typical) I/O to GND
- Very low reverse clamping voltage: $V_{CL} = 9$ V (typical) at $I_{PP} = 16$ A
- Protection of V_{BUS} with one line freely selectable



Potential applications

- Protection of all I/O and V_{BUS} lines in dual USB2.0 ports
- 10/100/1000 Ethernet
- DVI, HDMI, FireWire

Product validation

Qualified for industrial applications according to the relevant tests of JEDEC47/20/22

Device information

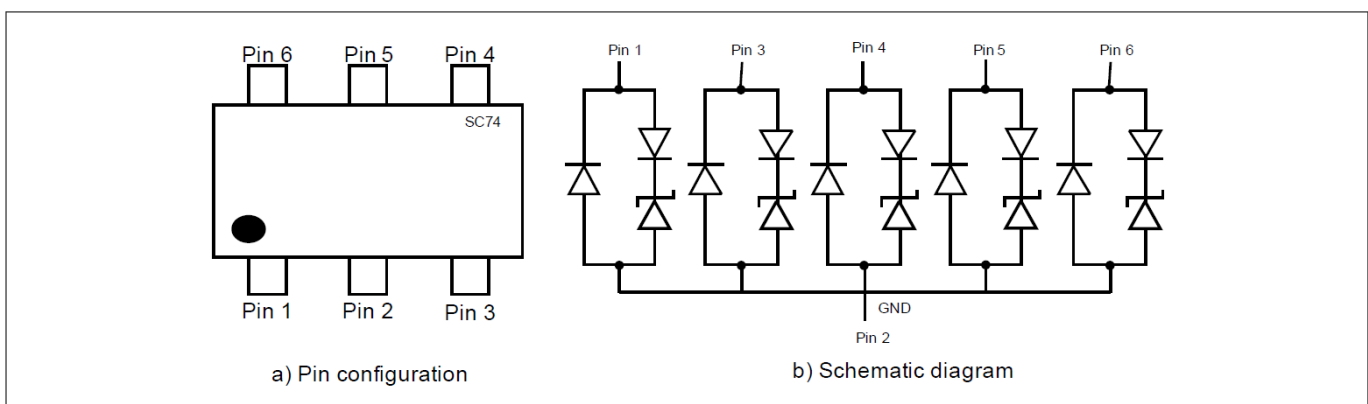

Figure 1 Pin configuration and schematic diagram

Table 1 Part information

Type	Package	Configuration	Marking code
ESD5V5U5ULC	PG-SC74-6-2	5 lines, uni-directional	20

Table of contents

	Feature list	1
	Potential applications	1
	Product validation	1
	Device information	1
	Table of contents	2
1	Maximum ratings	3
2	Electrical characteristics	4
3	Typical characteristic diagrams	6
4	Application information	10
5	Package information	11
5.1	PG-SC74-6-2 package	11
6	References	12
	Revision history	12
	Disclaimer	13

Maximum ratings

1 Maximum ratings

Note: $T_A = 25\text{ °C}$, unless otherwise specified.

Table 2 Maximum ratings

Parameter	Symbol	Values	Unit	Note or test condition
ESD contact discharge ¹⁾	V_{ESD}	± 25	kV	–
Peak pulse current ²⁾	I_{PP}	± 6	A	$t_p = 8/20\ \mu\text{s}$
Operating temperature range	T_{OP}	-40 to 125	°C	–
Storage temperature	T_{stg}	-65 to 150	°C	–

Attention: *Stresses above the maximum values listed here may cause permanent damage to the device. Exposure to absolute maximum rating conditions for extended periods may affect device reliability. Maximum ratings are absolute ratings. Exceeding only one of these values may cause irreversible damage to the component.*

¹ V_{ESD} according to IEC61000-4-2

² I_{PP} according to IEC61000-4-5

Electrical characteristics

2 Electrical characteristics

Note: $T_A = 25\text{ }^\circ\text{C}$, unless otherwise specified.

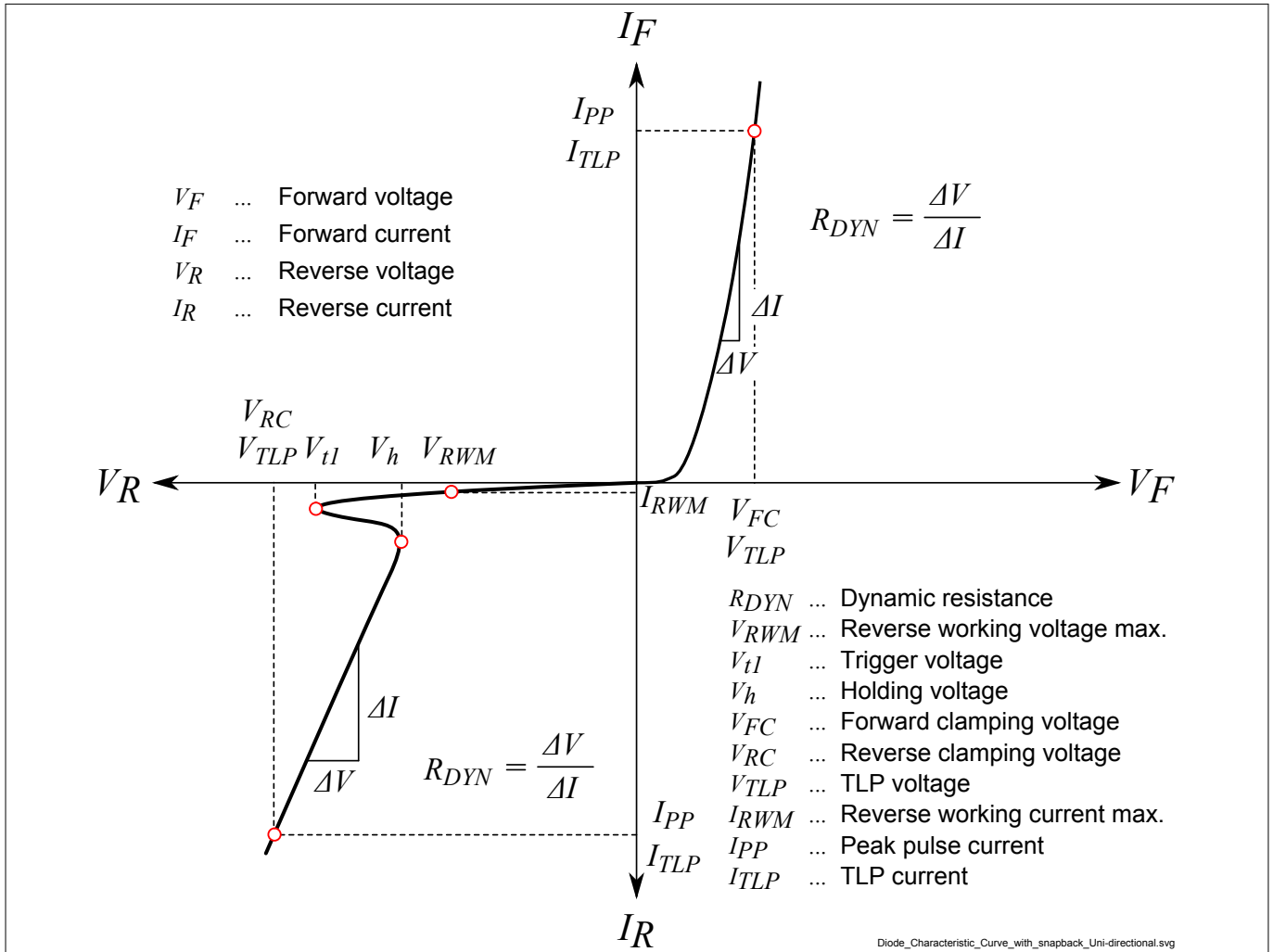

Figure 2 Definitions of electrical characteristics

Table 3 DC characteristics

Parameter	Symbol	Values			Unit	Note or test condition
		Min.	Typ.	Max.		
Reverse working voltage	V_{RWM}	-	-	5.5	V	I/O to GND
Reverse current	I_R	-	<1	100	nA	$V_R = 5.5\text{ V}$, I/O to GND

Electrical characteristics

Table 4 RF characteristics

Parameter	Symbol	Values			Unit	Note or test condition
		Min.	Typ.	Max.		
Line capacitance	C_L	-	0.45	1	pF	$V_R = 0\text{ V}, f = 1\text{ MHz}, \text{I/O to GND}$
		-	0.23	0.5		$V_R = 0\text{ V}, f = 1\text{ MHz}, \text{I/O to I/O}$
Line capacitance	C_L	-	0.25	-	pF	$V_R = 0\text{ V}, f = 825\text{ MHz}, \text{I/O to GND}$
		-	0.13	-		$V_R = 0\text{ V}, f = 825\text{ MHz}, \text{I/O to I/O}$
Capacitance variation between I/O and GND	$\Delta C_{i/o-GND}$	-	0.02	-	pF	$V_R = 0\text{ V}, f = 1\text{ MHz}, \text{I/O to GND}$
Capacitance variation between I/O	$\Delta C_{i/o-i/o}$	-	0.01	-	pF	$V_R = 0\text{ V}, f = 1\text{ MHz}, \text{I/O to I/O}$

Table 5 ESD and surge characteristics

Parameter	Symbol	Values			Unit	Note or test condition
		Min.	Typ.	Max.		
Reverse clamping voltage ¹⁾	V_{CL}	-	9	-	V	$I_{PP} = 1\text{ A}, t_p = 8/20\ \mu\text{s}, \text{I/O pin to GND}$
		-	12	-		$I_{PP} = 3\text{ A}, t_p = 8/20\ \mu\text{s}, \text{I/O pin to GND}$
Reverse clamping voltage ²⁾	V_{CL}	-	8.9	-	V	$I_{TLP} = 16\text{ A}, t_p = 100\text{ ns}, \text{I/O pin to GND}$
		-	11.5	-		$I_{TLP} = 30\text{ A}, t_p = 100\text{ ns}, \text{I/O pin to GND}$
Forward clamping voltage ¹⁾	V_{FC}	-	1.75	-	V	$I_{PP} = 1\text{ A}, t_p = 8/20\ \mu\text{s}, \text{GND pin to I/O}$
		-	2.5	-		$I_{PP} = 3\text{ A}, t_p = 8/20\ \mu\text{s}, \text{GND pin to I/O}$
Forward clamping voltage ²⁾	V_{FC}	-	5.4	-	V	$I_{TLP} = 16\text{ A}, t_p = 100\text{ ns}, \text{GND pin to I/O}$
		-	9.2	-		$I_{TLP} = 30\text{ A}, t_p = 100\text{ ns}, \text{GND pin to I/O}$
Dynamic resistance ²⁾	R_{DYN}	-	0.2	-	Ω	I/O to GND
Dynamic resistance ²⁾	R_{DYN}	-	0.3	-	Ω	GND to I/O

¹⁾ I_{PP} according to IEC61000-4-5

²⁾ Please refer to application note AN210, TLP parameters: $Z_0 = 50\ \Omega$, $t_p = 100\text{ ns}$, $t_r = 300\text{ ps}$, averaging window: $t_1 = 30\text{ ns}$ to $t_2 = 60\text{ ns}$, extraction of dynamic resistance using least squares fit of TLP characteristic between $I_{PP1} = 10\text{ A}$ and $I_{PP2} = 40\text{ A}$.

Typical characteristic diagrams

3 Typical characteristic diagrams

Note: $T_A = 25\text{ }^\circ\text{C}$, unless otherwise specified.

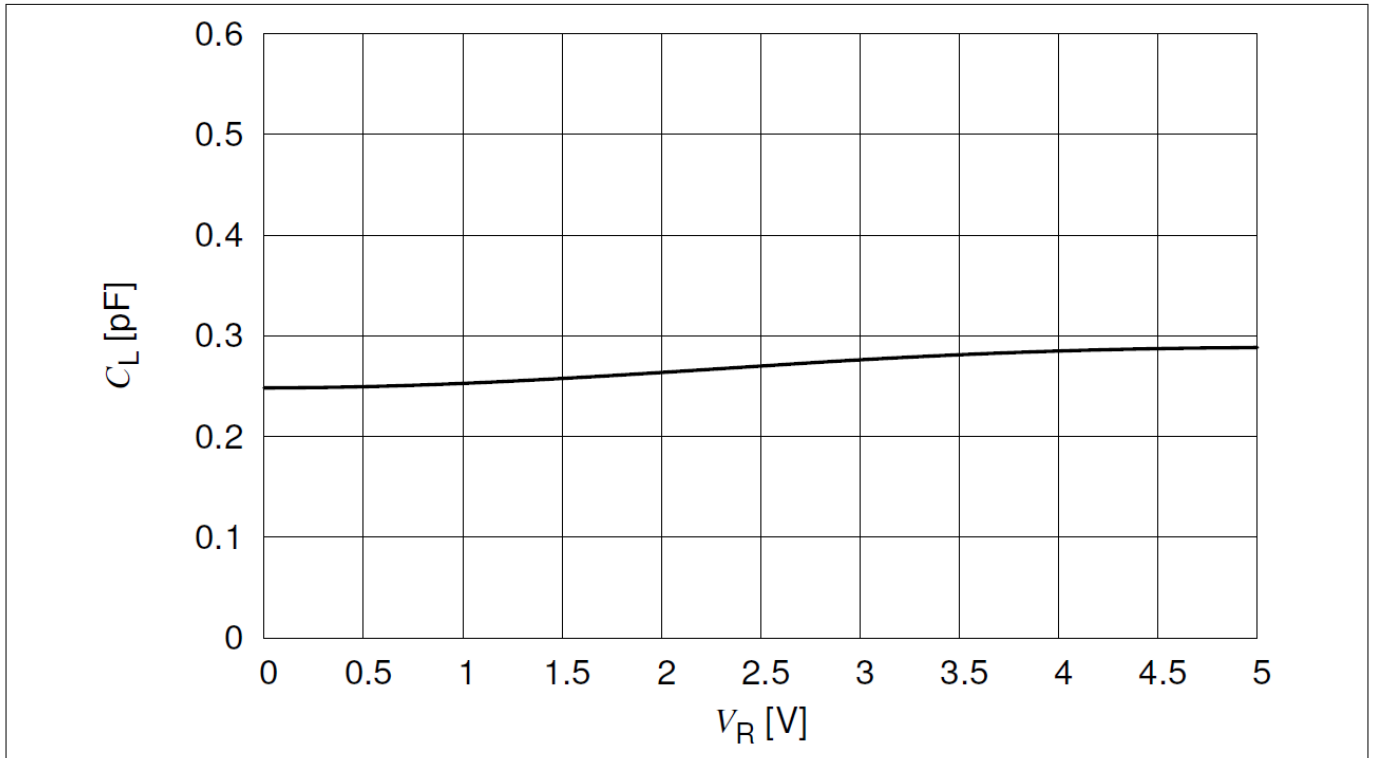

Figure 3 Line capacitance $C_L = f(V_R)$ at $f = 825\text{ MHz}$

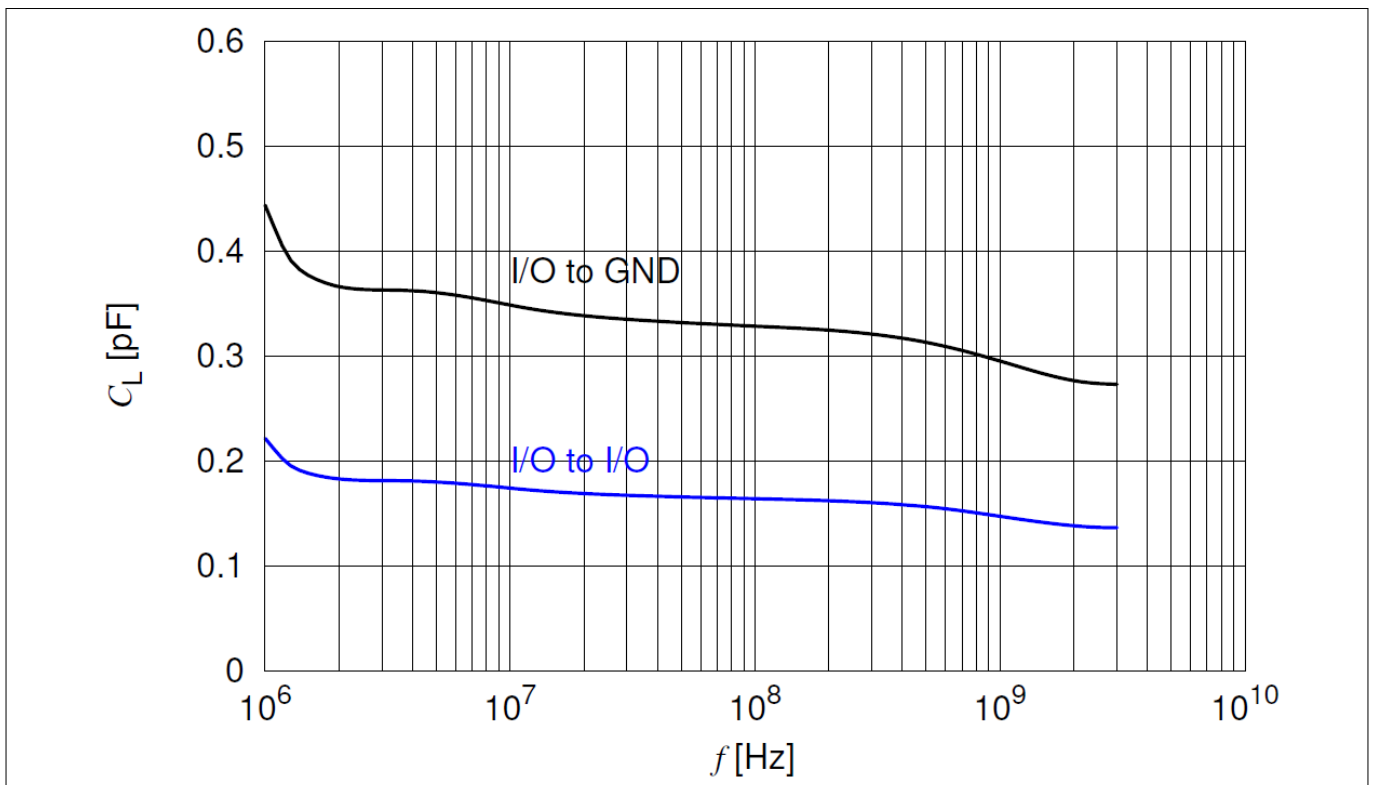

Figure 4 Line capacitance $C_L = f(f)$, $V_R = 0\text{ V}$

Typical characteristic diagrams

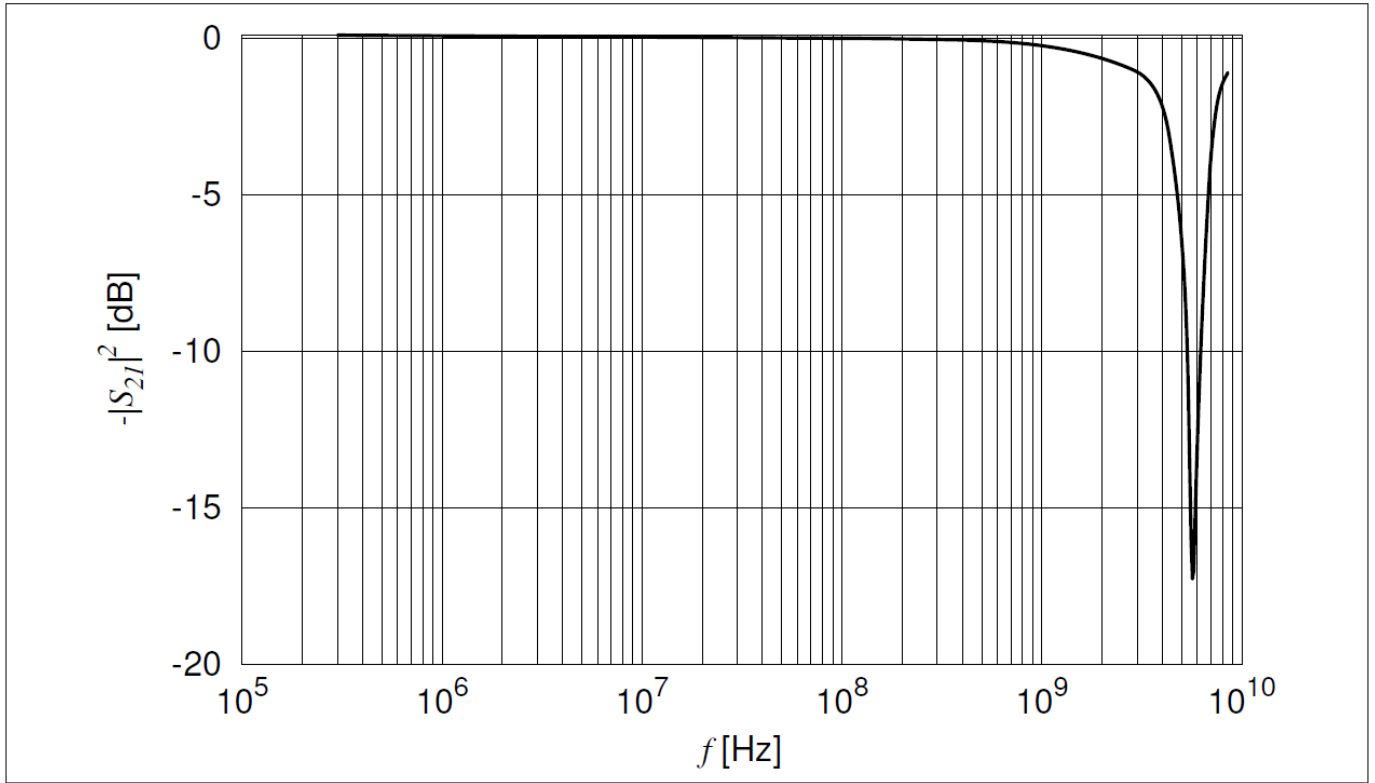

Figure 5 Insertion loss $I_L = f(f)$, $V_R = 0\text{ V}$

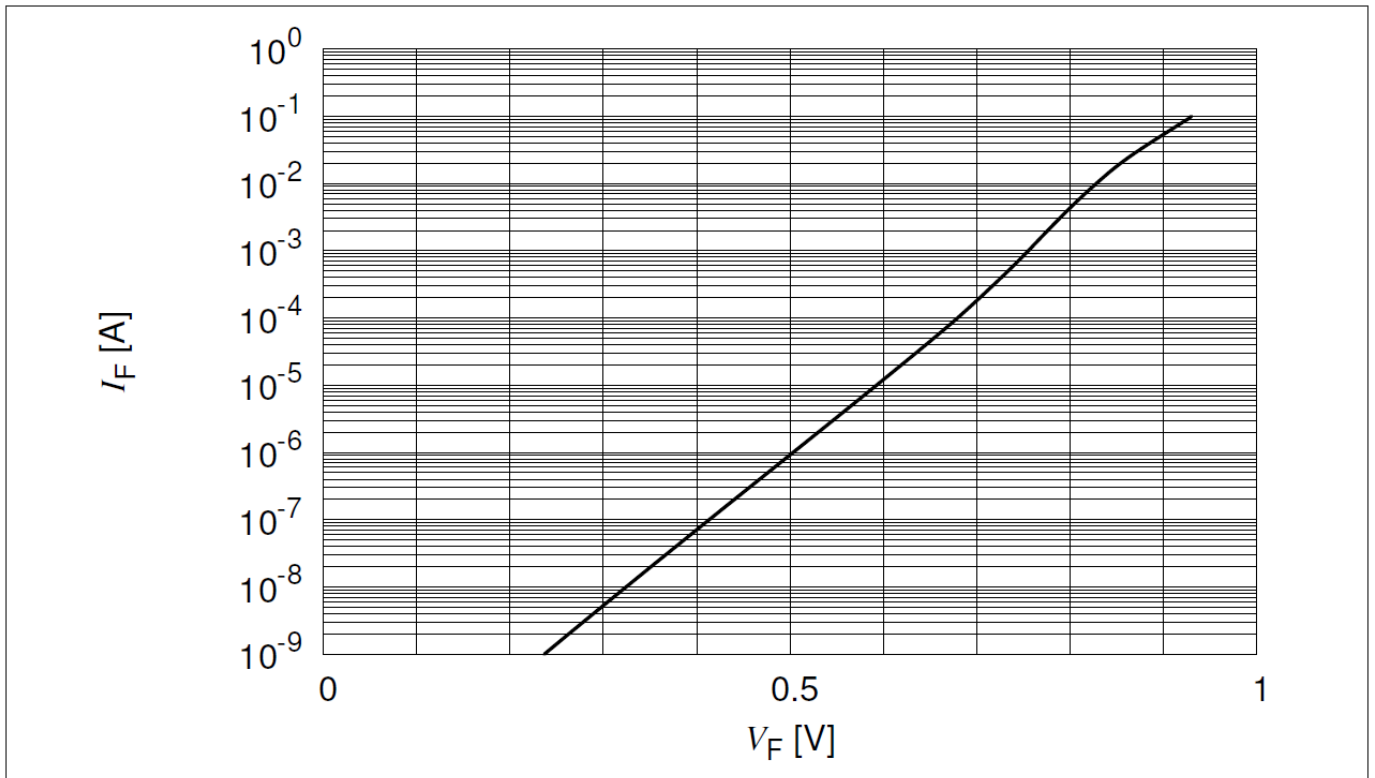

Figure 6 Forward characteristic, $I_F = f(V_F)$, current forced

Typical characteristic diagrams

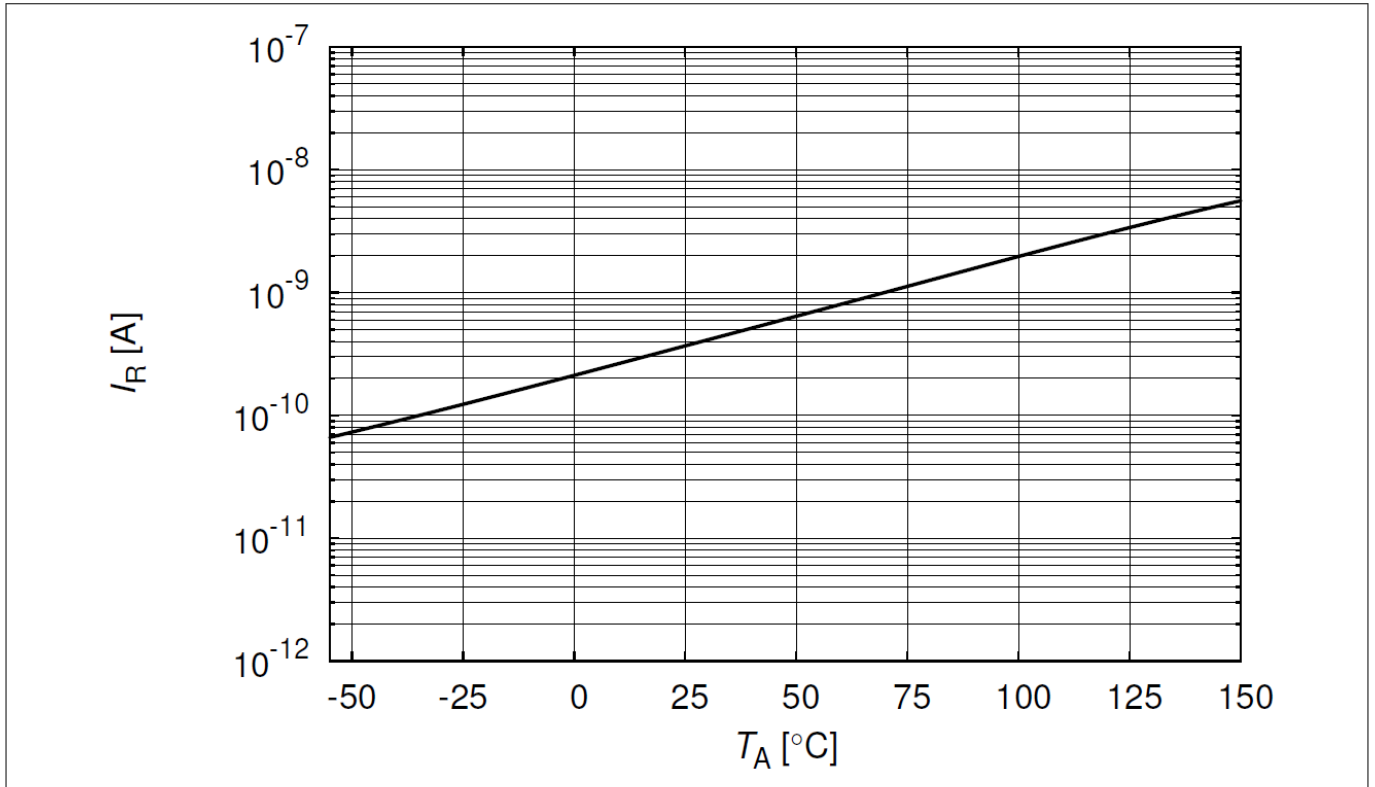

Figure 7 Reverse current $I_R = f(T_A)$, $V_R = 5.5$ V (typical)

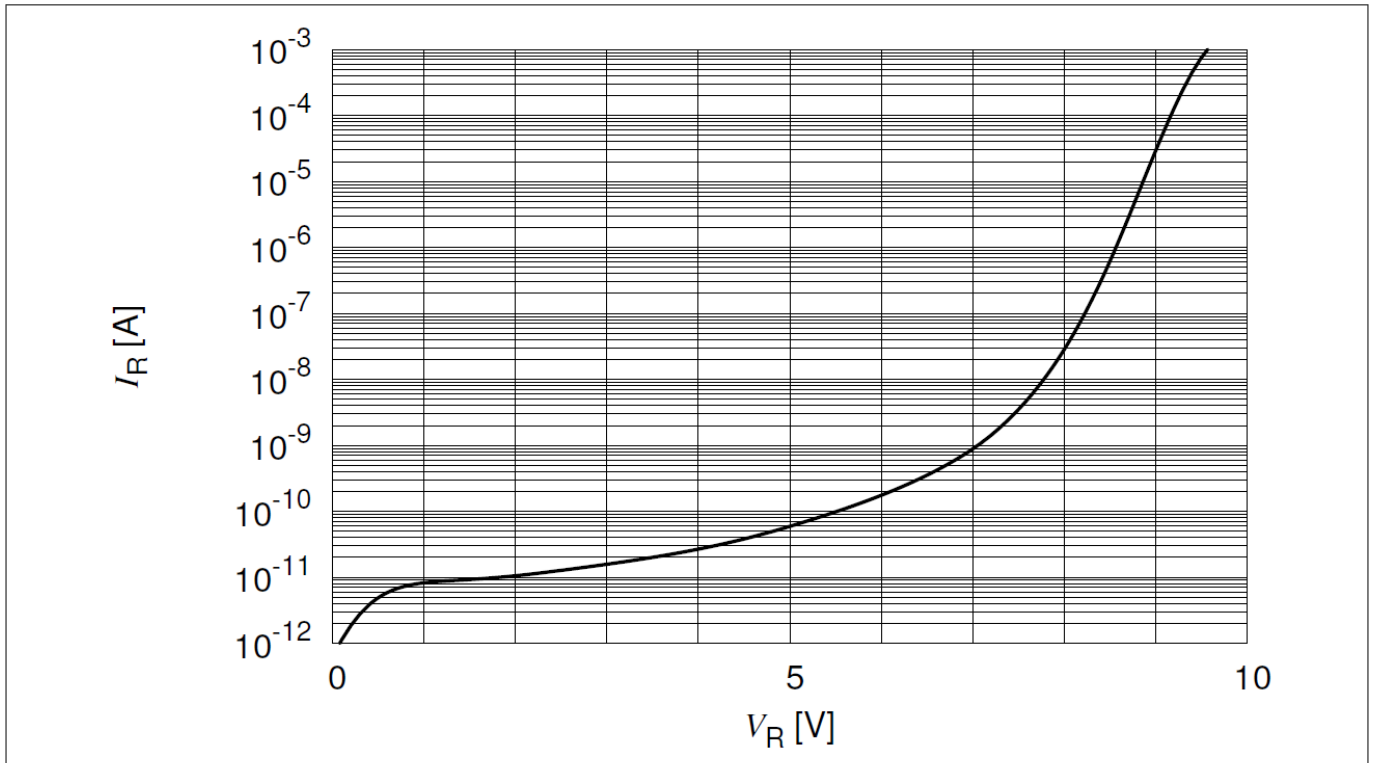

Figure 8 Reverse characteristic, $I_R = f(V_R)$, voltage forced

Typical characteristic diagrams

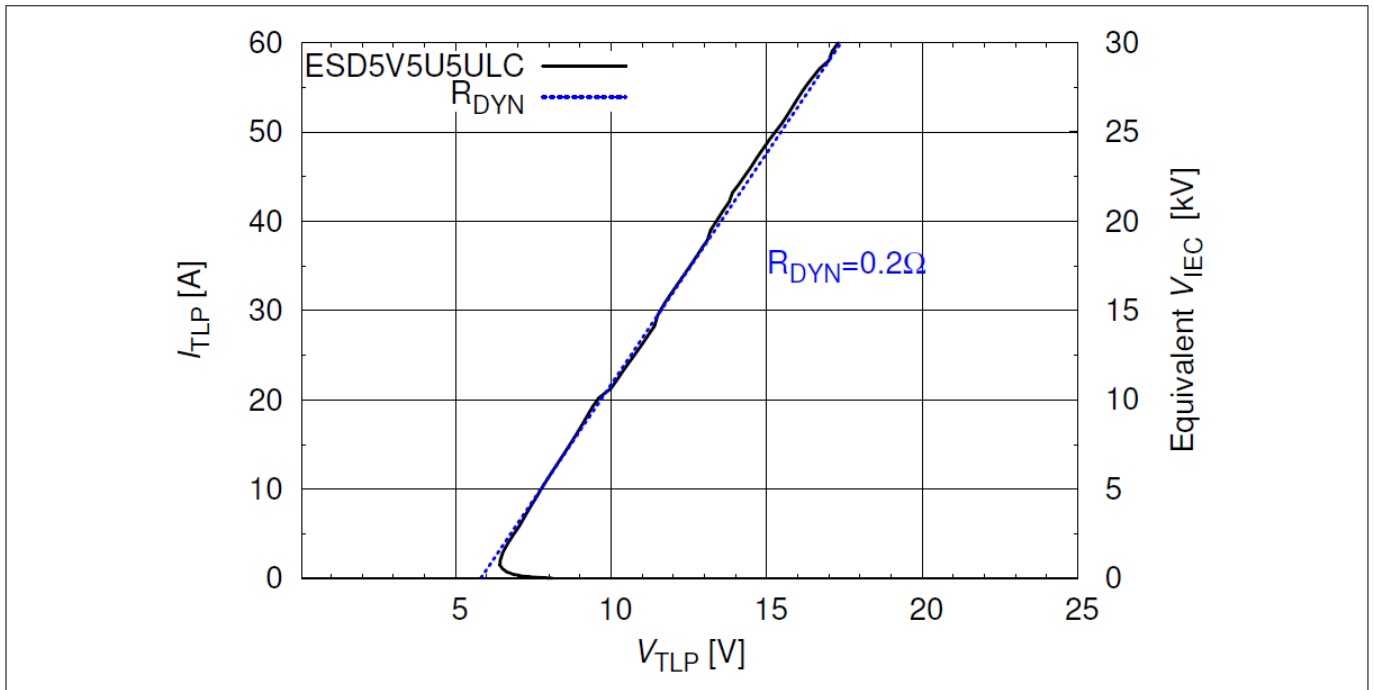

Figure 9 TLP characteristic I/O to GND ¹⁾ [1]

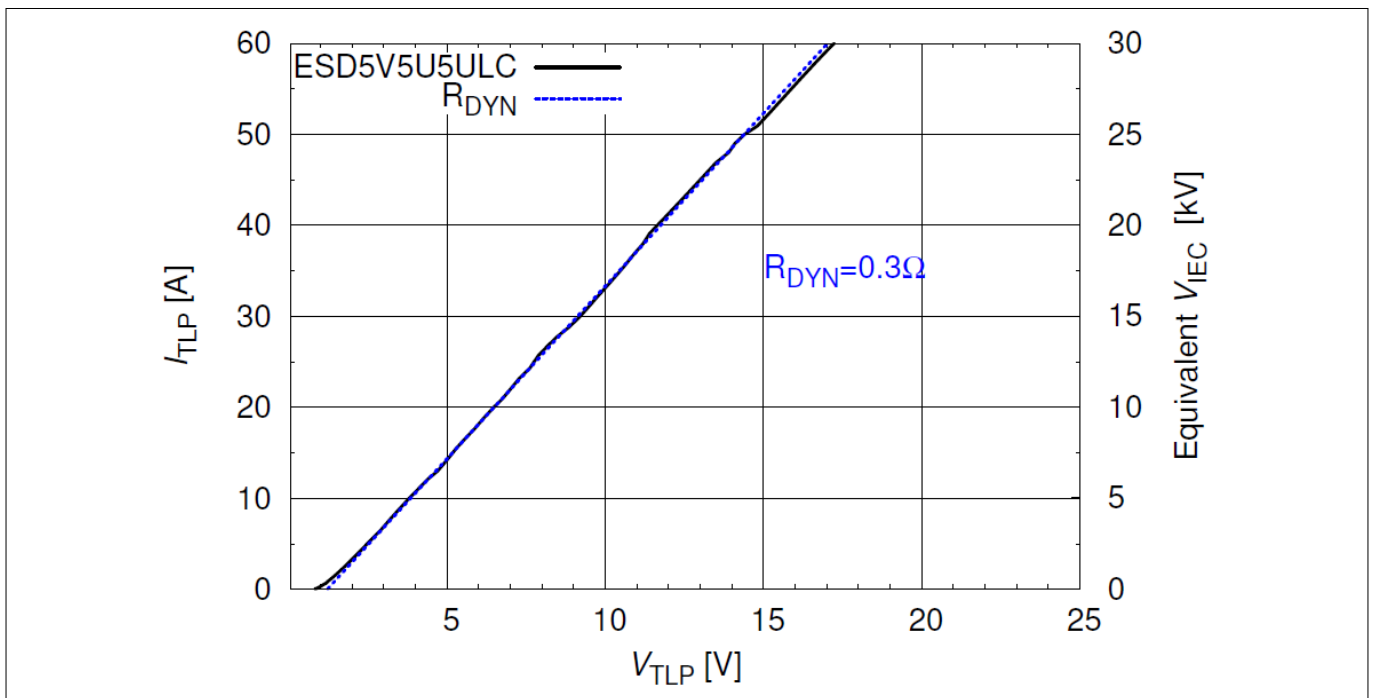

Figure 10 TLP characteristic GND to I/O ¹⁾ [1]

¹ TLP parameter: $Z_0 = 50 \Omega$, $t_p = 100 \text{ ns}$, $t_r = 300 \text{ ps}$, averaging window: $t_1 = 30 \text{ ns}$ to $t_2 = 60 \text{ ns}$, extraction of dynamic resistance using least squares fit of TLP characteristic between $I_{PP1} = 10 \text{ A}$ and $I_{PP2} = 40 \text{ A}$. The equivalent stress level V_{IEC} according IEC61000-4-2 ($R = 330 \Omega$, $C = 150 \text{ pF}$) is calculated at the broad peak of the IEC waveform at $t = 30 \text{ ns}$ with 2 A/kV .

Application information

4 Application information

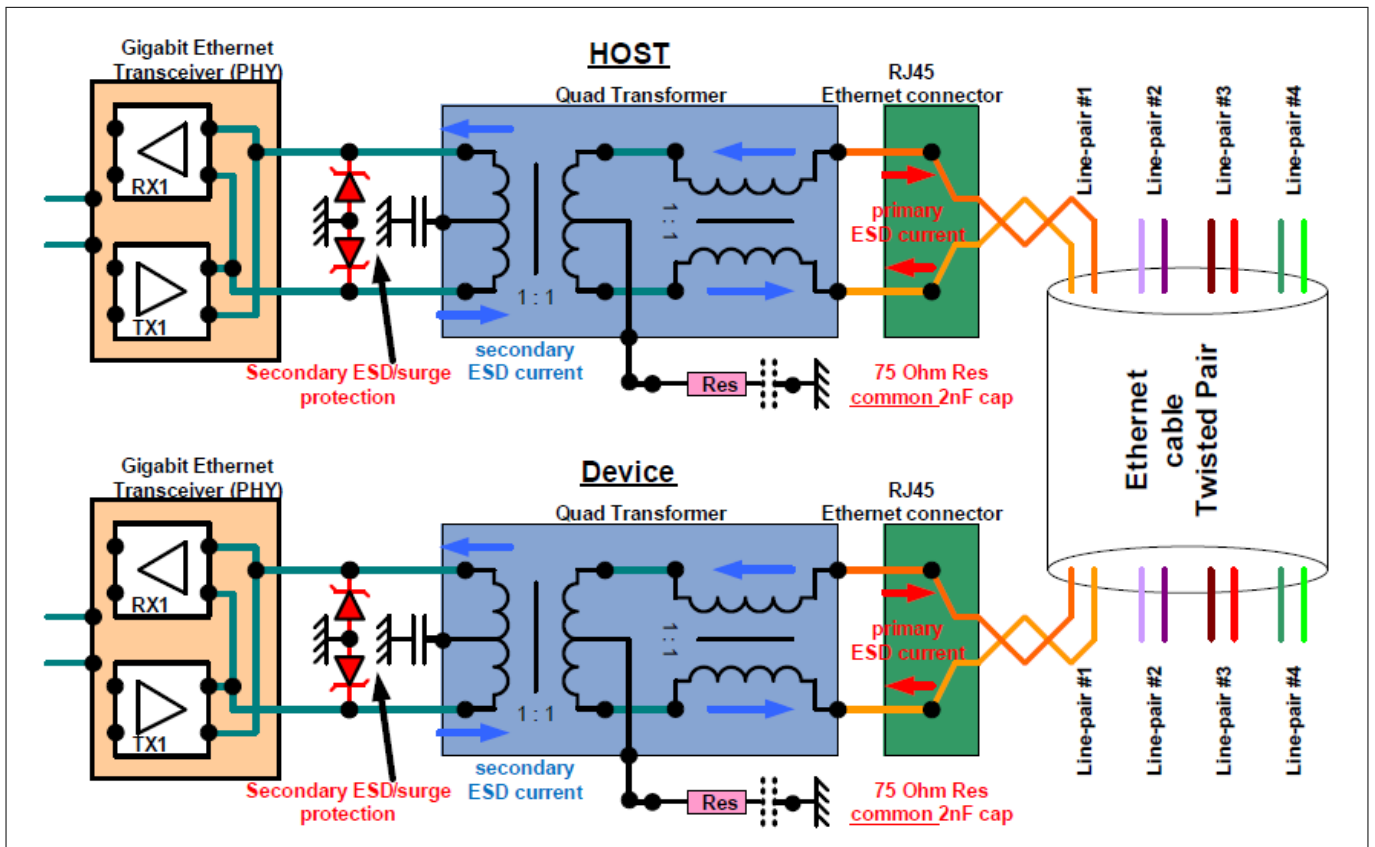

Figure 11 Ethernet

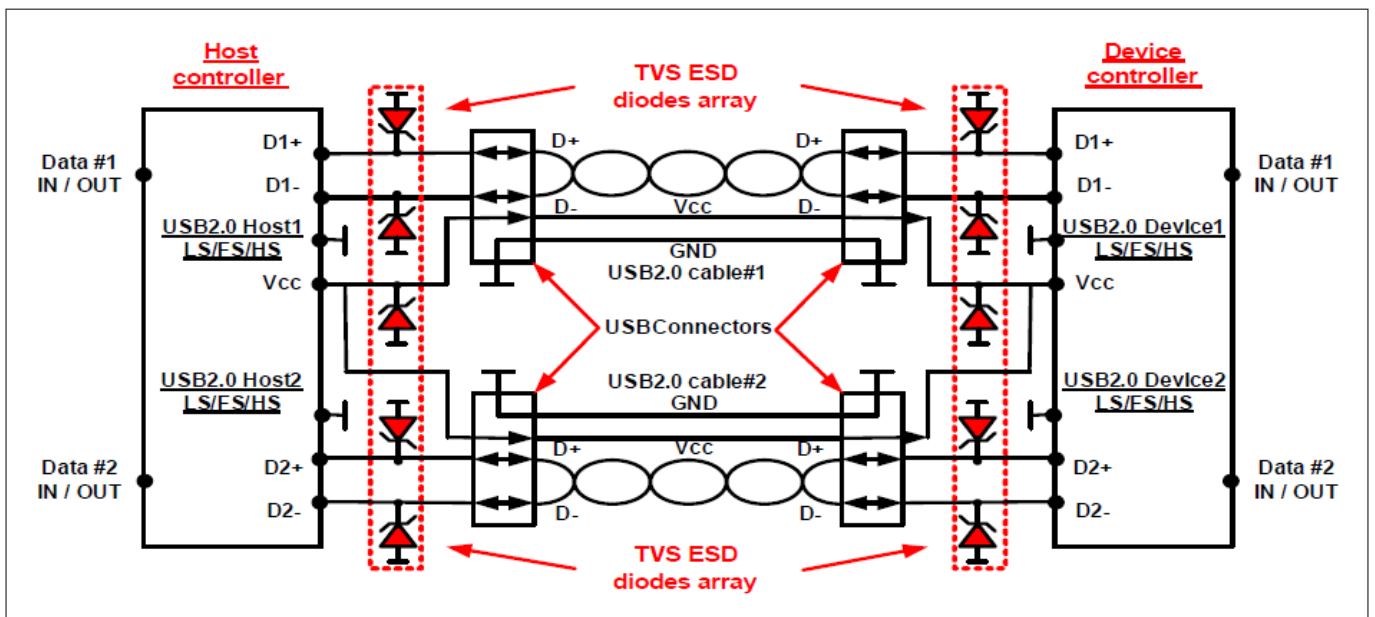

Figure 12 USB2.0

Package information

5 Package information

Note: Dimensions in mm.

5.1 PG-SC74-6-2 package

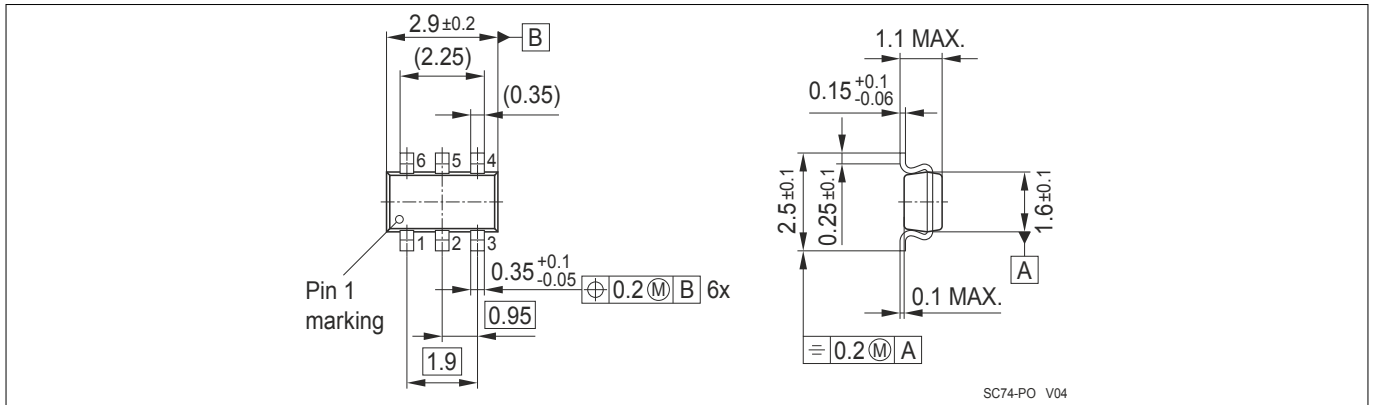

Figure 13 PG-SC74-6-2 package overview

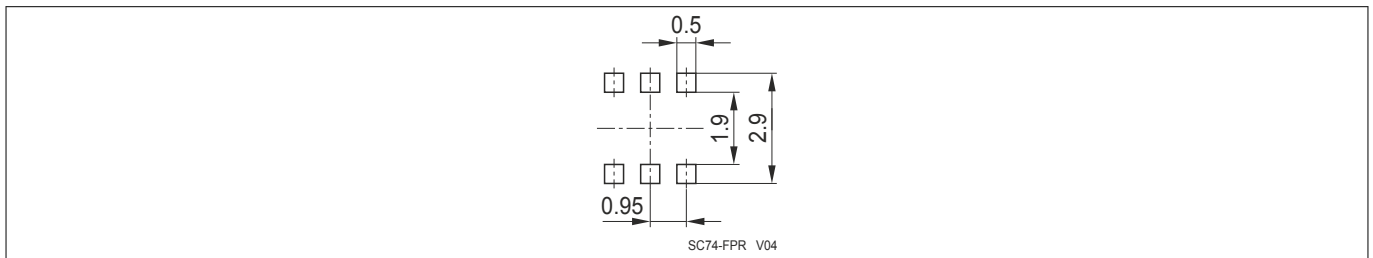

Figure 14 PG-SC74-6-2 footprint

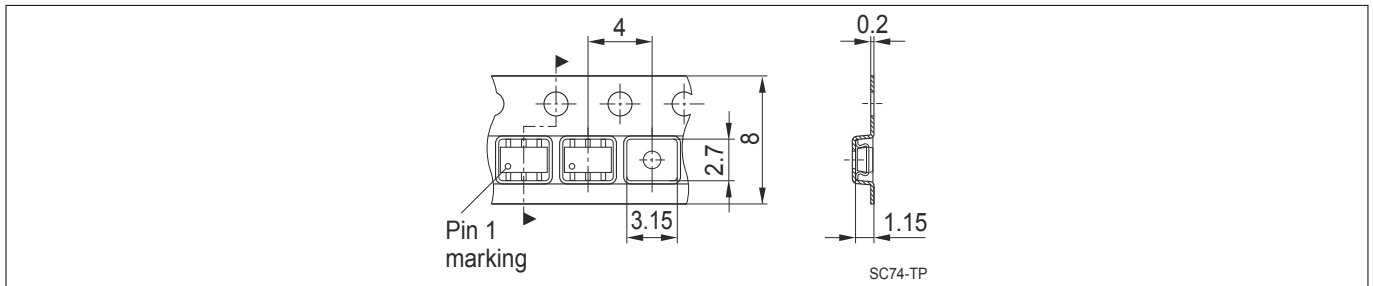

Figure 15 PG-SC74-6-2 packing

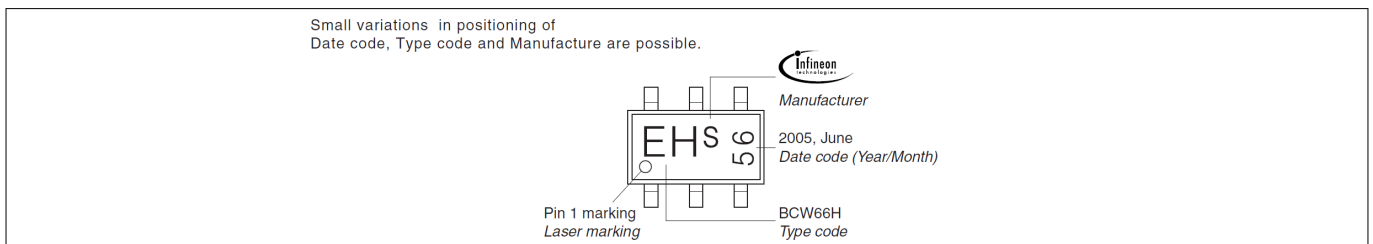

Figure 16 PG-SC74-6-2 marking example (see [Device information](#))

References

6 References

- [1] Infineon AG - **Application Note AN210**: Effective ESD protection design at system level using VF-TLP characterization methodology

Revision history

Revision history: Rev. 1.4. 2016-04-21

Page or Item	Subjects (major changes since previous revision)
Revision 1.5, 2018-06-12	
All	Data sheet layout changed, references updated, ordering information scheme deleted

Trademarks

All referenced product or service names and trademarks are the property of their respective owners.

Edition 2018-06-12

Published by
Infineon Technologies AG
81726 Munich, Germany

© 2018 Infineon Technologies AG
All Rights Reserved.

Do you have a question about any
aspect of this document?
Email: erratum@infineon.com

Document reference
IFX-rkd1513342948700

IMPORTANT NOTICE

The information given in this document shall in no event be regarded as a guarantee of conditions or characteristics ("Beschaffheitsgarantie").

With respect to any examples, hints or any typical values stated herein and/or any information regarding the application of the product, Infineon Technologies hereby disclaims any and all warranties and liabilities of any kind, including without limitation warranties of non-infringement of intellectual property rights of any third party.

In addition, any information given in this document is subject to customer's compliance with its obligations stated in this document and any applicable legal requirements, norms and standards concerning customer's products and any use of the product of Infineon Technologies in customer's applications.

The data contained in this document is exclusively intended for technically trained staff. It is the responsibility of customer's technical departments to evaluate the suitability of the product for the intended application and the completeness of the product information given in this document with respect to such application.

WARNINGS

Due to technical requirements products may contain dangerous substances. For information on the types in question please contact your nearest Infineon Technologies office.

Except as otherwise explicitly approved by Infineon Technologies in a written document signed by authorized representatives of Infineon Technologies, Infineon Technologies' products may not be used in any applications where a failure of the product or any consequences of the use thereof can reasonably be expected to result in personal injury

Looking for pricing, stock, or lifecycle information?

Click below to explore more details on WIN SOURCE:

- ⊖ [View ESD5V5U5ULCE6327HTSA1 on WIN SOURCE](#)
- ⊖ [Infineon Technologies Information](#)

Optimize Your Supply Chain with WIN SOURCE Solutions

- ✓ Global Sourcing Solution
- ✓ Obsolete Management
- ✓ Cost Control Management
- ✓ Shortage Management
- ✓ Alternative Solution
- ✓ Excess Inventory Management