



# THE DATASHEET OF STTA812DIRG



## TURBOSWITCH ULTRA-FAST HIGH VOLTAGE DIODE

### MAIN PRODUCT CHARACTERISTICS

$I_{F(AV)}$	8A
$V_{RRM}$	1200V
$t_{rr} (typ)$	50ns
$V_F (max)$	2.0V

### FEATURES AND BENEFITS

- ULTRA-FAST, SOFT RECOVERY.
- VERY LOW OVERALL POWER LOSSES IN BOTH THE DIODE AND THE COMPANION TRANSISTOR.
- HIGH FREQUENCY AND/OR HIGH PULSED CURRENT OPERATION.
- HIGH REVERSE VOLTAGE CAPABILITY
- INSULATED PACKAGE : TO-220AC Ins.  
Electrical insulation : 2500V<sub>RMS</sub>  
Capacitance : 7pF.

### DESCRIPTION

TURBOSWITCH 1200V drastically cuts losses in all high voltage operations which require extremely fast, soft and noise-free power diodes. Due to their optimized switching performances they also highly decrease power losses in any associated switching IGBT or MOSFET in all "freewheel mode" operations.

### ABSOLUTE RATINGS (limiting values)

Sym. bcl	Parameter	Value	Unit
$V_{RRM}$	Repetitive peak reverse voltage	1200	V
$V_{RSM}$	Non repetitive peak reverse voltage	1200	V
$I_{F(RMS)}$	RMS forward current	TO-220AC/ D <sup>2</sup> PAK	30 A
		TO-220AC Ins.	20 A
$I_{FRM}$	Repetitive peak forward current	$t_p = 5 \mu s$ F = 5kHz square	110 A
$I_{FSM}$	Surge non repetitive forward current	$t_p = 10ms$ sinusoidal	70 A
$T_{stg}$	Storage temperature range	- 65 to + 150	°C
$T_j$	Maximum operating junction temperature	150	°C

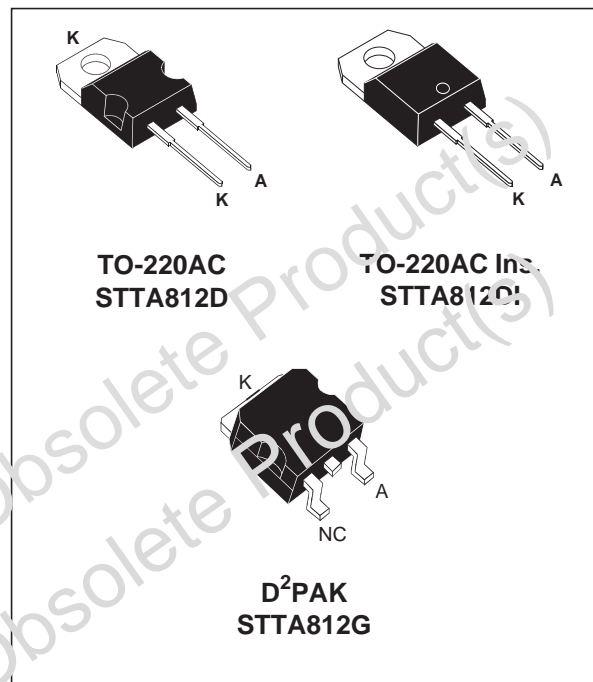

They are particularly suitable in motor control circuitries, or in the primary of SMPS as snubber, clamping or demagnetizing diodes. They are also suitable for secondary of SMPS as high voltage rectifier diodes.

## STTA812D/DI/G

### THERMAL AND POWER DATA

Symbol	Parameter	Conditions	Value	Unit
$R_{th(j-c)}$	Junction to case thermal resistance	TO-220AC/D <sup>2</sup> PAK TO-220AC Ins.	2.3 3.3	°C/W
$P_1$	Conduction power dissipation $I_{F(AV)} = 8A$ $\delta = 0.5$	TO-220AC/D <sup>2</sup> PAK TO-220AC Ins.	$T_c = 105^\circ C$ $T_c = 85^\circ C$	W
$P_{max}$	Total power dissipation $P_{max} = P_1 + P_3$ ( $P_3 = 10\%$ $P_1$ )	TO-220AC/D <sup>2</sup> PAK TO-220AC Ins.	$T_c = 100^\circ C$ $T_c = 79^\circ C$	W

### STATIC ELECTRICAL CHARACTERISTICS

Symbol	Parameter	Test conditions	Min	Typ	Max	Unit
$V_F^*$	Forward voltage drop	$I_F = 8A$ $T_j = 25^\circ C$ $T_j = 125^\circ C$			2.2	V
				1.35	2.0	V
$I_R^{**}$	Reverse leakage current	$V_R = 0.8 \times V_{RRM}$ $T_j = 25^\circ C$ $T_j = 125^\circ C$			100	$\mu A$
				0.6	4	mA
$V_{to}$	Threshold voltage	$I_p < 3 \cdot I_{AV}$ $T_j = 125^\circ C$			1.57	V
$r_d$	Dynamic parameter				54	m $\Omega$

Test pulses : \*  $t_p = 380 \mu s$ ,  $\delta < 2\%$   
 \*\*  $t_p = 5 ms$ ,  $\delta < 2\%$

To evaluate the maximum conduction losses use the following equation :  
 $P = V_{to} \times I_{F(AV)} + r_d \times I_F^2(RMS)$

### DYNAMIC ELECTRICAL CHARACTERISTICS

#### TURN-OFF SWITCHING

Symbol	Parameter	Test conditions	Min	Typ	Max	Unit
$t_{rr}$	Reverse recovery time	$T_j = 25^\circ C$ $I_F = 0.5 A$ $I_R = 1A$ $I_{rr} = 0.25A$ $I_F = 1 A$ $di_F/dt = -50A/\mu s$ $V_R = 30V$		50	100	ns
$i_{RM}$	Maximum reverse recovery current	$T_j = 125^\circ C$ $V_R = 600V$ $I_F = 8A$ $di_F/dt = -64 A/\mu s$ $di_F/dt = -500 A/\mu s$		25	12	A
S factor	Softness factor	$T_j = 125^\circ C$ $V_R = 600V$ $I_F = 8A$ $di_F/dt = -500 A/\mu s$		1.2		-

#### TURN-ON SWITCHING

Symbol	Parameter	Test conditions	Min	Typ	Max	Unit
$t_{fr}$	Forward recovery time	$T_j = 25^\circ C$ $I_F = 8 A$ , $di_F/dt = 64 A/\mu s$ measured at $1.1 \times V_{Fmax}$			900	ns
$V_{FP}$	Peak forward voltage	$T_j = 25^\circ C$ $I_F = 8A$ , $di_F/dt = 64 A/\mu s$ $I_F = 40A$ , $di_F/dt = 500 A/\mu s$		45	35	V

**Fig. 1:** Conduction losses versus average current.

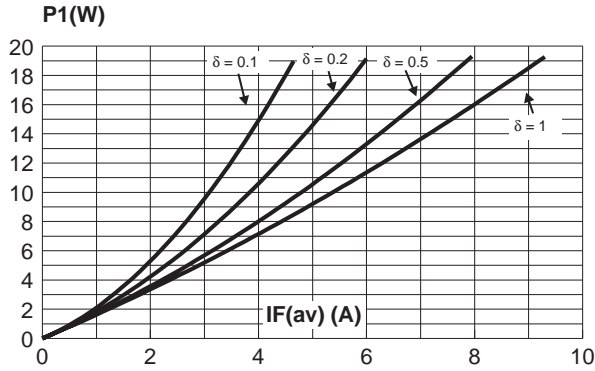

**Fig. 2:** Forward voltage drop versus forward current (maximum values).

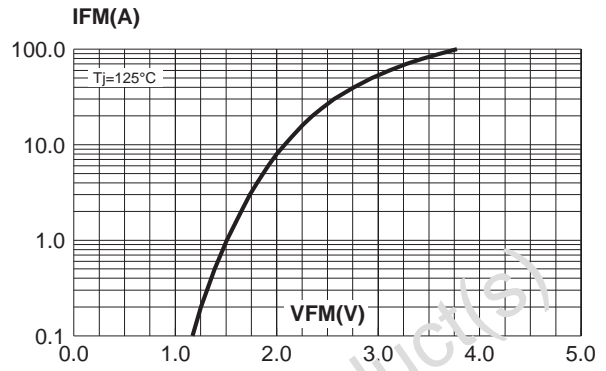

**Fig. 3:** Relative variation of thermal impedance junction to case versus pulse duration.

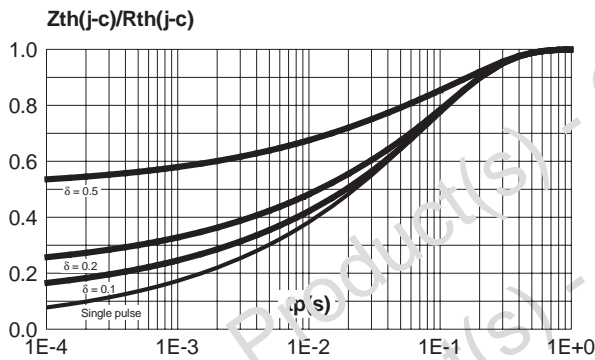

**Fig. 4:** Peak reverse recovery current versus  $dI_F/dt$  (90% confidence).

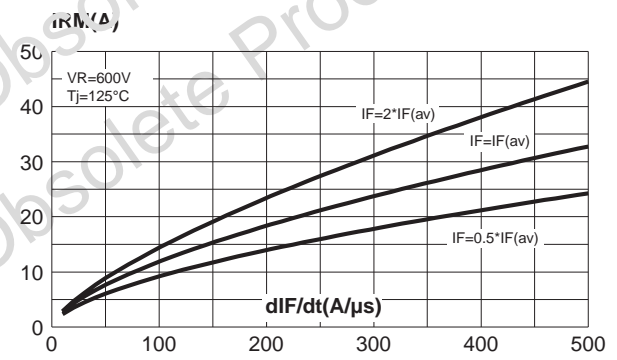

**Fig. 5:** Reverse recovery time versus  $dI_F/dt$  (90% confidence).

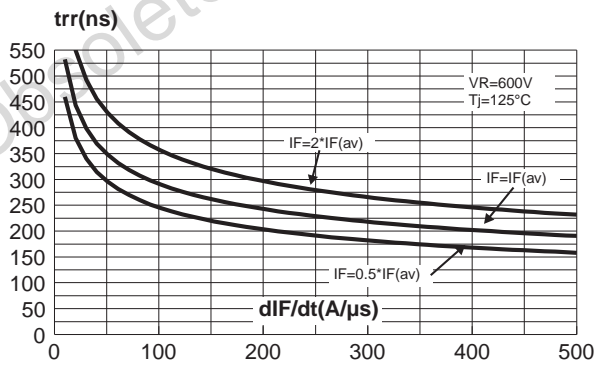

**Fig. 6:** Softness factor (tb/ta) versus  $dI_F/dt$  (typical values).

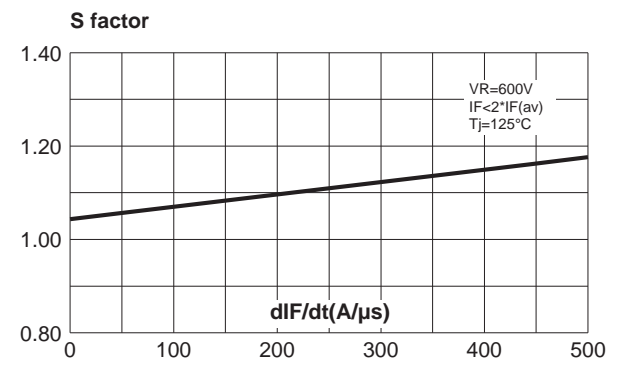

**Fig. 7:** Relative variation of dynamic parameters versus junction temperature (reference  $T_j=125^\circ\text{C}$ ).

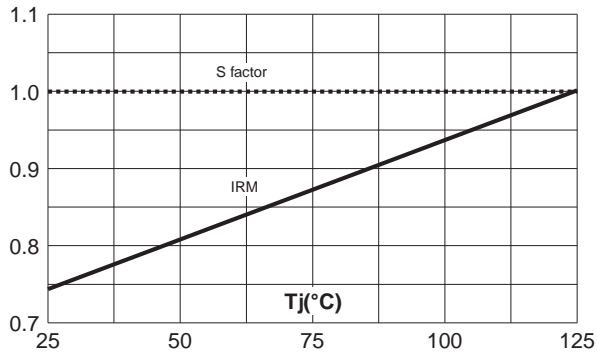

**Fig.8:** Transient peak forward voltage versus  $dI_F/dt$  (90% confidence).

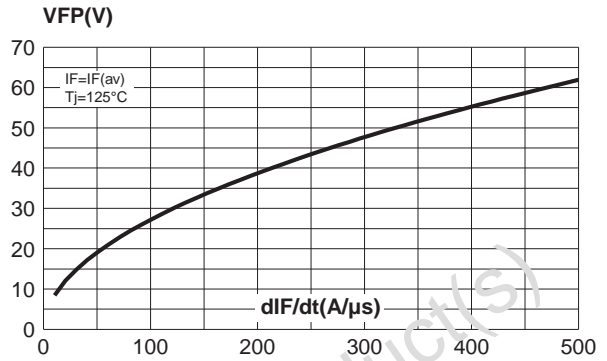

**Fig. 9:** Forward recovery time versus  $dI_F/dt$  (90% confidence).

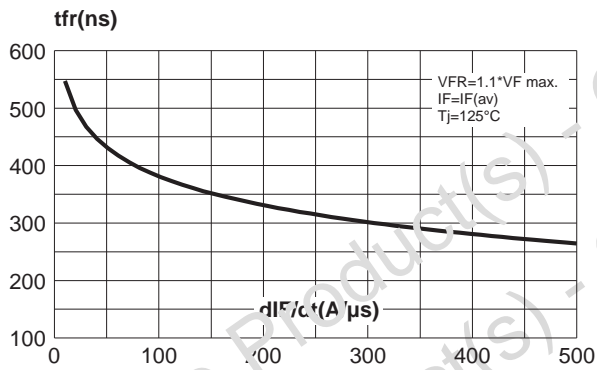

## APPLICATION DATA

The 1200V TURBOSWITCH series has been designed to provide the lowest overall power losses in all high frequency or high pulsed current operations. In such applications (Fig A to D), the way of calculating the power losses is given below :

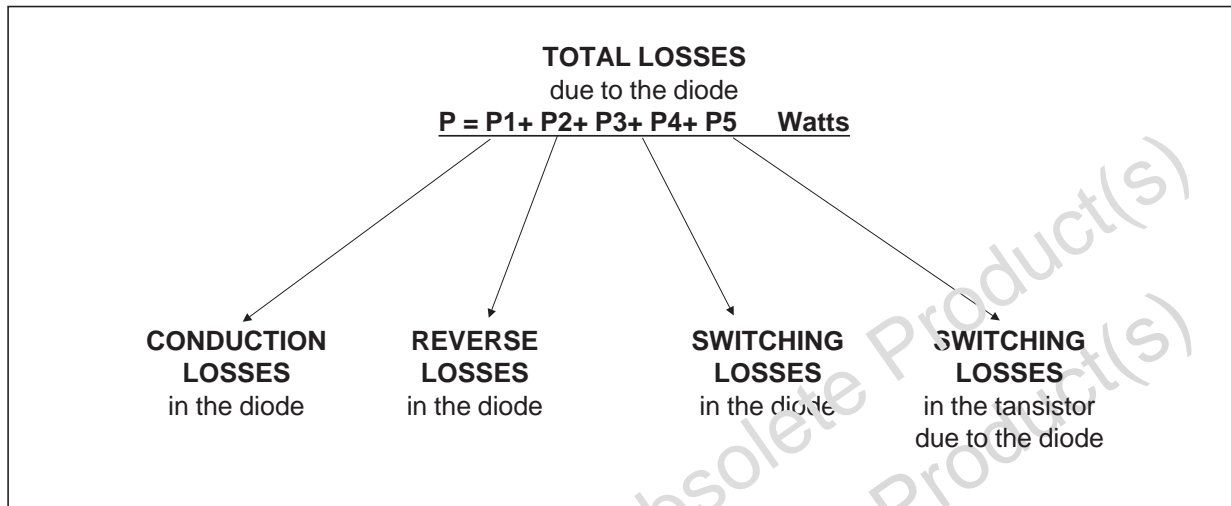

Fig. A: "FREEWHEEL" MODE.

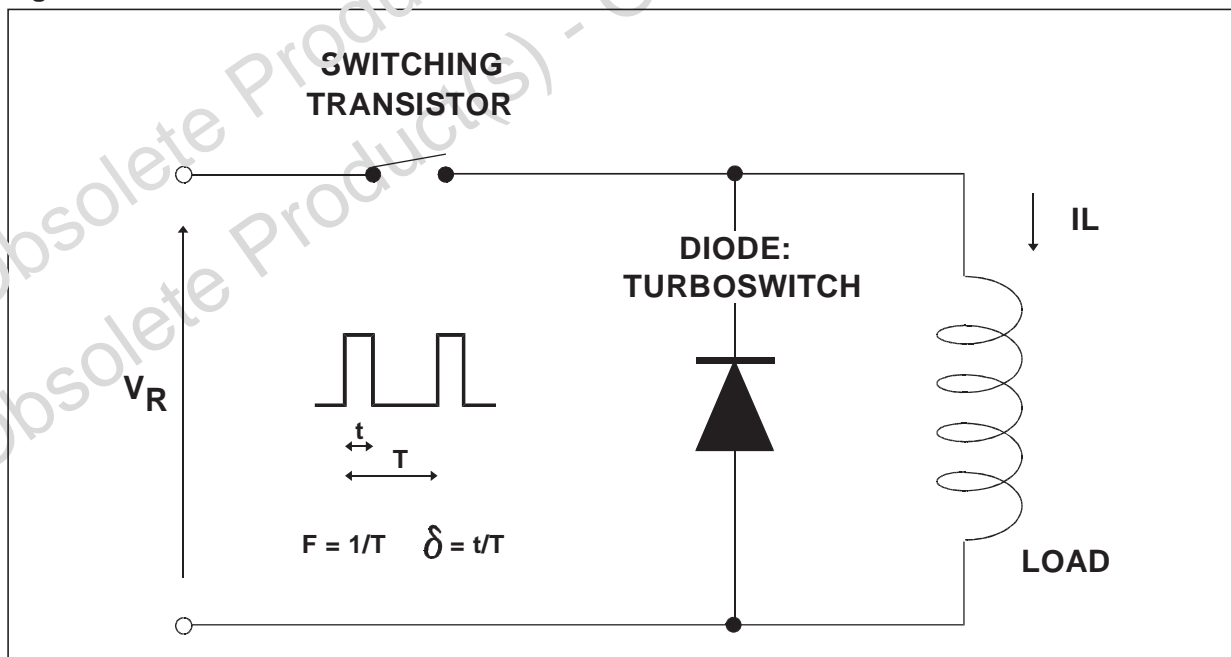

Fig. B: SNUBBER DIODE.

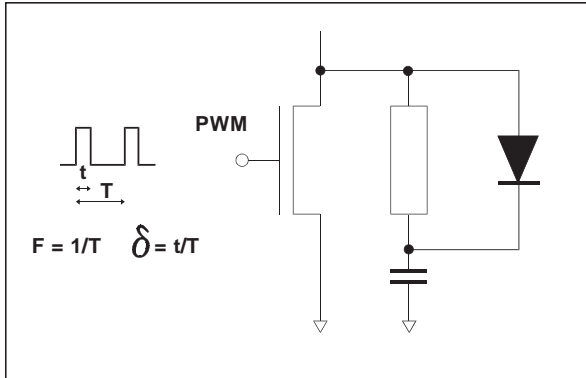

Fig. C: DEMAGNETIZING DIODE.

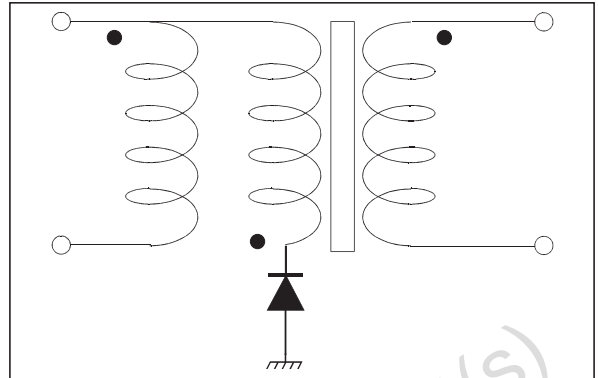
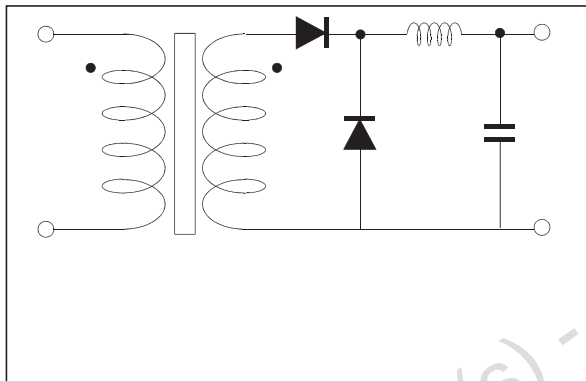
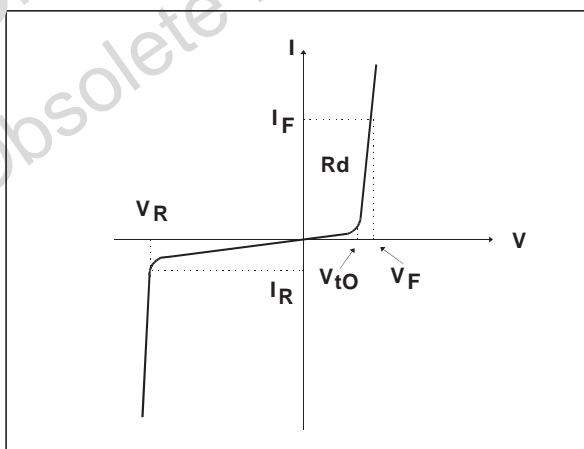

Fig. D: RECTIFIER DIODE.



STAT C & DYNAMIC CHARACTERISTICS . POWER LOSSES .

Fig. E: STATIC CHARACTERISTICS



**Conduction losses :**

$$P1 = V_{t0} \cdot I_{F(AV)} + R_d \cdot I_{F(RMS)}^2$$

**Reverse losses :**

$$P2 = V_R \cdot I_R \cdot (1 - \delta)$$

APPLICATION DATA (Cont'd)

Fig. F: TURN-OFF CHARACTERISTICS

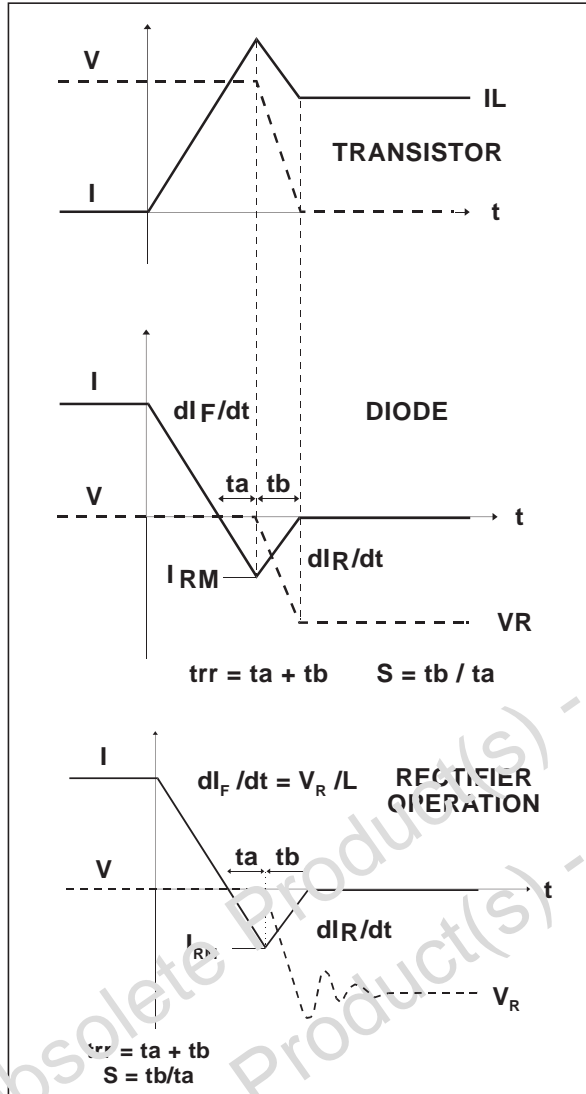
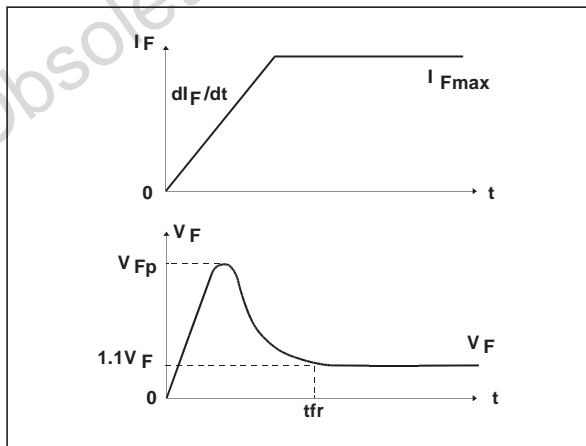

Fig. G: TURN-ON CHARACTERISTICS



Turn-on losses :  
(in the transistor, due to the diode)

$$P5 = \frac{V_R \times I_{RM}^2 \times (3 + 2 \times S) \times F}{6 \times dI_F / dt} + \frac{V_R \times I_{RM} \times I_L \times (S + 2) \times F}{2 \times dI_F / dt}$$

Turn-off losses (in the diode) :

$$P3 = \frac{V_R \times I_{RM}^2 \times S \times F}{6 \times dI_F / dt}$$

Turn-off losses :  
(with non negligible serial inductance)

$$P3' = \frac{V_R \times I_{RM}^2 \times S \times F}{6 \times dI_F / dt} + \frac{L \times I_{RM}^2 \times F}{2}$$

P3,P3' and P5 are suitable for power MOSFET and IGBT

Turn-on losses :

$$P4 = 0.4 (V_{FP} - V_F) \cdot I_{Fmax} \cdot t_{fr} \cdot F$$

**PACKAGE DATA**  
TO-220AC Ins.

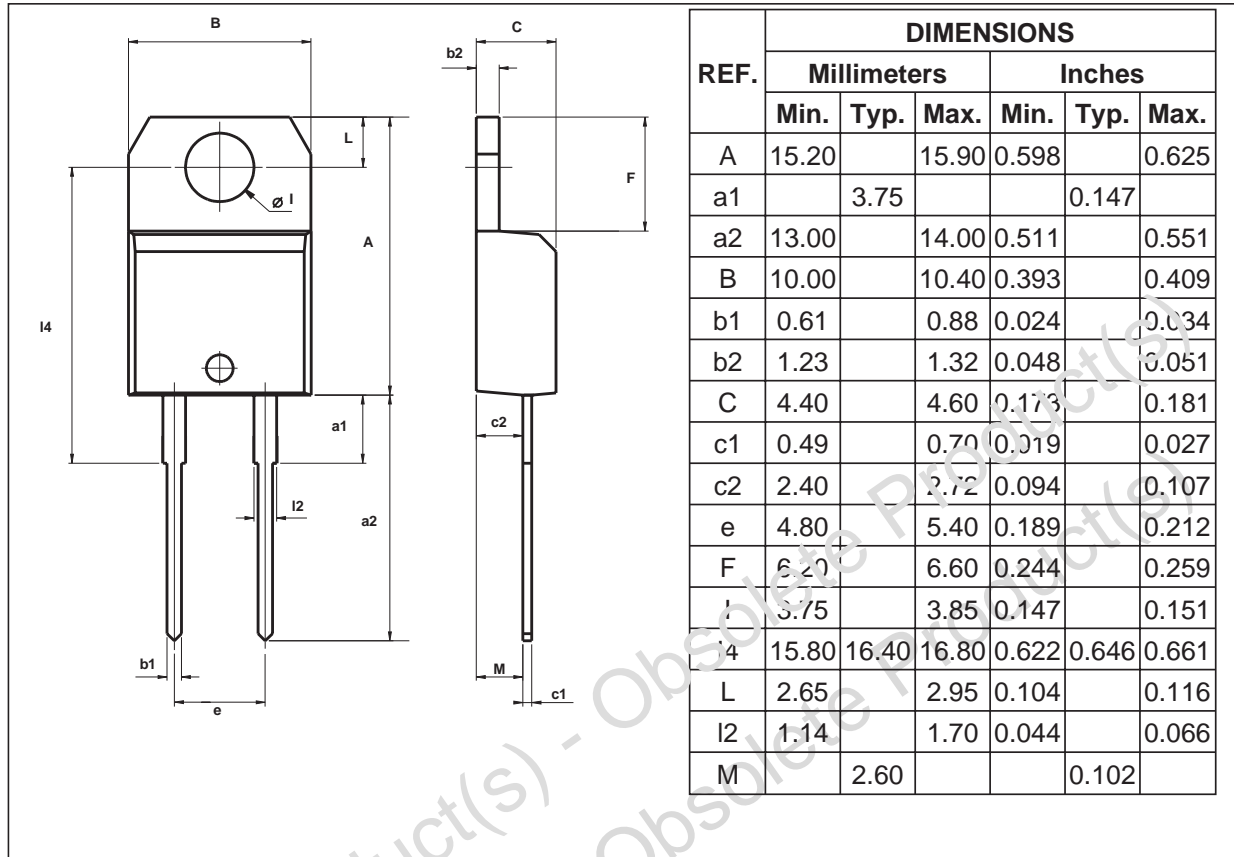

- Cooling method: by conduction (C)
- Recommended torque value: 0.8 m.N
- Maximum torque value: 1.0 m.N

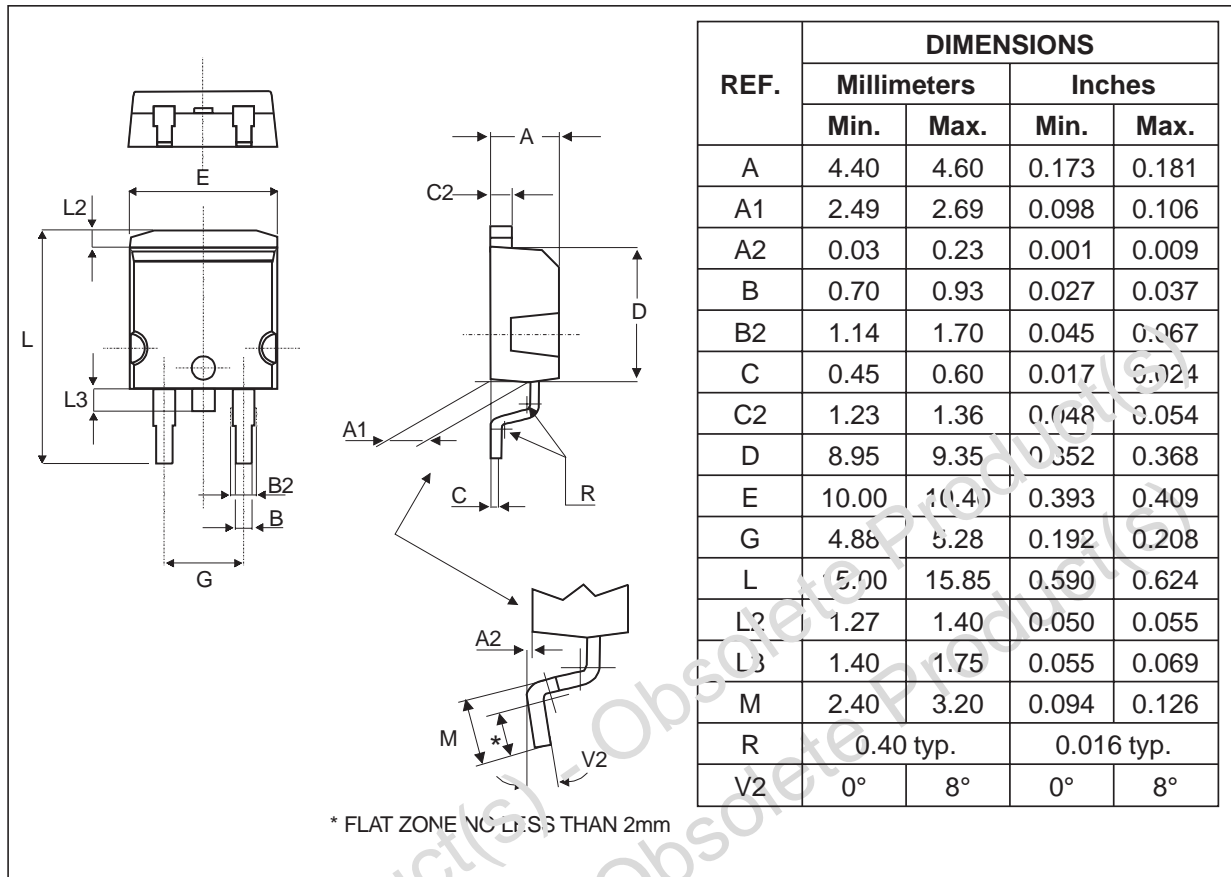
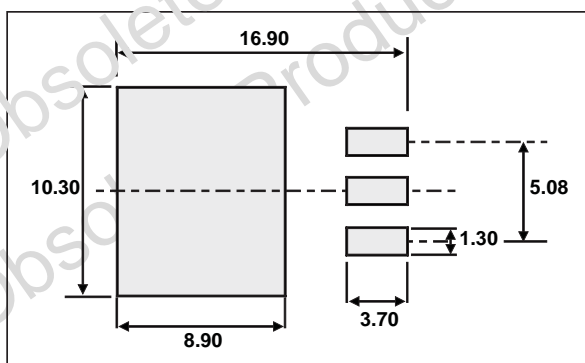
**PACKAGE DATA**  
**D<sup>2</sup>PAK**

**FOOTPRINT DIMENSIONS (in millimeters)**

# STTA812D/DI/G

## PACKAGE DATA

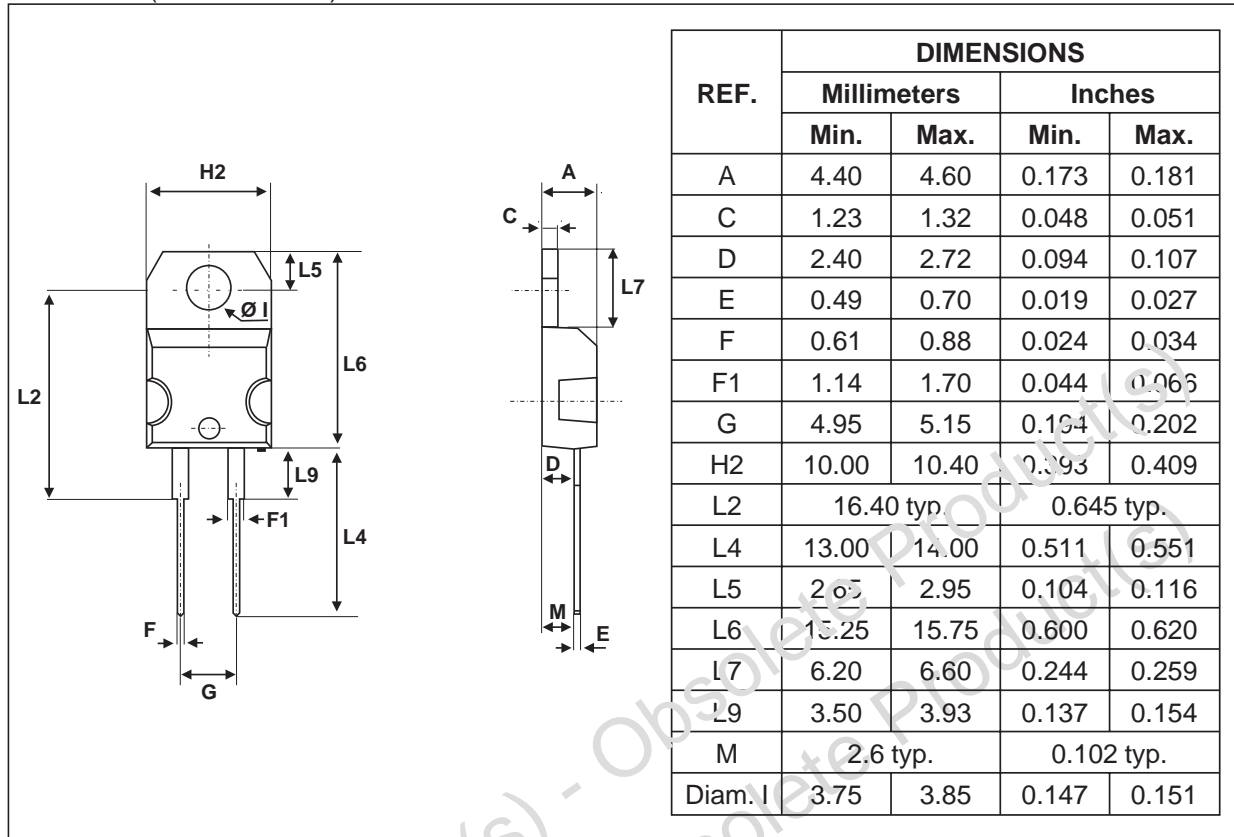
TO-220AC (JEDEC outline)



- Cooling method: by conduction (C)
- Recommended torque value: 0.55 m.N
- Maximum torque value: 0.7 m.N

Ordering type	Marking	Package	Weight	Base qty	Delivery mode
STTA812D	STTA812D	TO-220AC	1.86g	50	Tube
STTA812DI	STTA812DI	TO-220AC Ins.	1.86g	250	Bulk
STTA812G	STTA812G	D <sup>2</sup> PAK	1.48g	50	Tube
STTA812G-TR	STTA812G	D <sup>2</sup> PAK	1.48g	500	Tape & reel

- Epoxy meets UL94,V0

Information furnished is believed to be accurate and reliable. However, STMicroelectronics assumes no responsibility for the consequences of use of such information nor for any infringement of patents or other rights of third parties which may result from its use. No license is granted by implication or otherwise under any patent or patent rights of STMicroelectronics. Specifications mentioned in this publication are subject to change without notice. This publication supersedes and replaces all information previously supplied. STMicroelectronics products are not authorized for use as critical components in life support devices or systems without express written approval of STMicroelectronics.

The ST logo is a registered trademark of STMicroelectronics  
 © 2002 STMicroelectronics - Printed in Italy - All rights reserved.  
 STMicroelectronics GROUP OF COMPANIES  
 Australia - Brazil - Canada - China - Finland - France - Germany  
 Hong Kong - India - Israel - Italy - Japan - Malaysia - Malta - Morocco - Singapore  
 Spain - Sweden - Switzerland - United Kingdom - United States.

<http://www.st.com>



## Looking for pricing, stock, or lifecycle information?

Click below to explore more details on WIN SOURCE:

 [View STTA812DIRG](#) on WIN SOURCE

 [STMicroelectronics](#) Information

## Optimize Your Supply Chain with WIN SOURCE Solutions

-  Global Sourcing Solution
-  Obsolete Management
-  Cost Control Management
-  Shortage Management
-  Alternative Solution
-  Excess Inventory Management