



**THE DATASHEET OF
AD604ARZ-RL**



FEATURES

- Ultralow input noise at maximum gain**
0.80 nV/ $\sqrt{\text{Hz}}$, 3.0 pA/ $\sqrt{\text{Hz}}$
- 2 independent linear-in-dB channels**
- Absolute gain range per channel programmable**
0 dB to 48 dB (preamplifier gain = 14 dB) through 6 dB to 54 dB (preamplifier gain = 20 dB)
- ± 1.0 dB gain accuracy**
- Bandwidth: 40 MHz (-3 dB)**
- Input resistance: 300 k Ω**
- Variable gain scaling: 20 dB/V through 40 dB/V**
- Stable gain with temperature and supply variations**
- Single-ended unipolar gain control**
- Power shutdown at lower end of gain control**
- Drive ADCs directly**

APPLICATIONS

- Ultrasound and sonar time-gain controls**
- High performance AGC systems**
- Signal measurement**

GENERAL DESCRIPTION

The AD604 is an ultralow noise, very accurate, dual-channel, linear-in-dB variable gain amplifier (VGA) optimized for time-based variable gain control in ultrasound applications; however, it supports any application requiring low noise, wide bandwidth, variable gain control. Each channel of the AD604 provides a 300 k Ω input resistance and unipolar gain control for ease of use. User-determined gain ranges, gain scaling (dB/V), and dc level shifting of output further optimize performance.

Each channel of the AD604 uses a high performance preamplifier that provides an input-referred noise voltage of 0.8 nV/ $\sqrt{\text{Hz}}$. The very accurate linear-in-dB response of the AD604 is achieved with the differential input exponential amplifier (DSX-AMP) architecture. Each DSX-AMP comprises a variable attenuator of 0 dB to 48.36 dB followed by a high speed fixed-gain amplifier. The attenuator is a 7-stage R-1.5R ladder network. The attenuation between tap points is 6.908 dB and 48.36 dB for the ladder network.

The equation for the linear-in-dB gain response is

$$G \text{ (dB)} = (\text{Gain Scaling (dB/V)} \times \text{VGN (V)}) + (\text{Preamp Gain (dB)} - 19 \text{ dB})$$

Rev. G

Information furnished by Analog Devices is believed to be accurate and reliable. However, no responsibility is assumed by Analog Devices for its use, nor for any infringements of patents or other rights of third parties that may result from its use. Specifications subject to change without notice. No license is granted by implication or otherwise under any patent or patent rights of Analog Devices. Trademarks and registered trademarks are the property of their respective owners.

FUNCTIONAL BLOCK DIAGRAM

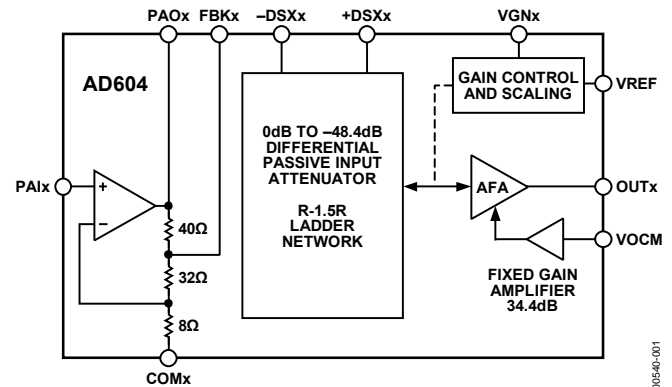

Figure 1.

Preamplifier gains between 5 and 10 (14 dB and 20 dB) provide overall gain ranges per channel of 0 dB through 48 dB and 6 dB through 54 dB. The two channels of the AD604 can be cascaded to provide greater levels of gain range by bypassing the preamplifier of the second channel. However, in multiple channel systems, cascading the AD604 with other devices in the AD60x VGA family that do not include a preamplifier may provide a more efficient solution. The AD604 provides access to the output of the preamplifier, allowing for external filtering between the preamplifier and the differential attenuator stage.

Note that scale factors up to 40 dB/V are achievable with reduced accuracy for scales above 30 dB/V. The gain scales linearly in decibels with control voltages of 0.4 V to 2.4 V with the 20 dB/V scale. Below and above this gain control range, the gain begins to deviate from the ideal linear-in-dB control law. The gain control region below 0.1 V is not used for gain control. When the gain control voltage is <50 mV, the amplifier channel is powered down to 1.9 mA.

The AD604 is available in 24-lead SSOP, SOIC, and PDIP packages and is guaranteed for operation over the -40°C to $+85^{\circ}\text{C}$ temperature range.

TABLE OF CONTENTS

Features	1
Applications.....	1
Functional Block Diagram	1
General Description	1
Revision History	2
Specifications.....	3
Absolute Maximum Ratings.....	5
ESD Caution.....	5
Pin Configuration and Function Descriptions.....	6
Typical Performance Characteristics	7
Theory of Operation	13
Preamplifier.....	14
Differential Ladder (Attenuator).....	15
AC Coupling	16
Gain Control Interface.....	16
Active Feedback Amplifier (Fixed-Gain Amp).....	16

REVISION HISTORY

12/10—Rev. F to Rev. G

Changes to Figure 1.....	1
Changes to Evaluation Board Section, Figure 55, Using the Preamplifier Section, Figure 56, and DSX Input Connections Section.....	24
Changes to Preamplifier Gain Section, Outputs Section, DC Operating Conditions Section, Table 4 and Table 5.....	25
Added Figure 57; Renumbered Sequentially	25
Changes to Figure 58 to Figure 61.....	26
Added Figure 62.....	26
Changes to Figure 63.....	27
Updated Outline Dimensions	28

4/10—Rev. E to Rev. F

Changes to Figure 55, DSX Input Connections Section, and Differential DSX Inputs Section	24
Changes to Figure 61, Deleted Table 6.....	27
Changes to Ordering Guide	29

10/08—Rev. D to Rev. E

Changes to Figure 1.....	1
Changes to Figure 37.....	13
Changes to Figure 41.....	15
Changes to Evaluation Board Model Name	24
Changes to Ordering Guide	29

1/08—Rev. C to Rev. D

Changes to AC Coupling Section.....	16
Changes to Applications Information Section.....	18

Applications Information	18
Ultralow Noise AGC Amplifier with 82 dB to 96 dB Gain Range.....	19
Ultralow Noise, Differential Input-Differential Output VGA	21
Medical Ultrasound TGC Driving the AD9050, a 10-Bit, 40 MSPS ADC.....	22
Evaluation Board.....	24
Connecting a Waveform to the AD604-EVALZ.....	24
DSX Input Connections	24
Preamplifier Gain	25
Outputs	25
DC Operating Conditions.....	25
Evaluation Board Artwork and Schematic	26
Outline Dimensions	28
Ordering Guide	29

Changes to An Ultralow Noise AGC Amplifier with 82 dB to 96 dB Gain Range Section.....	19
Changes to Figure 55 and Figure 56.....	24
Changes to Cascaded DSX Section and Outputs Section.....	25
Changes to Figure 57 to Figure 60.....	26
Changes to Figure 61 and Table 6.....	27
Changes to Ordering Guide	29

3/07—Rev. B to Rev. C

Added Evaluation Board Section	24
Added Evaluation Board Artwork and Schematics Section	26
Changes to Ordering Guide	29

12/06—Rev. A to Rev. B

Changes to General Description	1
Changes to Figure 54.....	23
Changes to Ordering Guide	25

1/04—Rev. 0 to Rev. A

Changes to Specifications.....	2
Changes to Absolute Maximum Ratings.....	3
Changes to Ordering Guide	3
Changes to Figure 1 Caption.....	5
Changes to Figure 11 Caption	6
Changes to Figure 17.....	6
Changes to Figure 51.....	17
Updated Outline Dimensions	18

10/96—Revision 0: Initial Version

SPECIFICATIONS

Each amplifier channel at $T_A = 25^\circ\text{C}$, $V_S = \pm 5\text{ V}$, $R_S = 50\ \Omega$, $R_L = 500\ \Omega$, $C_L = 5\text{ pF}$, $V_{\text{REF}} = 2.50\text{ V}$ (scaling = 20 dB/V), 0 dB to 48 dB gain range (preamplifier gain = 14 dB), $\text{VOCM} = 2.5\text{ V}$, C_1 and $C_2 = 0.1\ \mu\text{F}$ (see Figure 37), unless otherwise noted.

Table 1.

Parameter	Conditions	Min	Typ	Max	Unit
INPUT CHARACTERISTICS					
Preamplifier					
Input Resistance			300		k Ω
Input Capacitance			8.5		pF
Input Bias Current			-27		mA
Peak Input Voltage	Preamplifier gain = 14 dB		± 400		mV
	Preamplifier gain = 20 dB		± 200		mV
Input Voltage Noise	VGN = 2.9 V, $R_S = 0\ \Omega$				
	Preamplifier gain = 14 dB		0.8		nV/ $\sqrt{\text{Hz}}$
	Preamplifier gain = 20 dB		0.73		nV/ $\sqrt{\text{Hz}}$
Input Current Noise	Independent of gain		3.0		pA/ $\sqrt{\text{Hz}}$
Noise Figure	$R_S = 50\ \Omega$, $f = 10\text{ MHz}$, VGN = 2.9 V		2.3		dB
	$R_S = 200\ \Omega$, $f = 10\text{ MHz}$, VGN = 2.9 V		1.1		dB
DSX					
Input Resistance			175		Ω
Input Capacitance			3.0		pF
Peak Input Voltage			2.5 ± 2		V
Input Voltage Noise	VGN = 2.9 V		1.8		nV/ $\sqrt{\text{Hz}}$
Input Current Noise	VGN = 2.9 V		2.7		pA/ $\sqrt{\text{Hz}}$
Noise Figure	$R_S = 50\ \Omega$, $f = 10\text{ MHz}$, VGN = 2.9 V		8.4		dB
	$R_S = 200\ \Omega$, $f = 10\text{ MHz}$, VGN = 2.9 V		12		dB
Common-Mode Rejection Ratio	$f = 1\text{ MHz}$, VGN = 2.65 V		-20		dB
OUTPUT CHARACTERISTICS					
-3 dB Bandwidth	Constant with gain		40		MHz
Slew Rate	VGN = 1.5 V, output = 1 V step		170		V/ μs
Output Signal Range	$R_L \geq 500\ \Omega$		2.5 ± 1.5		V
Output Impedance	$f = 10\text{ MHz}$		2		Ω
Output Short-Circuit Current			± 40		mA
Harmonic Distortion					
HD2	VGN = 1 V, $V_{\text{OUT}} = 1\text{ V p-p}$ $f = 1\text{ MHz}$		-54		dBc
HD3	$f = 1\text{ MHz}$		-67		dBc
HD2	$f = 10\text{ MHz}$		-43		dBc
HD3	$f = 10\text{ MHz}$		-48		dBc
Two-Tone Intermodulation Distortion (IMD)	VGN = 2.9 V, $V_{\text{OUT}} = 1\text{ V p-p}$ $f = 1\text{ MHz}$		-74		dBc
	$f = 10\text{ MHz}$		-71		dBc
Third-Order Intercept	$f = 10\text{ MHz}$, VGN = 2.65 V, $V_{\text{OUT}} = 1\text{ V p-p}$, input referred		-12.5		dBm
1 dB Compression Point	$f = 1\text{ MHz}$, VGN = 2.9 V, output referred		15		dBm
Channel-to-Channel Crosstalk	$V_{\text{OUT}} = 1\text{ V p-p}$, $f = 1\text{ MHz}$, Channel 1: VGN = 2.65 V, inputs shorted, Channel 2: VGN = 1.5 V (mid gain)		-30		dB
Group Delay Variation	$1\text{ MHz} < f < 10\text{ MHz}$, full gain range		± 2		ns
VOCM Input Resistance			45		k Ω

AD604

Parameter	Conditions	Min	Typ	Max	Unit
ACCURACY					
Absolute Gain Error					
0 dB to 3 dB	0.25 V < VGN < 0.400 V	-1.2	+0.75	+3	dB
3 dB to 43 dB	0.400 V < VGN < 2.400 V	-1.0	±0.3	+1.0	dB
43 dB to 48 dB	2.400 V < VGN < 2.65 V	-3.5	-1.25	+1.2	dB
Gain Scaling Error	0.400 V < VGN < 2.400 V		±0.25		dB/V
Output Offset Voltage	VREF = 2.500 V, VOCM = 2.500 V	-50	±30	+50	mV
Output Offset Variation	VREF = 2.500 V, VOCM = 2.500 V		30	50	mV
GAIN CONTROL INTERFACE					
Gain Scaling Factor	VREF = 2.5 V, 0.4 V < VGN < 2.4 V	19	20	21	dB/V
	VREF = 1.67 V		30		dB/V
Gain Range	Preamplifier gain = 14 dB		0 to 48		dB
	Preamplifier gain = 20 dB		6 to 54		dB
Input Voltage (VGN) Range	20 dB/V, VREF = 2.5 V		0.1 to 2.9		V
Input Bias Current			-0.4		μA
Input Resistance			2		MΩ
Response Time	48 dB gain change		0.2		μs
VREF Input Resistance			10		kΩ
POWER SUPPLY					
Specified Operating Range	One complete channel		±5		V
	One DSX only		5		V
Power Dissipation	One complete channel		220		mW
	One DSX only		95		mW
Quiescent Supply Current	VPOS, one complete channel		32	36	mA
	VPOS, one DSX only		19	23	mA
	VNEG, one preamplifier only	-15	-12		mA
Powered Down	VPOS, VGN < 50 mV, one channel		1.9	3.0	mA
	VNEG, VGN < 50 mV, one channel		-150		μA
Power-Up Response Time	48 dB gain change, V _{OUT} = 2 V p-p		0.6		μs
Power-Down Response Time			0.4		μs

ABSOLUTE MAXIMUM RATINGS

Table 2.

Parameter ^{1, 2}	Rating
Supply Voltage $\pm V_S$ Pin 17 to Pin 20 (with Pin 16, Pin 22 = 0 V)	± 6.5 V
Input Voltages Pin 1, Pin 2, Pin 11, Pin 12	VPOS/2 ± 2 V continuous
Pin 4, Pin 9	± 2 V
Pin 5, Pin 8	VPOS, VNEG
Pin 6, Pin 7, Pin 13, Pin 14, Pin 23, Pin 24	VPOS, 0 V
Internal Power Dissipation	
PDIP (N)	2.2 W
SOIC (RW)	1.7 W
SSOP (RS)	1.1 W
Operating Temperature Range	-40°C to $+85^{\circ}\text{C}$
Storage Temperature Range	-65°C to $+150^{\circ}\text{C}$
Lead Temperature, Soldering 60 sec	300°C
θ_{JA} ³	
AD604AN	$105^{\circ}\text{C}/\text{W}$
AD604AR	$73^{\circ}\text{C}/\text{W}$
AD604ARS	$112^{\circ}\text{C}/\text{W}$
θ_{JC} ³	
AD604AN	$35^{\circ}\text{C}/\text{W}$
AD604AR	$38^{\circ}\text{C}/\text{W}$
AD604ARS	$34^{\circ}\text{C}/\text{W}$

¹ Pin 1, Pin 2, Pin 11 to Pin 14, Pin 23, and Pin 24 are part of a single-supply circuit. The part is likely to suffer damage if any of these pins are accidentally connected to VN.

² When driven from an external low impedance source.

³ Using MIL-STD-883 test method G43-87 with a 1S (2-layer) test board.

Stresses above those listed under Absolute Maximum Ratings may cause permanent damage to the device. This is a stress rating only; functional operation of the device at these or any other conditions above those indicated in the operational section of this specification is not implied. Exposure to absolute maximum rating conditions for extended periods may affect device reliability.

ESD CAUTION



ESD (electrostatic discharge) sensitive device. Charged devices and circuit boards can discharge without detection. Although this product features patented or proprietary protection circuitry, damage may occur on devices subjected to high energy ESD. Therefore, proper ESD precautions should be taken to avoid performance degradation or loss of functionality.

PIN CONFIGURATION AND FUNCTION DESCRIPTIONS

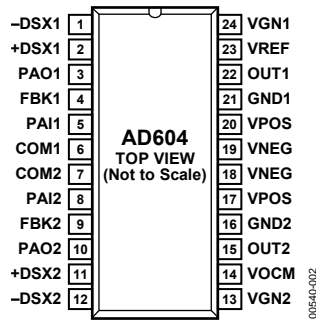

Figure 2. Pin Configuration

Table 3. Pin Function Descriptions

Pin No.	Mnemonic	Description
1	-DSX1	Channel 1 Negative Signal Input to DSX1.
2	+DSX1	Channel 1 Positive Signal Input to DSX1.
3	PAO1	Channel 1 Preamplifier Output.
4	FBK1	Channel 1 Preamplifier Feedback Pin.
5	PAI1	Channel 1 Preamplifier Positive Input.
6	COM1	Channel 1 Signal Ground. When this pin is connected to positive supply, Preamplifier 1 shuts down.
7	COM2	Channel 2 Signal Ground. When this pin is connected to positive supply, Preamplifier 2 shuts down.
8	PAI2	Channel 2 Preamplifier Positive Input.
9	FBK2	Channel 2 Preamplifier Feedback Pin.
10	PAO2	Channel 2 Preamplifier Output.
11	+DSX2	Channel 2 Positive Signal Input to DSX2.
12	-DSX2	Channel 2 Negative Signal Input to DSX2.
13	VGN2	Channel 2 Gain Control Input and Power-Down Pin. If this pin is grounded, the device is off; otherwise, positive voltage increases gain.
14	VOCM	Input to this pin defines the common mode of the output at OUT1 and OUT2.
15	OUT2	Channel 2 Signal Output.
16	GND2	Ground.
17	VPOS	Positive Supply.
18	VNEG	Negative Supply.
19	VNEG	Negative Supply.
20	VPOS	Positive Supply.
21	GND1	Ground.
22	OUT1	Channel 1 Signal Output.
23	VREF	Input to this pin sets gain scaling for both channels to 2.5 V = 20 dB/V and 1.67 V = 30 dB/V.
24	VGN1	Channel 1 Gain Control Input and Power-Down Pin. If this pin is grounded, the device is off; otherwise, positive voltage increases gain.

TYPICAL PERFORMANCE CHARACTERISTICS

Unless otherwise noted, G (preamplifier) = 14 dB, VREF = 2.5 V (20 dB/V scaling), f = 1 MHz, RL = 500 Ω, CL = 5 pF, TA = 25°C, and VSS = ±5 V.

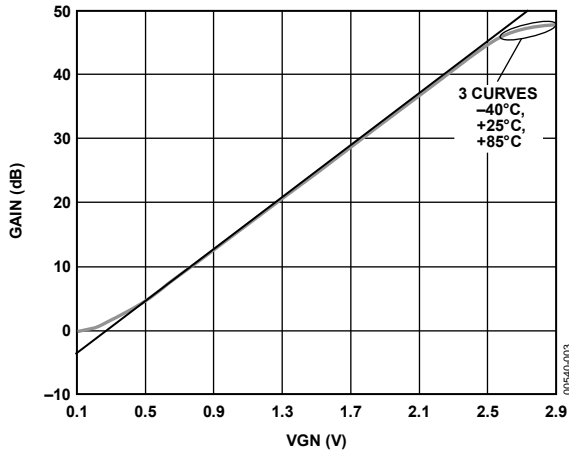

Figure 3. Gain vs. VGN for Three Temperatures

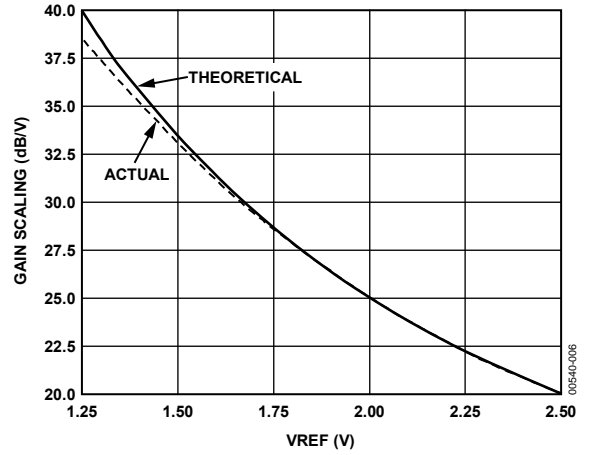

Figure 6. Gain Scaling vs. VREF

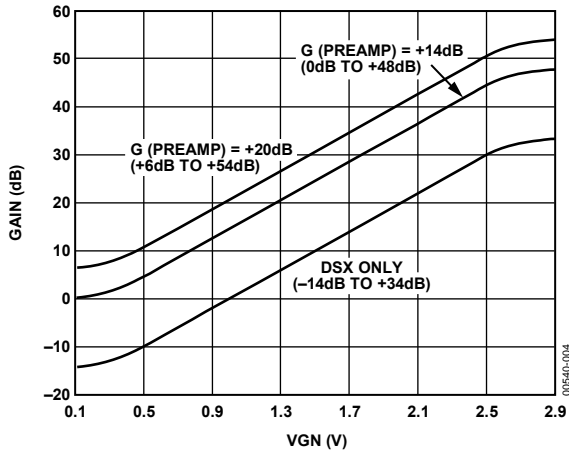

Figure 4. Gain vs. VGN for Different Preamplifier Gains

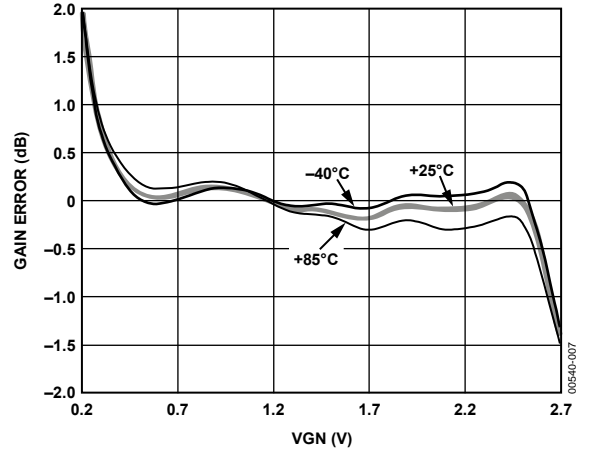

Figure 7. Gain Error vs. VGN

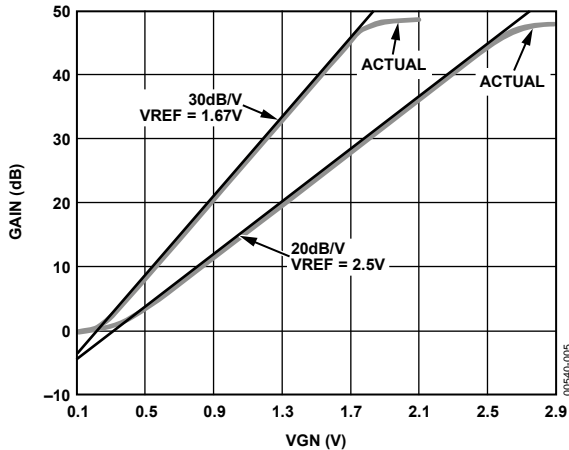

Figure 5. Gain vs. VGN for Different Gain Scalings

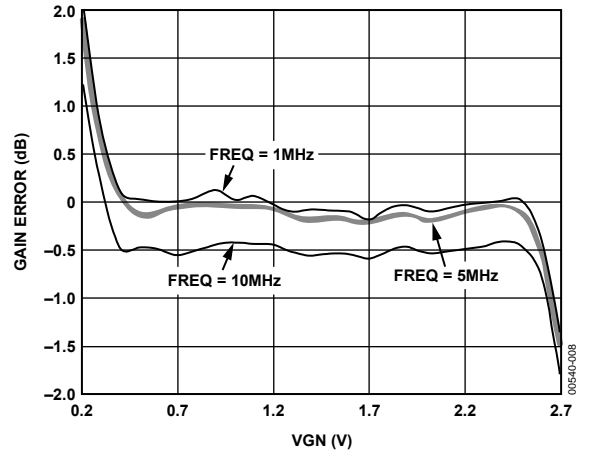

Figure 8. Gain Error vs. VGN at Different Frequencies

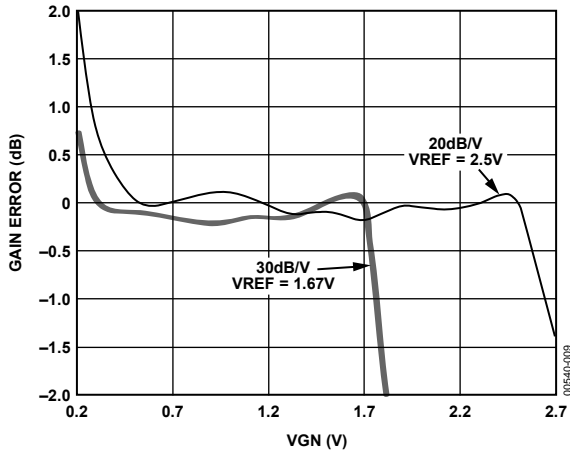

Figure 9. Gain Error vs. VGN for Two Gain Scaling Values

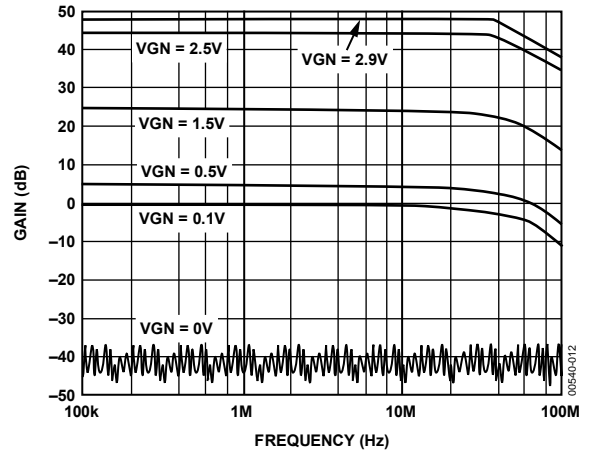

Figure 12. AC Response for Various Values of VGN

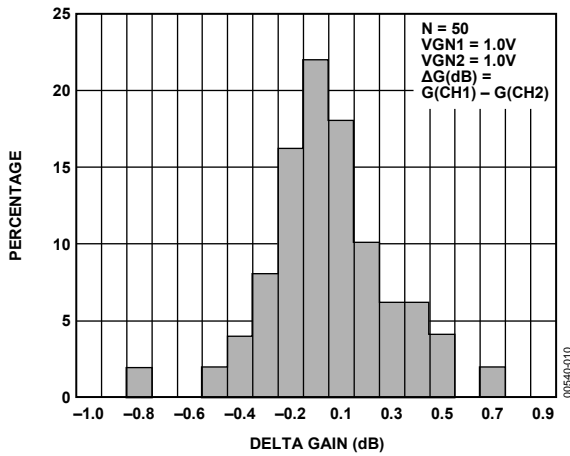

Figure 10. Gain Match; VGN1 = VGN2 = 1.0V

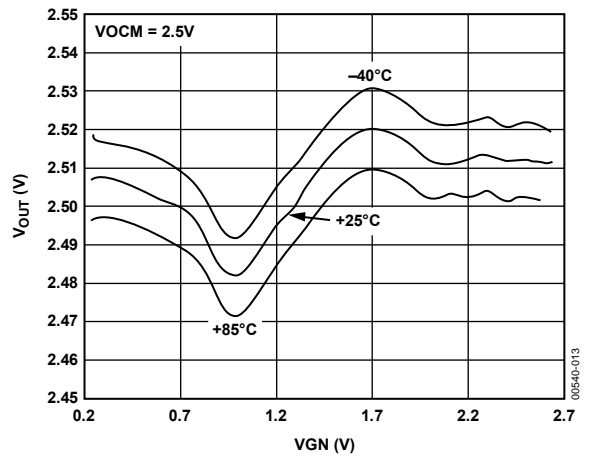

Figure 13. Output Offset vs. VGN for Three Temperatures

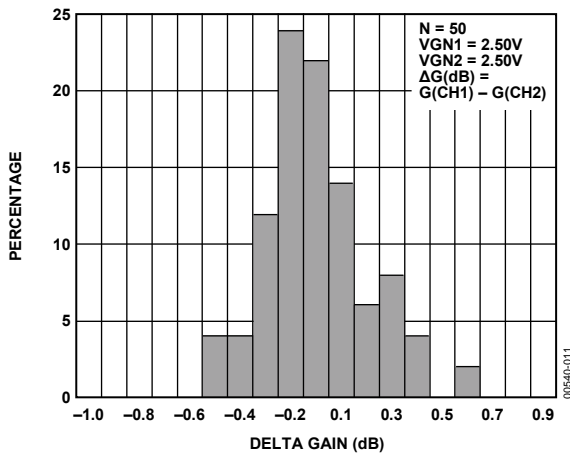

Figure 11. Gain Match; VGN1 = VGN2 = 2.50V

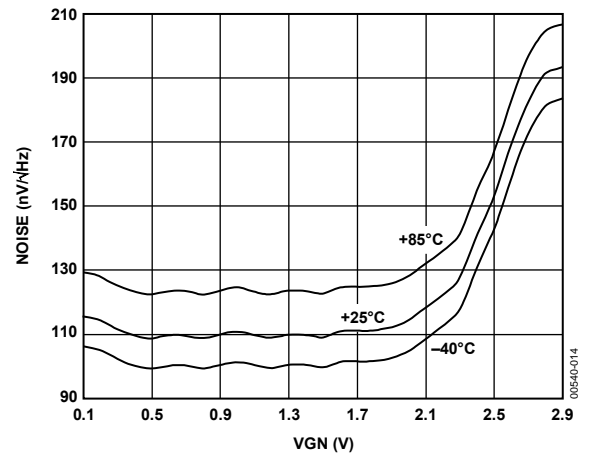

Figure 14. Output Referred Noise vs. VGN for Three Temperatures

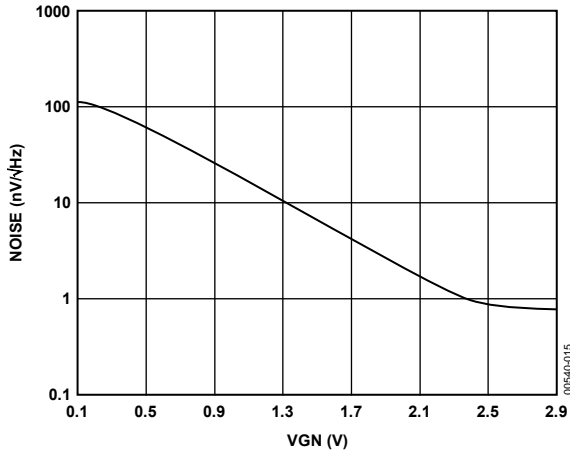

Figure 15. Input Referred Noise vs. VGN

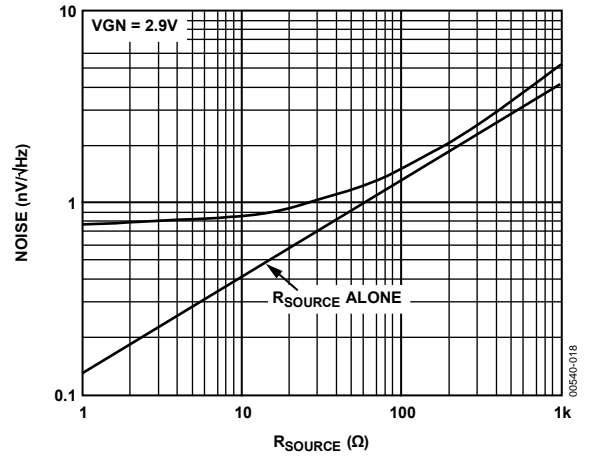

Figure 18. Input Referred Noise vs. R_{SOURCE}

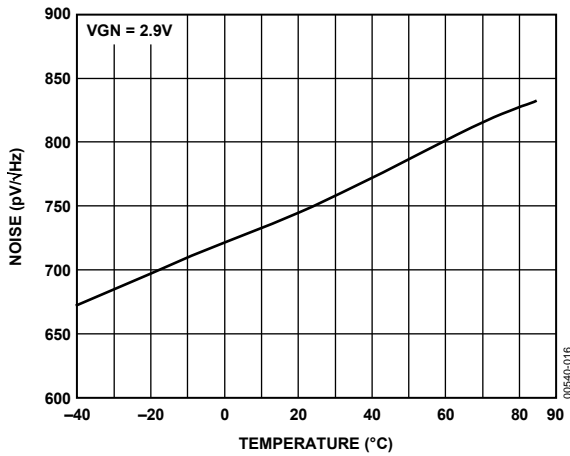

Figure 16. Input Referred Noise vs. Temperature

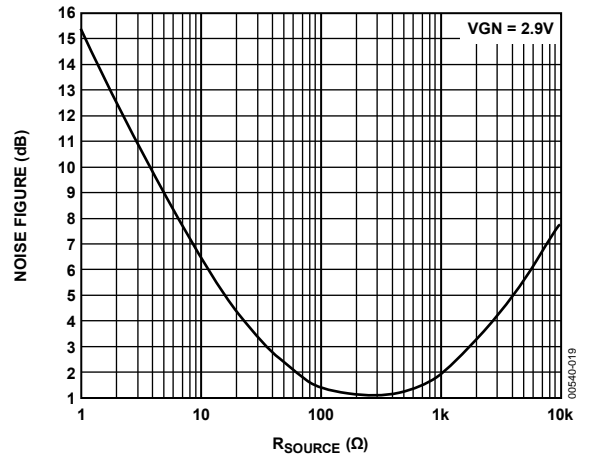

Figure 19. Noise Figure vs. R_{SOURCE}

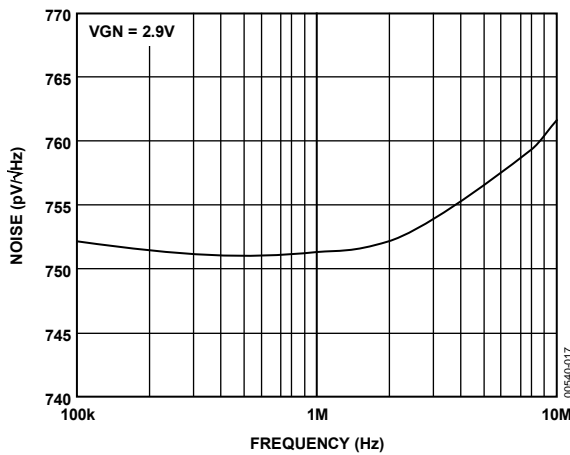

Figure 17. Input Referred Noise vs. Frequency

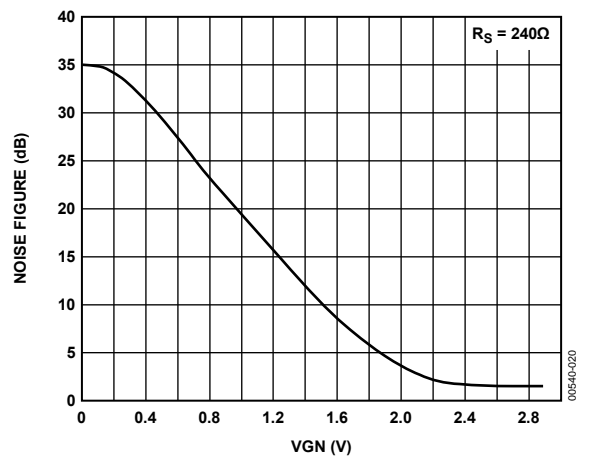

Figure 20. Noise Figure vs. VGN

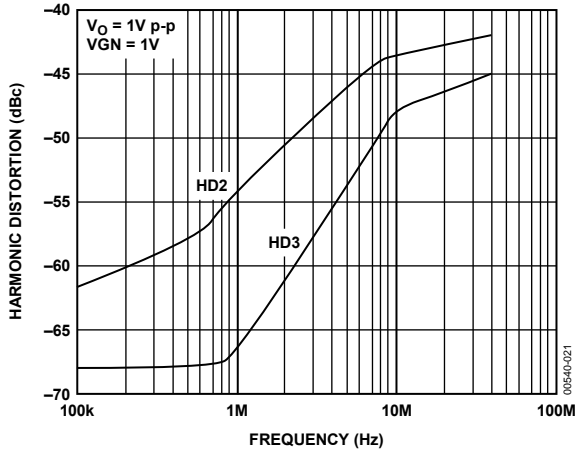

Figure 21. Harmonic Distortion vs. Frequency

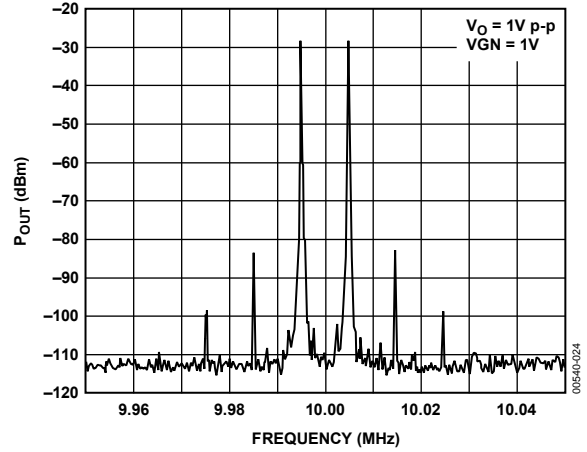

Figure 24. Intermodulation Distortion

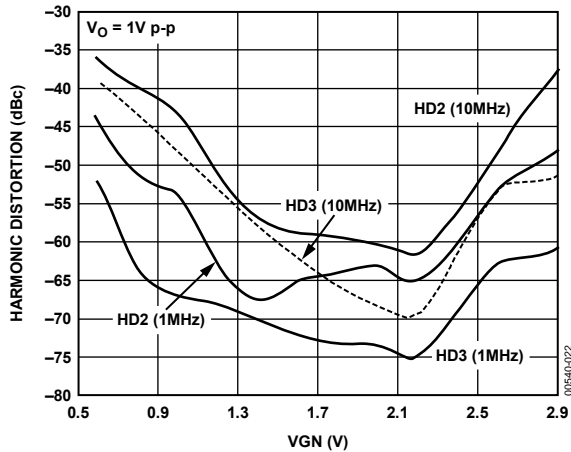

Figure 22. Harmonic Distortion vs. VGN

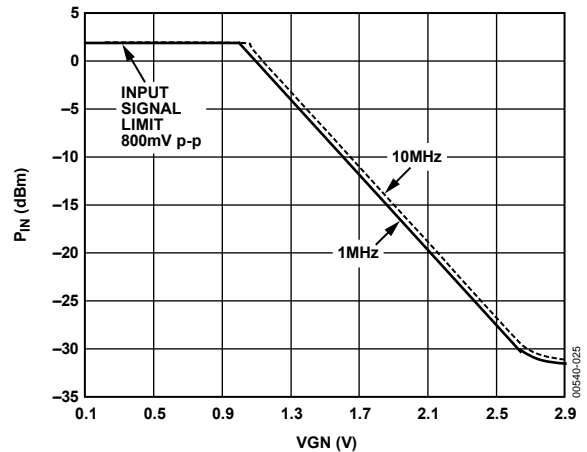

Figure 25. 1 dB Compression vs. VGN

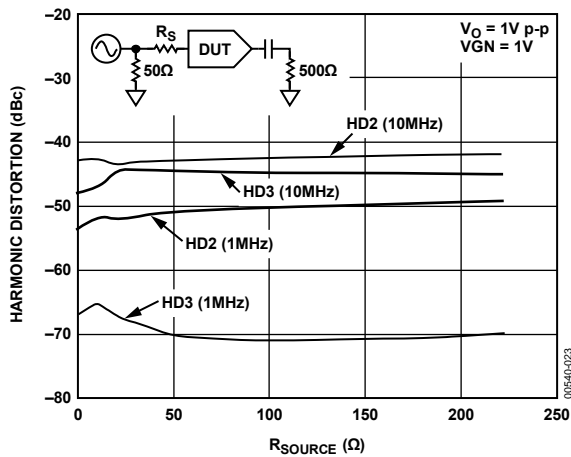

Figure 23. Harmonic Distortion vs. R_{SOURCE}

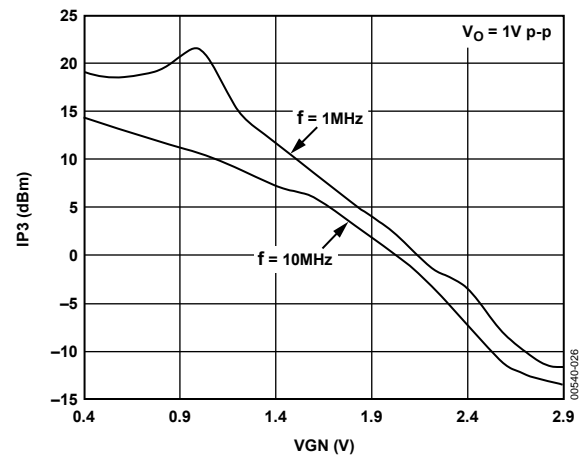

Figure 26. Third-Order Intercept vs. VGN

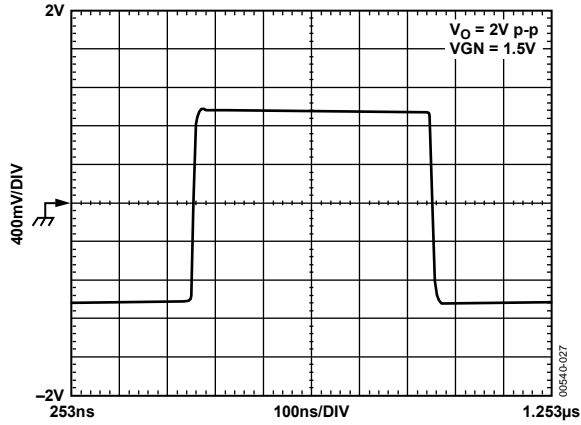

Figure 27. Large Signal Pulse Response

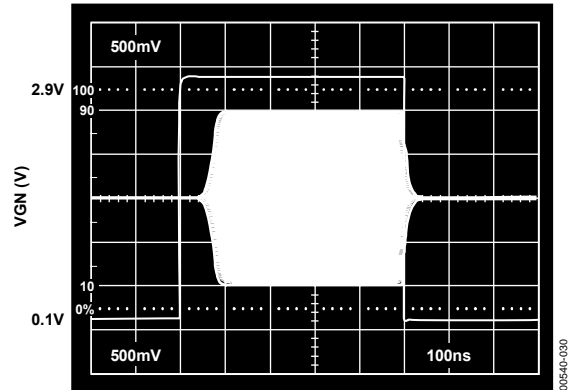

Figure 30. Gain Response

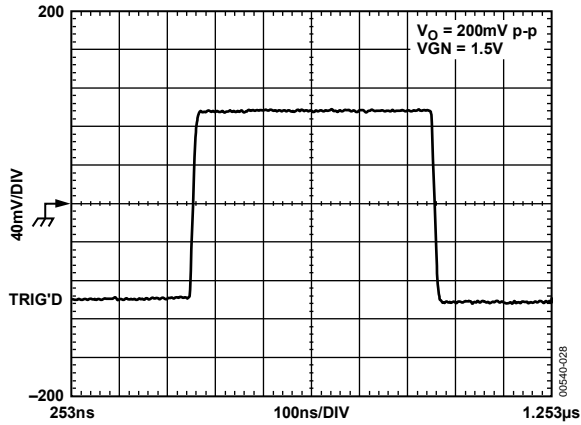

Figure 28. Small Signal Pulse Response

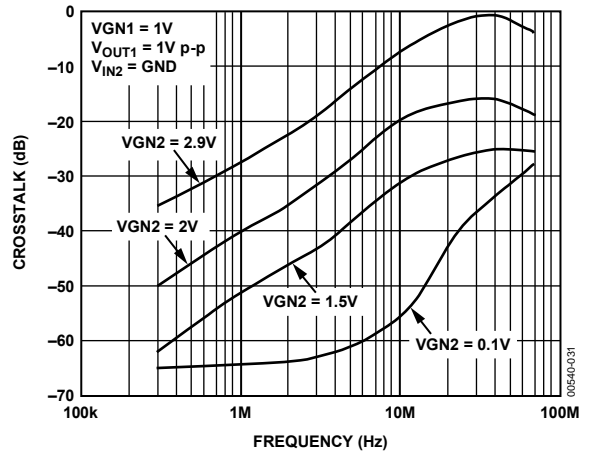

Figure 31. Crosstalk (Channel 1 to Channel 2) vs. Frequency

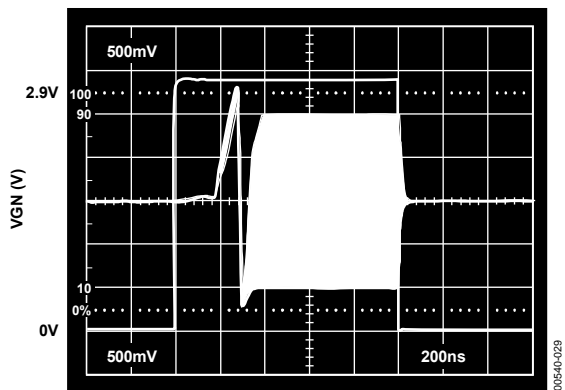

Figure 29. Power-Up/Power-Down Response

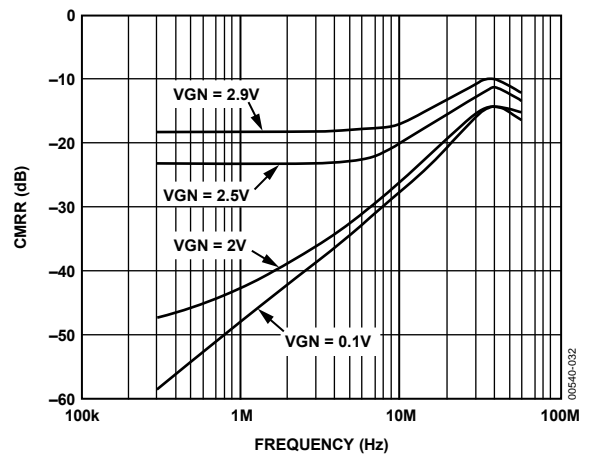

Figure 32. DSX Common-Mode Rejection Ratio vs. Frequency

AD604

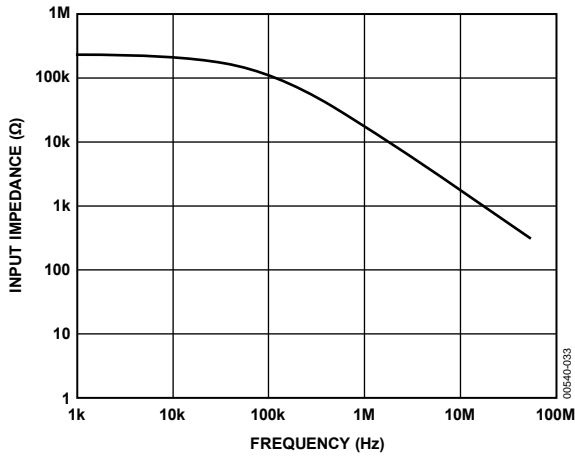

Figure 33. Input Impedance vs. Frequency

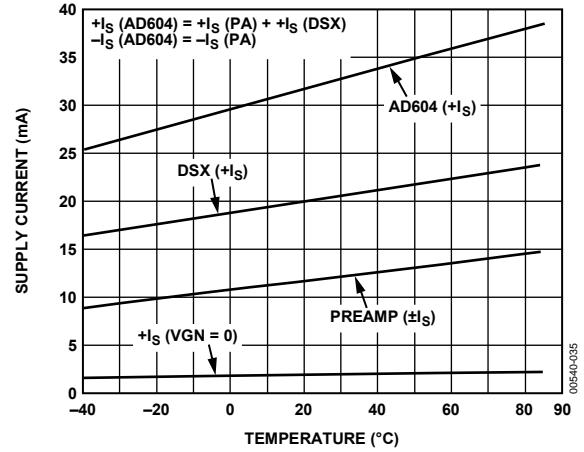

Figure 35. Supply Current (One Channel) vs. Temperature

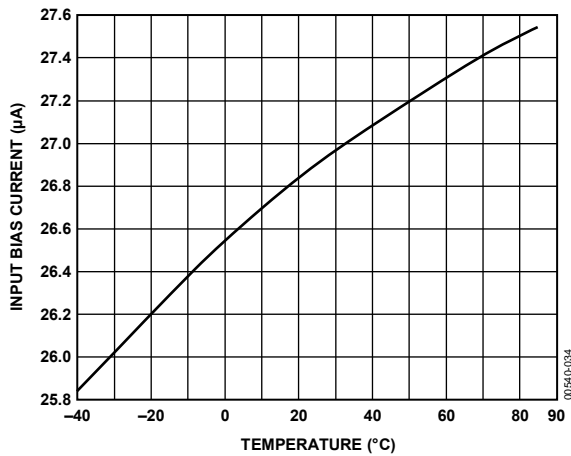

Figure 34. Input Bias Current vs. Temperature

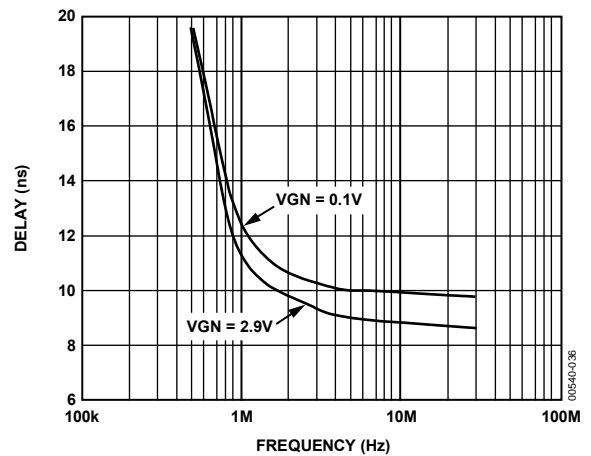

Figure 36. Group Delay vs. Frequency

THEORY OF OPERATION

The AD604 is a dual-channel VGA with an ultralow noise preamplifier. Figure 37 shows the simplified block diagram of one channel. Each identical channel consists of a preamplifier with gain setting resistors (R5, R6, and R7) and a single-supply X-AMP® (hereafter called DSX, differential single-supply X-AMP) made up of the following:

- A precision passive attenuator (differential ladder).
- A gain control block.
- A VOCM buffer with supply splitting resistors (R3 and R4).
- An active feedback amplifier (AFA) with gain setting resistors (R1 and R2). To understand the active-feedback amplifier topology, refer to the [AD830](#) data sheet. The AD830 is a practical implementation of the idea.

The preamplifier is powered by a ± 5 V supply, while the DSX uses a single +5 V supply. The linear-in-dB gain response of the AD604 can generally be described by

$$G \text{ (dB)} = \text{Gain Scaling (dB/V)} \times \text{Gain Control (V)} + (\text{Preamp Gain (dB)} - 19 \text{ dB}) \quad (1)$$

Each channel provides between 0 dB to 48.4 dB and 6 dB to 54.4 dB of gain, depending on the user-determined preamplifier gain. The center 40 dB of gain is exactly linear-in-dB while the gain error increases at the top and bottom of the range. The gain of the preamplifier is typically either 14 dB or 20 dB but can be set to intermediate values by a single external resistor (see the Preamplifier section for details). The gain of the DSX can vary from -14 dB to $+34.4$ dB, as determined by the gain control voltage (VGN). The VREF input establishes the gain scaling;

the useful gain scaling range is between 20 dB/V and 40 dB/V for a VREF voltage of 2.5 V and 1.25 V, respectively. For

example, if the preamp gain is set to 14 dB and VREF is set to 2.50 V (to establish a gain scaling of 20 dB/V), the gain equation simplifies to

$$G \text{ (dB)} = 20 \text{ (dB/V)} \times \text{VGN (V)} - 5 \text{ dB}$$

The desired gain can then be achieved by setting the unipolar gain control (VGN) to a voltage within its nominal operating range of 0.25 V to 2.65 V (for 20 dB/V gain scaling). The gain is monotonic for a complete gain control voltage range of 0.1 V to 2.9 V. Maximum gain can be achieved at a VGN of 2.9 V.

The inputs VREF and VOCM are common to both channels. They are decoupled to ground, minimizing interchannel crosstalk. For the highest gain scaling accuracy, VREF should have an external low impedance voltage source. For low accuracy 20 dB/V applications, the VREF input can be decoupled with a capacitor to ground. In this mode, the gain scaling is determined by the midpoint between VPOS and GND; therefore, care should be taken to control the supply voltage to 5 V. The input resistance looking into the VREF pin is $10 \text{ k}\Omega \pm 20\%$.

The DSX portion of the AD604 is a single-supply circuit, and the VOCM pin is used to establish the dc level of the midpoint of this portion of the circuit. The VOCM pin only needs an external decoupling capacitor to ground to center the midpoint between the supply voltages (5 V, GND); however, the VOCM can be adjusted to other voltage levels if the dc common-mode level of the output is important to the user (for example, see the section entitled Medical Ultrasound TGC Driving the AD9050, a 10-Bit, 40 MSPS ADC). The input resistance looking into the VOCM pin is $45 \text{ k}\Omega \pm 20\%$.

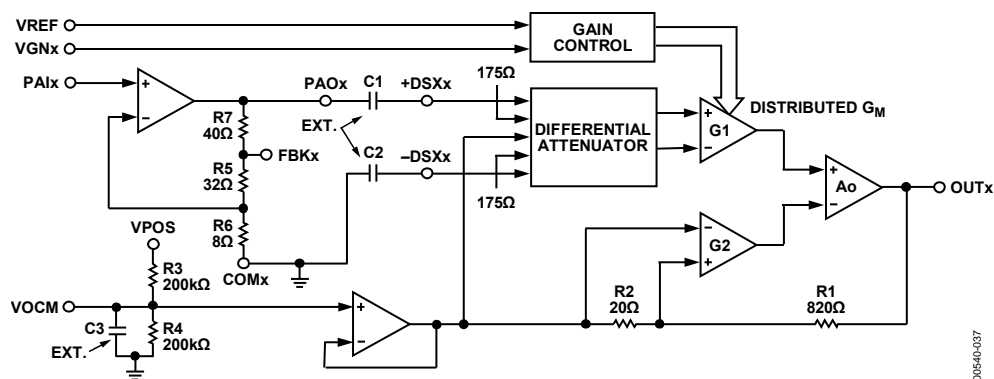

Figure 37. Simplified Block Diagram of a Single Channel of the AD604

PREAMPLIFIER

The input capability of the following single-supply DSX (2.5 ± 2 V for a +5 V supply) limits the maximum input voltage of the preamplifier to ± 400 mV for the 14 dB gain configuration or ± 200 mV for the 20 dB gain configuration.

The preamplifier gain can be programmed to 14 dB or 20 dB by either shorting the FBK1 node to PAO1 (14 dB) or by leaving the FBK1 node open (20 dB). These two gain settings are very accurate because they are set by the ratio of the on-chip resistors. Any intermediate gain can be achieved by connecting the appropriate resistor value between PAO1 and FBK1 according to Equation 2 and Equation 3.

$$G = \frac{V_{OUT}}{V_{IN}} = \frac{(R7 \parallel R_{EXT}) + R5 + R6}{R6} \quad (2)$$

$$R_{EXT} = \frac{[R6 \times G - (R5 + R6)] \times R7}{R7 - (R6 \times G) + (R5 + R6)} \quad (3)$$

Because the internal resistors have an absolute tolerance of $\pm 20\%$, the gain can be in error by as much as 0.33 dB when R_{EXT} is 30 Ω , where it is assumed that R_{EXT} is exact.

Figure 38 shows how the preamplifier is set to gains of 14 dB, 17.5 dB, and 20 dB. The gain range of a single channel of the AD604 is 0 dB to 48 dB when the preamplifier is set to 14 dB (Figure 38a), 3.5 dB to 51.5 dB for a preamp gain of 17.5 dB (Figure 38b), and 6 dB to 54 dB for the highest preamp gain of 20 dB (Figure 38c).

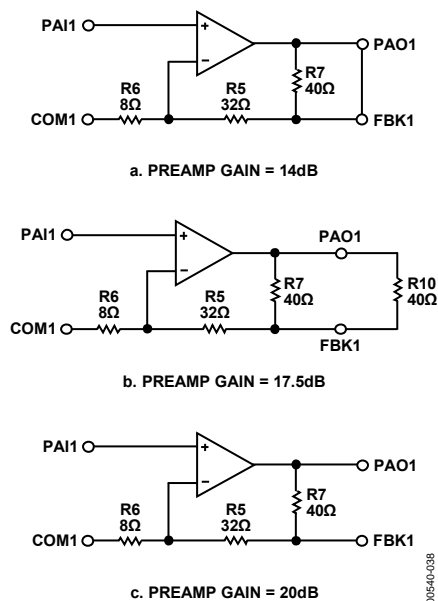

Figure 38. Preamplifier Gain Programmability

For a preamplifier gain of 14 dB, the -3 dB small signal bandwidth of the preamplifier is 130 MHz. When the gain is at its maximum of 20 dB, the bandwidth is reduced by half to 65 MHz. Figure 39 shows the ac response for the three preamp gains shown in Figure 38. Note that the gain for an R_{EXT} of 40 Ω should be 17.5 dB, but the mismatch between the internal resistors and the external resistor causes the actual gain for this particular

preamplifier to be 17.7 dB. The -3 dB small signal bandwidth of one complete channel of the AD604 (preamplifier and DSX) is 40 MHz and is independent of gain.

To achieve optimum specifications, power and ground management are critical to the AD604. Large dynamic currents result because of the low resistances needed for the desired noise performance. Most of the difficulty is with the very low gain setting resistors of the preamplifier that allow for a total input referred noise, including the DSX, as low as 0.8 nV/ $\sqrt{\text{Hz}}$. The consequently large dynamic currents have to be carefully handled to maintain performance even at large signal levels.

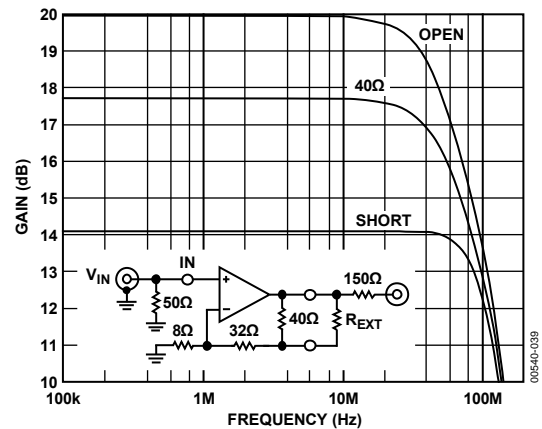

Figure 39. AC Response for Preamplifier Gains of 14 dB, 17.5 dB, and 20 dB

The preamplifier uses a dual ± 5 V supply to accommodate large dynamic currents and a ground referenced input. The preamplifier output is also ground referenced and requires a common-mode level shift into the single-supply DSX. The two external coupling capacitors (C1 and C2 in Figure 37) connected to the PAO1 and +DSXx, and -DSXx, nodes and ground, respectively, perform this function (see the AC Coupling section). In addition, they eliminate any offset that would otherwise be introduced by the preamplifier. It should be noted that an offset of 1 mV at the input of the DSX is amplified by 34.4 dB ($\times 52.5$) when the gain control voltage is at its maximum; this equates to 52.5 mV at the output. AC coupling is consequently required to keep the offset from degrading the output signal range.

The gain-setting preamplifier feedback resistors are small enough (8 Ω and 32 Ω) that even an additional 1 Ω in the ground connection at Pin COM1 (the input common-mode reference) seriously degrades gain accuracy and noise performance. This node is sensitive, and careful attention is necessary to minimize the ground impedance. All connections to the COM1 node should be as short as possible.

The preamplifier, including the gain setting resistors, has a noise performance of 0.71 nV/ $\sqrt{\text{Hz}}$ and 3 pA/ $\sqrt{\text{Hz}}$. Note that a significant portion of the total input referred voltage noise is due to the feedback resistors. The equivalent noise resistance presented by R5 and R6 in parallel is nominally 6.4 Ω , which contributes 0.33 nV/ $\sqrt{\text{Hz}}$ to the total input referred voltage noise.

The larger portion of the input referred voltage noise comes from the amplifier with $0.63 \text{ nV}/\sqrt{\text{Hz}}$. The current noise is independent of gain and depends only on the bias current in the input stage of the preamplifier, which is $3 \text{ pA}/\sqrt{\text{Hz}}$.

The preamplifier can drive $40 \text{ }\Omega$ (the nominal feedback resistors) and the following $175 \text{ }\Omega$ ladder load of the DSX with low distortion. For example, at 10 MHz and 1 V at the output, the preamplifier has less than -45 dB of second and third harmonic distortion when driven from a low ($25 \text{ }\Omega$) source resistance.

In applications that require more than 48 dB of gain range, two AD604 channels can be cascaded. Because the preamplifier has a limited input signal range and consumes over half (120 mW) of the total power (220 mW), and its ultralow noise is not necessary after the first AD604 channel, a shutdown mechanism that disables only the preamplifier is provided. To shut down the preamplifier, connect the COM1 pin and/or COM2 pin to the positive supply; the DSX is unaffected. For additional details, refer to the Applications Information section.

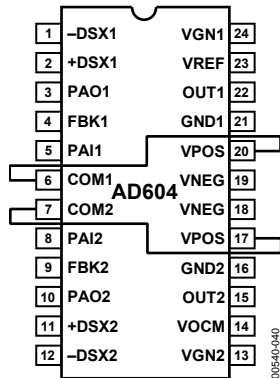

Figure 40. Shutdown of Preamplifiers Only

DIFFERENTIAL LADDER (ATTENUATOR)

The attenuator before the fixed-gain amplifier of the DSX is realized by a differential 7-stage R - $1.5R$ resistive ladder network with an untrimmed input resistance of $175 \text{ }\Omega$ single-ended or $350 \text{ }\Omega$ differential. The signal applied at the input of the ladder network is attenuated by 6.908 dB per tap; thus, the attenuation at the first tap is 0 dB , at the second, 13.816 dB , and so on, all the way to the last tap where the attenuation is 48.356 dB (see Figure 41).

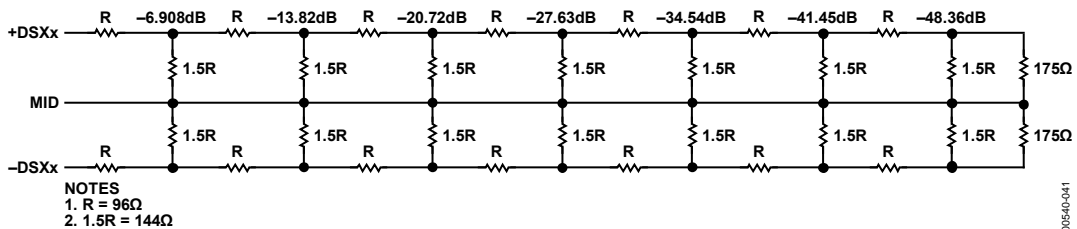

Figure 41. R - $1.5R$ Dual Ladder Network

A unique circuit technique is used to interpolate continuously among the tap points, thereby providing continuous attenuation from 0 dB to -48.36 dB . The ladder network, together with the interpolation mechanism, can be considered a voltage-controlled potentiometer.

Because the DSX circuit uses a single voltage power supply, the input biasing is provided by the VOCM buffer driving the MID node (see Figure 41). Without internal biasing, the user would have to dc bias the inputs externally. If not done carefully, the biasing network can introduce additional noise and offsets. By providing internal biasing, the user is relieved of this task and only needs to ac-couple the signal into the DSX. Note that the input to the DSX is still fully differential if driven differentially; that is, Pin $+DSXx$ and Pin $-DSXx$ see the same signal but with opposite polarity (see the Ultralow Noise, Differential Input-Differential Output VGA section).

What changes is the load seen by the driver; it is $175 \text{ }\Omega$ when each input is driven single-ended but $350 \text{ }\Omega$ when driven differentially. This is easily explained by thinking of the ladder network as two $175 \text{ }\Omega$ resistors connected back-to-back with the middle node, MID, being biased by the VOCM buffer. A differential signal applied between the $+DSXx$ and $-DSXx$ nodes results in zero current into the MID node, but a single-ended signal applied to either input, $+DSXx$ or $-DSXx$, while the other input is ac-grounded causes the current delivered by the source to flow into the VOCM buffer via the MID node.

The ladder resistor value of $175 \text{ }\Omega$ provides the optimum balance between the load driving capability of the preamplifier and the noise contribution of the resistors. An advantage of the X-AMP architecture is that the output referred noise is constant vs. gain over most of the gain range. Figure 41 shows that the tap resistance is equal for all taps after only a few taps away from the inputs. The resistance seen looking into each tap is $54.4 \text{ }\Omega$, which makes $0.95 \text{ nV}/\sqrt{\text{Hz}}$ of Johnson noise spectral density. Because there are two attenuators, the overall noise contribution of the ladder network is $\sqrt{2}$ times $0.95 \text{ nV}/\sqrt{\text{Hz}}$ or $1.34 \text{ nV}/\sqrt{\text{Hz}}$, a large fraction of the total DSX noise. The balance of the DSX circuit components contributes another $1.2 \text{ nV}/\sqrt{\text{Hz}}$, which together with the attenuator produces $1.8 \text{ nV}/\sqrt{\text{Hz}}$ of total DSX input referred noise.

AC COUPLING

The DSX portion of the AD604 is a single-supply circuit and, therefore, its inputs need to be ac-coupled to accommodate ground-based signals. External Capacitors C1 and C2 in Figure 37 level shift the ground referenced preamplifier output from ground to the dc value established by VOXM (nominal 2.5 V). C1 and C2, together with the 175 Ω looking into each of the DSX inputs (+DSXx and -DSXx), act as high-pass filters with corner frequencies depending on the values chosen for C1 and C2. As an example, for values of 0.1 μF at C1 and C2, combined with the 175 Ω input resistance at each side of the differential ladder of the DSX, the -3 dB high-pass corner is 9.1 kHz.

If the AD604 output needs to be ground referenced, another ac coupling capacitor is required for level shifting. This capacitor also eliminates any dc offsets contributed by the DSX. With a nominal load of 500 Ω and a 0.1 μF coupling capacitor, this adds a high-pass filter with -3 dB corner frequency at about 3.2 kHz.

The choice for all three of these coupling capacitors depends on the application. They should allow the signals of interest to pass unattenuated while, at the same time, they can be used to limit the low frequency noise in the system.

GAIN CONTROL INTERFACE

The gain control interface provides an input resistance of approximately 2 MΩ at VGN1 and gain scaling factors from 20 dB/V to 40 dB/V for VREF input voltages of 2.5 V to 1.25 V, respectively. The gain scales linearly in decibels for the center 40 dB of gain range, which for VGN is equal to 0.4 V to 2.4 V for the 20 dB/V scale and 0.2 V to 1.2 V for the 40 dB/V scale. Figure 42 shows the ideal gain curves for a nominal preamplifier gain of 14 dB, which are described by the following equations:

$$G (20 \text{ dB/V}) = 20 \times VGN - 5, VREF = 2.500 \text{ V} \quad (4)$$

$$G (20 \text{ dB/V}) = 30 \times VGN - 5, VREF = 1.666 \text{ V} \quad (5)$$

$$G (20 \text{ dB/V}) = 40 \times VGN - 5, VREF = 1.250 \text{ V} \quad (6)$$

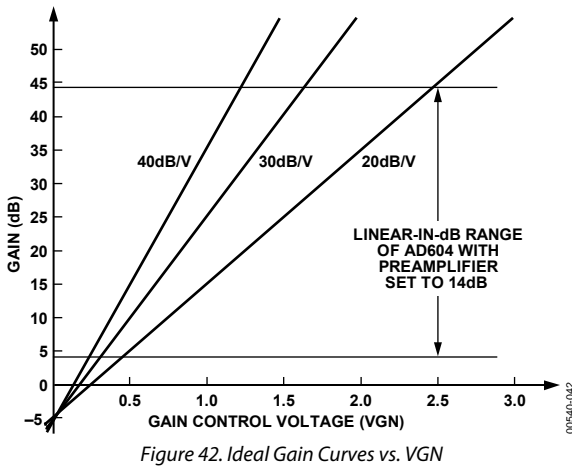

Figure 42. Ideal Gain Curves vs. VGN

From these equations, it can be seen that all gain curves intercept at the same -5 dB point; this intercept is +6 dB higher (+1 dB) if the preamplifier gain is set to +20 dB or +14 dB lower (-19 dB) if the preamplifier is not used at all. Outside the central linear range, the gain starts to deviate from the ideal control law but still provides another 8.4 dB of range. For a given gain scaling, VREF can be calculated as shown in Equation 7.

$$VREF = \frac{2.500 \text{ V} \times 20 \text{ dB/V}}{\text{Gain Scale}} \quad (7)$$

Usable gain control voltage ranges are 0.1 V to 2.9 V for the 20 dB/V scale and 0.1 V to 1.45 V for the 40 dB/V scale. VGN voltages of less than 0.1 V are not used for gain control because below 50 mV the channel (preamplifier and DSX) is powered down. This can be used to conserve power and, at the same time, to gate off the signal. The supply current for a powered-down channel is 1.9 mA; the response time to power the device on or off is less than 1 μs.

ACTIVE FEEDBACK AMPLIFIER (FIXED-GAIN AMP)

To achieve single-supply operation and a fully differential input to the DSX, an active feedback amplifier (AFA) is used. The AFA is an op amp with two gm stages; one of the active stages is used in the feedback path (therefore the name), while the other is used as a differential input. Note that the differential input is an open-loop gm stage that requires it to be highly linear over the expected input signal range. In this design, the gm stage that senses the voltages on the attenuator is a distributed one; for example, there are as many gm stages as there are taps on the ladder network. Only a few of them are on at any one time, depending on the gain control voltage.

The AFA makes a differential input structure possible because one of its inputs (G1) is fully differential; this input is made up of a distributed gm stage. The second input (G2) is used for feedback. The output of G1 is some function of the voltages sensed on the attenuator taps, which is applied to a high-gain amplifier (A0). Because of negative feedback, the differential input to the high-gain amplifier has to be zero; this in turn implies that the differential input voltage to G2 times gm2 (the transconductance of G2) has to be equal to the differential input voltage to G1 times gm1 (the transconductance of G1).

Therefore, the overall gain function of the AFA is

$$\frac{V_{OUT}}{V_{ATTEN}} = \frac{g_{m1}}{g_{m2}} \times \frac{R1 + R2}{R2} \quad (8)$$

where:

VOUT is the output voltage.

VATTEN is the effective voltage sensed on the attenuator.

$$(R1 + R2)/R2 = 42$$

$$g_{m1}/g_{m2} = 1.25$$

The overall gain is thus 52.5 (34.4 dB).

The AFA offers the following additional features:

- The ability to invert the signal by switching the positive and negative inputs to the ladder network
- The possibility of using DSX1 input as a second signal input
- Fully differential high-impedance inputs when both preamplifiers are used with one DSX (the other DSX could still be used alone)
- Independent control of the DSX common-mode voltage

Under normal operating conditions, it is best to connect a decoupling capacitor to VO_{CM}, in which case, the common-mode voltage of the DSX is half the supply voltage, which allows for maximum signal swing. Nevertheless, the common-mode voltage can be shifted up or down by directly applying a voltage to VO_{CM}. It can also be used as another signal input, the only limitation being the rather low slew rate of the VO_{CM} buffer.

If the dc level of the output signal is not critical, another coupling capacitor is normally used at the output of the DSX; again, this is done for level shifting and to eliminate any dc offsets contributed by the DSX (see the AC Coupling section).

APPLICATIONS INFORMATION

The basic circuit in Figure 43 shows the connections for one channel of the AD604. The signal is applied at Pin 5. RGN is normally 0, in which case the preamplifier is set to a gain of 5 (14 dB). When FBK1 is left open, the preamplifier is set to a gain of 10 (20 dB), and the gain range shifts up by 6 dB. The ac coupling capacitors before $-DSX1$ and $+DSX1$ should be selected according to the required lower cutoff frequency. In this example, the $0.1\ \mu\text{F}$ capacitors, together with the $175\ \Omega$ seen looking into each of the $DSXx$ input pins, provide a $-3\ \text{dB}$ high-pass corner of about 9.1 kHz. The upper cutoff frequency is determined by the bandwidth of the channel, which is 40 MHz. Note that the signal can be simply inverted by connecting the output of the preamplifier to $-DSX1$ instead of $+DSX1$; this is due to the fully differential input of the DSX.

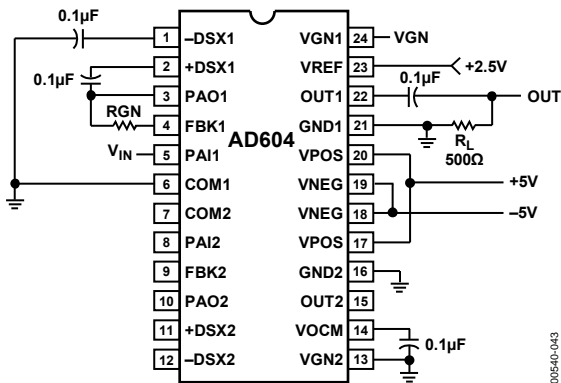

Figure 43. Basic Connections for a Single Channel

In Figure 43, the output is ac-coupled for optimum performance. For dc coupling, as shown in Figure 52, the capacitor can be eliminated if $VOCM$ is biased at the same 3.3 V common-mode voltage as the analog-to-digital converter, [AD9050](#).

$VREF$ requires a voltage of 1.25 V to 2.5 V, with between 40 dB/V and 20 dB/V gain scaling, respectively. Voltage VGN controls the gain; its nominal operating range is from 0.25 V to 2.65 V for 20 dB/V gain scaling and 0.125 V to 1.325 V for 40 dB/V scaling. When $VGNx$ is grounded, the channel powers down and disables its output.

$COM1$ is the main signal ground for the preamplifier and needs to be connected with as short a connection as possible to the input ground. Because the internal feedback resistors of the preamplifier are very small for noise reasons ($8\ \Omega$ and $32\ \Omega$ nominally), it is of utmost importance to keep the resistance in this connection to a minimum. Furthermore, excessive inductance in this connection can lead to oscillations.

Because of the ultralow noise and wide bandwidth of the AD604, large dynamic currents flow to and from the power supply. To ensure the stability of the part, careful attention to supply decoupling is required. A large storage capacitor in parallel with a smaller high-frequency capacitor connected at the supply pins, together with a ferrite bead coming from the supply, should be used to ensure high-frequency stability.

To provide for additional flexibility, $COM1$ can be used to disable the preamplifier. When $COM1$ is connected to VP , the preamplifier is off, yet the DSX portion can be used independently. This may be of value when cascading the two DSX stages in the AD604. In this case, the first DSX output signal with respect to noise is large and using the second preamplifier at this point would waste power (see Figure 44).

The 50 Ω termination resistor, in parallel with the 50 Ω source resistance of the signal generator, forms an effective resistance of 25 Ω as seen by the input of the preamplifier, creating 4.07 μV of rms noise at a bandwidth of 40 MHz. The noise floor of this channel is consequently 6.5 μV rms, the rms sum of these two main noise sources. The minimum detectable signal (MDS) for this circuit is +6.5 μV rms (−90.7 dBm). Generally, the measured signal should be about a factor of three larger than the noise floor, in this case 19.5 μV rms. Note that the 25 μV rms signal that this AGC circuit can correct for is just slightly above the MDS. Of course, the sensitivity of the input can be improved by band-limiting the signal; if the noise bandwidth is reduced by a factor of four to 10 MHz, the noise floor of the AGC circuit with a 50 Ω termination resistor drops to +3.25 μV rms (−96.7 dBm). Further noise improvement can be achieved by an input matching network or by transformer coupling of the input signal.

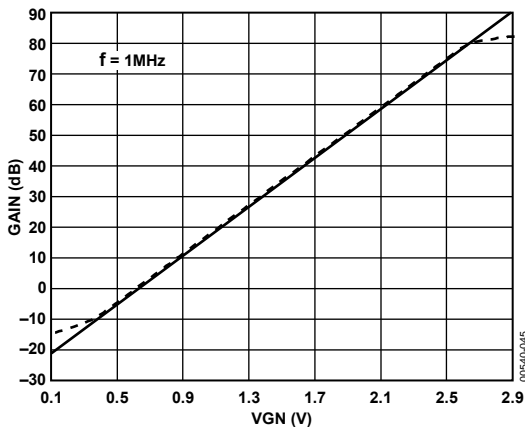

Figure 45. Cascaded Gain vs. VGN (Based on Figure 44)

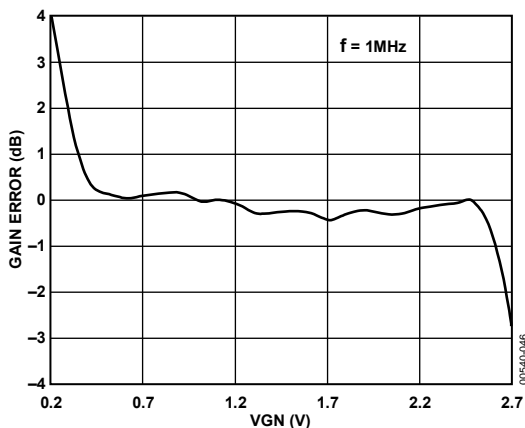

Figure 46. Cascaded Gain Error vs. VGN (Based on Figure 44)

The descriptions of the detector circuitry functions, comprising a squarer, a low-pass filter, and an integrator, follow. At this point, it is necessary to make some assumptions about the input signal. The following explanation of the detector circuitry presumes an amplitude modulated RF carrier where the modulating signal is at a much lower frequency than the RF signal. The AD835 multiplier functions as the detector by squaring the output signal presented to it by the AD604. A low-pass filter following the squaring operation removes the RF signal component at twice

the incoming signal frequency, while passing the low frequency AM information. The following integrator with a time constant of 2 ms set by R8 and C11 integrates the error signal presented by the low-pass filter and changes VG until the error signal is equal to V_{SET} .

For example, if the signal presented to the detector is $V1 = A \times \cos(\omega t)$ as indicated in Figure 44, the output of the squarer is $-(V1)^2/1$ V. The reason for all the minus signs in the detection circuitry is the necessity of providing negative feedback in the control loop; actually, if V_{SET} becomes greater than 0 V, the control loop provides positive feedback. Squaring $A \times \cos(\omega t)$ results in two terms, one at dc and one at 2ω ; the following low-pass filter passes only the $-(A)^2/2$ dc term. This dc voltage is now forced equal to the voltage, V_{SET} , by the control loop. The squarer, together with the low-pass filter, functions as a mean-square detector. As should be evident by controlling the value of V_{SET} , the amplitude of the voltage V1 can be set at the input of the AD835; if V_{SET} equals −80 mV, the AGC output signal amplitude is ±400 mV.

Figure 47 shows the control voltage, VGN, vs. the input power at frequencies of 1 MHz (solid line) and 10 MHz (dashed line) at an output regulated level of 2 dBm (800 mV p-p). The AGC threshold is evident at a P_{IN} of about −79 dBm; the highest input power that can still be accommodated is about +3 dBm. At this level, the output starts being distorted because of clipping in the preamplifier.

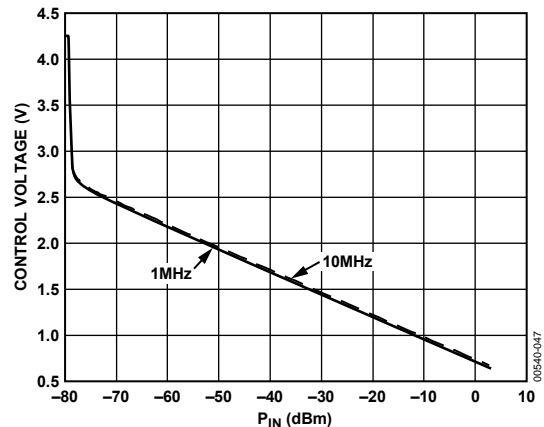

Figure 47. Control Voltage vs. Input Power of the Circuit in Figure 44

As previously mentioned, the second preamplifier can be used to extend the range of the AGC circuit in Figure 44. Figure 48 shows the modifications that must be made to Figure 46 to achieve 96 dB of gain and dynamic range. Because of the extremely high gain, the bandwidth must be limited to reject some of the noise. Furthermore, limiting the bandwidth helps suppress high-frequency oscillations. The added components act as a low-pass filter and dc block (C5 decouples the 2.5 V common-mode output of the first DSX). The ferrite bead has an impedance of about 5 Ω at 1 MHz, 30 Ω at 10 MHz, and 70 Ω at 100 MHz. The bead, combined with R2 and C6, forms a 1 MHz low-pass filter.

AD604

MEDICAL ULTRASOUND TGC DRIVING THE AD9050, A 10-BIT, 40 MSPS ADC

The AD604 is an ideal candidate for the time gain control (TGC) amplifier that is required in medical ultrasound systems to limit the dynamic range of the signal that is presented to the ADC.

Figure 52 shows a schematic of an AD604 driving an AD9050 in a typical medical ultrasound application.

The gain is controlled by means of a digital byte that is input to an AD7226 DAC that outputs the analog gain control signal. The output common-mode voltage of the AD604 is set to $V_{POS}/2$ by means of an internal voltage divider. The VOCM pin is bypassed with a $0.1\ \mu\text{F}$ capacitor to ground.

The DSX output is optionally filtered and then buffered by an AD9631 op amp, a low distortion, low noise amplifier. The op amp output is ac-coupled into the self-biasing input of an AD9050 ADC that is capable of outputting 10 bits at a 40 MSPS sampling rate.

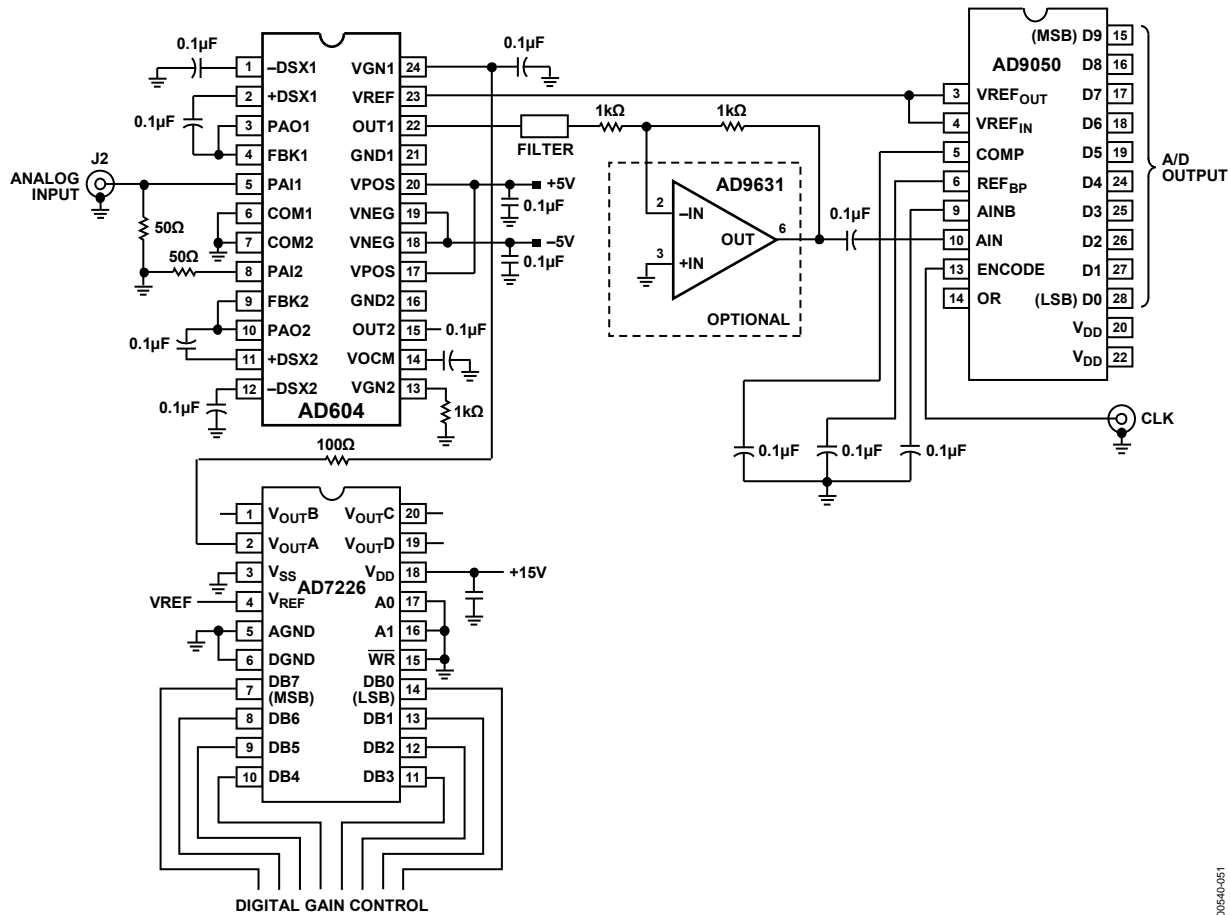
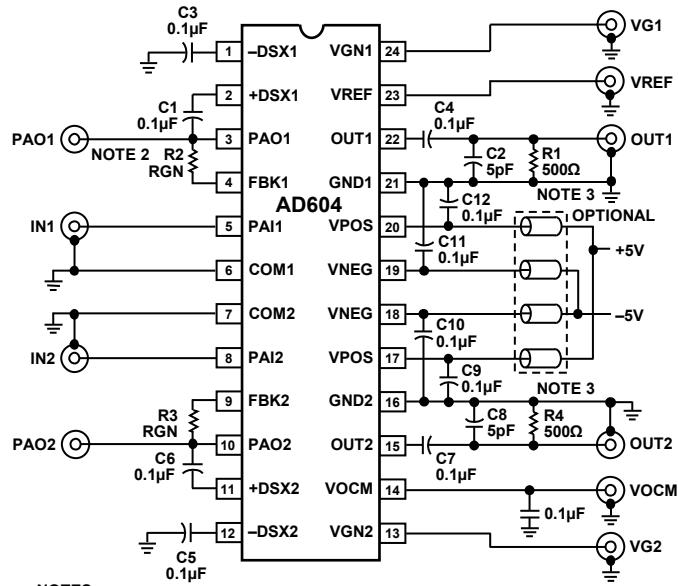

Figure 52. TGC Circuit for Medical Ultrasound Application

00540-051



- NOTES**
1. PAO1 AND PAO2 ARE USED TO MEASURE PREAMPS.
 2. RGN = 0 NOMINALLY; PREAMP GAIN = 5, RGN = OPEN; PREAMP GAIN = 10.
 3. WHEN MEASURING BW WITH 50Ω SPECTRUM ANALYZER, USE 450Ω IN SERIES.

Figure 53. Basic Test Board

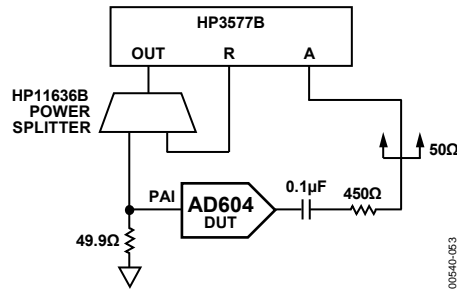

Figure 54. Setup for Gain Measurements

EVALUATION BOARD

Figure 56 is a photograph of the AD604 evaluation board assembly. Multiple input connections, testpoints, switch-selectable options, and on-board trims offer convenience when configuring the AD604 in various operating modes.

The evaluation board requires only a dual 5 V supply capable of 200 mA or higher to operate both channels. Prior to shipment, the evaluation board is fully tested. Users need only attach power supply leads and the appropriate test equipment to the board.

Because of this flexibility, some of the component positions on the board are user selectable. Installing or changing additional parts, such as gain resistor values or SMA connectors for non-standard I/O, is discretionary.

The AD604-EVALZ is fabricated on a 4-layer board with inner power and ground layers. Figure 55 is a photograph of the top views of the board, assembly and artwork layers are shown in Figure 56, a representative test setup is shown in Figure 57, and Figure 58 to Figure 62 show the artwork drawings of the evaluation board.

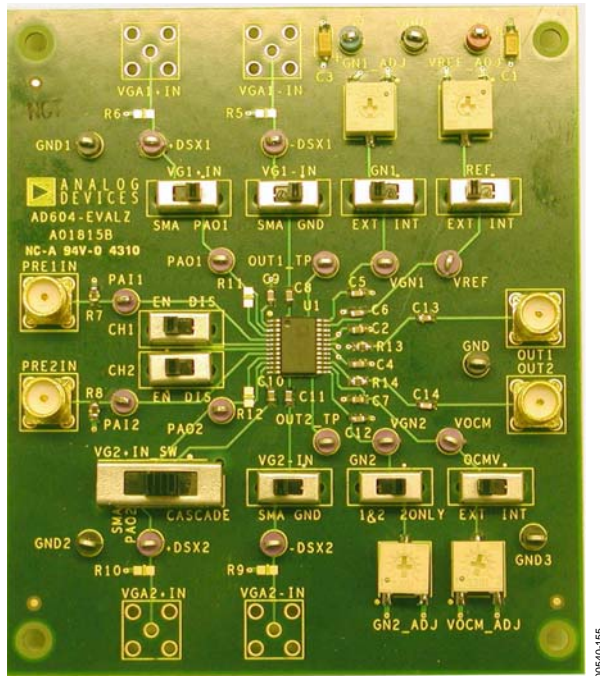

Figure 55. Top View Photograph of AD604 Evaluation Board

CONNECTING A WAVEFORM TO THE AD604-EVALZ

To test the AD604, apply the desired waveform to either or both of the preamplifier input SMA connectors, PRE1IN or PRE2IN. Referring to the schematic in Figure 63, the inputs are already terminated 49.9 Ω resistors (R7 and R8); therefore, no external terminating networks are required.

To enable the preamplifiers, insert jumpers in the JP8 and JP9 rightmost positions; this connects COM1 and COM2 to ground. Power down the preamplifiers by inserting jumpers in the JP8 and JP9 leftmost positions.

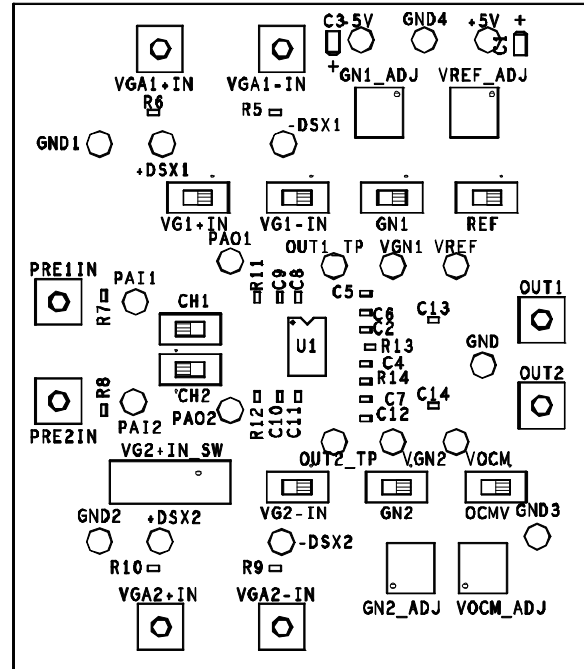

Figure 56. AD604 Evaluation Board Assembly

DSX INPUT CONNECTIONS

The VGA input configuration options are single-ended or differential. Connections are provided for each of the inputs and are labeled $VGAx+IN$ and $VGAx-IN$. Switches $VGAx+IN$ and $VGAx-IN$ select between the preamplifier outputs (PAOx) and the VGA SMA input connectors. For direct drive of the Channel VGA channels from an external source, such as a signal generator, simply use the switches to select the desired signal paths. Refer to the schematic shown in Figure 63 for circuit details.

Because the VGA section of the AD604 uses a single 5 V supply, the VGA inputs are ac-coupled. The VGA ladder network input is connected to the device $\pm DSX1/\pm DSX2$ pins, and the network impedance is nominally 200 Ω . If direct access to the DSX is desired, signals can be applied to the test loops $\pm DSX1/\pm DSX2$. Optionally, SMA connectors can be installed at the $VGAx\pm IN$ locations and 66.5 Ω , 1% resistors at R5, R6, R9, and R10 to provide an input termination value of 49.9 Ω .

Cascade VGAs to Boost Gain

The AD604 channels may be cascaded to achieve higher gain range by moving the VG2+IN_SW to its CASCADE position. The resulting single-channel gain range is 96 dB.

The gains of cascaded VGAs are controlled independently or in common. For common (parallel) control, move the gain control switch, GN2, to the 1&2 position.

To use the optional GNx_ADJ trimmers for static gain control voltages, set GN1 to EXT and GN2 to 2ONLY. For external control, connect the desired signal source to the test loops, VGNx.

PREAMPLIFIER GAIN

The default gain of the preamplifier is 20 dB, 14 dB is achieved with 0 Ω resistors in the R11 and R12 positions. The 14 dB and 20 dB preset gains are accurate because of the close matching of the internal thin film resistors. The gain accuracy after installing external resistors is subject to inherent tolerance of absolute accuracy; however, any pair of preamplifiers is reasonably matched when standard 1% SM resistors are used.

OUTPUTS

The DSX outputs are available on the OUT1 and OUT2 SMA connectors and are series terminated with decoupling capacitors and 49.9 Ω series resistors.

DC OPERATING CONDITIONS

Table 4 lists the trimmers and their functions provided for convenient dc level adjustments of gain, reference voltage, and output common-mode voltage. Table 5 lists the switches and their functions.

Table 4. Trimmer Functions

Trimmer	Function
GN1_ADJ	Optional dc level for VGA Channel 1
VREF_ADJ	Optional dc level to adjust reference voltage
VOCM_ADJ	Output common-mode voltage adjustment
GN2_ADJ	Optional dc level for VGA Channel 2

Table 5. Jumpers

Switch	Function
VG1-IN	Connects -DSX1 to the SMA connector VGA1-IN or to ground.
VG1+IN	Connects +DSX1 (ac-coupled) to the preamplifier output of Channel 1 (PAO1) or to the SMA connector VGA1+ IN.
CH1	Enables/disables Channel 1 preamp by connecting COM1 to ground (enable) or to +5V (disable).
CH2	Enables/disables Channel 2 preamp by connecting COM2 to ground (enable) or to +5V (disable).
VG2+IN_SW	Connects the +DSX input to the SMA VGA2+IN, the Channel 2 preamplifier output (PAO2), or the output of Channel 1 for a cascade connection.
VG2-IN	Connects -DSX2 to SMA VGA2-IN or to ground.
GN1	Connects the VGN1 input to trimmer GN1_ADJ gain adjust wiper or leaves the input unconnected.
REF	Connects the reference input to the VREF_ADJ trimmer or leaves the input connected.
OCMV	Connects VOCM to the common-mode voltage trimmer, VOCM_ADJ.

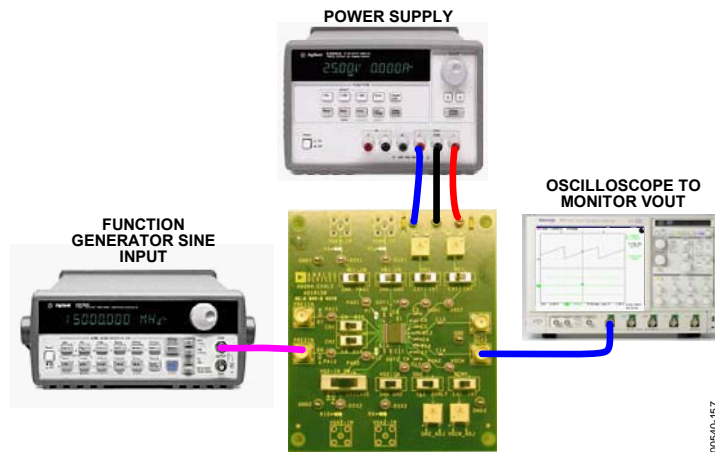

Figure 57. A Representative Test Setup of the AD604-EVALZ

00540-157

EVALUATION BOARD ARTWORK AND SCHEMATIC

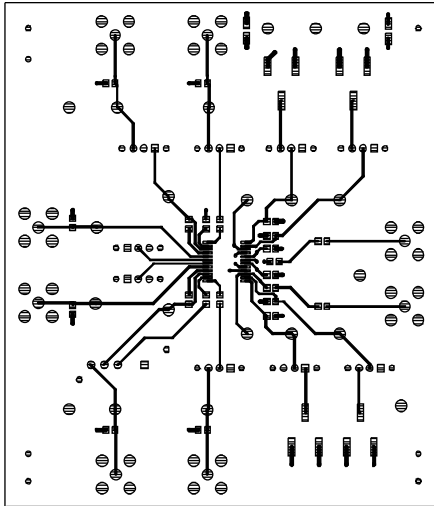

Figure 58. Component Side Copper

00540-158

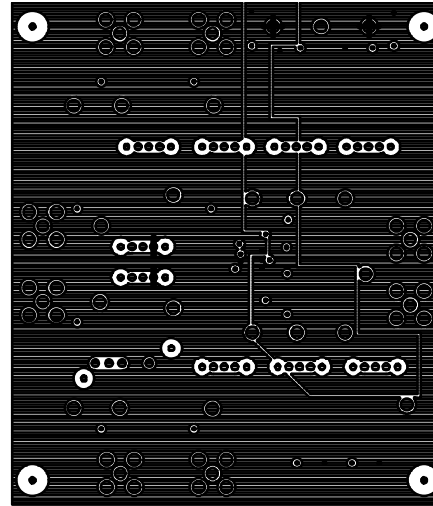

Figure 61. Internal Power Plane

00540-161

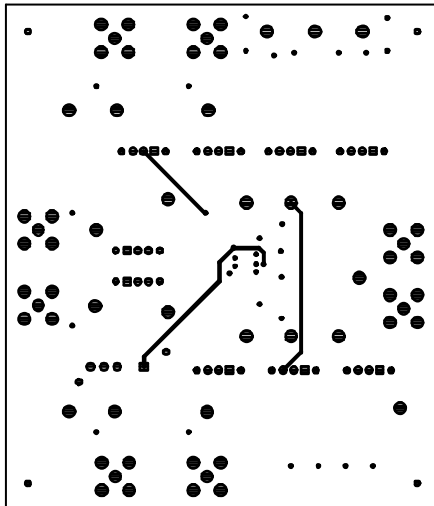

Figure 59. Secondary Side Copper

00540-159

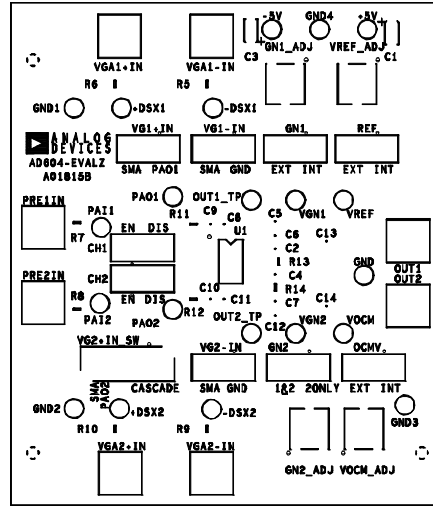

Figure 62. Component Side Silkscreen of the AD604 Evaluation Board

00540-162

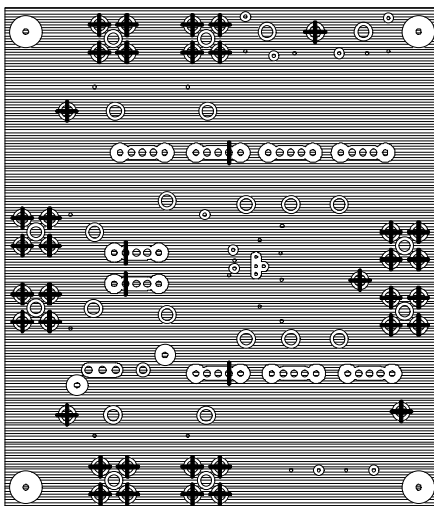
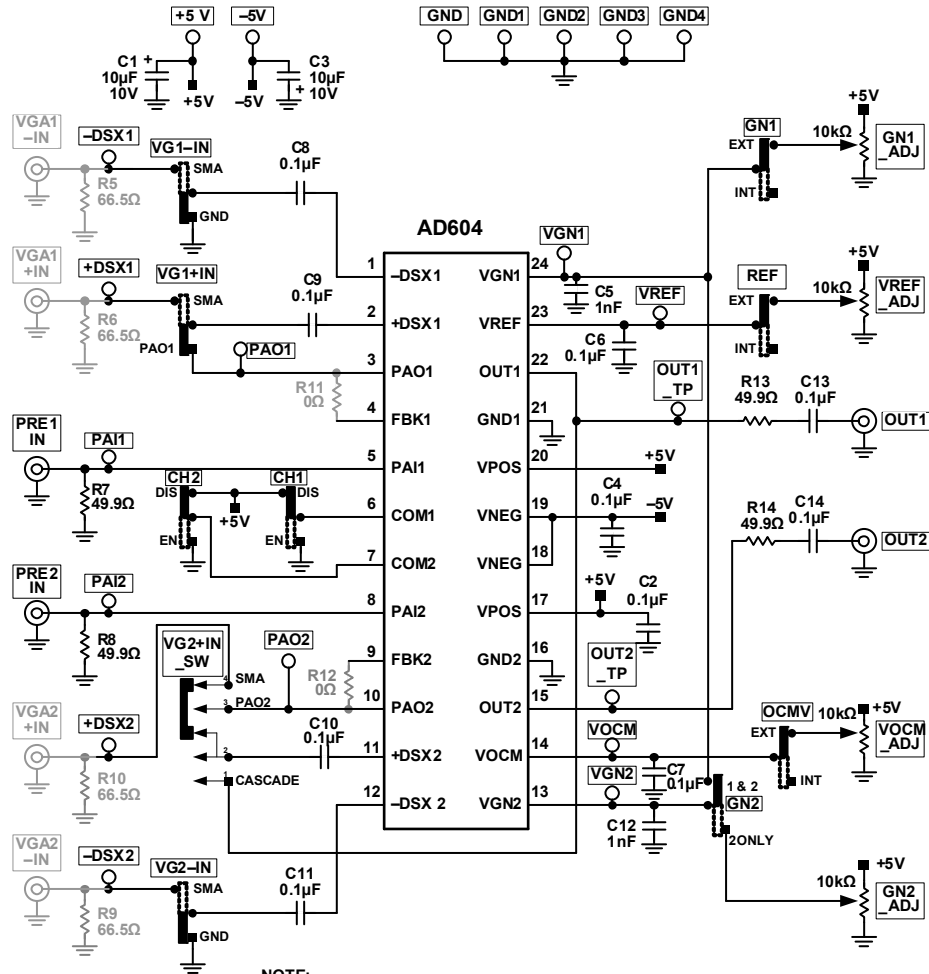

Figure 60. Internal Ground Plane

00540-160



NOTE:
PARTS IN GRAY INSTALLED AT USER DISCRETION

Figure 63. Evaluation Board Schematic

00540-163

OUTLINE DIMENSIONS

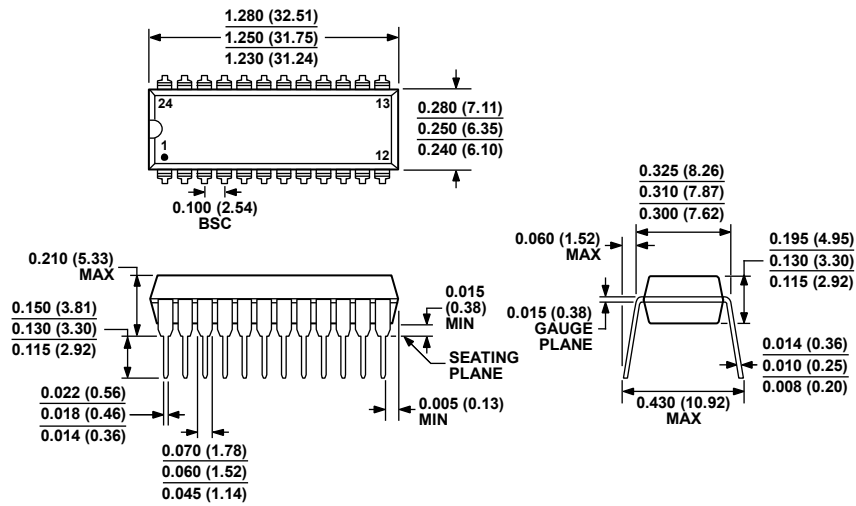

COMPLIANT TO JEDEC STANDARDS MS-001
 CONTROLLING DIMENSIONS ARE IN INCHES; MILLIMETER DIMENSIONS (IN PARENTHESES) ARE ROUNDED-OFF INCH EQUIVALENTS FOR REFERENCE ONLY AND ARE NOT APPROPRIATE FOR USE IN DESIGN. CORNER LEADS MAY BE CONFIGURED AS WHOLE OR HALF LEADS.

Figure 64. 24-Lead Plastic Dual In-Line Package [PDIP] Narrow Body (N-24-1)

Dimensions shown in inches and (millimeters)

07106E-A

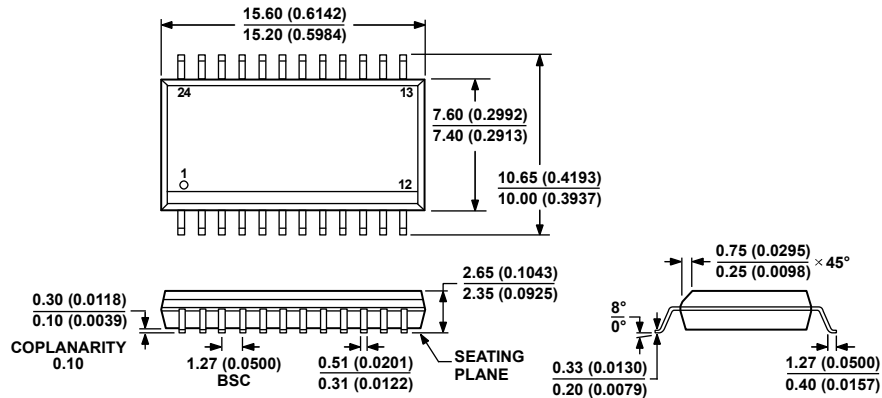

COMPLIANT TO JEDEC STANDARDS MS-013-AD
 CONTROLLING DIMENSIONS ARE IN MILLIMETERS; INCH DIMENSIONS (IN PARENTHESES) ARE ROUNDED-OFF MILLIMETER EQUIVALENTS FOR REFERENCE ONLY AND ARE NOT APPROPRIATE FOR USE IN DESIGN.

Figure 65. 24-Lead Standard Small Outline Package [SOIC_W] Wide Body (RW-24)

Dimensions shown in millimeters and (inches)

12406-2010-A

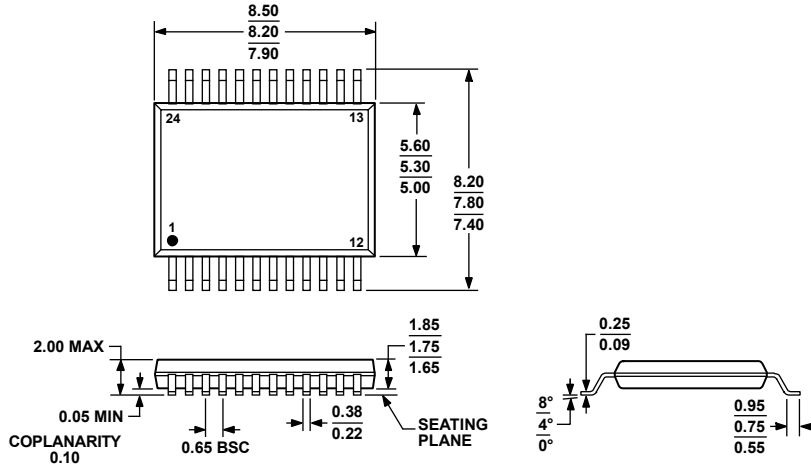

COMPLIANT TO JEDEC STANDARDS MO-150-AG
 Figure 66. 24-Lead Shrink Small Outline Package [SSOP]
 (RS-24)
 Dimensions shown in millimeters

ORDERING GUIDE

Model ¹	Temperature Range	Package Description	Package Option
AD604ANZ	-40°C to +85°C	24-Lead Plastic Dual In-Line Package [PDIP]	N-24-1
AD604AR	-40°C to +85°C	24-Lead Standard Small Outline Package [SOIC_W]	RW-24
AD604AR-REEL	-40°C to +85°C	24-Lead Standard Small Outline Package [SOIC_W]	RW-24
AD604ARZ	-40°C to +85°C	24-Lead Standard Small Outline Package [SOIC_W]	RW-24
AD604ARZ-RL	-40°C to +85°C	24-Lead Standard Small Outline Package [SOIC_W]	RW-24
AD604ARS	-40°C to +85°C	24-Lead Shrink Small Outline Package [SSOP]	RS-24
AD604ARS-REEL7	-40°C to +85°C	24-Lead Shrink Small Outline Package [SSOP]	RS-24
AD604ARSZ	-40°C to +85°C	24-Lead Shrink Small Outline Package [SSOP]	RS-24
AD604ARSZ-RL	-40°C to +85°C	24-Lead Shrink Small Outline Package [SSOP]	RS-24
AD604ARSZ-R7	-40°C to +85°C	24-Lead Shrink Small Outline Package [SSOP]	RS-24
AD604-EVALZ		Evaluation Board	

¹ Z = RoHS Compliant Part.

AD604

NOTES

NOTES

AD604

NOTES

Looking for pricing, stock, or lifecycle information?

Click below to explore more details on WIN SOURCE:

 [View AD604ARZ-RL on WIN SOURCE](#)

 [Analog Devices Inc. Information](#)

Optimize Your Supply Chain with WIN SOURCE Solutions

-  Global Sourcing Solution
-  Obsolete Management
-  Cost Control Management
-  Shortage Management
-  Alternative Solution
-  Excess Inventory Management