



**THE DATASHEET OF
RCLAMP1851Y.TFT**



PROTECTION PRODUCTS - RailClamp®

Description

RailClamp® TVS diodes are ultra low capacitance devices designed to protect sensitive electronics from damage or latch-up due to ESD, EFT, and EOS. They are designed for use on high speed ports in applications such as cell phones, notebook computers, and other portable electronics. These devices offer desirable characteristics for board level protection including fast response time, low operating and clamping voltage, and no device degradation.

RClamp®1851Y is specifically designed for protection of Near Field Communications (NFC) interfaces. It features extremely good ESD protection characteristics including a low typical dynamic resistance of <0.1 Ohms, low peak ESD clamping voltage, and high ESD withstand voltage (+/-18kV contact per IEC 61000-4-2). Low typical capacitance (0.35pF at VR=0V) means that RClamp1851Y will not create harmonic distortion in the RF signal. This device is bidirectional and has a working voltage of 18V for use on NFC resonator circuits without signal clipping.

RClamp1851Y is in a 2-pin SLP0603P2X3E package measuring 0.6 x 0.3 mm with a nominal height of 0.25mm. Leads are finished with lead-free NiAu. The combination of working voltage, low dynamic resistance, and low capacitance makes this device ideal for use on NFC antenna circuits, signal lines, and FM antennas in portable devices.

Features

- ◆ High ESD withstand Voltage: +/-**18kV** (Contact/Air) per **IEC 61000-4-2**
- ◆ Able to withstand over 1000 ESD strikes per IEC 61000-4-2 Level 4
- ◆ Ultra-small **0201 package**
- ◆ Protects one high speed data line
- ◆ Working voltage: +/- 18V
- ◆ Low capacitance: **0.35pF typical**
- ◆ Extremely low dynamic resistance: **<0.10 Ohms (Typ)**
- ◆ Low ESD clamping voltage
- ◆ Solid-state silicon-avalanche technology

Mechanical Characteristics

- ◆ SLP0603P2X3E Package
- ◆ Pb-Free, Halogen Free, RoHS/WEEE Compliant
- ◆ Nominal Dimensions: 0.6 x 0.3 x 0.25 mm
- ◆ Lead Finish: NiAu
- ◆ Marking: Marking Code
- ◆ Packaging: Tape and Reel

Applications

- ◆ Near Field Communication (NFC) lines
- ◆ RF signal lines
- ◆ FM Antenna

Nominal Dimensions

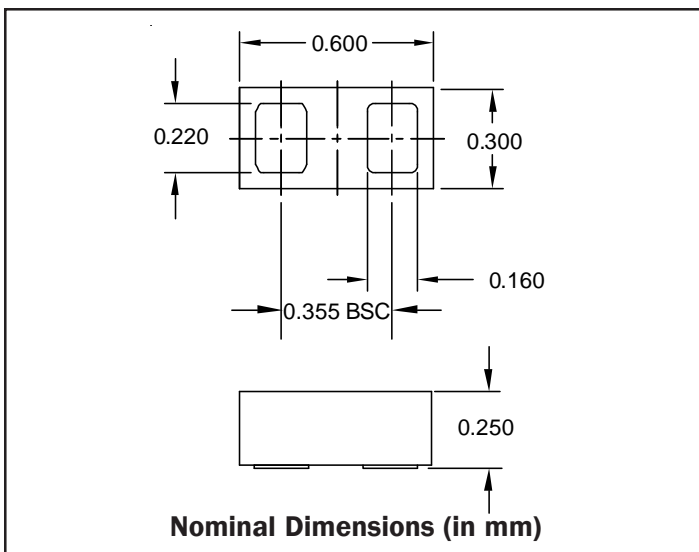

Schematic

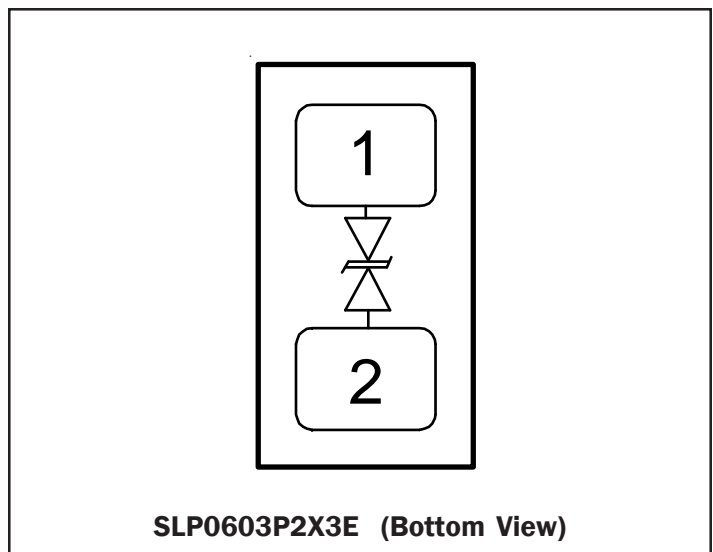

PROTECTION PRODUCTS

Absolute Maximum Rating

Rating	Symbol	Value	Units
Peak Pulse Power (tp = 8/20μs)	P_{pk}	60	Watts
Maximum Peak Pulse Current (tp = 8/20μs)	I_{pp}	3	Amps
ESD per IEC 61000-4-2 (Air) ¹ ESD per IEC 61000-4-2 (Contact) ¹	V_{ESD}	+/- 18 +/- 18	kV
Operating Temperature	T_J	-40 to +85	°C
Storage Temperature	T_{STG}	-55 to +150	°C

Electrical Characteristics (T=25°C)

Parameter	Symbol	Conditions	Minimum	Typical	Maximum	Units
Reverse Stand-Off Voltage	V_{RWM}	Pin 1 to 2 or 2 to 1			18	V
Trigger Voltage ²	V_{TRIG}	tp = 0.2/100ns		23		V
Reverse Leakage Current	I_R	$V_{RWM} = 18V, T=25^\circ C$ Pin 1 to 2 or 2 to 1		<1	50	nA
ESD Clamping Voltage ²	V_C	$I_{PP} = 4A,$ t1p = 0.2/100ns		11		V
ESD Clamping Voltage ²	V_C	$I_{PP} = 16A,$ t1p = 0.2/100ns		12		V
Dynamic Resistance ^{2, 3}	R_D	tp = 0.2/100ns		0.08		Ohms
Junction Capacitance	C_J	$V_R = 0V, f = 1MHz$		0.35	0.45	pF

Notes

- 1)ESD gun return path connected to ESD ground reference plane.
- 2)Transmission Line Pulse Test (TLP) Settings: $t_p = 100ns, t_r = 0.2ns, I_{TLP}$ and V_{TLP} averaging window: $t_1 = 70ns$ to $t_2 = 90ns$.
- 3) Dynamic resistance calculated from $I_{TLP} = 4A$ to $I_{TLP} = 16A$

PROTECTION PRODUCTS

Typical Characteristics

ESD Clamping (+8kV Contact per IEC 61000-4-2)

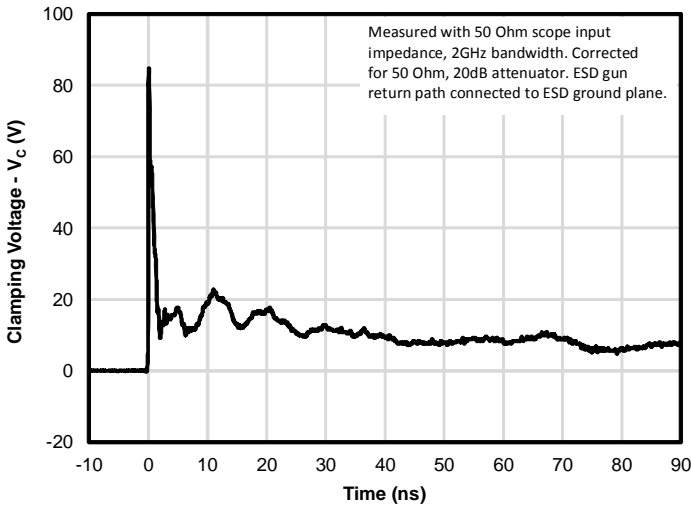

ESD Clamping (-8kV Contact per IEC 61000-4-2)

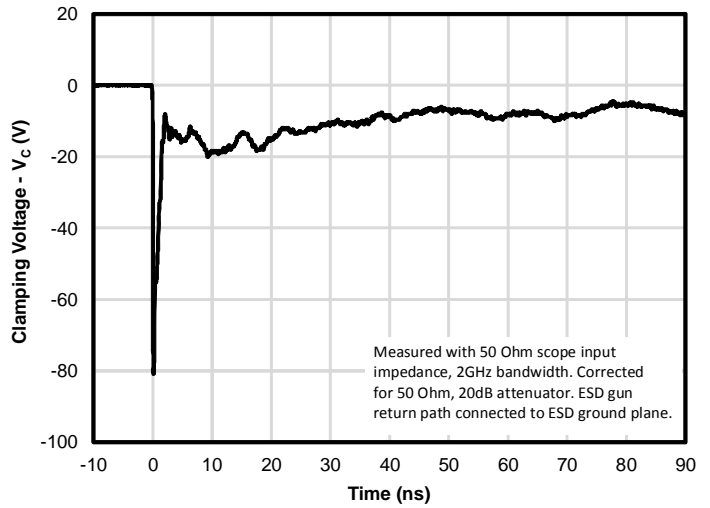

TLP Characteristic (Positive)

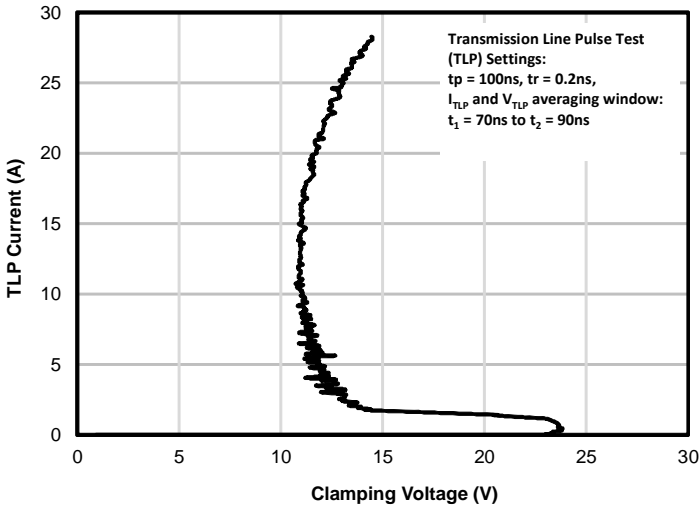

TLP Characteristic (Negative)

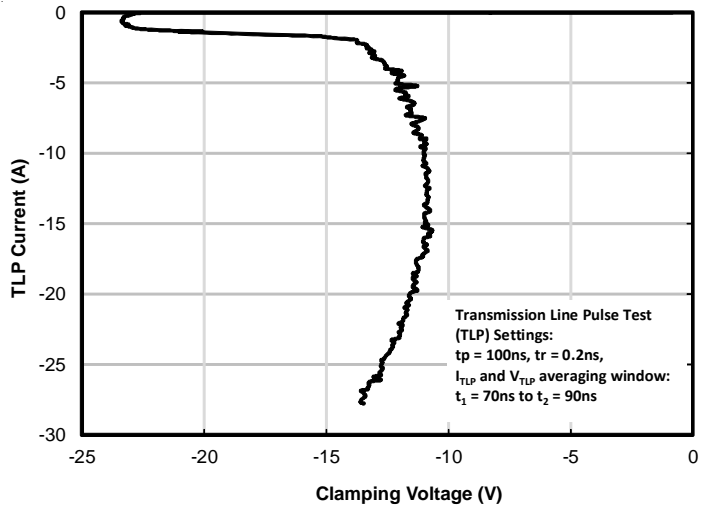

Junction Capacitance vs. Reverse Voltage

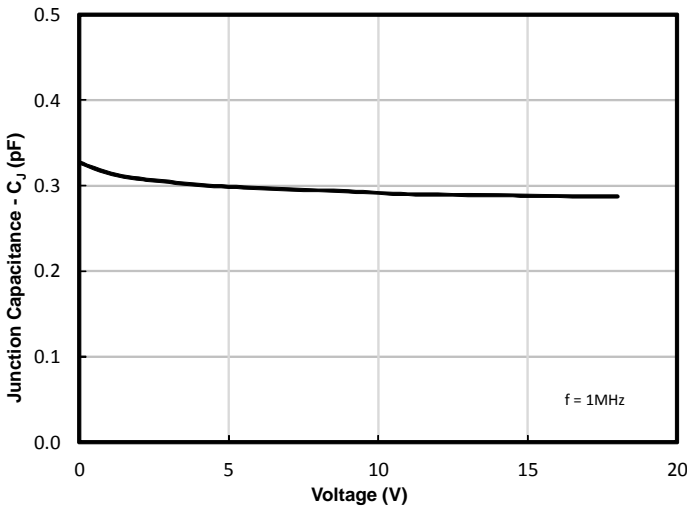

Typical Insertion Loss S21

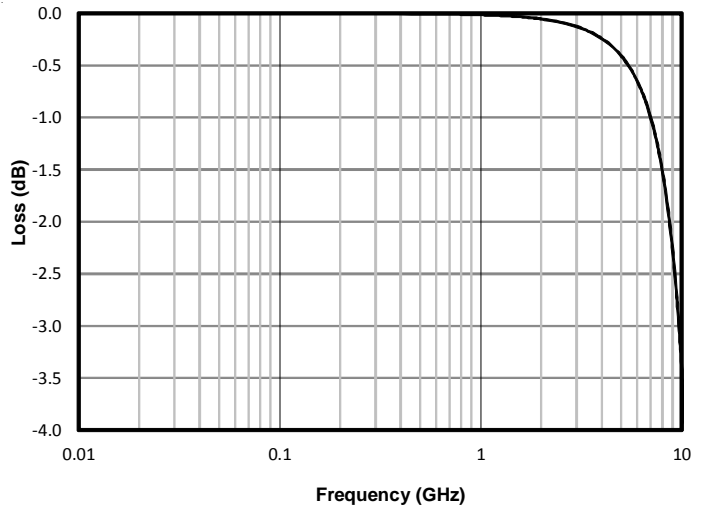

PROTECTION PRODUCTS

Applications Information

ESD Protection of NFC Interfaces

The Near Field Communication (NFC) antenna is usually connected to the NFC controller IC via contact points on the phone. These contact points are user accessible and therefore may be subjected to ESD strikes. External protection (TVS) devices should be placed between the antenna and the NFC chip interface. The working voltage of the TVS should be high enough as not to clip the NFC signal. Additionally, the capacitance of the device should be minimized in order to avoid harmonic distortion of the RF signal. RClamp1851Y meets these requirements and also features extremely low dynamic resistance (<0.1 Ohms) resulting in low ESD clamping voltage. The low dynamic resistance also helps insure protection for Schottky diodes that may be used in the NFC circuit. RClamp1851Y is designed to work on NFC circuits with AC signals as high as 18V. An example protection circuit using RClamp1851Y is shown below in Figure 1.

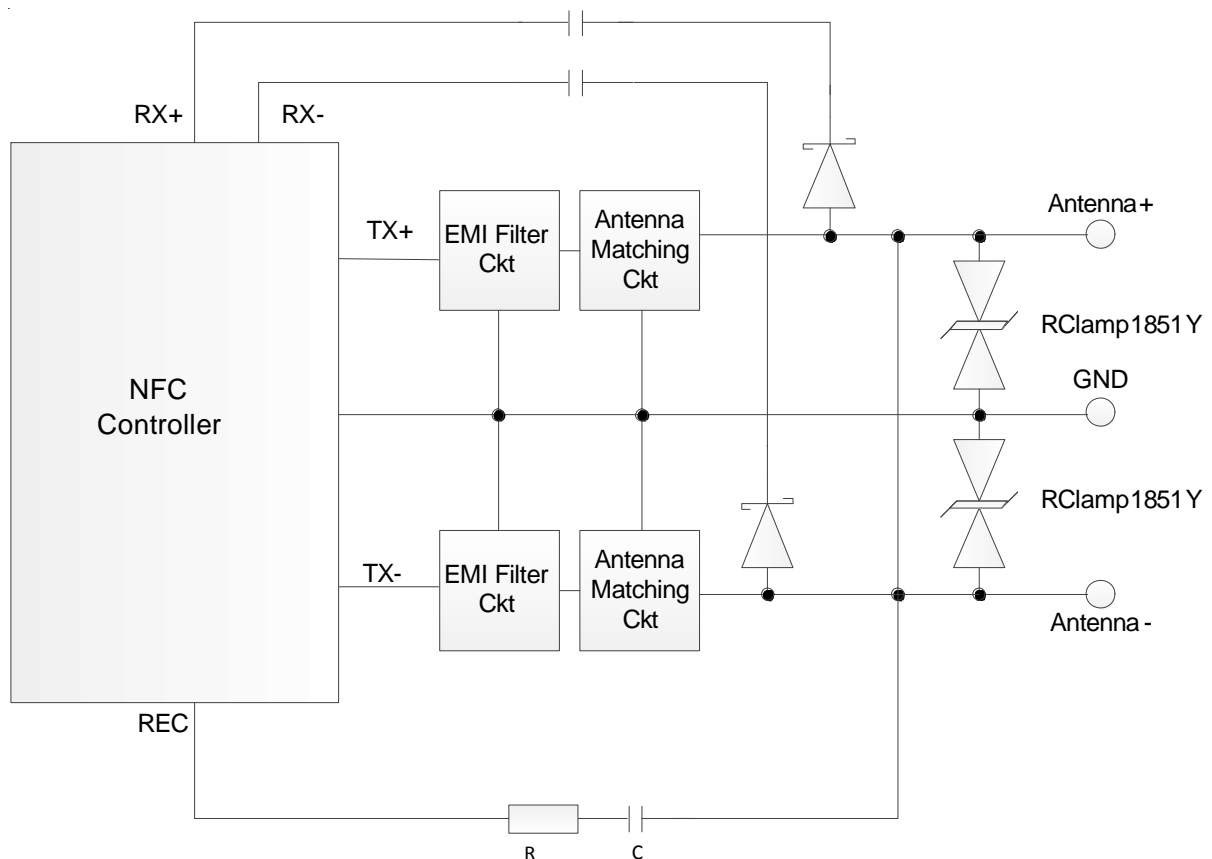
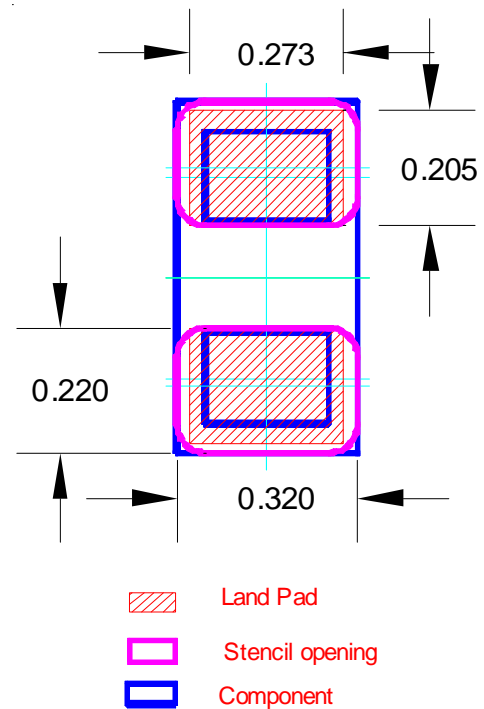

Figure 1 - NFC Protection Example

PROTECTION PRODUCTS
Applications Information
Assembly Guidelines

The small size of this device means that some care must be taken during the mounting process to insure reliable solder joints. The figure at the right details Semtech's recommended aperture based on the assembly guidelines detailed in the table below. Note that these are only recommendations and should serve only as a starting point for design since there are many factors that affect the assembly process. Exact manufacturing parameters will require some experimentation to get the desired solder application.

Assembly Parameter	Recommendation
Solder Stencil Design	Laser cut, Electro-polished
Aperture shape	Rectangular with rounded corners
Solder Stencil Thickness	0.100 mm (0.004")
Solder Paste Type	Type 4 size sphere or smaller
Solder Reflow Profile	Per JEDEC J-STD-020
PCB Solder Pad Design	Non-Solder mask defined
PCB Pad Finish	OSP OR NiAu

Recommended Mounting Pattern

PROTECTION PRODUCTS

Outline Drawing - SLP0603P2X3E

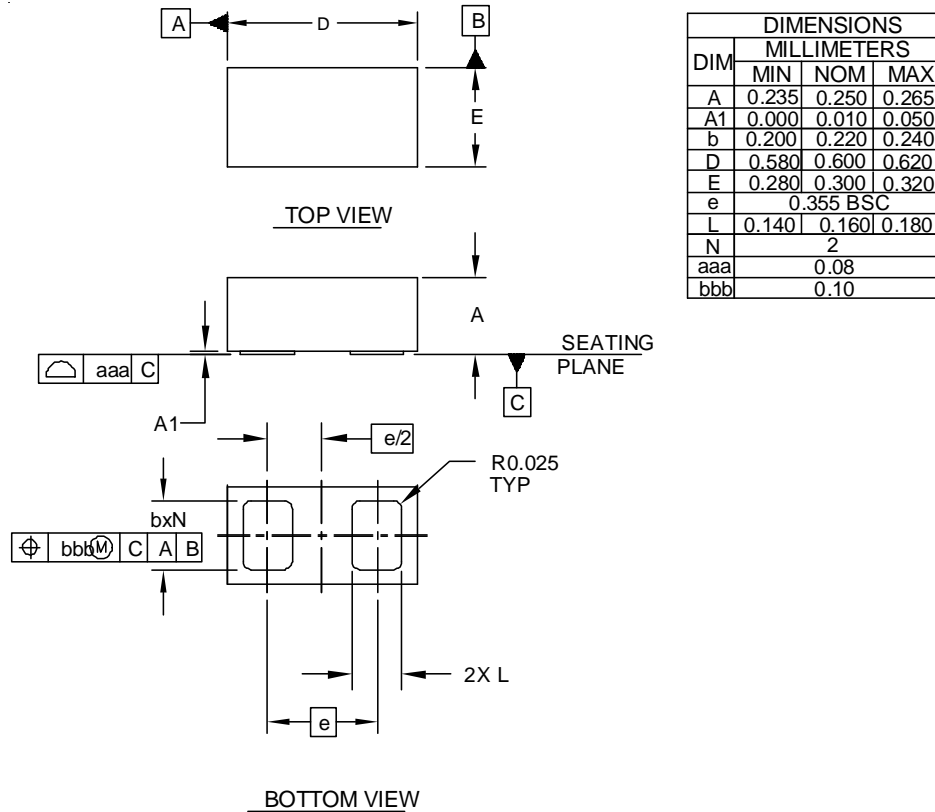

- NOTES:
1. CONTROLLING DIMENSIONS ARE IN MILLIMETERS(ANGLES IN DEGREES).

Land Pattern - SLP0603P2X3E

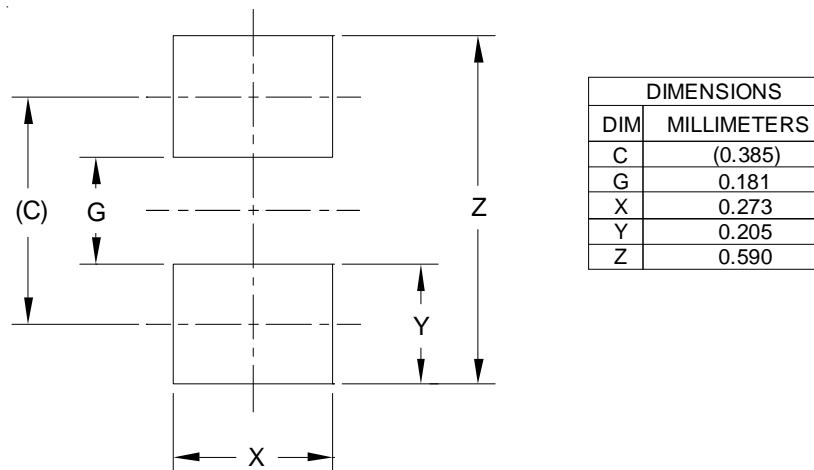

- NOTES:
1. CONTROLLING DIMENSIONS ARE IN MILLIMETERS (ANGLES IN DEGREES).
 2. THIS LAND PATTERN IS FOR REFERENCE PURPOSES ONLY .
CONSULT YOUR MANUFACTURING GROUP TO ENSURE YOUR
COMPANY'S MANUFACTURING GUIDELINES ARE MET .

PROTECTION PRODUCTS

Marking Code

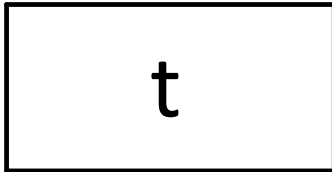

Ordering Information

Part Number	Qty per Reel	Pocket Pitch	Reel Size
RClamp1851Y.TFT	15,000	2mm	7 Inch

Notes:

RailClamp and RClamp are trademarks of Semtech Corporation

Note:
Device is electrically symmetrical

Carrier Tape Specification

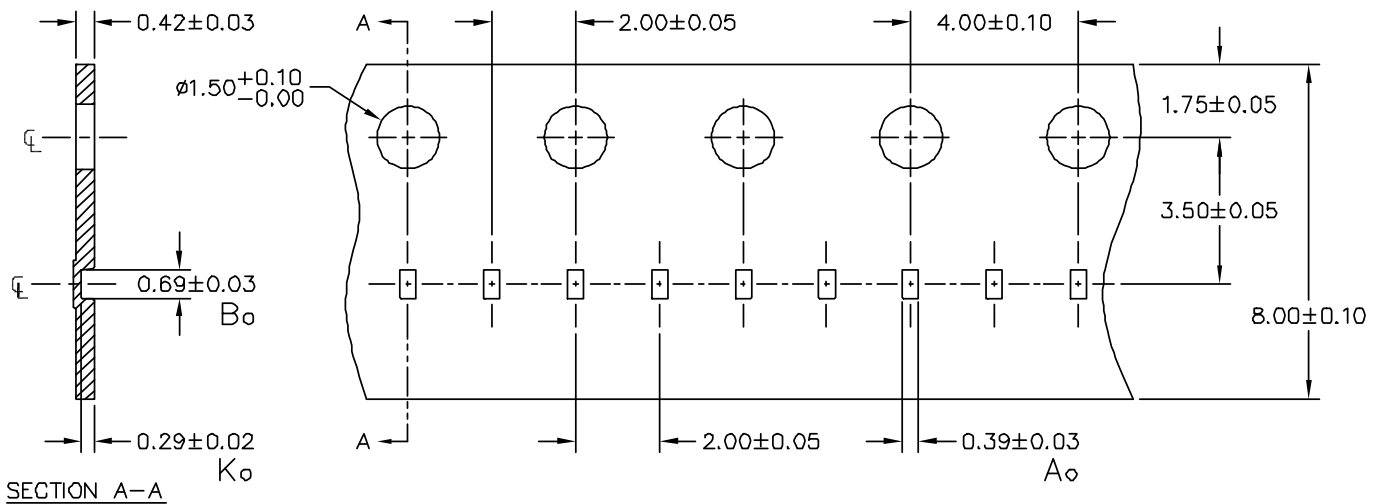

NOTES: ALL DIMENSIONS IN MILLIMETERS UNLESS OTHERWISE SPECIFIED.

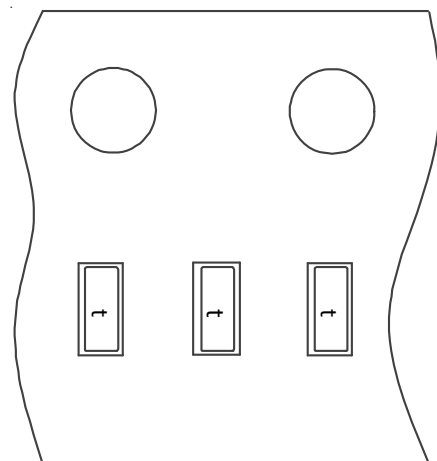

Device Orientation in Tape

Contact Information

Semtech Corporation
Protection Products Division
200 Flynn Rd., Camarillo, CA 93012
Phone: (805)498-2111 FAX (805)498-3804

Looking for pricing, stock, or lifecycle information?

Click below to explore more details on WIN SOURCE:

- ⊖ [View RCLAMP1851Y.TFT on WIN SOURCE](#)
- ⊖ [Semtech Corporation](#) Information

Optimize Your Supply Chain with WIN SOURCE Solutions

- ✓ Global Sourcing Solution
- ✓ Obsolete Management
- ✓ Cost Control Management
- ✓ Shortage Management
- ✓ Alternative Solution
- ✓ Excess Inventory Management