



**THE DATASHEET OF
SKY13358-388LF**



DATA SHEET

SKY13358-388LF: 0.1–3.0 GHz SP5T Switch

Applications

- 2G/3G cellular infrastructure

Features

- Broadband frequency range: 0.1 to 3.0 GHz
- Low insertion loss: 0.8 dB typical @ 2.2 GHz
- High isolation: 24 dB typical @ 2.2 GHz
- CMOS/TTL compatible control voltages: 0/1.5-3.5 V
- Small, QFN (16-pin, 2.3 x 2.3 mm) Pb-free package (MSL1, 260 °C per JEDEC J-STD-020)

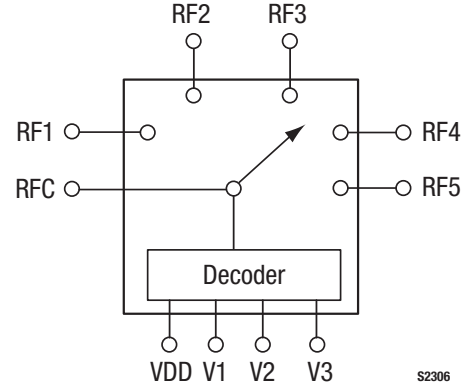

Figure 1. SKY13358-388LF Block Diagram



Skyworks Green™ products are compliant with all applicable legislation and are halogen-free. For additional information, refer to *Skyworks Definition of Green™*, document number SQ04-0074.

Description

The SKY13358-388LF is a GaAs pHEMT Single-Pole, Five-Throw (SP5T) switch with an internal CMOS decoder. The high linearity performance and low insertion loss achieved by the SKY13358-388LF make it an ideal choice for cellular infrastructure applications.

Switching is controlled by three CMOS/TTL compatible control voltage inputs (V1, V2, and V3). Depending on the logic voltage level applied to the control pins, the RFC (RF common) pin is connected to one of five switched RF outputs (RF1, RF2, RF3, RF4, or RF5) through a low insertion loss path while the path between the RFC pin and the other RF pins is in a high isolation state. External DC blocking capacitors are required on the RF paths.

The SKY13358-388LF is manufactured in a compact, 16-pin 2.3 x 2.3 mm Quad Flat No-Lead (QFN) package.

A functional block diagram is shown in Figure 1. The pin configuration and package are shown in Figure 2. Signal pin assignments and functional pin descriptions are provided in Table 1.

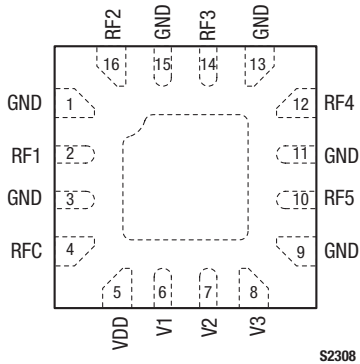

Figure 2. SKY13358-388LF Pinout – 16-Pin QFN (Top View)

Table 1. SKY13358-388LF Signal Descriptions

Pin #	Name	Description	Pin #	Name	Description
1	GND	Ground	9	GND	Ground
2	RF1	RF output port 1. Must be DC-blocked for proper operation.	10	RF5	RF output port 5. Must be DC-blocked for proper operation.
3	GND	Ground	11	GND	Ground
4	RFC	RF common input (antenna) port. Must be DC-blocked for proper operation.	12	RF4	RF output port 4. Must be DC-blocked for proper operation.
5	VDD	DC power supply.	13	GND	Ground
6	V1	DC control voltage 1. See Table 4.	14	RF3	RF output port 3. Must be DC-blocked for proper operation.
7	V2	DC control voltage 2. See Table 4.	15	GND	Ground
8	V3	DC control voltage 3. See Table 4.	16	RF2	RF output port 2. Must be DC-blocked for proper operation.

Note: Exposed backside ground pad must be properly grounded through a low impedance path.

Functional Description

The SKY13358-388LF is comprised of a CMOS decoder that enables three control lines and five RF ports. The decoder is internally connected to a GaAs pHEMT RF switch. Depending on the logic voltage level applied to the control pins, the RFC pin is connected to one of five switched RF outputs (RF1, RF2, RF3, RF4, or RF5) by a low insertion loss path, while maintaining a high isolation path to the alternate ports.

Startup time is defined as the time from when VDD is applied to when the switch is active. Once the startup time has passed, the control voltages V1 and V2 can be applied. RF power should not be applied during the startup time or damage to the device could result.

The recommended startup sequence is:

Step 1: Apply VDD.

Step 2: Apply V1, V2, and V3.

Step 3: Apply RF input.

The device must be turned off in the reverse order.

When VDD is not applied, the device is considered off or inactive. All arms of the switch remain on in this state, creating a poor five-way power splitter. The return loss of all RF ports is very low in this state. RF should not be applied when VDD is not present and should only be used to conserve current.

Electrical and Mechanical Specifications

The absolute maximum ratings of the SKY13358-388LF are provided in Table 2. Electrical specifications are provided in Table 3.

Typical performance characteristics of the SKY13358-388LF are illustrated in Figures 3, 4, and 5.

The state of the SKY13358-388LF is determined by the logic provided in Table 4.

Table 2. SKY13358-388LF Absolute Maximum Ratings

Parameter	Symbol	Minimum	Maximum	Units
Power supply (VDD)	V _{DD}		3.5	V
Control voltage (V1, V2, V3)	V _{CTL}		V _{DD}	V
RF input power	P _{IN}		+38	dBm
Storage temperature	T _{STG}	-40	+125	°C
Operating temperature	T _{OP}	-40	+85	°C
Electrostatic Discharge: Charged Device Model (CDM), Class 4 Human Body Model (HBM), Class 0 Machine Model (MM), Class A	ESD		1000 150 100	V V V

Note: Exposure to maximum rating conditions for extended periods may reduce device reliability. There is no damage to device with only one parameter set at the limit and all other parameters set at or below their nominal value. Exceeding any of the limits listed here may result in permanent damage to the device.

CAUTION: Although this device is designed to be as robust as possible, Electrostatic Discharge (ESD) can damage this device. This device must be protected at all times from ESD. Static charges may easily produce potentials of several kilovolts on the human body or equipment, which can discharge without detection. Industry-standard ESD precautions should be used at all times.

Table 3. SKY13358-388LF Electrical Specifications (1 of 2) (Note 1)

(V_{DD} = 2.5 V, V1 = V2 = V3 = 0/1.8 V, T_{OP} = +25 °C, P_{IN} = 0 dBm, Characteristic Impedance [Z₀] = 50 Ω, Unless Otherwise Noted)

Parameter	Symbol	Test Condition	Min	Typical	Max	Units
RF Specifications						
Insertion loss	IL	RFC to RF1/2/3/4/5				
		0.1 to 1.0 GHz		0.50	0.55	dB
		1.0 to 2.2 GHz		0.80	0.90	dB
Isolation	Iso	RFC to RF1/2/3/4/5				
		0.1 to 1.0 GHz	29	30		dB
		1.0 to 2.2 GHz	23	24		dB
Return loss	IS111	RFC to RF1/2/3/4/5				
		0.1 to 1.0 GHz	18	20		dB
		1.0 to 2.2 GHz	14	15		dB
2 nd Order Intermodulation Distortion	IMD2	RFC to RF1/2/3/4/5				
		f1 = 1.95 GHz @ +20 dBm, f2 = 0.19 GHz @ -15 dBm, worst case over phase		-91	-89	dBm
		2.2 to 3.0 GHz	18	13		dB
3 rd Order Intermodulation Distortion	IMD3	RFC to RF1/2/3/4/5				
		f1 = 1.95 GHz @ +20 dBm, f2 = 1.76 GHz @ -15 dBm, worst case over phase		-98	-95	dBm
		2.2 to 3.0 GHz	12	13		dB
1 dB Input Compression Point	IP1dB	0.1 to 2.2 GHz	+37.0	+37.5		dBm
2 nd harmonic	2fo	P _{IN} = +24 dBm @ 900 MHz		-77	-75	dBc
3 rd harmonic	3fo	P _{IN} = +24 dBm @ 900 MHz		-90	-85	dBc

Table 3. SKY13358-388LF Electrical Specifications (2 of 2) (Note 1)

(V_{DD} = 2.5 V, V₁ = V₂ = V₃ = 0/1.8 V, T_{OP} = +25 °C, P_{IN} = 0 dBm, Characteristic Impedance [Z₀] = 50 Ω, Unless Otherwise Noted)

Parameter	Symbol	Test Condition	Min	Typical	Max	Units
Switching Speed Specifications						
Switching characteristics:						
On time		50% V _{CTL} to 90% RF on		0.7		μs
Off time		50% V _{CTL} to 10% RF off		0.1		μs
Rise time		10% RF to 90% RF rise		0.2		μs
Fall time		90% RF to 10% RF fall		0.1		μs
Startup time (wait time required from when V _{DD} is applied until control voltage can be applied)				25		μs
DC Specifications						
Control voltage (V ₁ , V ₂ , V ₃):	V _{CTL}					
high			1.5	1.8	V _{DD}	V
low			0		0.2	V
Control current:	I _{CC}					
high		V _{1/2/3} = 1.5 V to V _{DD}		0.01		μA
low		V _{1/2/3} = 0 to 0.2 V		0.01		μA
Supply voltage	V _{DD}		1.80	2.85	3.50	V
Supply current	I _{DD}			65	125	μA

Note 1: Performance is guaranteed only under the conditions listed in this Table.

Typical Performance Characteristics

($V_{DD} = 2.5\text{ V}$, $V_1 = V_2 = V_3 = 0/1.8\text{ V}$, $T_{OP} = +25\text{ }^\circ\text{C}$, $P_{IN} = 0\text{ dBm}$, Characteristic Impedance [Z_0] = $50\ \Omega$, Unless Otherwise Noted)

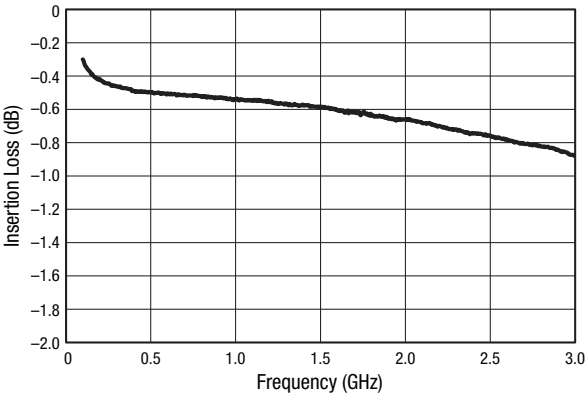

Figure 3. Insertion Loss vs Frequency

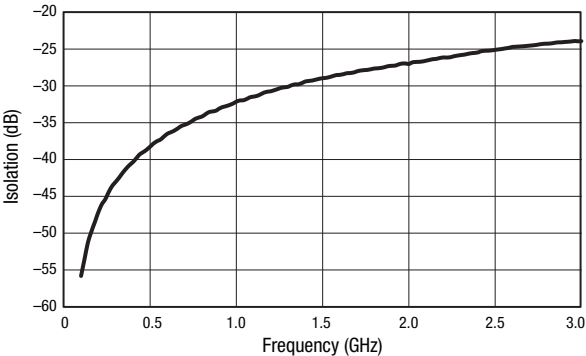

Figure 4. Average Isolation vs Frequency

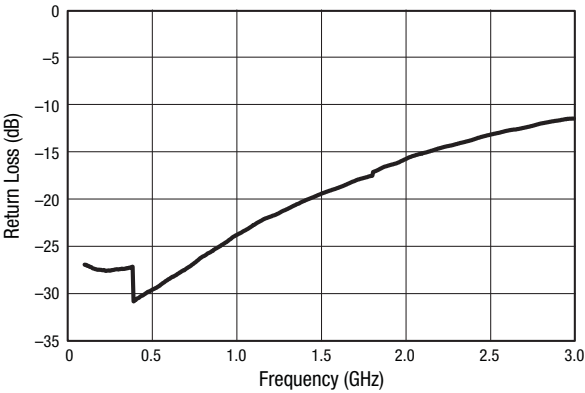

Figure 5. Return Loss vs Frequency

Table 4. SKY13358-388LF Truth Table

V1 (Pin 6)	V2 (Pin 7)	V3 (Pin 8)	RFC (Pin 4) to RF1 (Pin 2)	RFC (Pin 4) to RF2 (Pin 16)	RFC (Pin 4) to RF3 (Pin 14)	RFC (Pin 4) to RF4 (Pin 12)	RFC (Pin 4) to RF5 (Pin 10)
1	0	1	Insertion loss	Isolation	Isolation	Isolation	Isolation
1	1	0	Isolation	Insertion loss	Isolation	Isolation	Isolation
1	0	0	Isolation	Isolation	Insertion loss	Isolation	Isolation
0	X	0	Isolation	Isolation	Isolation	Insertion loss	Isolation
0	X	1	Isolation	Isolation	Isolation	Isolation	Insertion loss

Note: "1" = +1.5 V to V_{DD}
 "0" = 0 V to +0.2 V
 "X" = don't care

Evaluation Board Description

The SKY13358-388LF Evaluation Board is used to test the performance of the SKY13358-388LF SP5T Switch. An Evaluation Board schematic diagram is provided in Figure 6. An assembly drawing for the Evaluation Board is shown in Figure 7.

Package Dimensions

The PCB layout footprint for the SKY13358-388LF is provided in Figure 8. Typical case markings are shown in Figure 9. Package dimensions for the 16-pin QFN are shown in Figure 10, and tape and reel dimensions are provided in Figure 11.

Package and Handling Information

Instructions on the shipping container label regarding exposure to moisture after the container seal is broken must be followed. Otherwise, problems related to moisture absorption may occur when the part is subjected to high temperature during solder assembly.

The SKY13358-388LF is rated to Moisture Sensitivity Level 1 (MSL1) at 260 °C. It can be used for lead or lead-free soldering. For additional information, refer to the Skyworks Application Note, *Solder Reflow Information*, document number 200164.

Care must be taken when attaching this product, whether it is done manually or in a production solder reflow environment. Production quantities of this product are shipped in a standard tape and reel format.

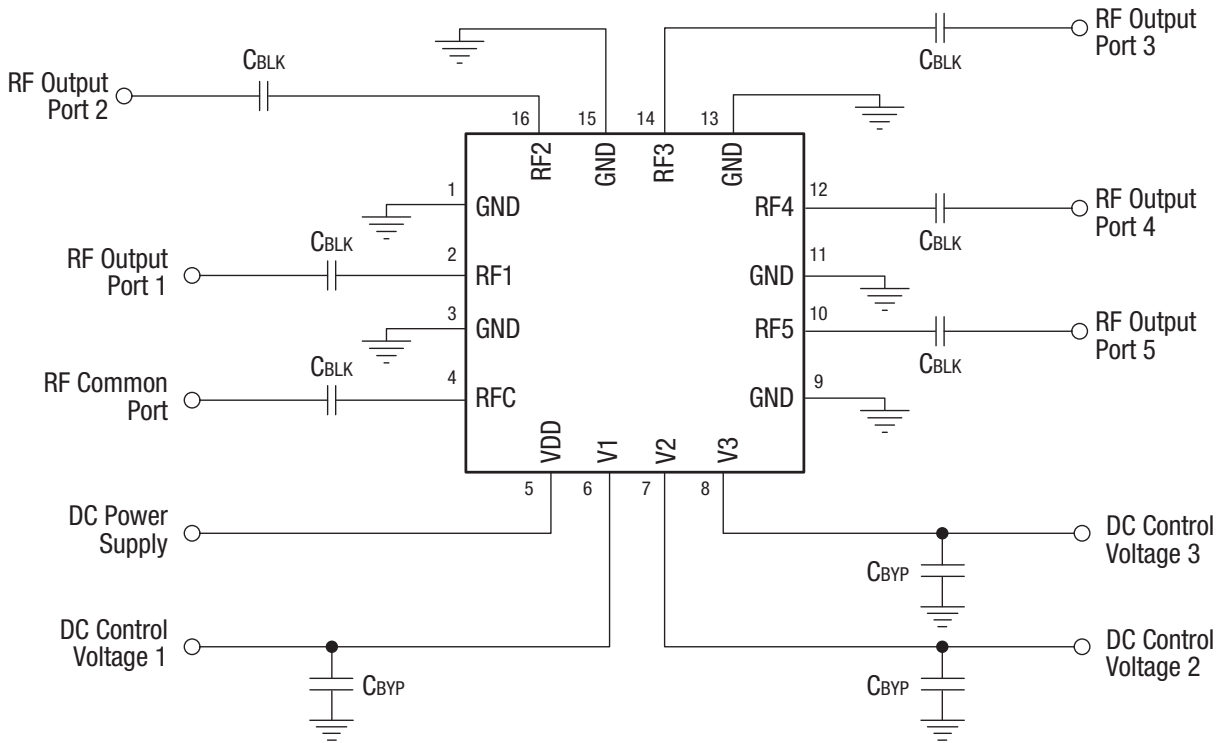

S2310

Figure 6. SKY13358-388LF Evaluation Board Schematic

Table 6. SKY13358-388LF Evaluation Board Bill of Materials

Component	Value	Size	Manufacturer	Characteristic
CBL	56 pF	0402	Murata GRM Series	DC blocking capacitor
CBYP	100 pF	0402	Murata GRM Series	Decoupling capacitor

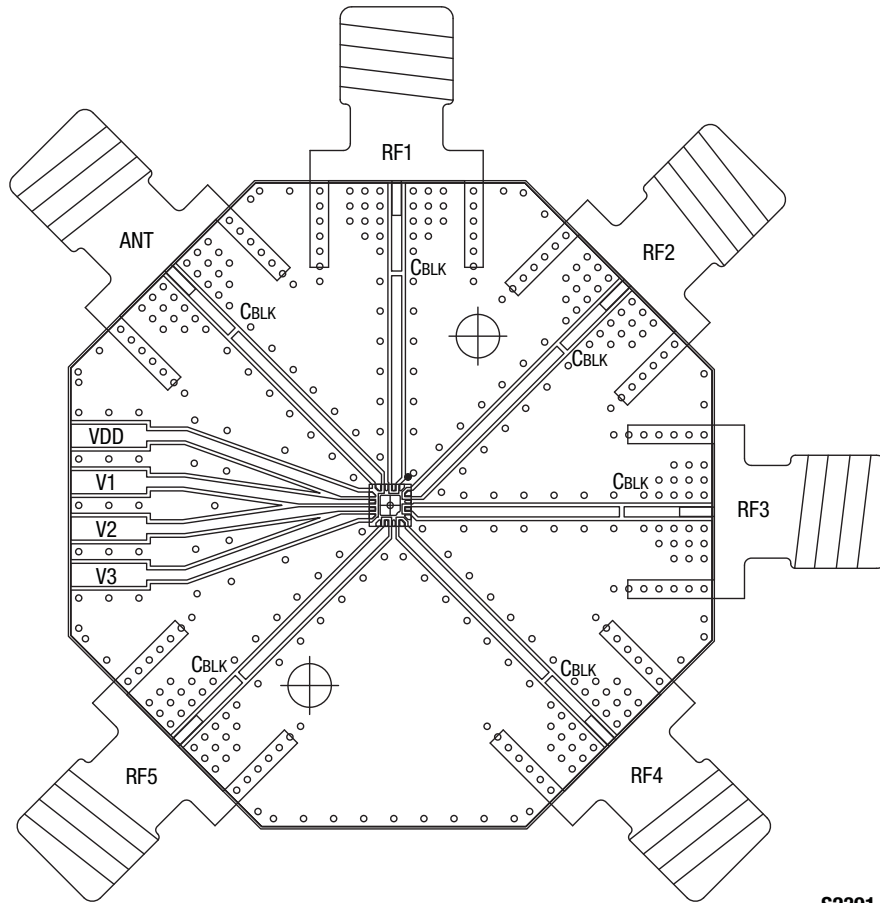

S2391

Figure 7. SKY13358-388LF Evaluation Board Assembly Diagram

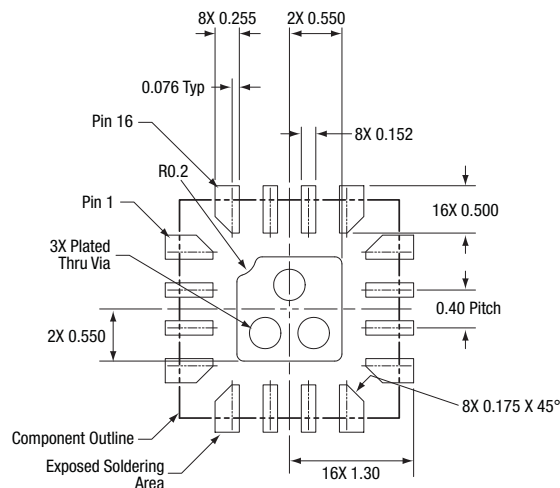

All measurements in millimeters

S2309

Figure 8. SKY13358-388LF PCB Layout Footprint (Top View)

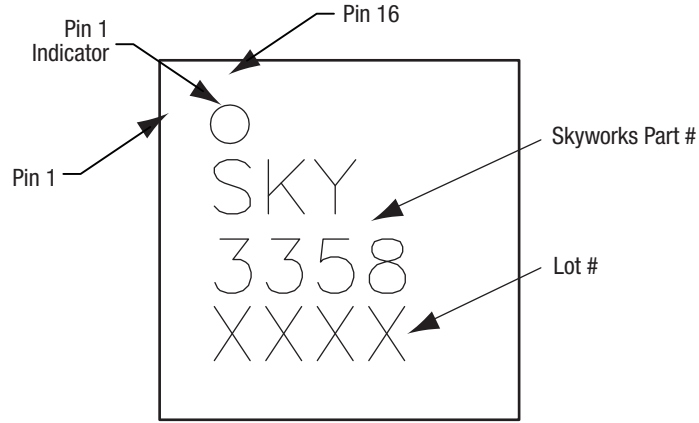
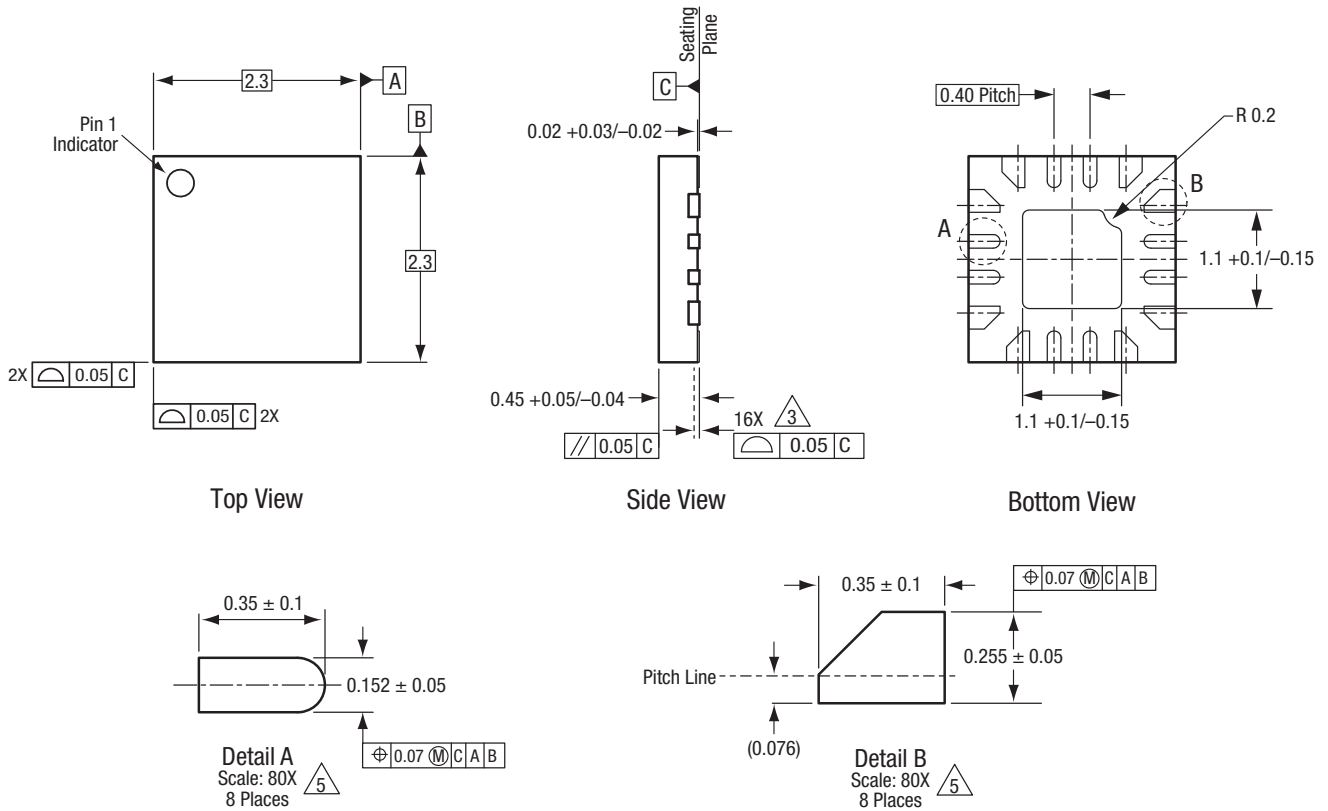

Figure 9. Typical Part Markings (Top View)



All measurements are in millimeters

Dimensioning and tolerancing according to ASME Y14.5M-1994

S2307

Figure 10. SKY13358-388LF 16-Pin QFN Package Dimensions

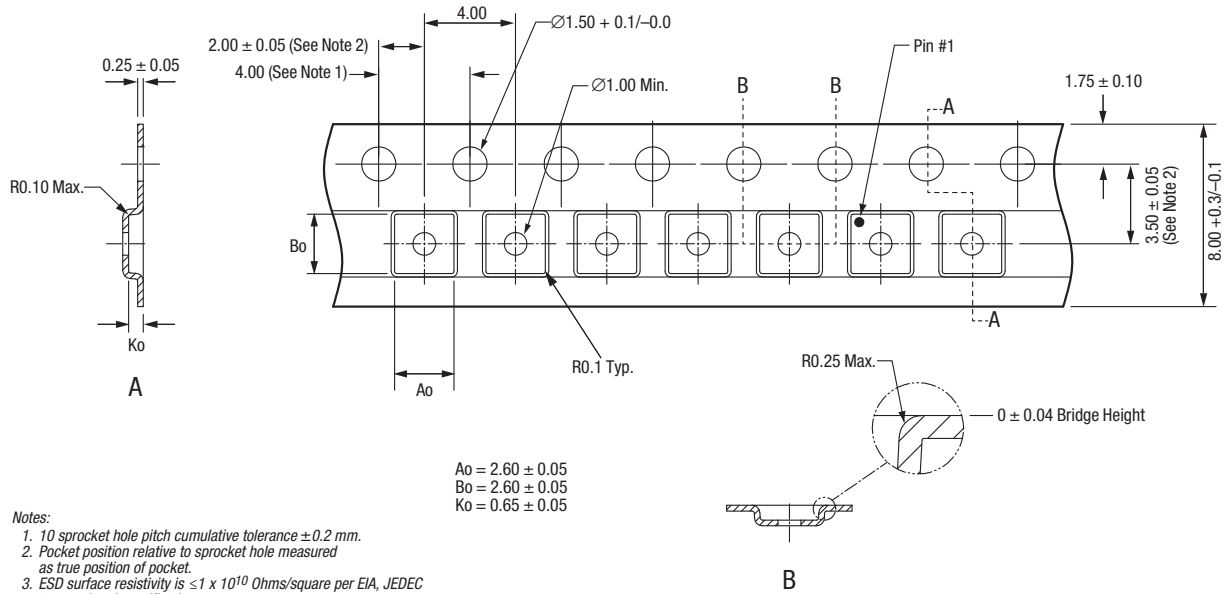

- Notes:
1. 10 sprocket hole pitch cumulative tolerance ± 0.2 mm.
 2. Pocket position relative to sprocket hole measured as true position of pocket.
 3. ESD surface resistivity is $\leq 1 \times 10^{10}$ Ohms/square per EIA, JEDEC tape and reel specification.
 4. Carrier tape: black conductive polycarbonate.
 5. Cover tape material: transparent conductive material.
 6. A_o and B_o measured on plane 0.30 mm above the bottom of the pocket
 7. All measurements are in millimeters.

S2546

Figure 11. SKY13358-388LF Tape and Reel Dimensions

Ordering Information

Model Name	Manufacturing Part Number	Evaluation Board Part Number
SKY13358-388LF SP5T Switch	SKY13358-388LF	SKY13358-388LF-EVB

Copyright © 2011-2013 Skyworks Solutions, Inc. All Rights Reserved.

Information in this document is provided in connection with Skyworks Solutions, Inc. (“Skyworks”) products or services. These materials, including the information contained herein, are provided by Skyworks as a service to its customers and may be used for informational purposes only by the customer. Skyworks assumes no responsibility for errors or omissions in these materials or the information contained herein. Skyworks may change its documentation, products, services, specifications or product descriptions at any time, without notice. Skyworks makes no commitment to update the materials or information and shall have no responsibility whatsoever for conflicts, incompatibilities, or other difficulties arising from any future changes.

No license, whether express, implied, by estoppel or otherwise, is granted to any intellectual property rights by this document. Skyworks assumes no liability for any materials, products or information provided hereunder, including the sale, distribution, reproduction or use of Skyworks products, information or materials, except as may be provided in Skyworks Terms and Conditions of Sale.

THE MATERIALS, PRODUCTS AND INFORMATION ARE PROVIDED “AS IS” WITHOUT WARRANTY OF ANY KIND, WHETHER EXPRESS, IMPLIED, STATUTORY, OR OTHERWISE, INCLUDING FITNESS FOR A PARTICULAR PURPOSE OR USE, MERCHANTABILITY, PERFORMANCE, QUALITY OR NON-INFRINGEMENT OF ANY INTELLECTUAL PROPERTY RIGHT; ALL SUCH WARRANTIES ARE HEREBY EXPRESSLY DISCLAIMED. SKYWORKS DOES NOT WARRANT THE ACCURACY OR COMPLETENESS OF THE INFORMATION, TEXT, GRAPHICS OR OTHER ITEMS CONTAINED WITHIN THESE MATERIALS. SKYWORKS SHALL NOT BE LIABLE FOR ANY DAMAGES, INCLUDING BUT NOT LIMITED TO ANY SPECIAL, INDIRECT, INCIDENTAL, STATUTORY, OR CONSEQUENTIAL DAMAGES, INCLUDING WITHOUT LIMITATION, LOST REVENUES OR LOST PROFITS THAT MAY RESULT FROM THE USE OF THE MATERIALS OR INFORMATION, WHETHER OR NOT THE RECIPIENT OF MATERIALS HAS BEEN ADVISED OF THE POSSIBILITY OF SUCH DAMAGE.



Skyworks products are not intended for use in medical, lifesaving or life-sustaining applications, or other equipment in which the failure of the Skyworks products could lead to personal injury, death, physical or environmental damage. Skyworks customers using or selling Skyworks products for use in such applications do so at their own risk and agree to fully indemnify Skyworks for any damages resulting from such improper use or sale.

Customers are responsible for their products and applications using Skyworks products, which may deviate from published specifications as a result of design defects, errors, or operation of products outside of published parameters or design specifications. Customers should include design and operating safeguards to minimize these and other risks. Skyworks assumes no liability for applications assistance, customer product design, or damage to any equipment resulting from the use of Skyworks products outside of stated published specifications or parameters.

Skyworks, the Skyworks symbol, and “Breakthrough Simplicity” are trademarks or registered trademarks of Skyworks Solutions, Inc., in the United States and other countries. Third-party brands and names are for identification purposes only, and are the property of their respective owners. Additional information, including relevant terms and conditions, posted at www.skyworksinc.com, are incorporated by reference.

Looking for pricing, stock, or lifecycle information?

Click below to explore more details on WIN SOURCE:

-  [View SKY13358-388LF on WIN SOURCE](#)
-  [Skyworks Solutions Inc. Information](#)

Optimize Your Supply Chain with WIN SOURCE Solutions

-  Global Sourcing Solution
-  Obsolete Management
-  Cost Control Management
-  Shortage Management
-  Alternative Solution
-  Excess Inventory Management