

Features

- Near-Zero propagation delay
- 5-ohm switches connect inputs to outputs
- Fast Switching Speed: 4.5ns max.
- Ultra-low quiescent power (0.1µA typical)
 - Ideally suited for notebook applications
- Packaging (Pb-free & Green available):
 - 24-pin 150-mil wide plastic QSOP (Q)
 - 24-pin 173-mil wide plastic TSSOP (L)

Description

Pericom Semiconductor's PI3B3384 is a 3.3 Volt, 10-bit, 2-port bus switches designed with a low On-Resistance allowing inputs to be connected directly to outputs. The bus switch creates no additional propagational delay or additional ground bounce noise. Switches are turned ON by the Bus Enable (\overline{BE}) input signal. Two bus enable signals are provided, one for each of the upper and lower five bits of the two 10-bit buses.

Block Diagram

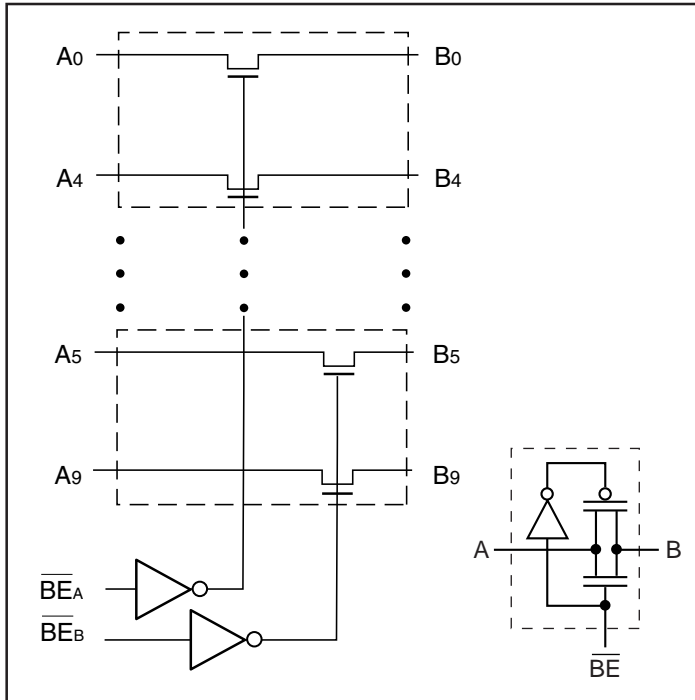

Pin Configuration

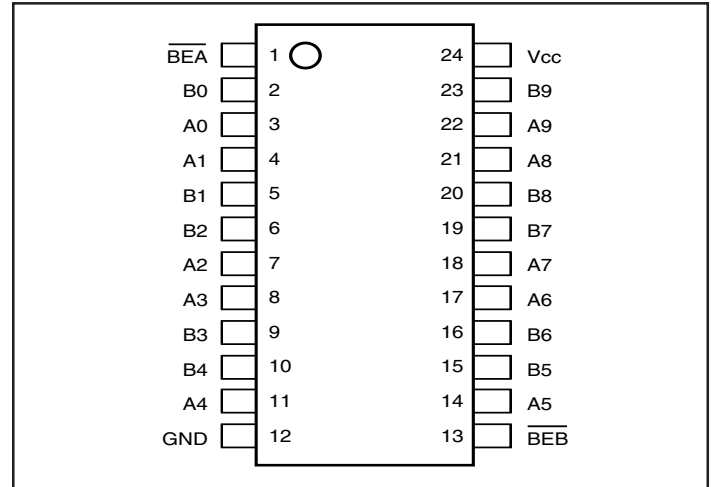

Truth Table⁽¹⁾

Function	\overline{BEA}	\overline{BEB}	B0-B4	B5-B9
Disconnect	H	H	Hi-Z	Hi-Z
Connect	L	H	A0-A4	Hi-Z
Connect	H	L	Hi-Z	A5-A9
Connect	L	L	A0-A4	A5-A9

Notes:

1. H = High Voltage Level
X = Don't Care
L = Low Voltage Level
Hi-Z = High Impedance

Pin Description

Pin Name	Description
\overline{BEA} , \overline{BEB}	Bus Enable Inputs (Active LOW)
A0-A9	Bus A
B0-A9	Bus B
GND	Ground
VCC	Power

Maximum Ratings

(Above which the useful life may be impaired. For user guidelines, not tested.)

Storage Temperature	-65°C to +150°C
Ambient Temperature with Power Applied	-40°C to +85°C
Supply Voltage to Ground Potential	-0.5V to +4.6V
DC Input Voltage	-0.5V to +4.6V
DC Output Current	120mA
Power Dissipation	0.5W

Note:

Stresses greater than those listed under MAXIMUM RATINGS may cause permanent damage to the device. This is a stress rating only and functional operation of the device at these or any other conditions above those indicated in the operational sections of this specification is not implied. Exposure to absolute maximum rating conditions for extended periods may affect reliability.

DC Electrical Characteristics (Over the Operating Range, $T_A = -40^\circ\text{C}$ to $+85^\circ\text{C}$, $V_{CC} = 3.3\text{V} \pm 10\%$)

Parameters	Description	Test Conditions ⁽¹⁾	Min.	Typ ⁽²⁾	Max.	Units
V_{IH}	Input HIGH Voltage	Guaranteed Logic HIGH Level	2.0			V
V_{IL}	Input LOW Voltage	Guaranteed Logic LOW Level	-0.5		0.8	V
I_{IH}	Input HIGH Current	$V_{CC} = \text{Max.}, V_{IN} = V_{CC}$			± 1	μA
I_{IL}	Input LOW Current	$V_{CC} = \text{Max.}, V_{IN} = \text{GND}$			± 1	μA
I_{OFF}	Off Current	$V_{CC} = 0, V_{OUT} = 3 \text{ TO } 3.3\text{V}$			10	μA
V_{IK}	Clamp Diode Voltage	$V_{CC} = \text{Min.}, I_{IN} = -18\text{mA}$		-1.2	V	
R_{ON}	Switch On Resistance ⁽³⁾	$V_{CC} = \text{Min.}, V_{IN} = 0.0\text{V}, I_{ON} = 48\text{mA or } 64\text{mA}$	PI3B3384	5	8	Ω
		$V_{CC} = \text{Min.}, V_{IN} = 2.4\text{V}, I_{ON} = 15\text{mA}$	PI3B3384	10	17	Ω

Notes:

- For Max. or Min. conditions, use appropriate value specified under Electrical Characteristics for the applicable device type.
- Typical values are at $V_{CC} = 3.3\text{V}$, $T_A = 25^\circ\text{C}$ ambient and maximum loading.
- Measured by the voltage drop between A and B pin at indicated current through the switch. ON resistance is determined by the lower of the voltages on the two (A,B) pins.

Capacitance ($T_A = 25^\circ\text{C}$, $f = 1\text{ MHz}$)

Parameters ⁽¹⁾	Description	Test Conditions	Typ.	Units
C_{IN}	Input Capacitance	$V_{IN} = 0\text{V}$	3.0	pF
C_{OFF}	A/B Capacitance, Switch Off	$V_{IN} = 0\text{V}$	8.0	pF
C_{ON}	A/B Capacitance, Switch On	$V_{IN} = 0\text{V}$	16.0	pF

Notes:

- This parameter is determined by device characterization but is not production tested.

Power Supply Characteristics

Parameters	Description	Test Conditions ⁽¹⁾	Min.	Typ ⁽²⁾	Max.	Units
I _{CC}	Quiescent Power Supply Current	V _{CC} =Max., V _{IN} =GND or V _{CC}		0.1	3	μA
ΔI _{CC}	Supply Current per Input @ TTL HIGH	V _{CC} =Max., V _{IN} =3.0V ⁽³⁾			750	μA

Notes:

1. For Max. or Min. conditions, use appropriate value specified under Electrical Characteristics for the applicable device.
2. Typical values are at V_{CC} = 3.3V, +25°C ambient.
3. Per TTL driven input (control inputs only); A and B pins do not contribute to I_{CC}.

PI3B3384 Switching Characteristics Over Operating Range

Parameters	Description	Conditions ⁽¹⁾	Com.		Units
			Min.	Max.	
t _{PLH} t _{PHL}	Propagation Delay ^(2,3) Ax to Bx, Bx to Ax	C _L = 50pF R _L = 500Ω		0.25	ns
t _{PZH} t _{PZL}	Bus Enable Time BEx to Ax or Bx	C _L = 50pF R _L = 500Ω R _L = 500Ω	1.0	4.0	
t _{PHZ} t _{PLZ}	Bus Disable Time BEx to Ax or Bx		1.0	3.5	

Notes:

1. See test circuit and waveforms.
2. This parameter is guaranteed but not tested on Propagation Delays.
3. The bus switch contributes no propagational delay other than the RC delay of the ON resistance of the switch and the load capacitance. The time constant for the switch alone is of the order of 0.25ns for 50pF load. Since this time constant is much smaller than the rise/fall times of typical driving signals, it adds very little propagational delay to the system. Propagational delay of the bus switch when used in a system is determined by the driving circuit on the driving side of the switch and its interaction with the load on the driven side.

Packaging Mechanical: 24-pin QSOP (Q)

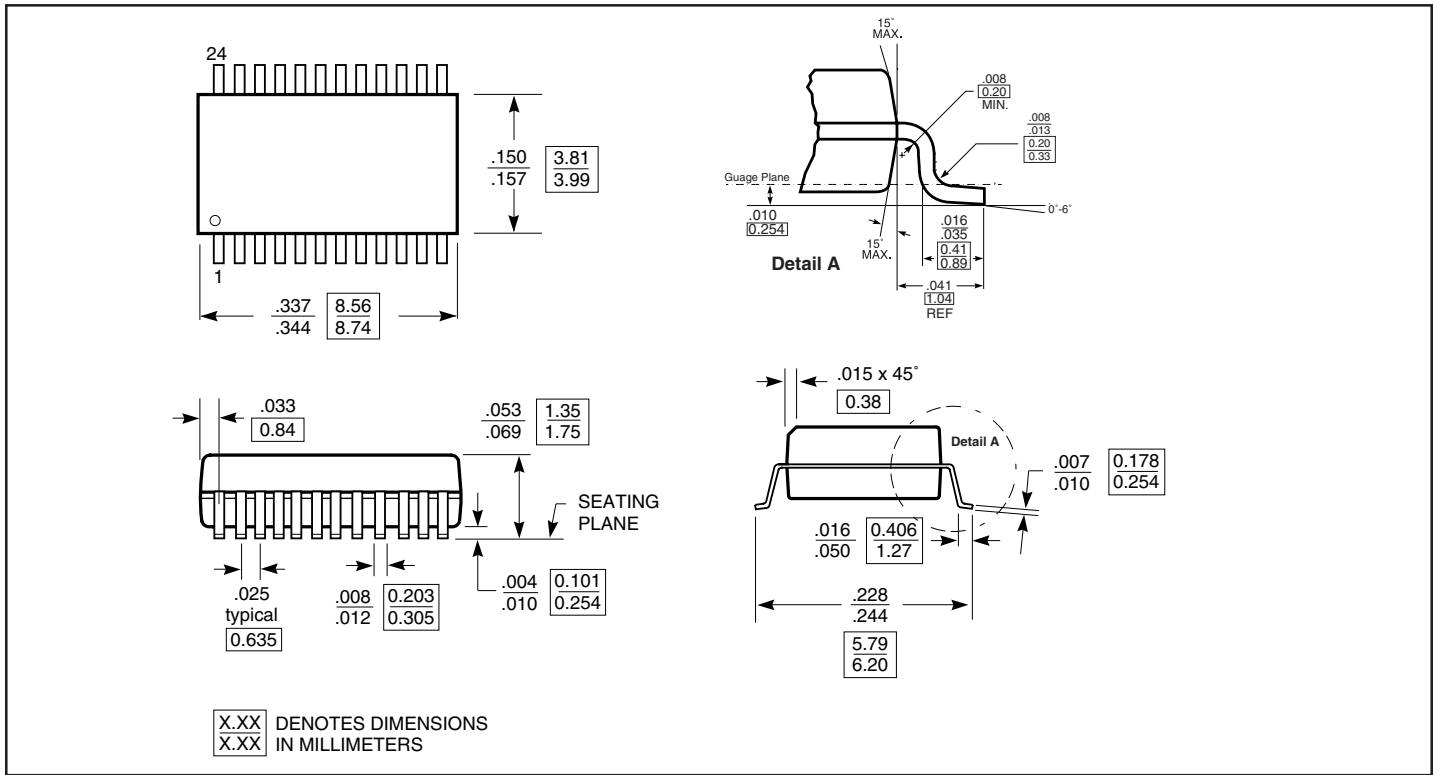

Packaging Mechanical: 24-pin TSSOP (L)

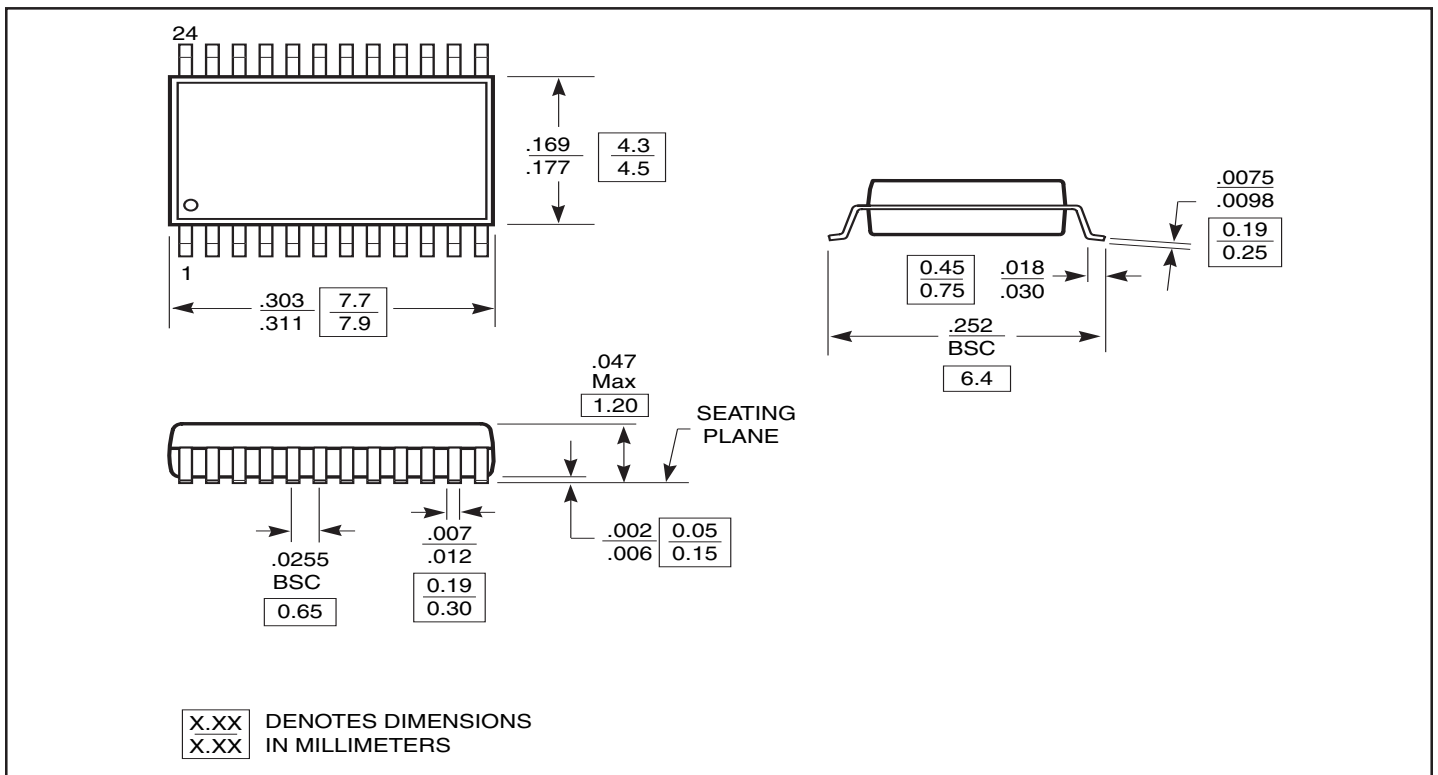

Applications Information

Logic Inputs

The logic control inputs can be driven up to +3.6V regardless of the supply voltage. For example, given a +3.3V supply, IN may be driven low to 0V and high to 3.6V. Driving IN Rail-to-Rail® minimizes power consumption.

Power-Supply Sequencing and Hot-Plug Information

Proper power-supply sequencing is recommended for all CMOS devices. Always apply V_{CC} and GND before applying signals to input/output or control pins.

Rail-to-Rail is a registered trademark of Nippon Motorola, Ltd.

Ordering Information

Ordering Code	Package Code	Package Type
PI3B3384Q	Q	24-pin QSOP
PI3B3384QE	Q	Pb-free & Green, 24-pin QSOP
PI3B3384L	L	24-pin TSSOP
PI3B3384LE	L	Pb-free & Green, 24-pin TSSOP

Notes:

- Thermal characteristics can be found on the company web site at www.pericom.com/packaging/
- E = Pb-free and Green
- Adding an X Suffix = Tape/Reel

Looking for pricing, stock, or lifecycle information?

Click below to explore more details on WIN SOURCE:

 [View PI3B3384QE on WIN SOURCE](#)

 [Diodes Incorporated](#) Information

Optimize Your Supply Chain with WIN SOURCE Solutions

-  Global Sourcing Solution
-  Obsolete Management
-  Cost Control Management
-  Shortage Management
-  Alternative Solution
-  Excess Inventory Management