

# RNA51957A, B

R03DS0010EJ0500

Rev.5.00

Jun 19, 2012

## Voltage Detecting, System Resetting IC Series

### Description

RNA51957A,B are semiconductor integrated circuits for resetting of all types of logic circuits such as CPUs, and has the feature of setting the detection voltage by adding external resistance.

They include a built-in delay circuit to provide the desired retardation time simply by adding an external capacitor.

They find extensive applications, including battery checking circuit, level detecting circuit and waveform shaping circuit.

### Features

- Few external parts
- Large delay time with a capacitor of small capacitance ( $t_d \approx 100$  ms, at  $0.33 \mu\text{F}$ )
- Low threshold operating voltage (Supply voltage to keep low-state at low supply voltage):  
0.6 V (Typ) at  $R_L = 22 \text{ k}\Omega$
- Wide supply voltage range: 2 V to 17 V
- Wide application range
- Ordering Information

Part Name	Package Type	Package Code	Package Abbreviation	Taping Abbreviation (Quantity)	Surface Treatment
RNA51957AFPH0	SOP-8 pin	PRSP0008DE-C	FP	H (2,500 pcs / Reel)	0 (Ni/Pd/Au)
RNA51957APT0	DIP-8 pin	PRDP0008AF-B	P	T (1,000 pcs / Box)	0 (Ni/Pd/Au)
RNA51957BFPH0	SOP-8 pin	PRSP0008DE-C	FP	H (2,500 pcs / Reel)	0 (Ni/Pd/Au)
RNA51957BPT0	DIP-8 pin	PRDP0008AF-B	P	T (1,000 pcs / Box)	0 (Ni/Pd/Au)

### Application

- Reset circuit of Pch, Nch, CMOS, microcomputer, CPU and MCU, Reset of logic circuit, Battery check circuit, switching circuit back-up voltage, level detecting circuit, waveform shaping circuit, delay waveform generating circuit, DC/DC converter, over voltage protection circuit

### Recommended Operating Condition

- Supply voltage range: 2 V to 17 V

Outline and Article Indication

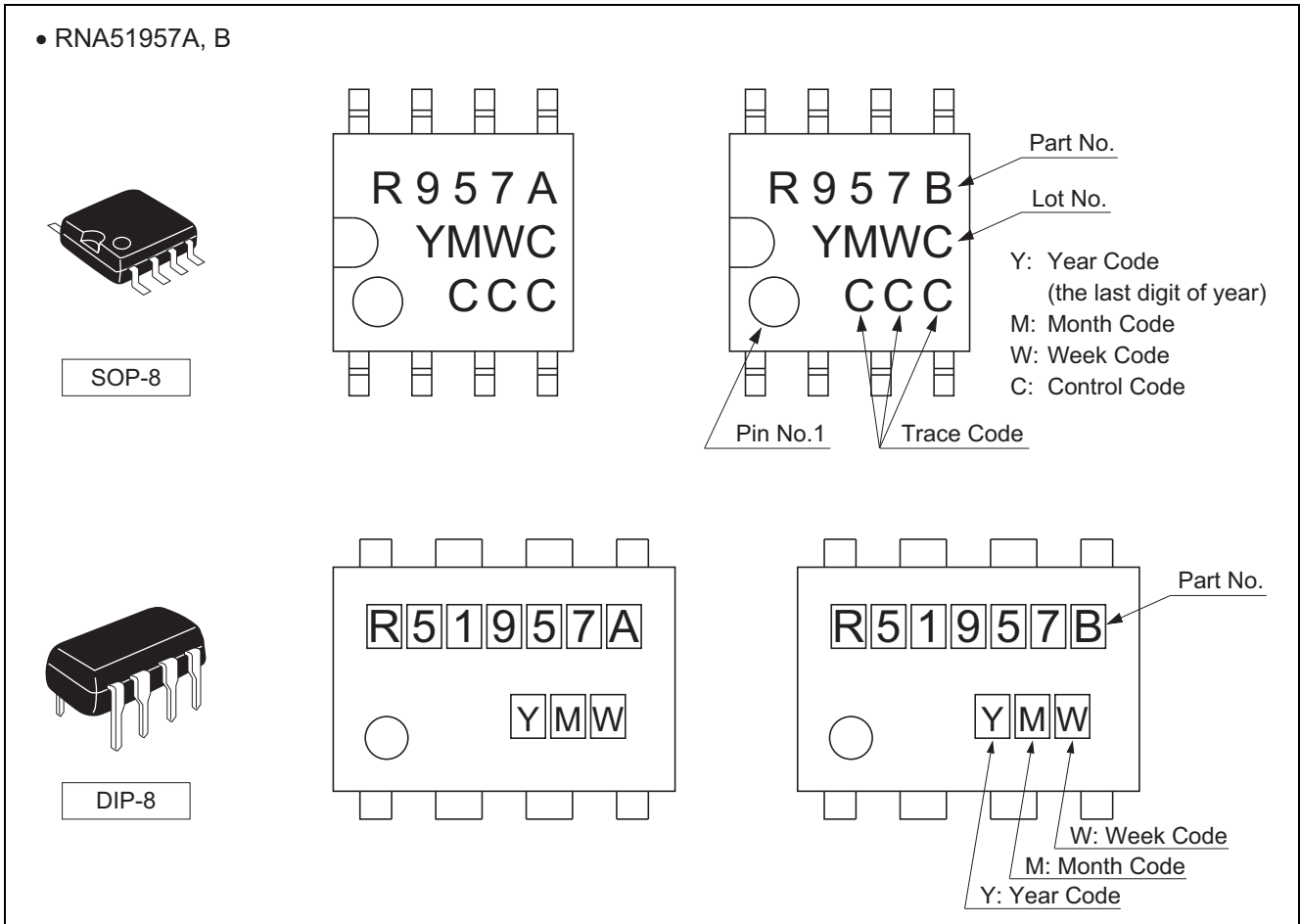

Pin Arrangement

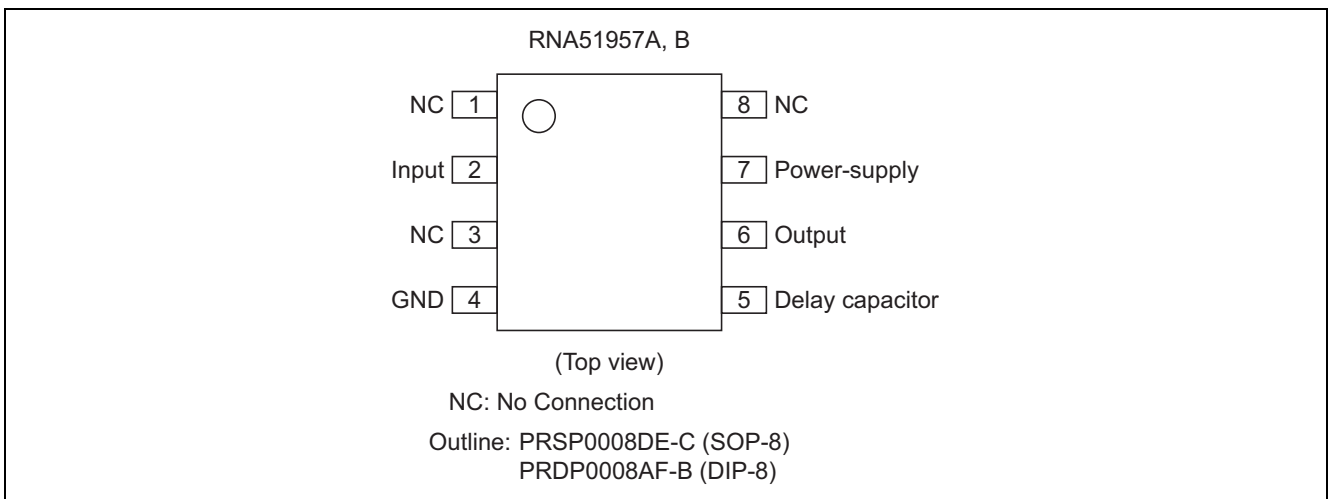

### Block Diagram

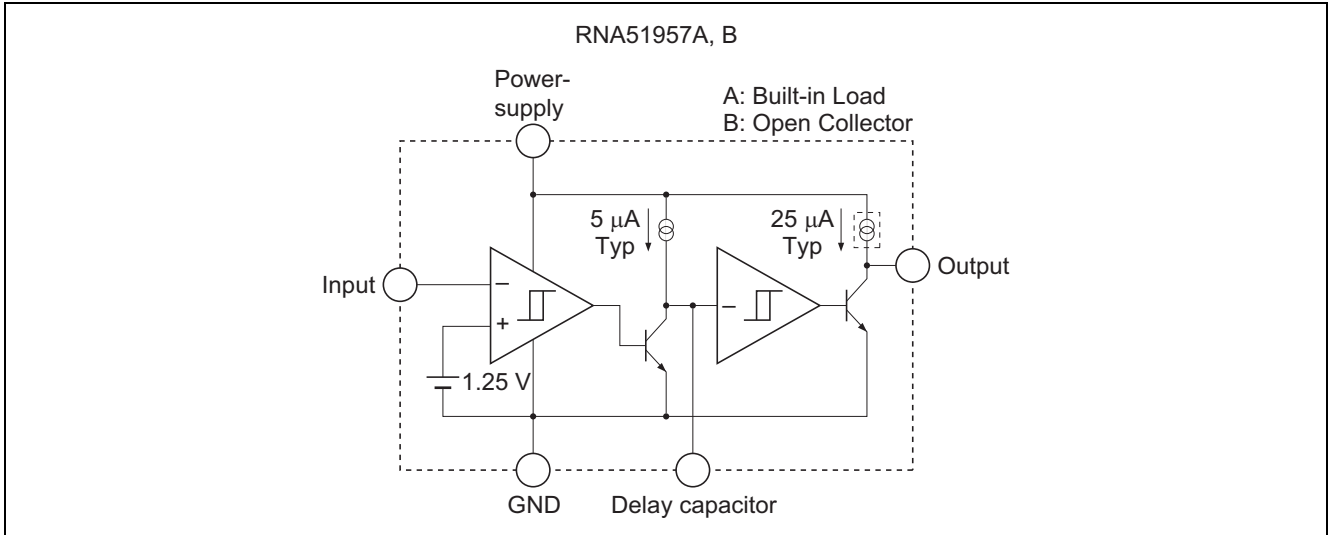

### Operating Waveform

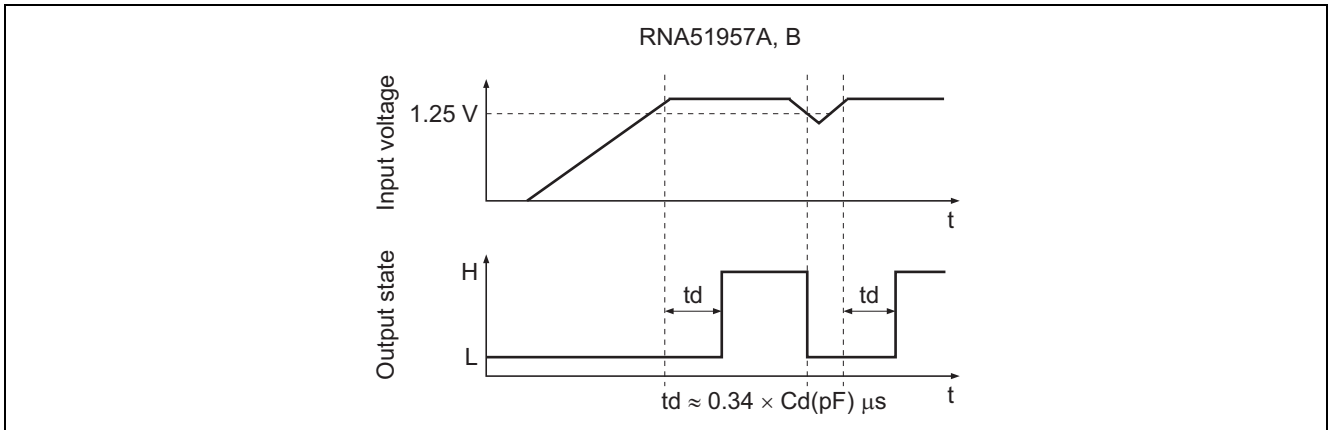

## Absolute Maximum Ratings

(Ta = 25°C, unless otherwise noted)

Item	Symbol	Ratings	Unit	Conditions	
Supply voltage	V <sub>CC</sub>	18	V		
Output sink current	I <sub>sink</sub>	6	mA		
Output voltage	V <sub>O</sub>	V <sub>CC</sub>	V	Type A (output with constant current load)	
		18		Type B (open collector output)	
Power dissipation	P <sub>d</sub>	400	mW	8-pin SOP (PRSP0008DE-C)	
		570		8-pin DIP (PRDP0008AF-B)	
Thermal derating	K <sub>θ</sub>	4.4	mW/°C	8-pin SOP (PRSP0008DE-C)	Refer to the thermal derating curve.
		8.3		8-pin DIP (PRDP0008AF-B)	
Operating temperature	T <sub>opr</sub>	-40 to +85	°C		
Storage temperature	T <sub>stg</sub>	-55 to +125	°C		
Input voltage range	V <sub>IN</sub>	-0.3 to V <sub>CC</sub>	V	V <sub>CC</sub> ≤ 7 V	
		-0.3 to +7		V <sub>CC</sub> > 7 V	

## Electrical Characteristics

(Ta = 25°C, unless otherwise noted)

- “L” reset type

Item	Symbol	Min	Typ	Max	Unit	Test Conditions	
Detecting voltage	V <sub>S</sub>	1.20	1.25	1.30	V		
Hysteresis voltage	ΔV <sub>S</sub>	9	15	23	mV	V <sub>CC</sub> = 5V	
Detecting voltage temperature coefficient	V <sub>S</sub> /ΔT	—	0.01	—	%/°C		
Supply voltage range	V <sub>CC</sub>	2	—	17	V		
Input voltage range	V <sub>in</sub>	-0.3	—	V <sub>CC</sub>	V	V <sub>CC</sub> ≤ 7V	
		-0.3	—	7.0		V <sub>CC</sub> > 7V	
Input current	I <sub>IN</sub>	—	100	500	nA	V <sub>IN</sub> = 1.25V	
Circuit current	I <sub>CC</sub>	—	390	590	μA	Type A, V <sub>CC</sub> = 5V	
		—	360	540		Type B, V <sub>CC</sub> = 5V	
Delay time	t <sub>pd</sub>	1.6	3.4	7.0	ms	C <sub>d</sub> = 0.01μF *	
Constant current	I <sub>pd</sub>	-8	-5	-3	μA	V <sub>CC</sub> = 5V	
Output saturation voltage	V <sub>sat</sub>	—	0.2	0.4	V	L reset type, V <sub>CC</sub> = 5V, V <sub>IN</sub> < 1.2V, I <sub>sink</sub> = 4mA	
Threshold operating voltage	V <sub>OPL</sub>	—	0.67	0.8	V	L reset type minimum supply voltage for IC operation	R <sub>L</sub> = 2.2kΩ, V <sub>sat</sub> ≤ 0.4V
		—	0.55	0.7			R <sub>L</sub> = 100kΩ, V <sub>sat</sub> ≤ 0.4V
Output leakage current	I <sub>OH</sub>	—	—	30	nA	Type B	
Output load current	I <sub>OC</sub>	-40	-25	-17	μA	Type A, V <sub>CC</sub> = 5V, V <sub>O</sub> = 1/2 × V <sub>CC</sub>	
Output high voltage	V <sub>OH</sub>	V <sub>CC</sub> -0.2	V <sub>CC</sub> -0.06	—	V	Type A	

Note: Please set the desired delay time by attaching capacitor of the range between 4700 pF and 10 μF.

Typical Characteristics

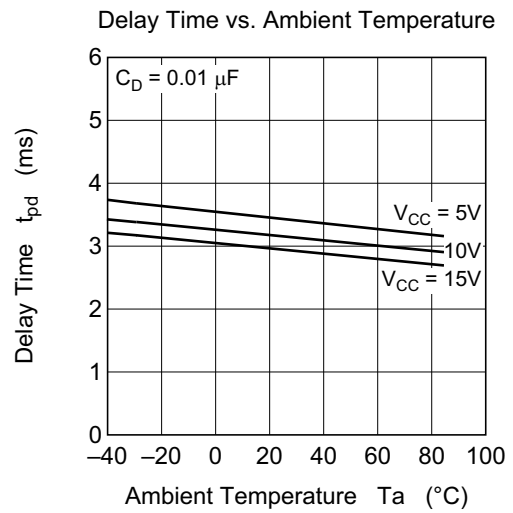
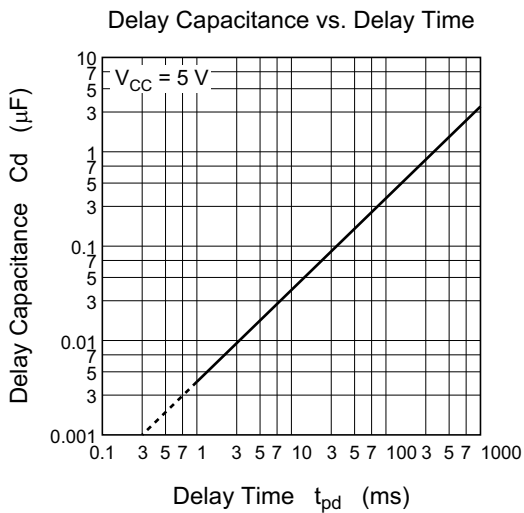
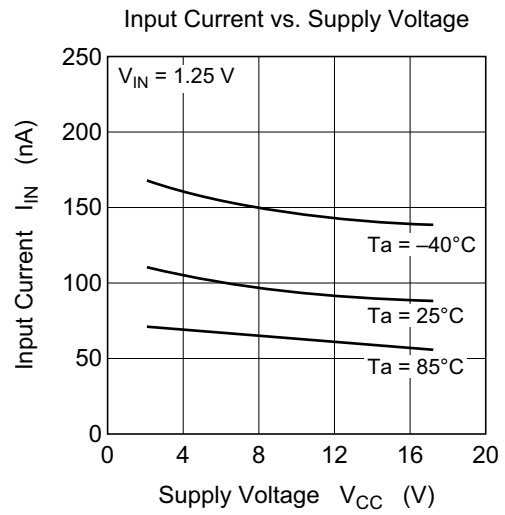
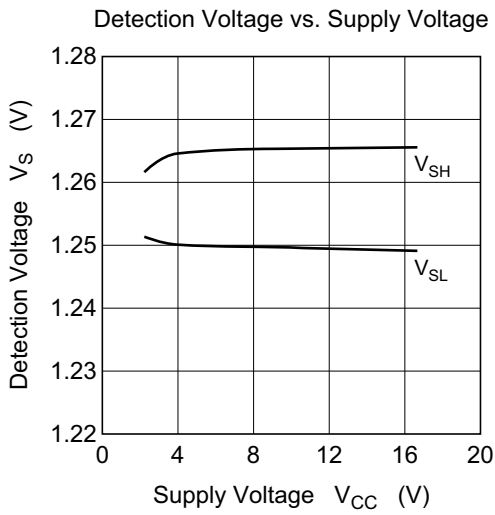
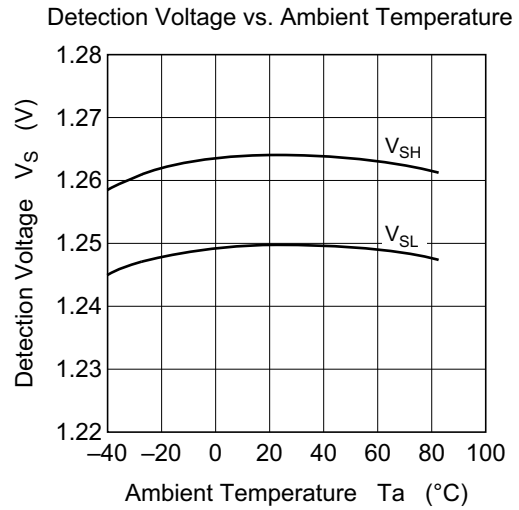
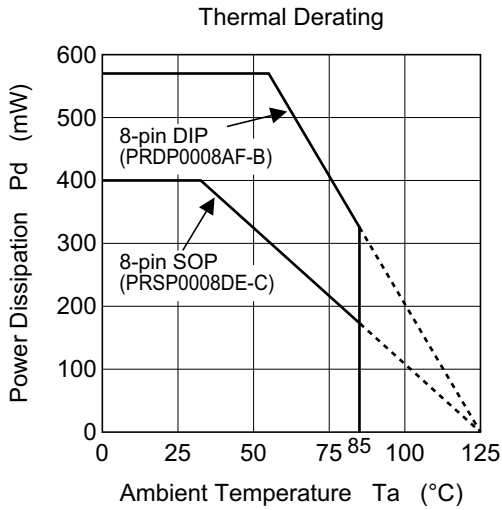

Constant Current at Cd pin vs. Ambient Temperature

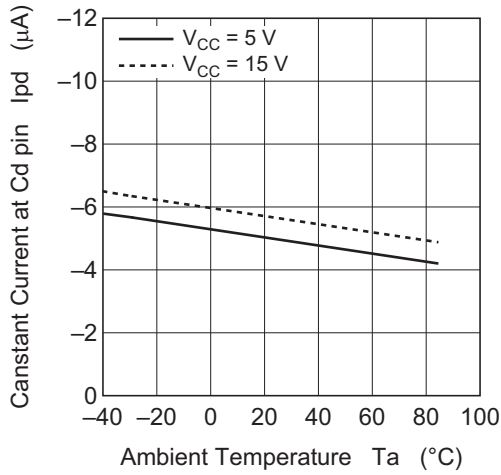

Threshold Operating Voltage

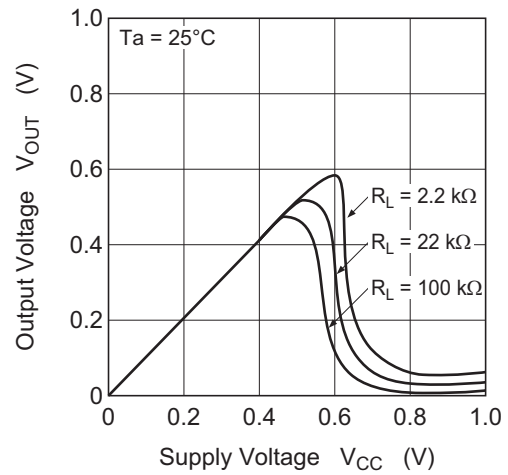

Output Saturation Voltage vs. Output Sink Current

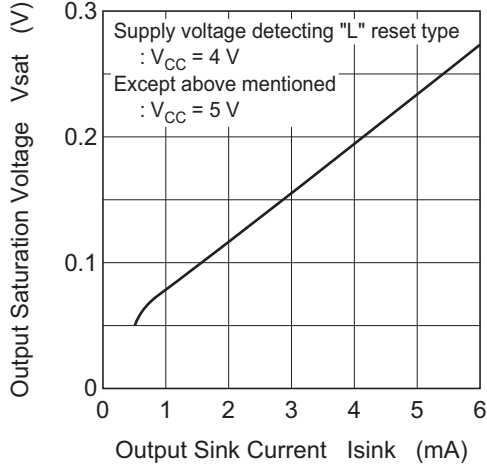

Output Load Current vs. Output Voltage (RNA51957A)

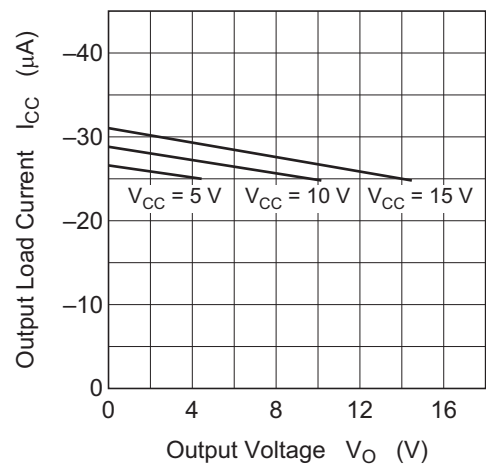

Circuit Current vs. Supply Voltage (RNA51957B)

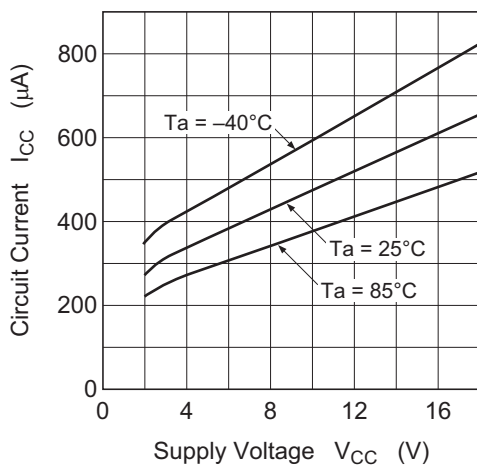

## Example of Application Circuit

### Reset Circuit of RNA51957

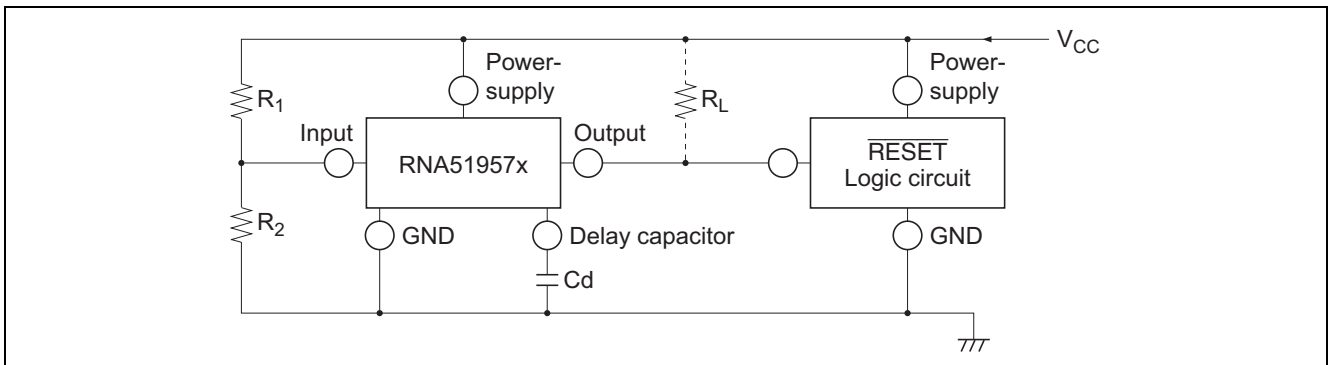

**Figure 1 Reset Circuit of RNA51957**

- Notes:
1. The detecting supply voltage is  $V_S \times (R_1 + R_2)/R_2$  (V) approximately.  $V_S = 1.25$  V (Typ)  
The detecting supply voltage can be set between 2 V and 15 V.
  2. The delay time is about  $0.34 \times C_d$  (pF)  $\mu$ s.
  3. If the RNA51957 and the logic circuit share a common power source, type A (built-in load type) can be used whether a pull-up resistor is included in the logic circuit or not.
  4. The logic circuit preferably should not have a pull-down resistor, but if one is present, add load resistor  $R_L$  to overcome the pull-down resistor.
  5. When a negative supply voltage is used, the supply voltage side of RNA51957 and the GND side are connected to negative supply voltage respectively.

### Case of Using Reset Signal except Supply Voltage in the RNA51957

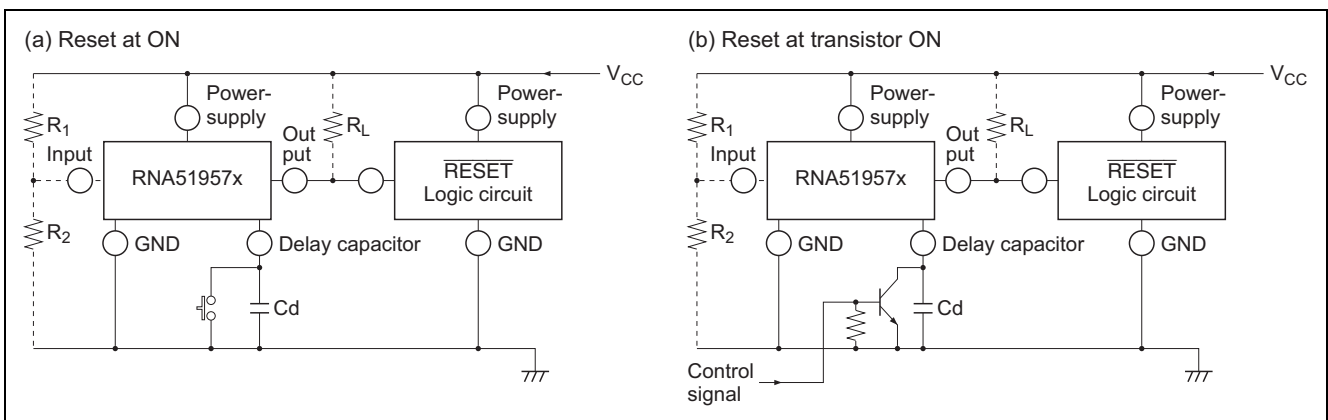

**Figure 2 Case of Using Reset Signal except Supply Voltage in the RNA51957**

**Delay Waveform Generating Circuit**

When RNA51957 are used, a waveform with a large delay time can generate only by adding a small capacitor.

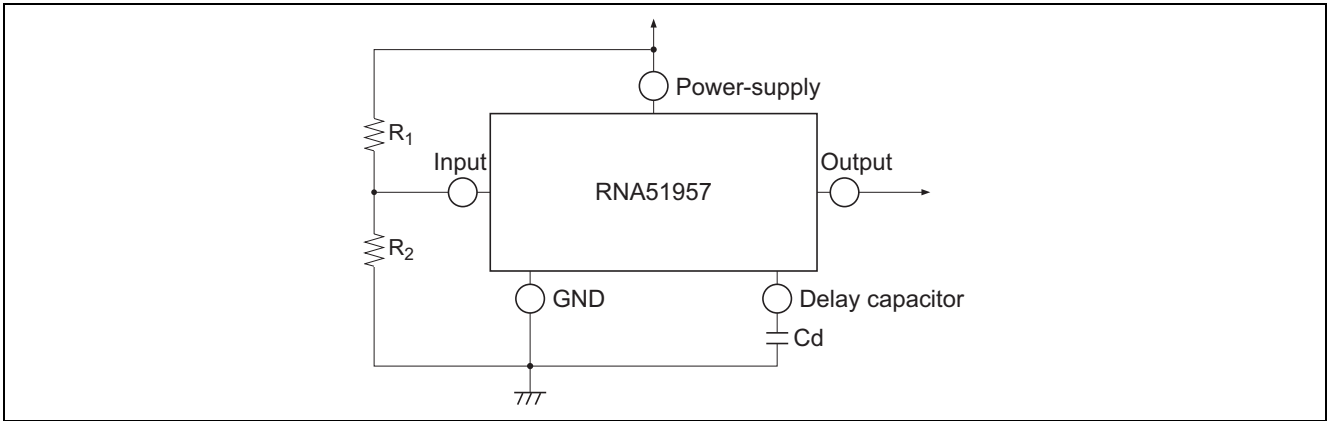

**Figure 3 Delay Waveform Generating Circuit**

**Operating Waveform**

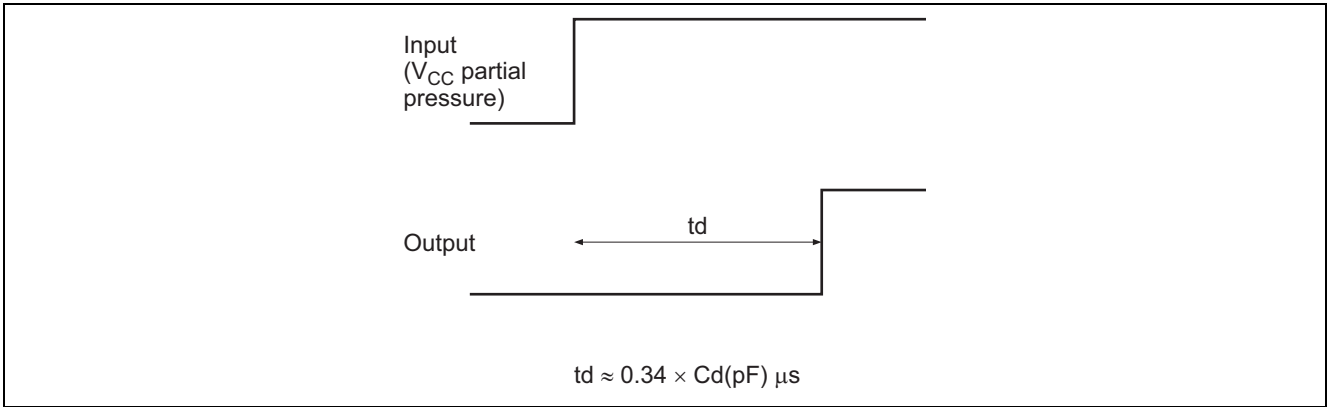

**Figure 4 Operating Waveform**

## Notice for use

### About the Power Supply Line

1. About bypass capacitor

Because the ripple and the spike of the high frequency noise and the low frequency are superimposed to the power supply line, it is necessary to remove these.

Therefore, please install  $C_1$  and  $C_2$  for the low frequency and for the high frequency between the power supply line and the GND line as shown in following figure 5.

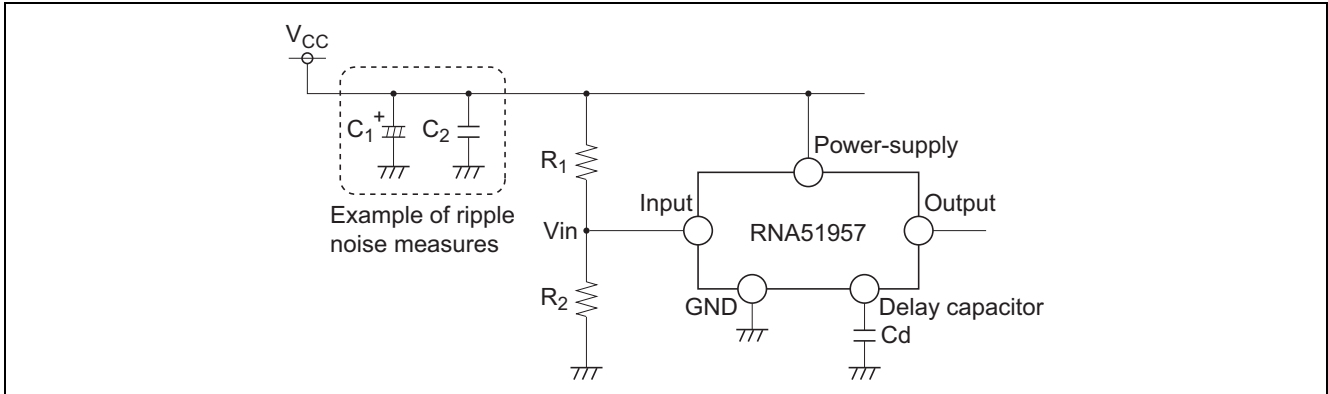

**Figure 5 Example of Ripple Noise Measures**

2. The sequence of voltage impression

Please do not impress the voltages to the input terminals earlier than the power supply terminal. Moreover, please do not open the power supply terminal with the voltage impressed to the input terminal.

(The setting of the bias of an internal circuit collapses, and a parasitic element might operate.)

### About the Input Terminal

1. Setting range of input voltage

The following voltage is recommended to be input to the input terminal (pin 2).

$$\text{about } 0.8 \text{ (V)} < V_{in} < V_{CC} - 0.3 \text{ (V)} \dots \text{ at } V_{CC} \leq 7 \text{ V}$$

$$\text{about } 0.8 \text{ (V)} < V_{in} < 6.7 \text{ (V)} \dots \text{ at } V_{CC} > 7 \text{ V}$$

2. About using input terminal

Please do an enough verification to the transition characteristic etc. of the power supply when using independent power supply to input terminal (pin 2).

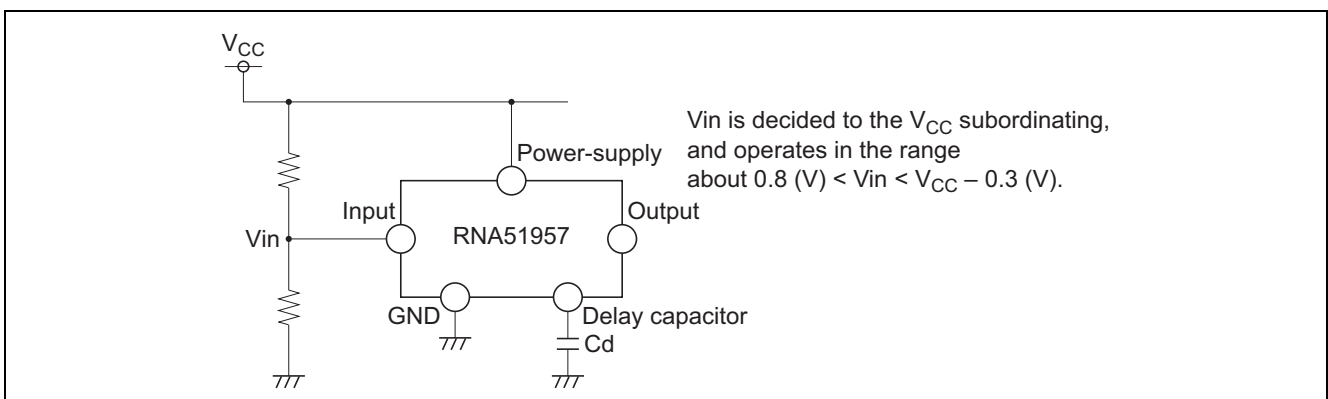

**Figure 6 Recommended Example**

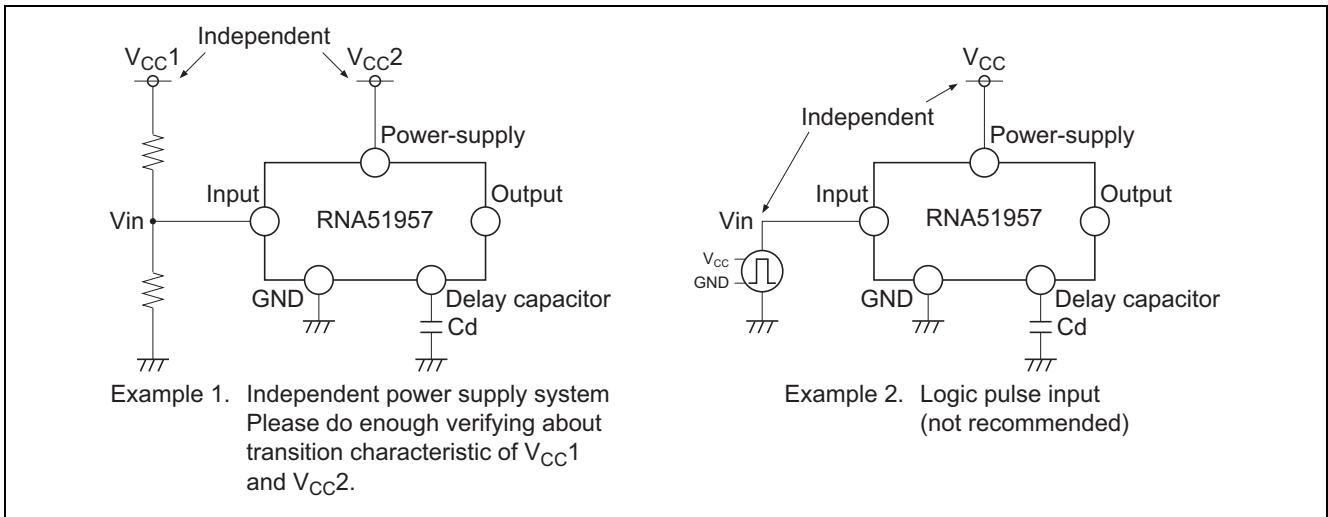

Figure 7

3. Calculation of detecting voltage

Detecting voltage V<sub>S</sub> can be calculated by the following expression.

However, the error margin is caused in the detecting voltage because input current I<sub>in</sub> (standard 100 nA) exists if it sets too big resistance.

Please set the constant to disregard this error margin.

$$V_S = 1.25 \times \left( \frac{R_1 + R_2}{R_2} \right) + \frac{I_{in} \times R_1}{\text{error margin}}$$

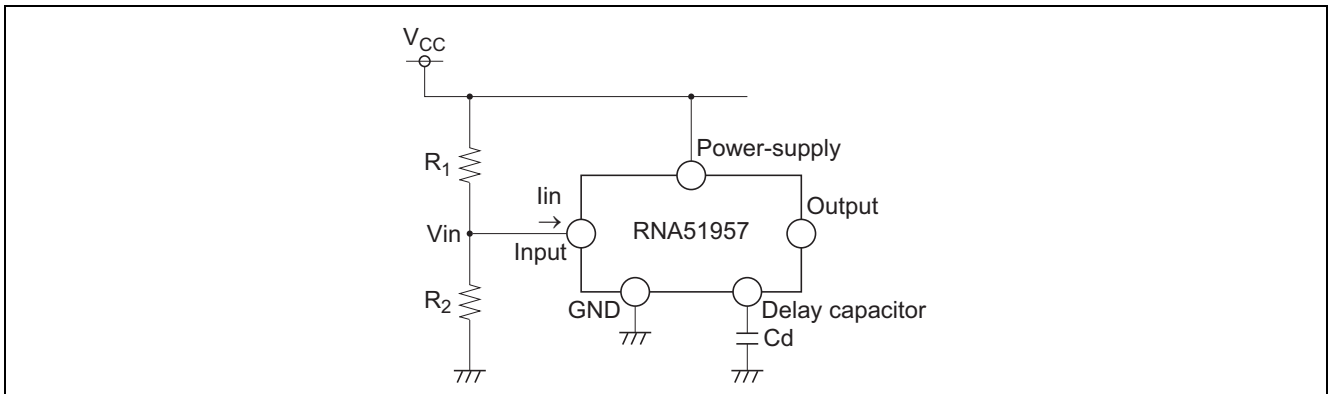

Figure 8 Influence of Input Current

4. About the voltage input outside ratings

Please do not input the voltage outside ratings to the input terminal.

An internal protection diode becomes order bias, and a large current flows.

**Setting of Delay Capacity**

Please use capacitor Cd for the delay within the range of 10 μF or less.

When a value that is bigger than this is set, the problem such as following (1), (2), and (3) becomes remarkable.

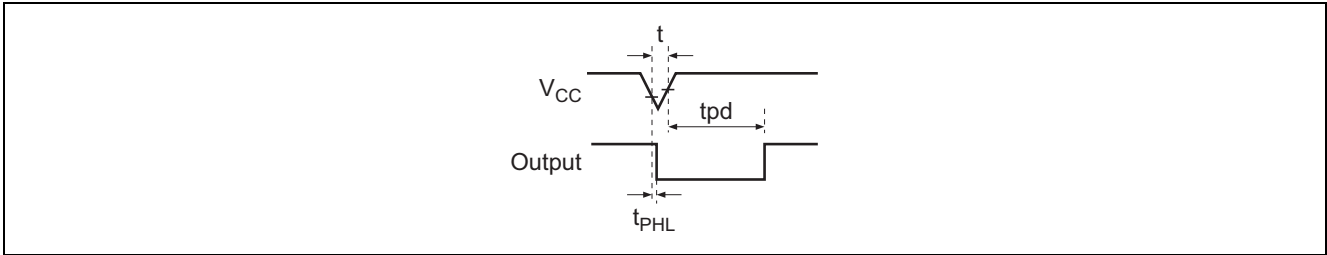

**Figure 9 Time Chart at Momentary Voltage-Decrease**

(1) The difference at delay time becomes remarkable.

A long delay setting of tens of seconds is fundamentally possible. However, when set delay time is lengthened, the range of the difference relatively grows, too. When a set value is assumed to be 'tpd', the difference occurs in the range from  $0.47 \times tpd$  to  $2.05 \times tpd$ . For instance, 34 seconds can be calculated at 100 μF. However, it is likely to vary within the ranges of 16-70 seconds.

(2) Difficulty to react to a momentary voltage decrease.

For example, the reaction time  $t_{PHL}$  is 10 μs when delay capacitor  $C_d = 0.1 \mu F$ .

The momentary voltage-decrease that is longer than such  $t_{PHL}$  are occurs, the detection becomes possible. When the delay capacitance is enlarged,  $t_{PHL}$  also becomes long. For instance, it becomes about 100 to 200 μs in case of circuit constant  $C1 = 100 \mu F$ .

(Characteristic graph 1 is used and extrapolation in case of  $C_d = 100 \mu F$ .)

Therefore, it doesn't react to momentary voltage-decrease that is shorter than this.

(3) Original delay time is not obtained.

When the momentary voltage-decrease time 't' is equivalent to  $t_{PHL}$ , the discharge becomes insufficient and the charge starts at that state. This phenomenon occurs at large capacitance. And, original delay time tpd is not obtained.

Please refer to characteristic graph 2. (Delay time versus input pulse width)

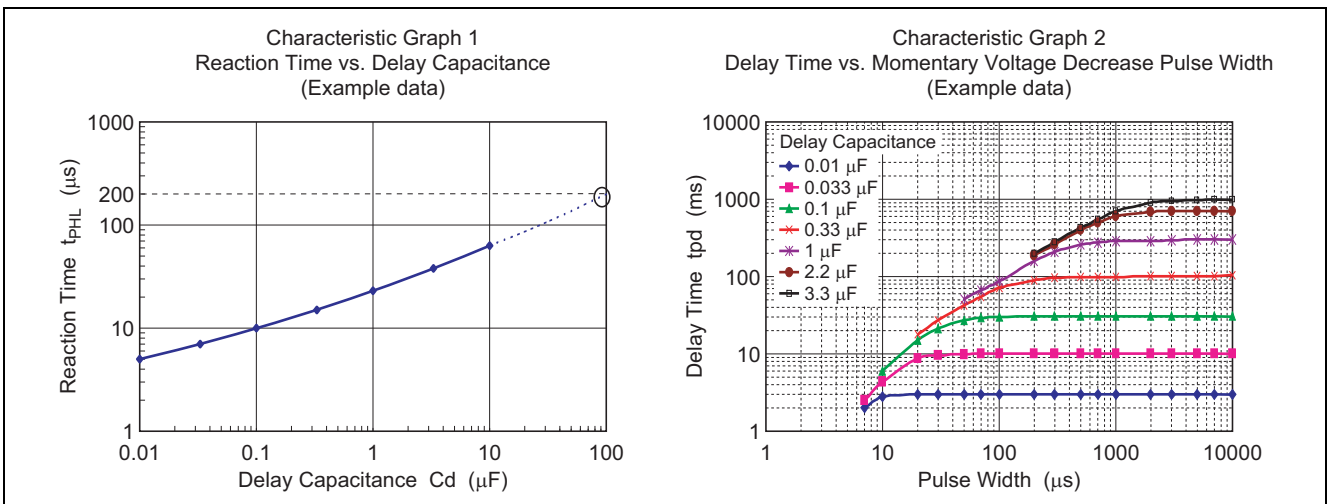

**Figure 10 Characteristic Graph**

### Setting of Output Load Resistance (RNA51957B)

High level output voltage can be set without depending on the power-supply voltage because the output terminal is an open collector type. However, please guard the following notes.

1. Please set it in value (2 V to 17 V) within the range of the power-supply voltage recommendation. Moreover, please never impress the voltage of maximum ratings 18 V or more even momentarily either.
2. Please set output load resistance (pull-up resistance)  $R_L$  so that the output current (output inflow current  $I_L$ ) at L level may become 4 mA or less. Moreover, please never exceed absolute maximum rating (6 mA).

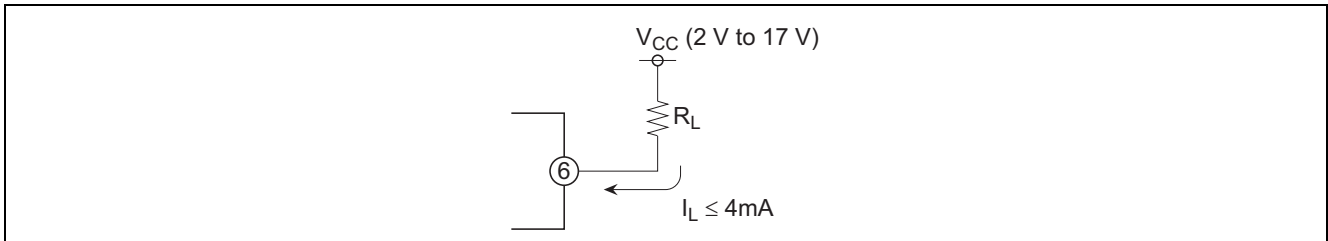
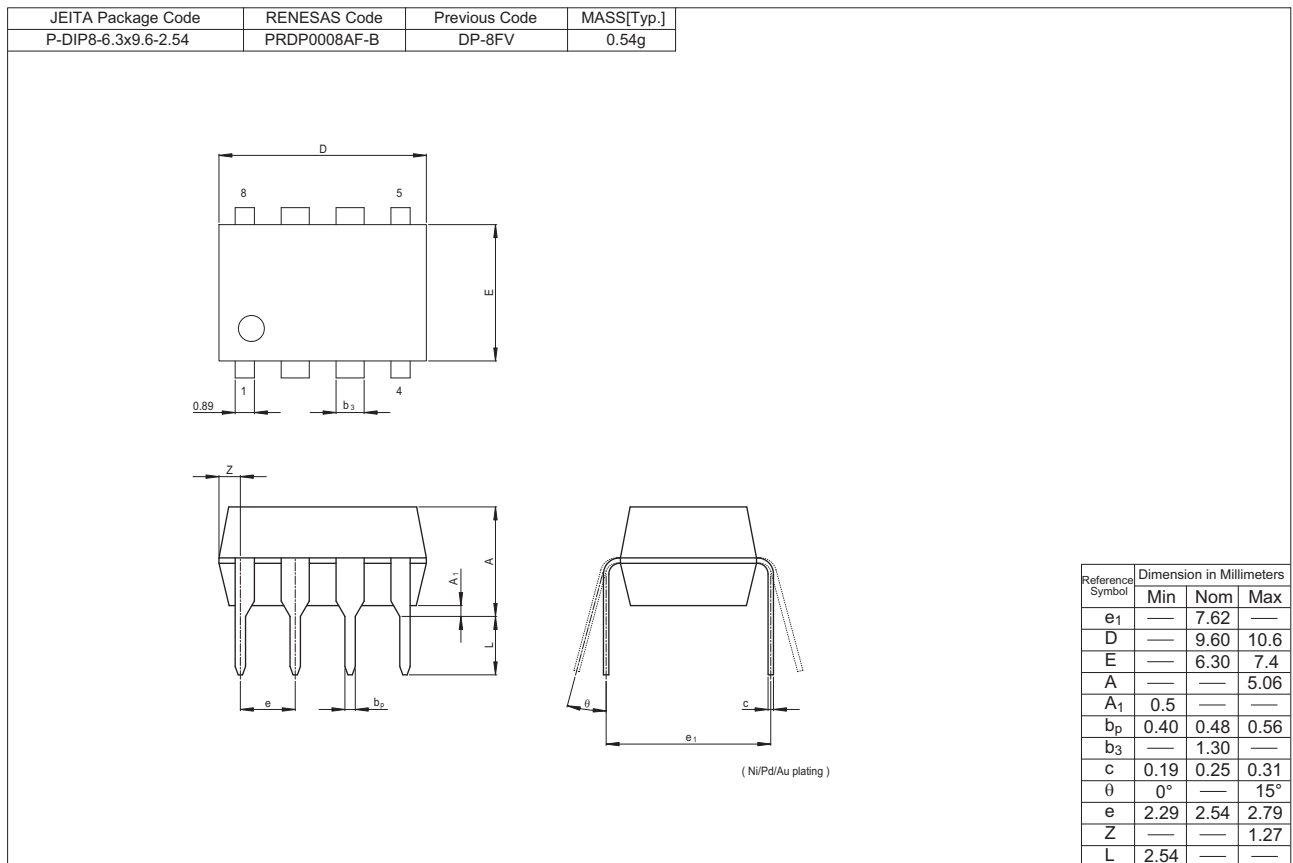
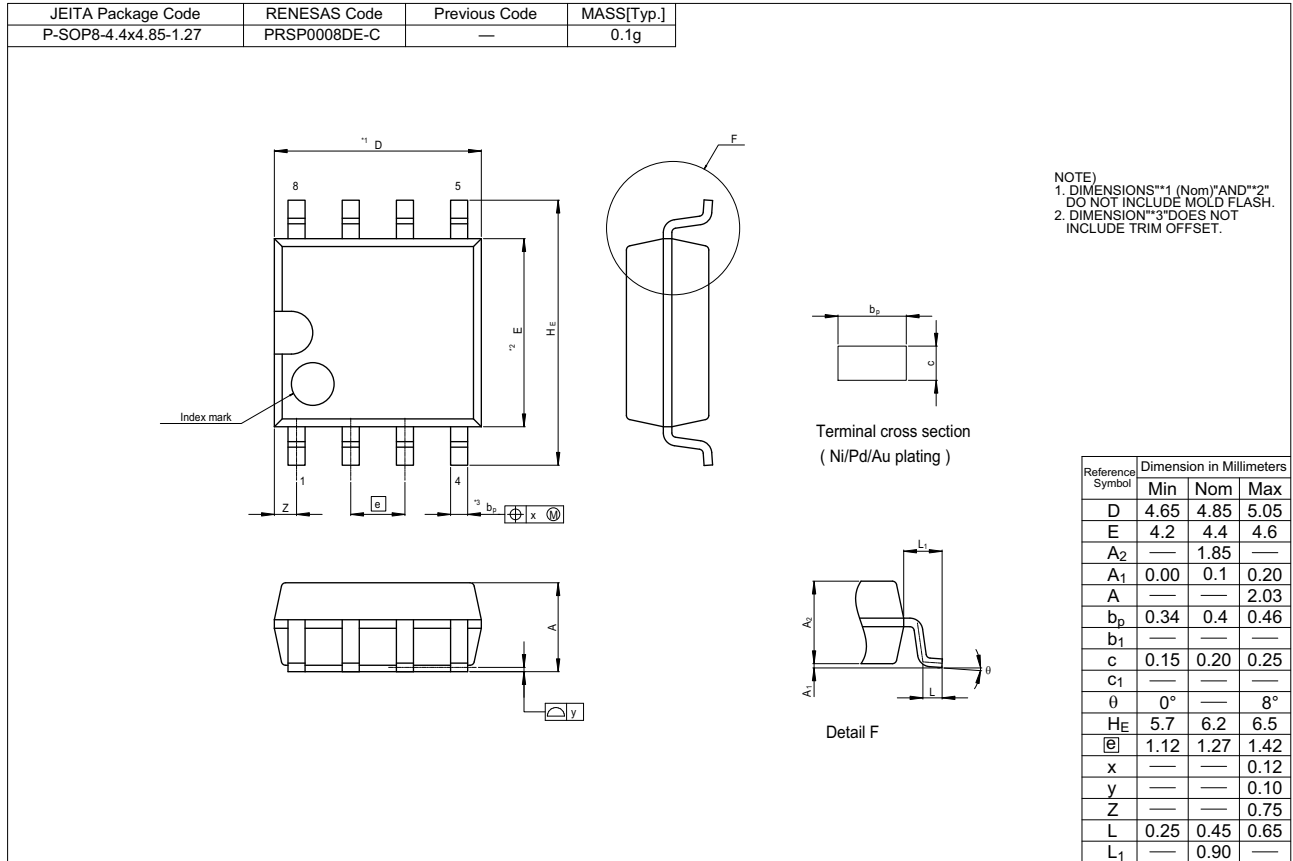

Figure 11 Output Load Resistance  $R_L$

### Others

1. Notes when IC is handled are published in our reliability handbook, and please refer it. The reliability handbook can be downloaded from our homepage (following URL).  
[http://www.renesas.com/products/common\\_info/reliability/index.jsp](http://www.renesas.com/products/common_info/reliability/index.jsp)
2. Additionally, please inquire of our company when there is an uncertain point on use.

### Package Dimensions



## Notice

1. Descriptions of circuits, software and other related information in this document are provided only to illustrate the operation of semiconductor products and application examples. You are fully responsible for the incorporation of these circuits, software, and information in the design of your equipment. Renesas Electronics assumes no responsibility for any losses incurred by you or third parties arising from the use of these circuits, software, or information.
  2. Renesas Electronics has used reasonable care in preparing the information included in this document, but Renesas Electronics does not warrant that such information is error free. Renesas Electronics assumes no liability whatsoever for any damages incurred by you resulting from errors in or omissions from the information included herein.
  3. Renesas Electronics does not assume any liability for infringement of patents, copyrights, or other intellectual property rights of third parties by or arising from the use of Renesas Electronics products or technical information described in this document. No license, express, implied or otherwise, is granted hereby under any patents, copyrights or other intellectual property rights of Renesas Electronics or others.
  4. You should not alter, modify, copy, or otherwise misappropriate any Renesas Electronics product, whether in whole or in part. Renesas Electronics assumes no responsibility for any losses incurred by you or third parties arising from such alteration, modification, copy or otherwise misappropriation of Renesas Electronics product.
  5. Renesas Electronics products are classified according to the following two quality grades: "Standard" and "High Quality". The recommended applications for each Renesas Electronics product depends on the product's quality grade, as indicated below.  
"Standard": Computers; office equipment; communications equipment; test and measurement equipment; audio and visual equipment; home electronic appliances; machine tools; personal electronic equipment; and industrial robots etc.  
"High Quality": Transportation equipment (automobiles, trains, ships, etc.); traffic control systems; anti-disaster systems; anti-crime systems; and safety equipment etc.  
Renesas Electronics products are neither intended nor authorized for use in products or systems that may pose a direct threat to human life or bodily injury (artificial life support devices or systems, surgical implantations etc.), or may cause serious property damages (nuclear reactor control systems, military equipment etc.). You must check the quality grade of each Renesas Electronics product before using it in a particular application. You may not use any Renesas Electronics product for any application for which it is not intended. Renesas Electronics shall not be in any way liable for any damages or losses incurred by you or third parties arising from the use of any Renesas Electronics product for which the product is not intended by Renesas Electronics.
  6. You should use the Renesas Electronics products described in this document within the range specified by Renesas Electronics, especially with respect to the maximum rating, operating supply voltage range, movement power voltage range, heat radiation characteristics, installation and other product characteristics. Renesas Electronics shall have no liability for malfunctions or damages arising out of the use of Renesas Electronics products beyond such specified ranges.
  7. Although Renesas Electronics endeavors to improve the quality and reliability of its products, semiconductor products have specific characteristics such as the occurrence of failure at a certain rate and malfunctions under certain use conditions. Further, Renesas Electronics products are not subject to radiation resistance design. Please be sure to implement safety measures to guard them against the possibility of physical injury, and injury or damage caused by fire in the event of the failure of a Renesas Electronics product, such as safety design for hardware and software including but not limited to redundancy, fire control and malfunction prevention, appropriate treatment for aging degradation or any other appropriate measures. Because the evaluation of microcomputer software alone is very difficult, please evaluate the safety of the final products or systems manufactured by you.
  8. Please contact a Renesas Electronics sales office for details as to environmental matters such as the environmental compatibility of each Renesas Electronics product. Please use Renesas Electronics products in compliance with all applicable laws and regulations that regulate the inclusion or use of controlled substances, including without limitation, the EU RoHS Directive. Renesas Electronics assumes no liability for damages or losses occurring as a result of your noncompliance with applicable laws and regulations.
  9. Renesas Electronics products and technology may not be used for or incorporated into any products or systems whose manufacture, use, or sale is prohibited under any applicable domestic or foreign laws or regulations. You should not use Renesas Electronics products or technology described in this document for any purpose relating to military applications or use by the military, including but not limited to the development of weapons of mass destruction. When exporting the Renesas Electronics products or technology described in this document, you should comply with the applicable export control laws and regulations and follow the procedures required by such laws and regulations.
  10. It is the responsibility of the buyer or distributor of Renesas Electronics products, who distributes, disposes of, or otherwise places the product with a third party, to notify such third party in advance of the contents and conditions set forth in this document, Renesas Electronics assumes no responsibility for any losses incurred by you or third parties as a result of unauthorized use of Renesas Electronics products.
  11. This document may not be reproduced or duplicated in any form, in whole or in part, without prior written consent of Renesas Electronics.
  12. Please contact a Renesas Electronics sales office if you have any questions regarding the information contained in this document or Renesas Electronics products, or if you have any other inquiries.
- (Note 1) "Renesas Electronics" as used in this document means Renesas Electronics Corporation and also includes its majority-owned subsidiaries.  
(Note 2) "Renesas Electronics product(s)" means any product developed or manufactured by or for Renesas Electronics.



### SALES OFFICES

Renesas Electronics Corporation

<http://www.renesas.com>

Refer to "<http://www.renesas.com/>" for the latest and detailed information.

**Renesas Electronics America Inc.**  
2880 Scott Boulevard Santa Clara, CA 95050-2554, U.S.A.  
Tel: +1-408-588-6000, Fax: +1-408-588-6130

**Renesas Electronics Canada Limited**  
1101 Nicholson Road, Newmarket, Ontario L3Y 9C3, Canada  
Tel: +1-905-898-5441, Fax: +1-905-898-3220

**Renesas Electronics Europe Limited**  
Dukes Meadow, Millboard Road, Bourne End, Buckinghamshire, SL8 5FH, U.K.  
Tel: +44-1628-585-100, Fax: +44-1628-585-900

**Renesas Electronics Europe GmbH**  
Arcadiastrasse 10, 40472 Düsseldorf, Germany  
Tel: +49-211-65030, Fax: +49-211-6503-1327

**Renesas Electronics (China) Co., Ltd.**  
7th Floor, Quantum Plaza, No.27 ZhiChunLu Haidian District, Beijing 100083, P.R.China  
Tel: +86-10-8235-1155, Fax: +86-10-8235-7679

**Renesas Electronics (Shanghai) Co., Ltd.**  
Unit 204, 205, AZIA Center, No.1233 Lujiazui Ring Rd., Pudong District, Shanghai 200120, China  
Tel: +86-21-5877-1818, Fax: +86-21-6887-7858 / -7898

**Renesas Electronics Hong Kong Limited**  
Unit 1601-1613, 16/F., Tower 2, Grand Century Place, 193 Prince Edward Road West, Mongkok, Kowloon, Hong Kong  
Tel: +852-2886-9318, Fax: +852 2886-9022/9044

**Renesas Electronics Taiwan Co., Ltd.**  
13F, No. 363, Fu Shing North Road, Taipei, Taiwan  
Tel: +886-2-8175-9600, Fax: +886 2-8175-9670



**Renesas Electronics Singapore Pte. Ltd.**  
1 HarbourFront Avenue, #06-10, Keppel Bay Tower, Singapore 098632  
Tel: +65-6213-0200, Fax: +65-6278-8001

**Renesas Electronics Malaysia Sdn.Bhd.**  
Unit 906, Block B, Menara Amcorp, Amcorp Trade Centre, No. 18, Jln Persiaran Barat, 46050 Petaling Jaya, Selangor Darul Ehsan, Malaysia  
Tel: +60-3-7955-9390, Fax: +60-3-7955-9510

**Renesas Electronics Korea Co., Ltd.**  
11F., Samik Laved' or Bldg., 720-2 Yeoksam-Dong, Kangnam-Ku, Seoul 135-080, Korea  
Tel: +82-2-558-3737, Fax: +82-2-558-5141

## Looking for pricing, stock, or lifecycle information?

Click below to explore more details on WIN SOURCE:

-  [View RNA51957AFP#H0 on WIN SOURCE](#)
-  [Renesas Electronics America Information](#)

## Optimize Your Supply Chain with WIN SOURCE Solutions

-  Global Sourcing Solution
-  Obsolete Management
-  Cost Control Management
-  Shortage Management
-  Alternative Solution
-  Excess Inventory Management