



**ENGINEERING PRODUCT
SPECIFICATION**

DATE ISSUED: 16/2/2012

CCS-06007

Page 1 of 10

SUBJECT / TITLE :

UNIVERSAL CONTACT SERIES

1 The Products Summary

The Universal Contact series comprises of a metal beam manufactured using a Beryllium Copper alloy or Titanium Copper alloy. The beam is formed up into a protective box provided by the two side wings, which guide the beam within its operating stroke. These side wings are also used to maintain pre-load to the beam in its unmated condition. The contact point of the beam incorporates a 'domed' surface to maintain a high 'hertz stress' contact and good contact resistance.

Height	P/N	Description	Material
1.3mm	120220-0210	Universal Contact 1.3mm	Beryllium Copper alloy
	120220-0303	Universal Contact 1.3mm BF	Titanium Copper alloy
	120220-0302	Universal Contact 1.3mm Smaller	Beryllium Copper alloy
	120220-0309	Universal Contact 1.3mm Smaller BF	Titanium Copper alloy
1.8mm	120220-0202	Universal Contact 1.8mm	Beryllium Copper alloy
	120220-0219	Universal Contact 1.8mm BF	Titanium Copper alloy
	120220-0213	Universal Contact 1.8mm – SPL, RF	Beryllium Copper alloy
2.5mm	120220-0161	Universal Contact 2.5mm	Beryllium Copper alloy
	120220-0301	Universal Contact 2.5mm BF	Titanium Copper alloy
	120220-0307	Universal Contact 2.5mm – SPL, RF	Beryllium Copper alloy
	120220-0215	Universal Contact 2.5mm - Thunder	Beryllium Copper alloy
3.5mm	120220-0204	Universal Contact 3.5mm	Beryllium Copper alloy
	120220-0304	Universal Contact 3.5mm BF	Titanium Copper alloy
	120220-0212	Universal Contact 3.5mm - SPC	Beryllium Copper alloy
	120220-0216	Universal Contact 3.5mm – SPL, RF	Beryllium Copper alloy
4.0mm	120220-0206	Universal Contact 4.0mm	Beryllium Copper alloy
	120220-0308	Universal Contact 4.0mm BF	Titanium Copper alloy
4.6mm	120220-0211	Universal Contact 4.6mm	Beryllium Copper alloy

ECR/ECO NUMBER	R1E-2697	R1E-3153	R1E-3158	R1E-3375	R1E-3385
REVISED BY:	Bills.Liu	Bills.Liu	Bills.Liu	Bills. Liu	Bills. Liu
DATE	2009/05/11	2011/06/13	2011/06/29	2012/02/16	2013/01/07
REVISION	4	5	6	7	8

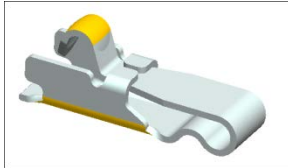
2 The Picture of the products
2.1 UC1.3mm

120220-0210
120220-0303

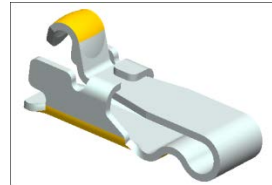

120220-0302
120220-0309

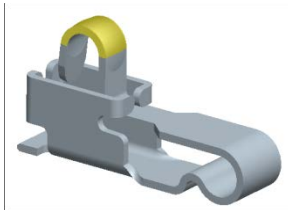
2.2 UC1.8mm

120220-0202
120220-0219

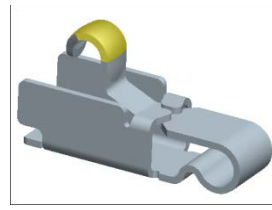

120220-0213

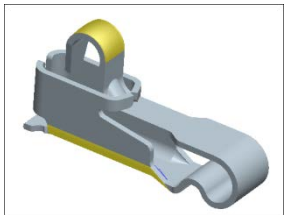
2.3 UC2.5mm

120220-0161
120220-0301

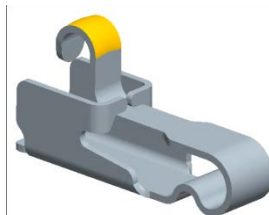

120220-0307

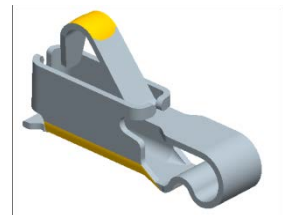

120220-0215

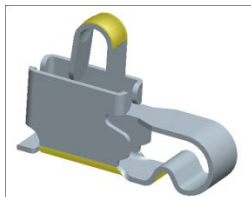
2.4 UC3.5mm

120220-0204
120220-0304
120220-0212

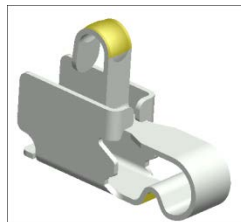

120220-0216

2.5 UC4.0mm

120220-0206
120220-0308

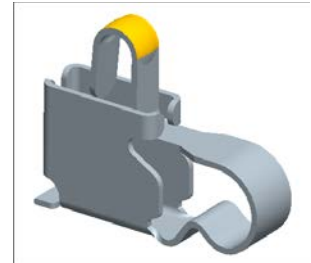
2.6 UC4.6mm

120220-0211

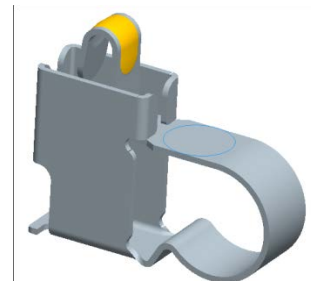

3 Explanation of application

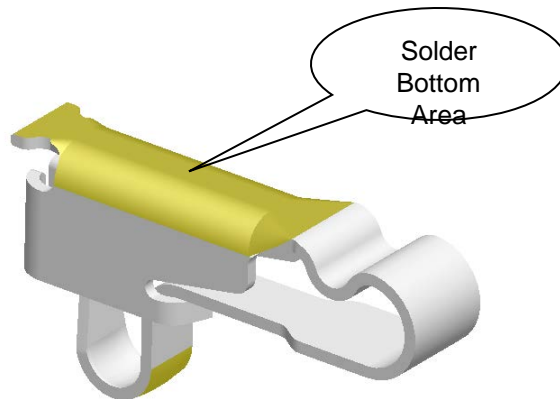
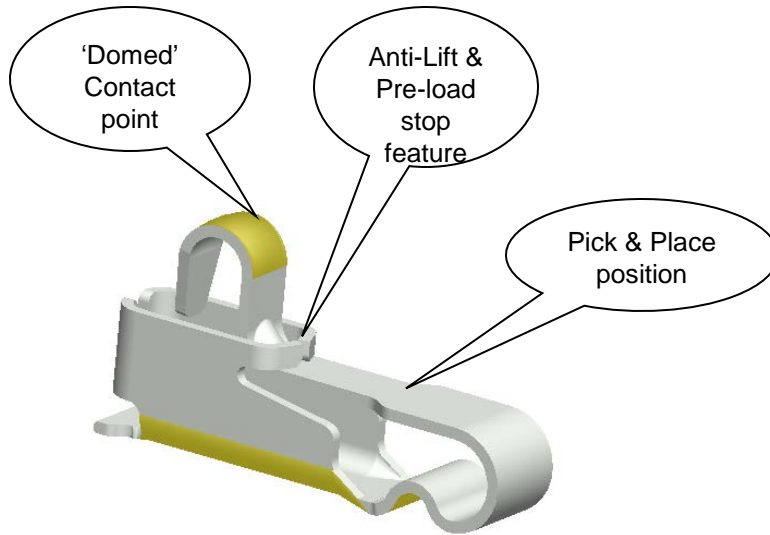



**ENGINEERING PRODUCT
SPECIFICATION**

DATE ISSUED: 16/2/2012

CCS-06007

Page 4 of 10

SUBJECT / TITLE :

UNIVERSAL CONTACT SERIES

4 Dimensions

4.1 dimension Contact

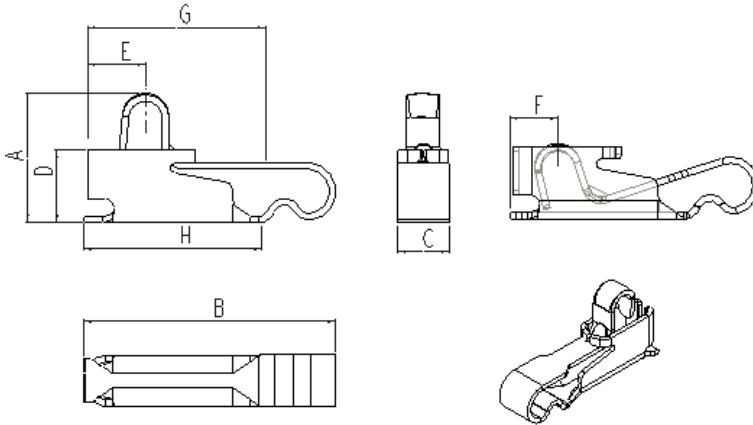

Height	P/N	Dimensions (mm)								Operating Height
		A	B	C	D	E	F	G	H	
1.3mm	120220-0210 / 0303	1.30	3.48	1.10	0.77	0.80	0.30	2.50	2.05	1.30-0.82
	120220-0302 / 0309	1.30	3.08	1.10	0.77	0.40	0.28	2.30	2.05	
1.8mm	120220-0202 / 0219	1.80	3.40	0.90	1.00	0.84	0.47	2.40	2.35	1.70-1.00
	120220-0213	1.80	3.40	1.19	1.00	0.84	0.47	2.40	2.35	
2.5mm	120220-0161 / 0301	2.50	4.87	0.98	1.40	1.19	0.74	2.80	3.38	2.40-1.40
	120220-0307	2.50	4.87	1.45	1.40	1.19	0.74	2.90	3.38	
	120220-0215	2.50	4.87	0.98	1.40	N.D	N.D	2.90	3.38	
3.5mm	120220-0204 / 0304 / 0212	3.50	5.00	1.08	2.00	1.65	0.50	3.40	3.25	3.40-2.00
	120220-0216	3.50	5.00	1.40	2.00	1.65	0.50	3.40	3.25	
4.0mm	120220-0206 / 0308	4.00	5.00	1.10	2.50	1.58	0.45	3.40	3.00	3.90-2.50
4.6mm	120220-0211	4.60	5.40	1.40	3.50	1.30	0.68	3.35	2.68	4.50-3.50

4.2 Recommended PCB layout

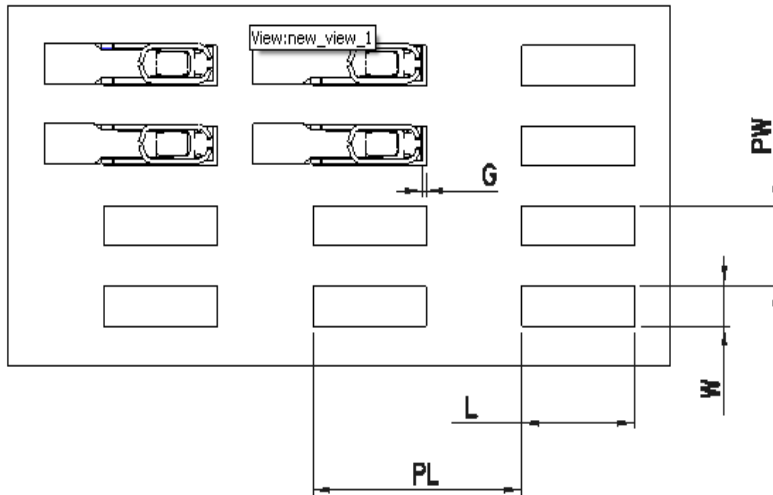

Height	P/N	Dimensions (mm)				
		L	W	PL	PW	G
1.3mm	120220-0210 / 0303	2.45	1.10	4.00	1.45	0.10
	120220-0302 / 0309	2.45	1.10	3.60	1.45	0.10
1.8mm	120220-0202 / 0219	2.75	0.90	3.90	1.25	0.10
	120220-0213	2.75	0.90	3.90	1.54	0.10
2.5mm	120220-0161 / 0301	3.76	1.00	5.50	1.35	0.10
	120220-0307	3.76	1.00	5.50	1.75	0.10
	120220-0215	3.76	1.00	5.50	1.35	0.10
3.5mm	120220-0204 / 0304 / 0212	3.65	1.10	5.50	1.45	0.10
	120220-0216	3.65	1.10	5.50	1.80	0.10
4.0mm	120220-0206 / 0308	3.36	1.10	5.50	1.75	0.10
4.6mm	120220-0211	2.80	1.40	5.90	1.75	0.10

4.3 Recommended soldering pad thickness : 0.1 mm



**ENGINEERING PRODUCT
SPECIFICATION**

DATE ISSUED: 16/2/2012

CCS-06007

Page 6 of 10

SUBJECT / TITLE :

UNIVERSAL CONTACT SERIES

5 Finishes

Note : Sealing post-treatment after plating process is applied.

Height	P/N	Plating on contact position	Plating on soldering position	
1.3mm	120220-0210 / 0303	1.0 um Au over 1.0/3.0 um Ni.	0.05/0.15 um Au over 1.0/3.0 um Ni	
	120220-0302 / 0309			
1.8mm	120220-0202 / 0219			
	120220-0213			
2.5mm	120220-0161 / 0301			
	120220-0307			
	120220-0215			
3.5mm	120220-0204 / 0304			
	120220- 0212			0.3 um Au over 1.0/3.0 um Ni.
	120220-0216			1.0 um Au over 1.0/3.0 um Ni.
4.0mm	120220-0206 / 0308			
4.6mm	120220-0211			



ENGINEERING PRODUCT SPECIFICATION

DATE ISSUED: 16/2/2012

CCS-06007

Page 7 of 10

SUBJECT / TITLE :

UNIVERSAL CONTACT SERIES

6 Mechanical

6.1 Mechanical Performance--Force/Deflection

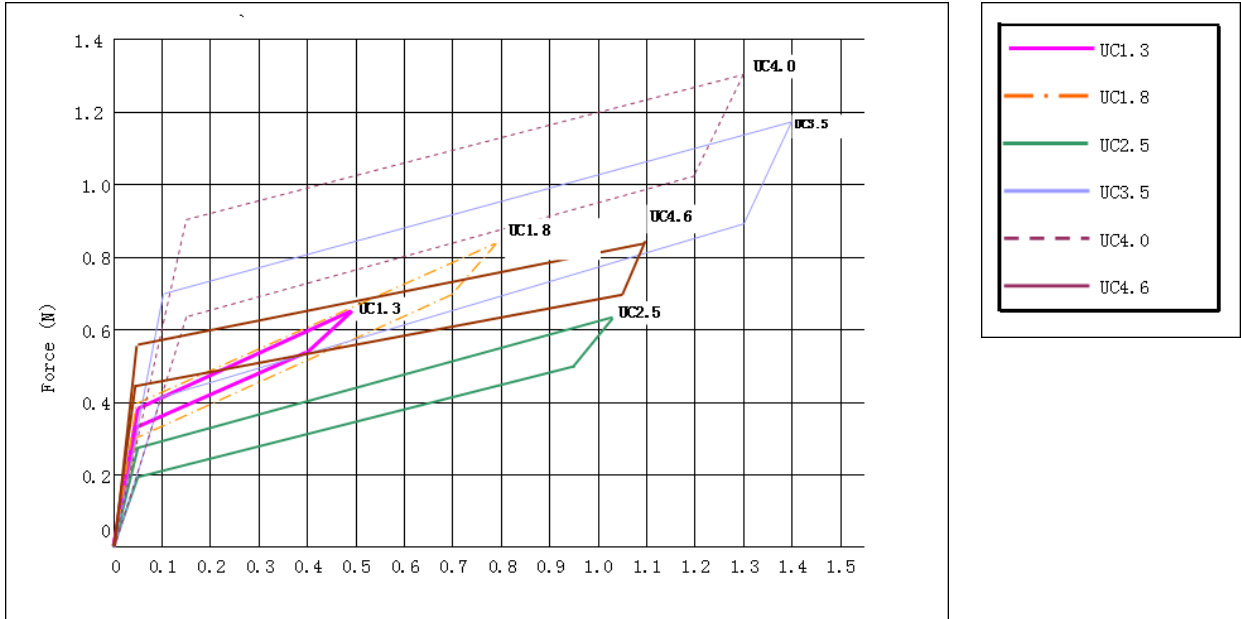

Mechanical Performance (All force data after 3x Reflow at 260° C)

Height	P/N	Pre-Load Applying Load (N)	Pre-Load Un-Applying Load (N)	Max Deflection(mm) --Min tolerance conditions	Mating Force @ Max Deflection (N)	Spring Rate (N/mm)
1.3mm	120220-0210 120220-0303 120220-0302 120220-0309	0.39	0.34	0.50	0.68	0.68
1.8mm	120220-0202 / 0219 / 0213	0.40	0.30	0.80	0.87	0.63
2.5mm	120220-0161 120220-0301 120220-0307 120220-0215	0.45	0.35	1.05	0.90	0.86
3.5mm	120220-0204 120220-0304 120220-0212 120220-0216	0.69	0.44	1.30	1.16	0.36
4.0mm	120220-0206 / 0308	0.90	0.65	1.30	1.30	0.35
4.6mm	120220-0211	0.56	0.38	1.10	0.81	0.34



**ENGINEERING PRODUCT
SPECIFICATION**

DATE ISSUED: 16/2/2012

CCS-06007

Page 8 of 10

SUBJECT / TITLE :

UNIVERSAL CONTACT SERIES

6.2 Durability---Mating Cycles: 100 min. Up to and over 3000 cycles may be achieved depending on mating surface. Maximum mating cycle based on mating PCB plated with 0.05 μ Au over 2.0 μ Ni = 3000 cycles.
(Wear resistance is subject to mating component surface finish and plating type, increased mating component plating spec = increased mating cycles.)

6.3 Vibration---The test samples were subjected to the following vibration profile:

5Hz to 9Hz @ 1.5mm pk Displacement
9Hz to 200Hz @ 0.5g pk Acceleration
1 Oct per minute; 1 Hour per axis. 3 Axis total.

6.4 Shock ---The test samples were subjected to the following shock:

100g pk Acceleration
11ms duration
3 shocks in each axis
6 directions

7 Electrical

Contact Resistance: Max 20 m Ω

8 Environmental

8.1 Operating Temperature: Usable in temperatures between -40 and +85° C.

8.2 Humidity: Operable in 90% Relative Humidity (Temperature <40° C).

8.3 Lower Temperature : -57° C(24hours) followed by -51° C(48hours)

8.4 High temperature: +85° C(24hours) followed by 71° C(144hours)

8.3 Solder Systems: Suitable for lead free reflow soldering at 260° C. Max. 3 x reflow cycles recommended. According to JEDEC Standard J-STD-020C

Hand Soldering
Wave line Soldering
Infrared Reflow Soldering

Table 5-2 Classification Reflow Profiles

Profile Feature	Sn-Pb Eutectic Assembly	Pb-Free Assembly
Average Ramp-Up Rate (Ts _{max} to Tp)	3 °C/second max.	3° C/second max.
Preheat – Temperature Min (Ts _{min}) – Temperature Max (Ts _{max}) – Time (ts _{min} to ts _{max})	100 °C 150 °C 60-120 seconds	150 °C 200 °C 60-180 seconds
Time maintained above: – Temperature (T _L) – Time (t _L)	183 °C 60-150 seconds	217 °C 60-150 seconds
Peak/Classification Temperature (Tp)	See Table 4.1	See Table 4.2
Time within 5 °C of actual Peak Temperature (tp)	10-30 seconds	20-40 seconds
Ramp-Down Rate	6 °C/second max.	6 °C/second max.
Time 25 °C to Peak Temperature	6 minutes max.	8 minutes max.

Note 1: All temperatures refer to topside of the package, measured on the package body surface.

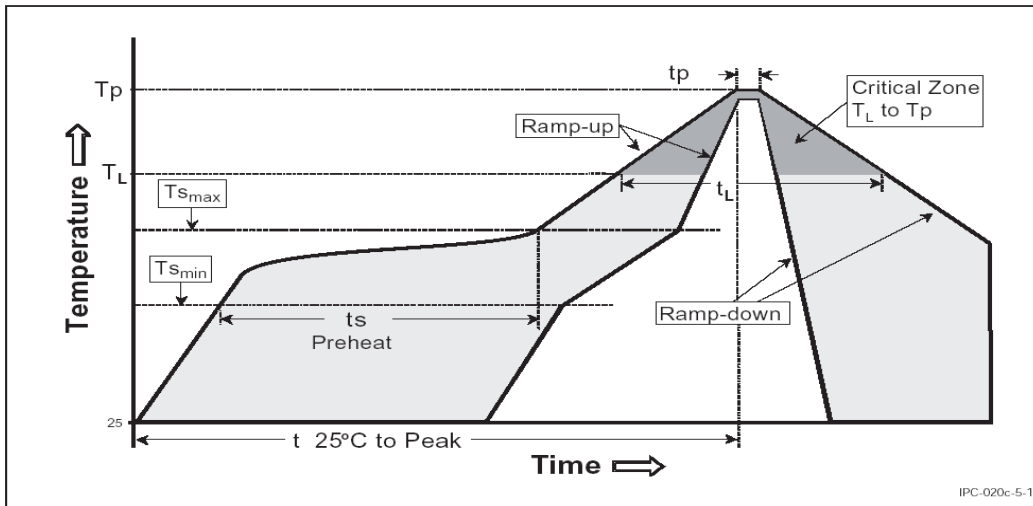

Figure 5-1 Classification Reflow Profile

Table 4-1 SnPb Eutectic Process – Package Peak Reflow Temperatures

Package Thickness	Volume mm ³ <350	Volume mm ³ ≥ 350
<2.5 mm	240 +0/-5 °C	225 +0/-5°C
≥ 2.5 mm	225 +0/-5°C	225 +0/-5°C

Table 4-2 Pb-free Process – Package Classification Reflow Temperatures

Package Thickness	Volume mm ³ <350	Volume mm ³ 350 - 2000	Volume mm ³ >2000
<1.6 mm	260 +0 °C *	260 +0 °C *	260 +0 °C *
1.6 mm - 2.5 mm	260 +0 °C *	250 +0 °C *	245 +0 °C *
≥2.5 mm	250 +0 °C *	245 +0 °C *	245 +0 °C *

* Tolerance: The device manufacturer/supplier shall assure process compatibility up to and including the stated classification temperature (this means Peak reflow temperature +0 °C. For example 260 °C+0°C) at the rated MSL level.

Note 1: The profiling tolerance is + 0 °C, -X °C (based on machine variation capability) whatever is required to control the profile process but at no time will it exceed - 5 °C. The producer assures process compatibility at the peak reflow profile temperatures defined in Table 4.2.

Note 2: Package volume excludes external terminals (balls, bumps, lands, leads) and/or nonintegral heat sinks.

Note 3: The maximum component temperature reached during reflow depends on package thickness and volume. The use of convection reflow processes reduces the thermal gradients between packages. However, thermal gradients due to differences in thermal mass of SMD packages may still exist.

Note 4: Components intended for use in a "lead-free" assembly process shall be evaluated using the "lead free" classification temperatures and profiles defined in Tables 4-1, 4.2 and 5-2 whether or not lead free.



ENGINEERING PRODUCT SPECIFICATION

DATE ISSUED: 16/2/2012

CCS-06007

Page 10 of 10

SUBJECT / TITLE :

UNIVERSAL CONTACT SERIES

9 Packing & SMT

Packing: Parts are packed in carrier and reel. The width of carrier tape is 12mm and the diameter of reel is 300mm which are according to the standard EIA-481. For packing quantity see table below.

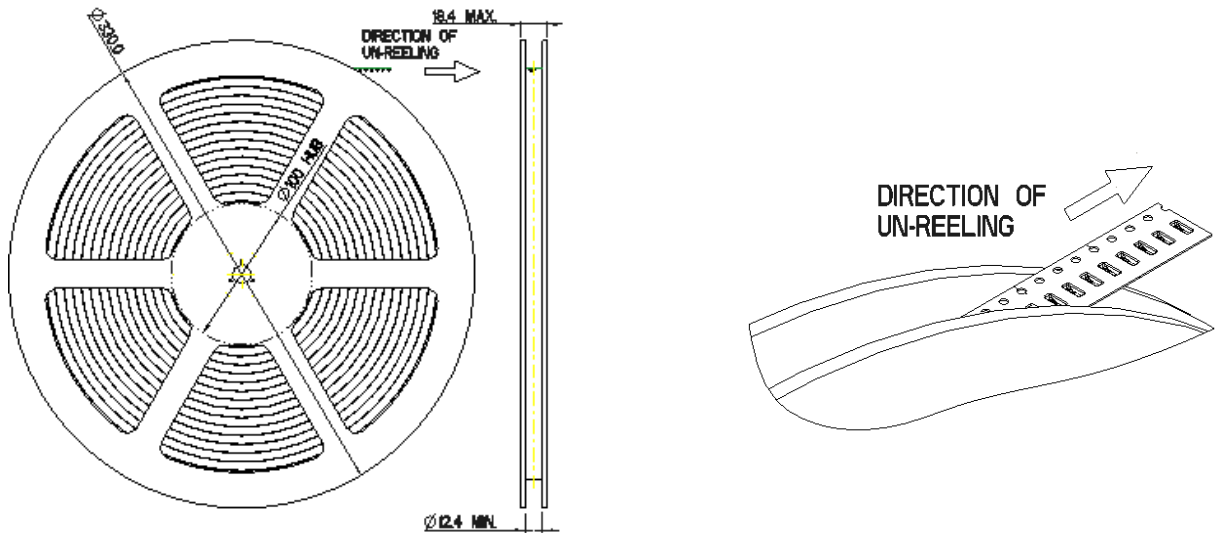

Height	P/N	MPQ (pcs)-Per reel	MOQ (pcs)-Per carton
1.3mm	120220-0210 120220-0303 120220-0302 120220-0309	9500	114000
1.8mm	120220-0202 / 0219 / 0213	6800	81600
2.5mm	120220-0161 120220-0301 120220-0307 120220-0215	6000	72000
3.5mm	120220-0204 120220-0304 120220-0212 120220-0216	3600	43200
4.0mm	120220-0206 / 0308	3200	38400
4.6mm	120220-0211	3500	42000

For further information on pick and place methods and advice when using Universal Contact please refer to ITT Application note APN-06001.







Looking for pricing, stock, or lifecycle information?

Click below to explore more details on WIN SOURCE:

 [View 120220-0161](#) on WIN SOURCE

 [ITT Cannon, LLC](#) Information

Optimize Your Supply Chain with WIN SOURCE Solutions

-  Global Sourcing Solution
-  Obsolete Management
-  Cost Control Management
-  Shortage Management
-  Alternative Solution
-  Excess Inventory Management