



Is Now Part of



ON Semiconductor®

To learn more about ON Semiconductor, please visit our website at
www.onsemi.com

Please note: As part of the Fairchild Semiconductor integration, some of the Fairchild orderable part numbers will need to change in order to meet ON Semiconductor's system requirements. Since the ON Semiconductor product management systems do not have the ability to manage part nomenclature that utilizes an underscore (_), the underscore (_) in the Fairchild part numbers will be changed to a dash (-). This document may contain device numbers with an underscore (_). Please check the ON Semiconductor website to verify the updated device numbers. The most current and up-to-date ordering information can be found at www.onsemi.com. Please email any questions regarding the system integration to Fairchild_questions@onsemi.com.

ON Semiconductor and the ON Semiconductor logo are trademarks of Semiconductor Components Industries, LLC dba ON Semiconductor or its subsidiaries in the United States and/or other countries. ON Semiconductor owns the rights to a number of patents, trademarks, copyrights, trade secrets, and other intellectual property. A listing of ON Semiconductor's product/patent coverage may be accessed at www.onsemi.com/site/pdf/Patent-Marking.pdf. ON Semiconductor reserves the right to make changes without further notice to any products herein. ON Semiconductor makes no warranty, representation or guarantee regarding the suitability of its products for any particular purpose, nor does ON Semiconductor assume any liability arising out of the application or use of any product or circuit, and specifically disclaims any and all liability, including without limitation special, consequential or incidental damages. Buyer is responsible for its products and applications using ON Semiconductor products, including compliance with all laws, regulations and safety requirements or standards, regardless of any support or applications information provided by ON Semiconductor. "Typical" parameters which may be provided in ON Semiconductor data sheets and/or specifications can and do vary in different applications and actual performance may vary over time. All operating parameters, including "Typicals" must be validated for each customer application by customer's technical experts. ON Semiconductor does not convey any license under its patent rights nor the rights of others. ON Semiconductor products are not designed, intended, or authorized for use as a critical component in life support systems or any FDA Class 3 medical devices or medical devices with a same or similar classification in a foreign jurisdiction or any devices intended for implantation in the human body. Should Buyer purchase or use ON Semiconductor products for any such unintended or unauthorized application, Buyer shall indemnify and hold ON Semiconductor and its officers, employees, subsidiaries, affiliates, and distributors harmless against all claims, costs, damages, and expenses, and reasonable attorney fees arising out of, directly or indirectly, any claim of personal injury or death associated with such unintended or unauthorized use, even if such claim alleges that ON Semiconductor was negligent regarding the design or manufacture of the part. ON Semiconductor is an Equal Opportunity/Affirmative Action Employer. This literature is subject to all applicable copyright laws and is not for resale in any manner.

FOD3180

2A Output Current, High Speed MOSFET Gate Driver Optocoupler

Features

- Guaranteed operating temperature range of -40°C to +100°C
- 2A minimum peak output current
- High speed response: 200ns max propagation delay over temperature range
- 250kHz maximum switching speed
- 30ns typ pulse width distortion
- Wide V_{CC} operating range: 10V to 20V
- 5000Vrms, 1 minute isolation
- Under voltage lockout protection (UVLO) with hysteresis
- Minimum creepage distance of 7.0mm
- Minimum clearance distance of 7.0mm
- C-UL, UL and VDE* approved
- $R_{DS(ON)}$ of 1.5Ω (typ.) offers lower power dissipation
- 15kV/μs minimum common mode rejection

Applications

- Plasma Display Panel
- High performance DC/DC convertor
- High performance switch mode power supply
- High performance uninterruptible power supply
- Isolated Power MOSFET gate drive

*Requires 'V' ordering option

Description

The FOD3180 is a 2A Output Current, High Speed MOSFET Gate Drive Optocoupler. It consists of an aluminium gallium arsenide (AlGaAs) light emitting diode optically coupled to a CMOS detector with PMOS and NMOS output power transistors integrated circuit power stage. It is ideally suited for high frequency driving of power MOSFETs used in Plasma Display Panels (PDPs), motor control inverter applications and high performance DC/DC converters.

The device is packaged in an 8-pin dual in-line housing compatible with 260°C reflow processes for lead free solder compliance.

Functional Block Diagram

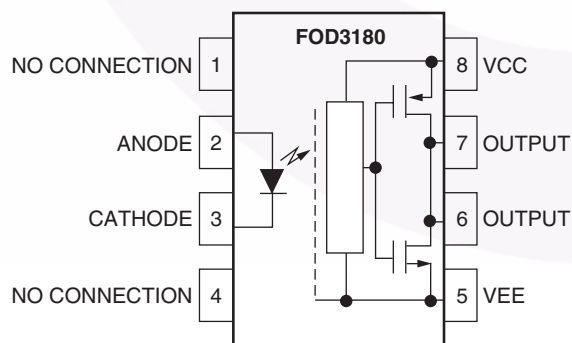

Note:

A 0.1μF bypass capacitor must be connected between pins 5 and 8.

Package Outlines

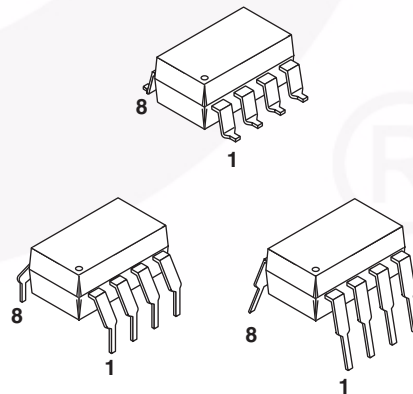

Absolute Maximum Ratings ($T_A = 25^\circ\text{C}$ unless otherwise specified)

Stresses exceeding the absolute maximum ratings may damage the device. The device may not function or be operable above the recommended operating conditions and stressing the parts to these levels is not recommended. In addition, extended exposure to stresses above the recommended operating conditions may affect device reliability. The absolute maximum ratings are stress ratings only.

| Symbol | Parameter | Value | Units |
|-------------------|---|-----------------|------------------|
| T_{STG} | Storage Temperature | -40 to +125 | $^\circ\text{C}$ |
| T_{OPR} | Operating Temperature | -40 to +100 | $^\circ\text{C}$ |
| T_J | Junction Temperature | -40 to +125 | $^\circ\text{C}$ |
| T_{SOL} | Lead Solder Temperature | 260 for 10 sec. | $^\circ\text{C}$ |
| $I_{F(AVG)}$ | Average Input Current ⁽¹⁾ | 25 | mA |
| $I_{F(tr, tf)}$ | LED Current Minimum Rate of Rise/Fall | 250 | ns |
| $I_{F(TRAN)}$ | Peak Transient Input Current (<1 μs pulse width, 300pps) | 1.0 | A |
| V_R | Reverse Input Voltage | 5 | V |
| $I_{OH(PEAK)}$ | “High” Peak Output Current ⁽²⁾ | 2.5 | A |
| $I_{OL(PEAK)}$ | “Low” Peak Output Current ⁽²⁾ | 2.5 | A |
| $V_{CC} - V_{EE}$ | Supply Voltage | -0.5 to 25 | V |
| $V_{O(PEAK)}$ | Output Voltage | 0 to V_{CC} | V |
| P_O | Output Power Dissipation ⁽⁴⁾ | 250 | mW |
| P_D | Total Power Dissipation ⁽⁵⁾ | 295 | mW |

Recommended Operating Conditions

The Recommended Operating Conditions table defines the conditions for actual device operation. Recommended operating conditions are specified to ensure optimal performance to the datasheet specifications. Fairchild does not recommend exceeding them or designing to absolute maximum ratings.

| Symbol | Parameter | Value | Units |
|-------------------|---------------------|-------------|-------|
| $V_{CC} - V_{EE}$ | Power Supply | 10 to 20 | V |
| $I_{F(ON)}$ | Input Current (ON) | 10 to 16 | mA |
| $V_{F(OFF)}$ | Input Voltage (OFF) | -3.0 to 0.8 | V |

Electrical-Optical Characteristics (DC)

Over recommended operating conditions unless otherwise specified.

| Symbol | Parameter | Test Conditions | Min. | Typ.* | Max. | Unit |
|---------------------------------|---|--|-----------------------|-------|-----------------------|-------|
| I _{OH} | High Level Output Current ⁽²⁾⁽³⁾ | V _{OH} = (V _{CC} - V _{EE} - 1V) | 0.5 | | | A |
| | | V _{OH} = (V _{CC} - V _{EE} - 3V) | 2.0 | | | |
| I _{OL} | Low Level Output Current ⁽²⁾⁽³⁾ | V _{OL} = (V _{CC} - V _{EE} - 1V) | 0.5 | | | A |
| | | V _{OL} = (V _{CC} - V _{EE} - 3V) | 2.0 | | | |
| V _{OH} | High Level Output Voltage ⁽⁶⁾⁽⁷⁾ | I _O = -100mA | V _{CC} - 0.5 | | | V |
| V _{OL} | Low Level Output Voltage ⁽⁶⁾⁽⁷⁾ | I _O = 100mA | | | V _{EE} + 0.5 | V |
| I _{CCH} | High Level Supply Current | Output Open, I _F = 10 to 16mA | | 4.8 | 6.0 | mA |
| I _{CCL} | Low Level Supply Current | Output Open, V _F = -3.0 to 0.8V | | 5.0 | 6.0 | mA |
| I _{FLH} | Threshold Input Current Low to High | I _O = 0mA, V _O > 5V | | | 8.0 | mA |
| V _{FHL} | Threshold Input Voltage High to Low | I _O = 0mA, V _O < 5V | 0.8 | | | V |
| V _F | Input Forward Voltage | I _F = 10mA | 1.2 | 1.43 | 1.8 | V |
| ΔV _F /T _A | Temperature Coefficient of Forward Voltage | I _F = 10mA | | -1.5 | | mV/°C |
| V _{UVLO+} | UVLO Threshold | V _O > 5V, I _F = 10mA | | 8.3 | | V |
| V _{UVLO-} | | V _O < 5V, I _F = 10mA | | 7.7 | | V |
| UVLO _{HYST} | UVLO Hysteresis | | | 0.6 | | V |
| BV _R | Input Reverse Breakdown Voltage | I _R = 10μA | 5 | | | V |
| C _{IN} | Input Capacitance | f = 1MHz, V _F = 0V | | 60 | | pF |

*Typical values at T_A = 25°C

Switching Characteristics

Over recommended operating conditions unless otherwise specified.

| Symbol | Parameter | Test Conditions | Min. | Typ.* | Max. | Unit |
|-------------------------------------|---|--|------|-------|------|-------------------------|
| t_{PLH} | Propagation Delay Time to High Output Level ⁽⁸⁾ | $I_F = 10\text{mA}$, $R_g = 10\Omega$, $f = 250\text{kHz}$, Duty Cycle = 50%, $C_g = 10\text{nF}$ | 50 | 135 | 200 | ns |
| t_{PHL} | Propagation Delay Time to Low Output Level ⁽⁸⁾ | | 50 | 105 | 200 | ns |
| P_{WD} | Pulse Width Distortion ⁽⁹⁾ | | | | 65 | ns |
| P_{DD} ($t_{PHL} - t_{PLH}$) | Propagation Delay Difference Between Any Two Parts ⁽¹⁰⁾ | | -90 | | 90 | ns |
| t_r | Rise Time | $C_L = 10\text{nF}$, | | 75 | | ns |
| t_f | Fall Time | $R_g = 10\Omega$ | | 55 | | ns |
| $t_{UVLO\ ON}$ | UVLO Turn On Delay | | | 2.0 | | μs |
| $t_{UVLO\ OFF}$ | UVLO Turn Off Delay | | | 0.3 | | μs |
| $ CM_H $ | Output High Level Common Mode Transient Immunity ^{(11) (12)} | $T_A = +25^\circ\text{C}$, $I_f = 10$ to 16mA , $V_{CM} = 1.5\text{kV}$, $V_{CC} = 20\text{V}$ | 15 | | | $\text{kV}/\mu\text{s}$ |
| $ CM_L $ | Output Low Level Common Mode Transient Immunity ^{(11) (13)} | $T_A = +25^\circ\text{C}$, $V_f = 0\text{V}$, $V_{CM} = 1.5\text{kV}$, $V_{CC} = 20\text{V}$ | 15 | | | $\text{kV}/\mu\text{s}$ |

*Typical values at $T_A = 25^\circ\text{C}$

Isolation Characteristics

| Symbol | Parameter | Test Conditions | Min. | Typ.* | Max. | Unit |
|-----------|--|--|------|-----------|------|------------------|
| V_{ISO} | Withstand Isolation Voltage ^{(14) (15)} | $T_A = 25^\circ\text{C}$, R.H. < 50%, $t = 1\text{min.}$, $I_{I-O} \leq 20\mu\text{A}$ | 5000 | | | V_{rms} |
| R_{I-O} | Resistance (input to output) ⁽¹⁵⁾ | $V_{I-O} = 500\text{V}$ | | 10^{11} | | Ω |
| C_{I-O} | Capacitance (input to output) | Freq. = 1MHz | | 1 | | pF |

*Typical values at $T_A = 25^\circ\text{C}$

Notes:

1. Derate linearly above +70°C free air temperature at a rate of 0.3mA/°C.
2. The output currents I_{OH} and I_{OL} are specified with a capacitive current limited load = $(3 \times 0.01\mu\text{F}) + 0.5\Omega$, frequency = 8kHz, 50% DF.
3. The output currents I_{OH} and I_{OL} are specified with a capacitive current limited load = $(3 \times 0.01\mu\text{F}) + 8.5\Omega$, frequency = 8kHz, 50% DF.
4. Derate linearly above +87°C, free air temperature at the rate of 0.77mW/°C. Refer to Figure 12.
5. No derating required across operating temperature range.
6. In this test, V_{OH} is measured with a dc load current of 100mA. When driving capacitive load V_{OH} will approach V_{CC} as I_{OH} approaches zero amps.
7. Maximum pulse width = 1ms, maximum duty cycle = 20%.
8. t_{PHL} propagation delay is measured from the 50% level on the falling edge of the input pulse to the 50% level of the falling edge of the V_O signal. t_{PLH} propagation delay is measured from the 50% level on the rising edge of the input pulse to the 50% level of the rising edge of the V_O signal.
9. PWD is defined as $|t_{PHL} - t_{PLH}|$ for any given device.
10. The difference between t_{PHL} and t_{PLH} between any two FOD3180 parts under same test conditions.
11. Pin 1 and 4 need to be connected to LED common.
12. Common mode transient immunity in the high state is the maximum tolerable dV_{CM}/dt of the common mode pulse V_{CM} to assure that the output will remain in the high state (i.e. $V_O > 10.0V$).
13. Common mode transient immunity in a low state is the maximum tolerable dV_{CM}/dt of the common mode pulse, V_{CM} , to assure that the output will remain in a low state (i.e. $V_O < 1.0V$).
14. In accordance with UL 1577, each optocoupler is proof tested by applying an insulation test voltage > 6000Vrms, 60Hz for 1 second (leakage detection current limit $I_{I-O} < 5\mu\text{A}$).
15. Device considered a two-terminal device: pins on input side shorted together and pins on output side shorted together.

Typical Performance Curves

Fig. 1 Input Forward Current vs. Forward Voltage

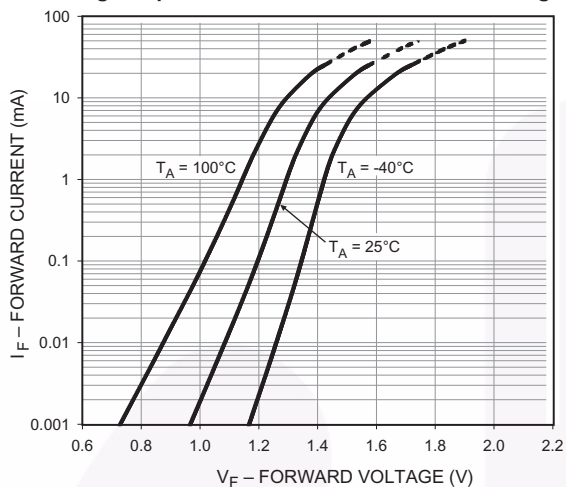

Fig. 2 Low To High Input Current Threshold vs. Ambient Temperature

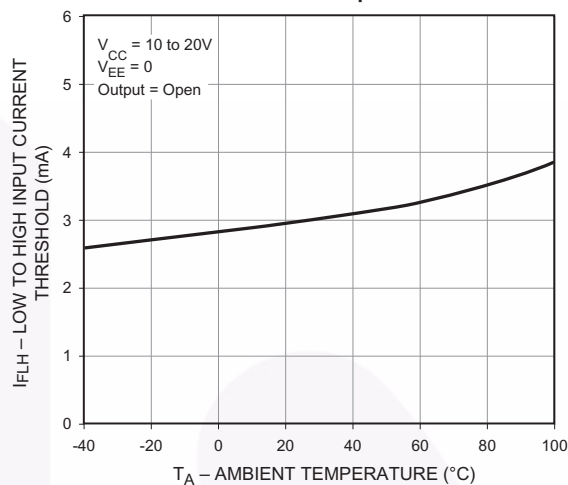

Fig. 3 Output Low Voltage vs. Ambient Temperature

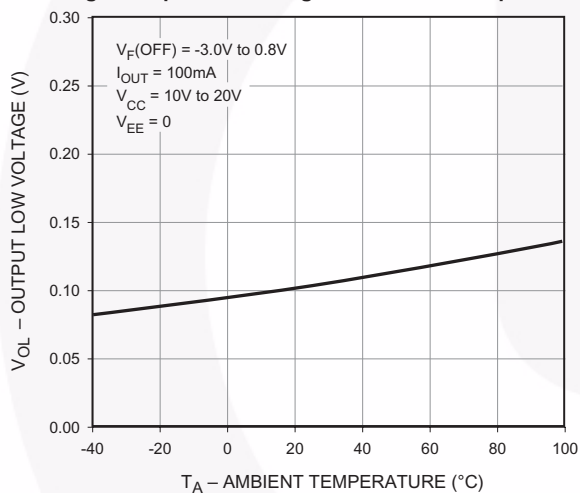

Fig. 4 High Output Voltage Drop vs. Ambient Temperature

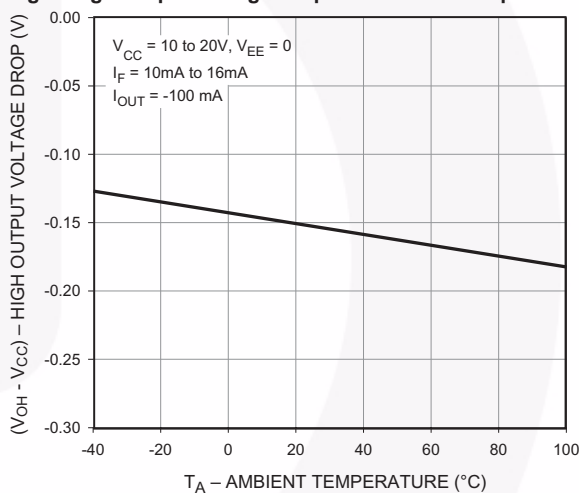

Fig. 5 Supply Current vs. Ambient Temperature

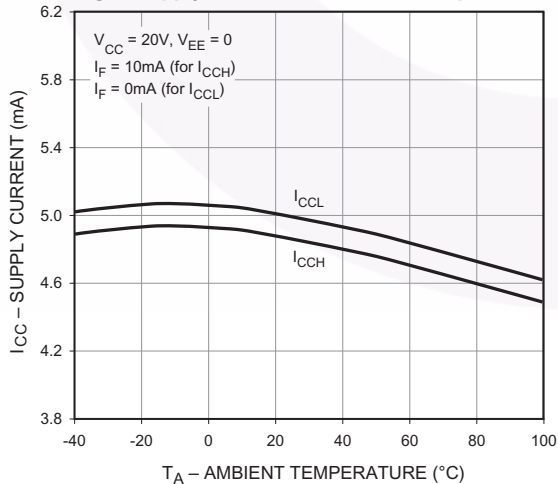
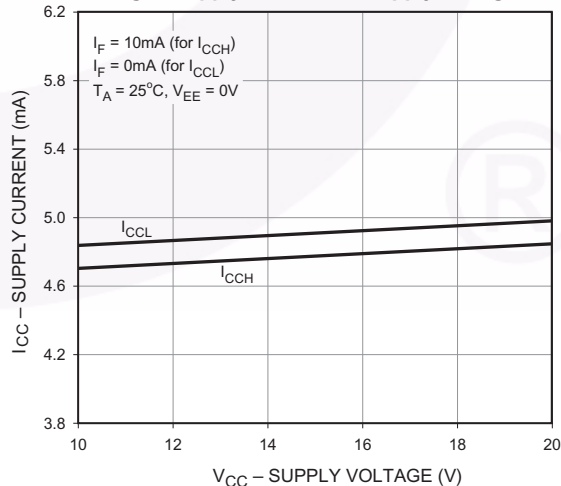

Fig. 6 Supply Current vs. Supply Voltage



Typical Performance Curves (Continued)

Fig. 7 Propagation Delay vs. Load Capacitance

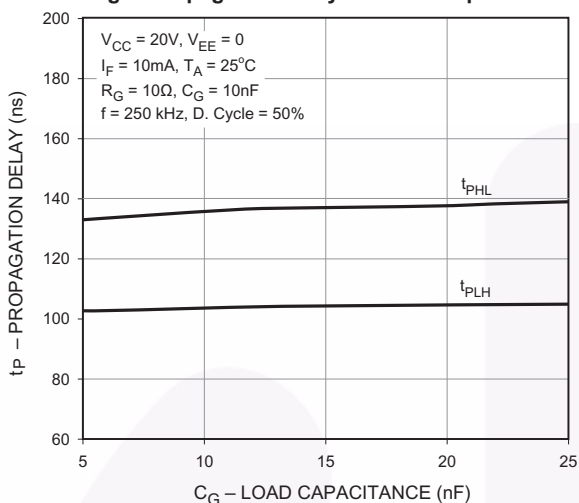

Fig. 8 Propagation Delay vs. Forward LED Current

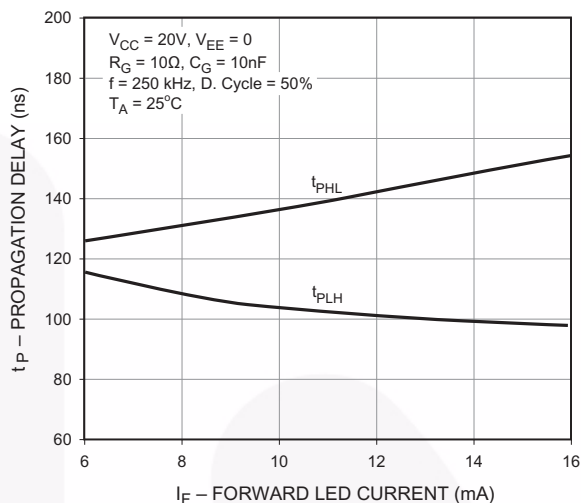

Fig. 9 Propagation Delay vs. Series Load Resistance

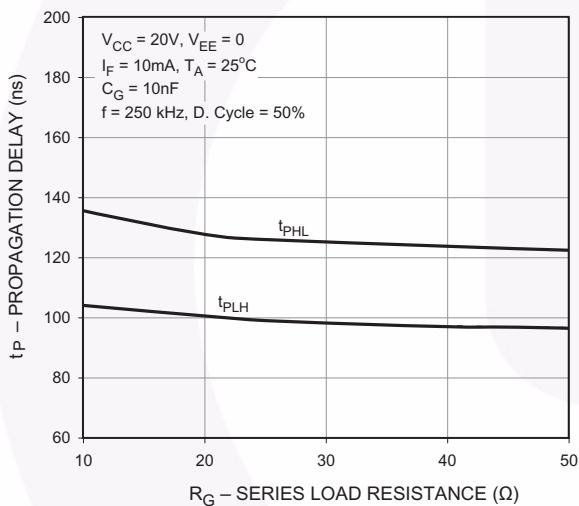

Fig. 10 Propagation Delay vs. Ambient Temperature

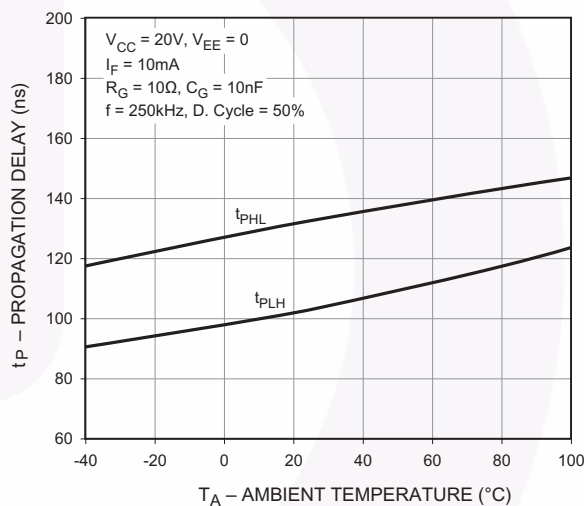
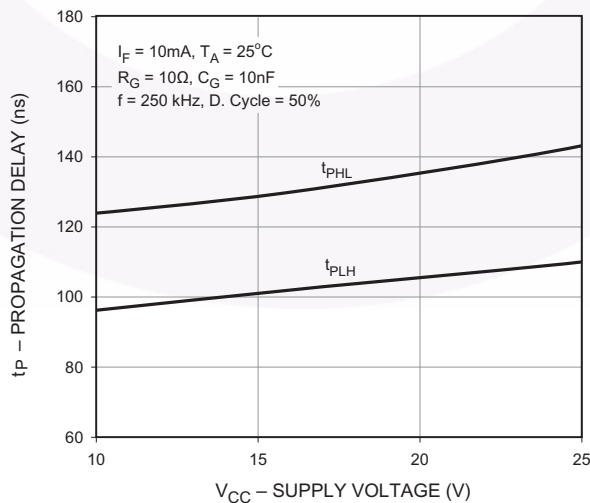

Fig. 11 Propagation Delay vs. Supply Voltage



Ordering Information

| Option | Order Entry Identifier (Example) | Description |
|-----------|----------------------------------|--|
| No option | FOD3180 | Standard Through Hole Device |
| S | FOD3180S | Surface Mount, Lead Bend |
| SD | FOD3180SD | Surface Mount, Tape and Reel |
| T | FOD3180T | 0.4" Lead Spacing |
| V | FOD3180V | VDE 0884 |
| TV | FOD3180TV | VDE 0884, 0.4" Lead Spacing |
| SV | FOD3180SV | VDE 0884, Surface Mount |
| SDV | FOD3180SDV | VDE 0884, Surface Mount, Tape and Reel |

Marking Information

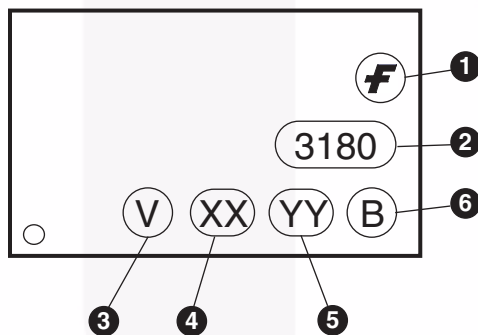

Definitions

| | |
|---|--|
| 1 | Fairchild logo |
| 2 | Device number |
| 3 | VDE mark (Note: Only appears on parts ordered with VDE option – See order entry table) |
| 4 | Two digit year code, e.g., '03' |
| 5 | Two digit work week ranging from '01' to '53' |
| 6 | Assembly package code |

Carrier Tape Specifications

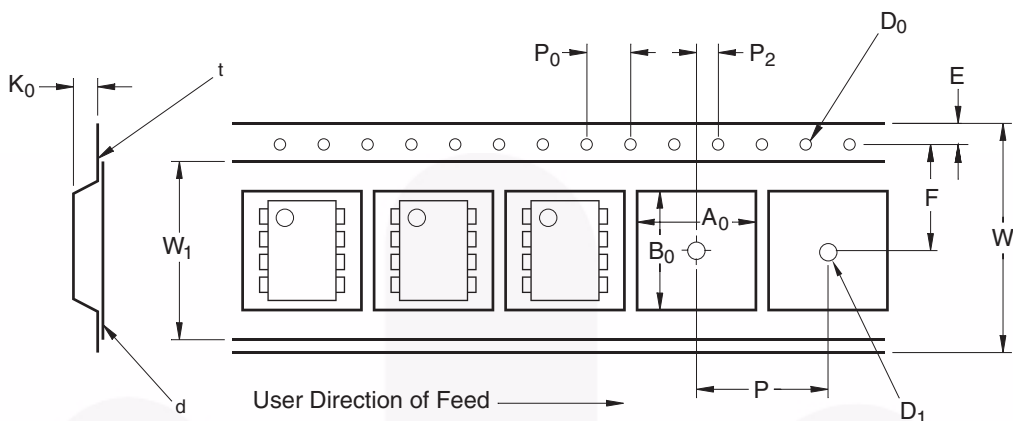

| Symbol | Description | Dimension in mm |
|----------------|---------------------------------|-----------------|
| W | Tape Width | 16.0 ± 0.3 |
| t | Tape Thickness | 0.30 ± 0.05 |
| P ₀ | Sprocket Hole Pitch | 4.0 ± 0.1 |
| D ₀ | Sprocket Hole Diameter | 1.55 ± 0.05 |
| E | Sprocket Hole Location | 1.75 ± 0.10 |
| F | Pocket Location | 7.5 ± 0.1 |
| P ₂ | | 4.0 ± 0.1 |
| P | Pocket Pitch | 12.0 ± 0.1 |
| A ₀ | Pocket Dimensions | 10.30 ± 0.20 |
| B ₀ | | 10.30 ± 0.20 |
| K ₀ | | 4.90 ± 0.20 |
| W ₁ | Cover Tape Width | 1.6 ± 0.1 |
| d | Cover Tape Thickness | 0.1 max |
| | Max. Component Rotation or Tilt | 10° |
| R | Min. Bending Radius | 30 |

Reflow Profile

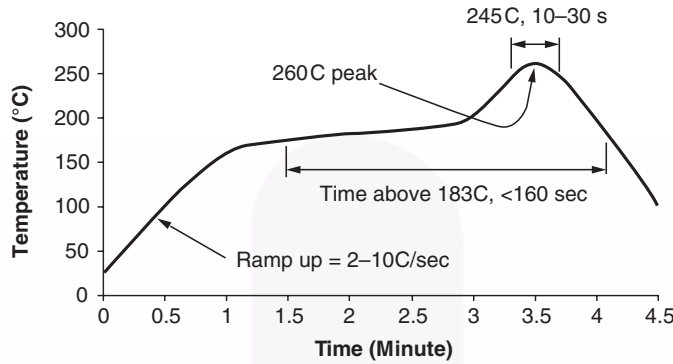

- Peak reflow temperature: 260C (package surface temperature)
- Time of temperature higher than 183C for 160 seconds or less
- One time soldering reflow is recommended

Output Power Derating

The maximum package power dissipation is 295mW. The package is limited to this level to ensure that under normal operating conditions and over extended temperature range that the semiconductor junction temperatures do not exceed 125°C. The package power is composed of three elements; the LED, static operating power of the output IC, and the power dissipated in the output power MOSFET transistors. The power rating of the output IC is 250mW. This power is divided between the static power of the integrated circuit, which is the product of I_{DD} times the power supply voltage ($V_{DD} - V_{EE}$). The maximum IC static output power is 150mW, ($V_{DD} - V_{EE}$) = 25V, I_{DD} = 6mA. This maximum condition is valid over the operational temperature range of -40°C to +100°C. Under these maximum operating conditions, the output of the power MOSFET is allowed to dissipate 100mW of power.

The absolute maximum output power dissipation versus ambient temperature is shown in Figure 12. The output driver is capable of supplying 100mW of output power over the temperature range from -40°C to 87°C. The output derates to 90mW at the absolute maximum operating temperature of 100°C.

Fig. 12 Absolute Maximum Power Dissipation vs. Ambient Temperature

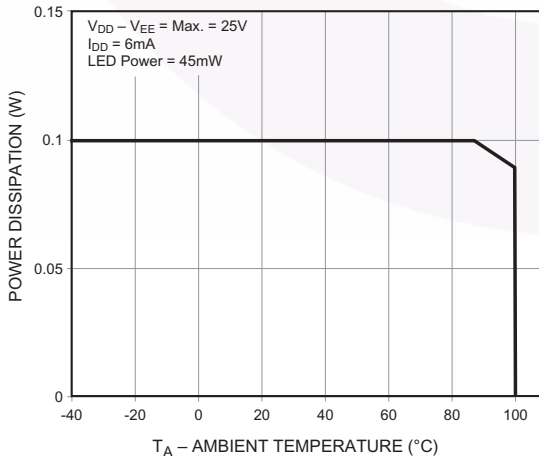

The output power is the product of the average output current squared times the output transistor's $R_{DS(ON)}$:

$$P_{O(AVG)} = I_{O(AVG)}^2 \cdot R_{DS(ON)}$$

The $I_{O(AVG)}$ is the product of the duty factor times the peak current flowing in the output. The duty factor is the ratio of the 'on' time of the output load current divided by the period of the operating frequency. An $R_{DS(ON)}$ of 2.0Ω results in an average output load current of 200mA. The load duty factor is a ratio of the average output time of the power MOSFET load circuit and period of the driving frequency.

The maximum permissible, operating frequency is determined by the load supplied to the output at its resulting output pulse width. Figure 13 shows an example of a 0.03μF gate to source capacitance with a series resistance of 8.50Ω. This reactive load results in a composite average pulse width of 1.5μs. Under this load condition it is not necessary to derate the absolute maximum output current until the frequency of operation exceeds 63kHz.

Fig. 13 Output Current Derating vs. Frequency

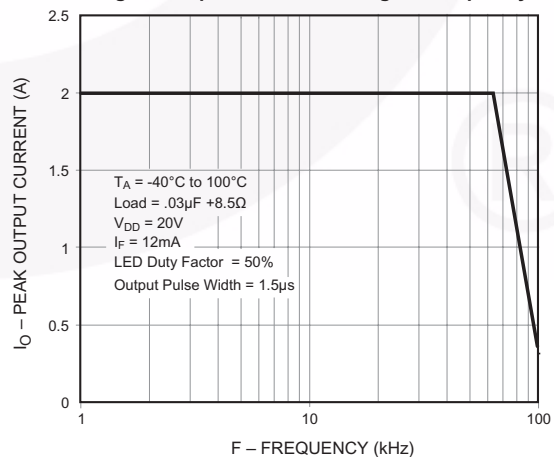

I_{OH} and I_{OL} Test Conditions

This device is tested and specified when driving a complex reactive load. The load consists of a capacitor in the series with a current limiting resistor. The capacitor represents the gate to source capacitance of a power MOSFET transistor. The test load is a $0.03\mu\text{F}$ capacitor in series with an 8.5Ω resistor. The LED test frequency is 10.0kHz with a 50% duty cycle. The combined I_{OH} and I_{OL} output load current duty factor is 0.6% at the test frequency.

Figure 14 illustrates the relationship of the LED input drive current and the device's output voltage and sourcing and sinking currents. The $0.03\mu\text{F}$ capacitor load represents the gate to source capacitance of a very large power MOSFET transistor. A single supply voltage of 20V is used in the evaluation.

Figure 15 shows the test schematic to evaluate the output voltage and sourcing and sinking capability of the device. The I_{OH} and I_{OL} are measured at the peak of their respective current pulses.

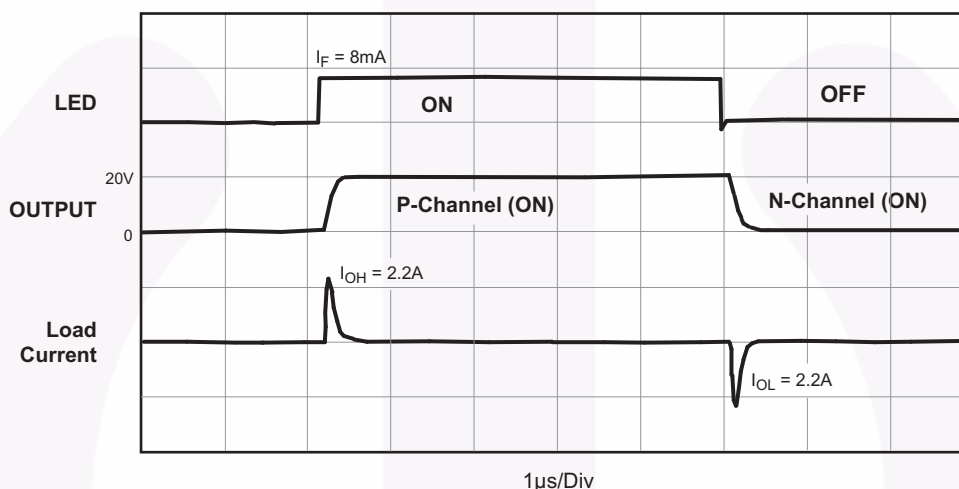

Figure 14. FOD 3180 Output Current and Output Voltage vs. LED Drive

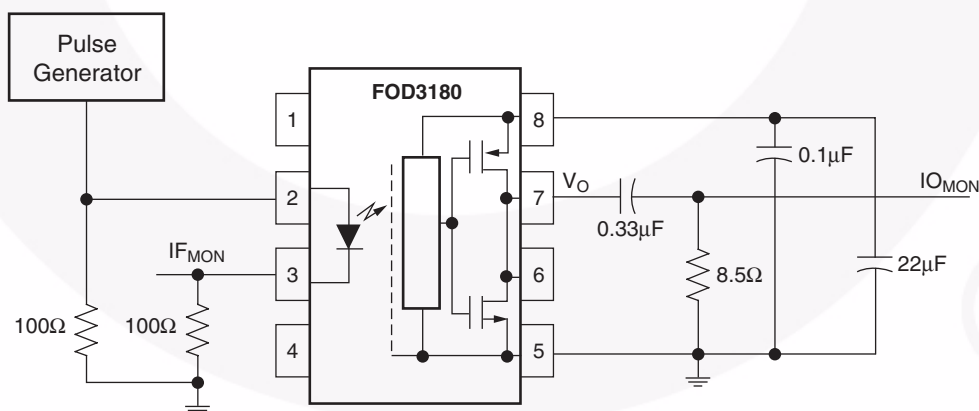
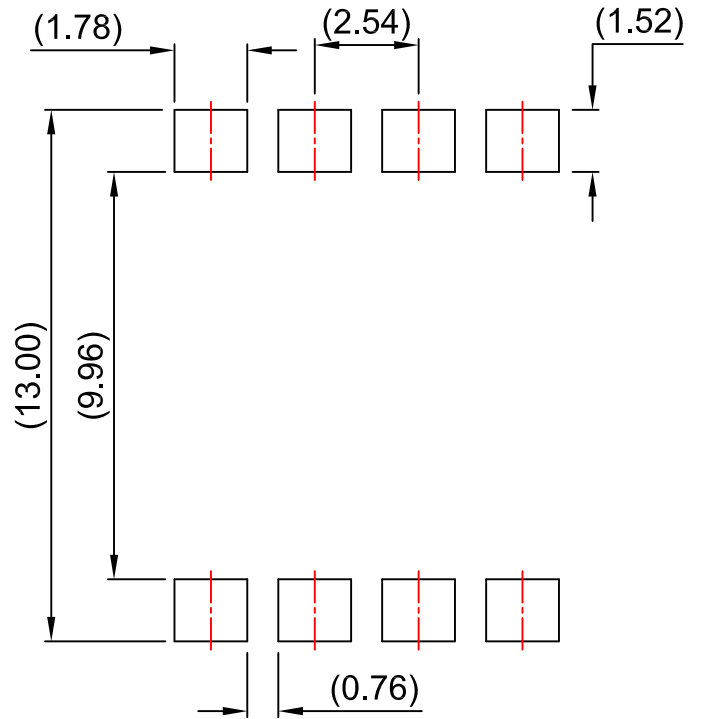
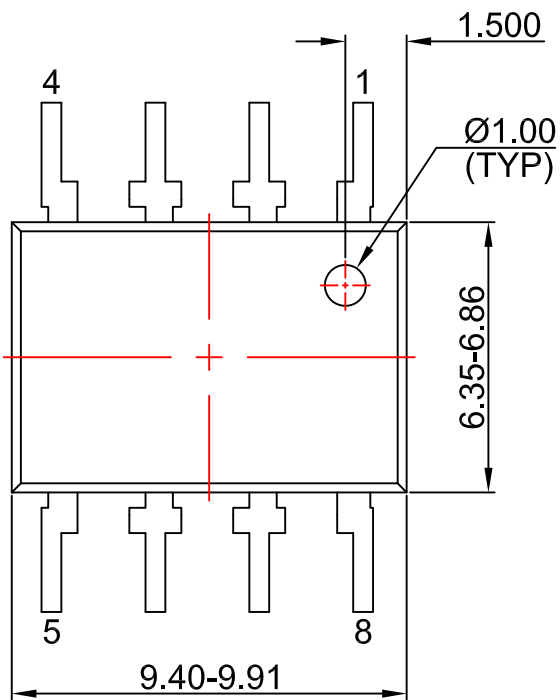
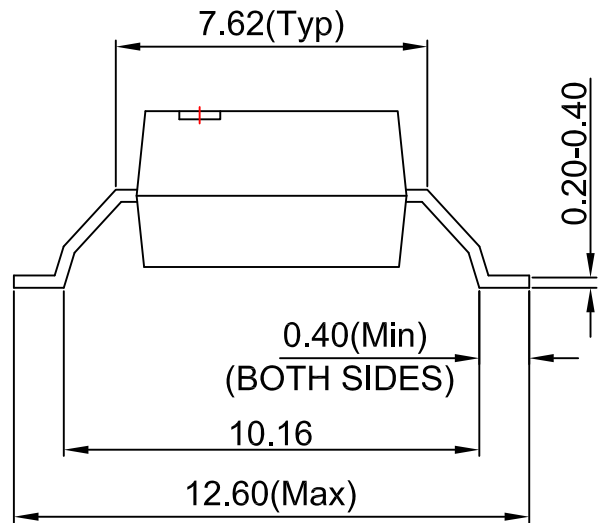
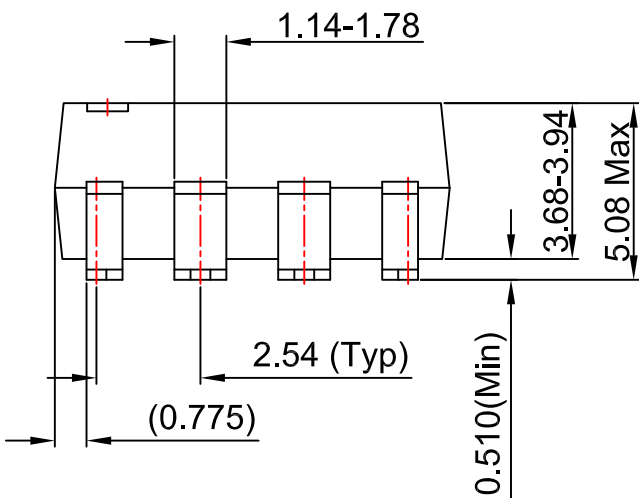

Figure 15. Test Schematic



LAND PATTERN RECOMMENDATION



NOTES:

- A) NO STANDARD APPLIES TO THIS PACKAGE
- B) ALL DIMENSIONS ARE IN MILLIMETERS.
- C) DIMENSIONS ARE EXCLUSIVE OF BURRS, MOLD FLASH, AND TIE BAR EXTRUSION
- D) DWG FILENAME AND REVISION: MKT-N08Lrev2.



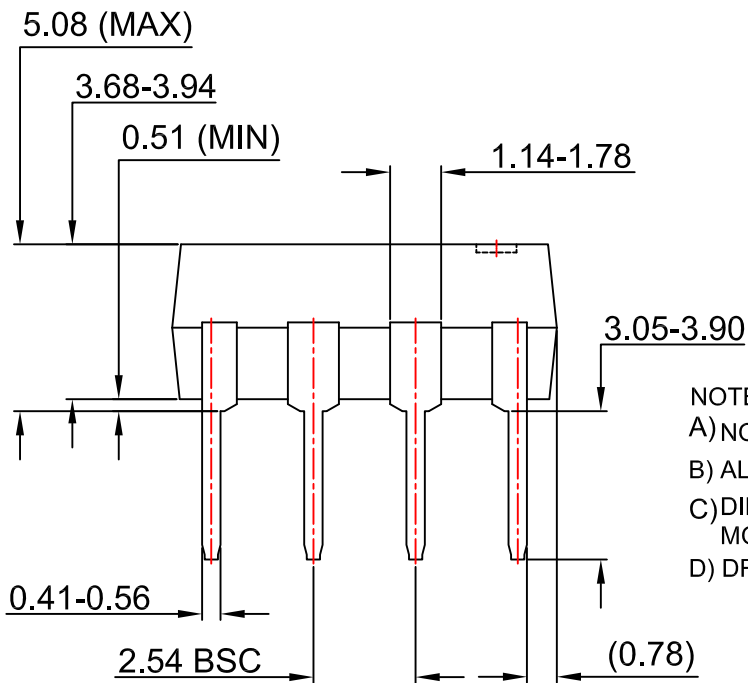
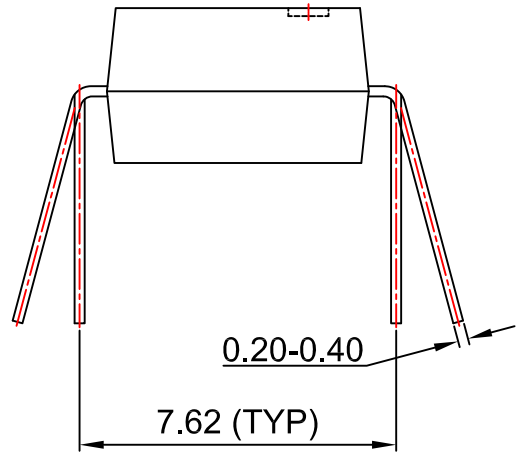
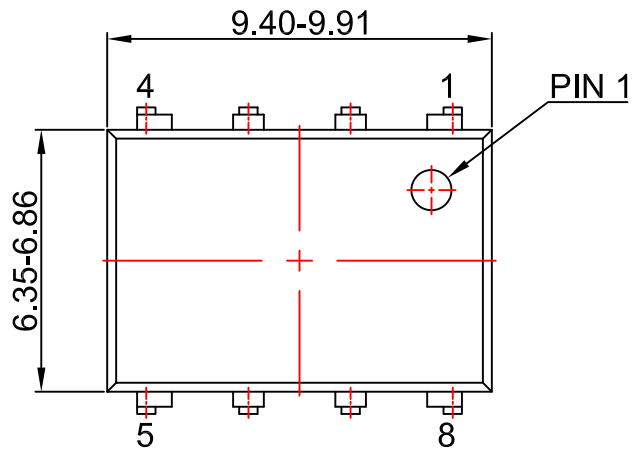

- NOTES:
- A) NO STANDARD APPLIES TO THIS PACKAGE
 - B) ALL DIMENSIONS ARE IN MILLIMETERS.
 - C) DIMENSIONS ARE EXCLUSIVE OF BURRS, MOLD FLASH, AND TIE BAR EXTRUSION
 - D) DRAWING FILENAME AND REVISION: MKT-N08GREV7



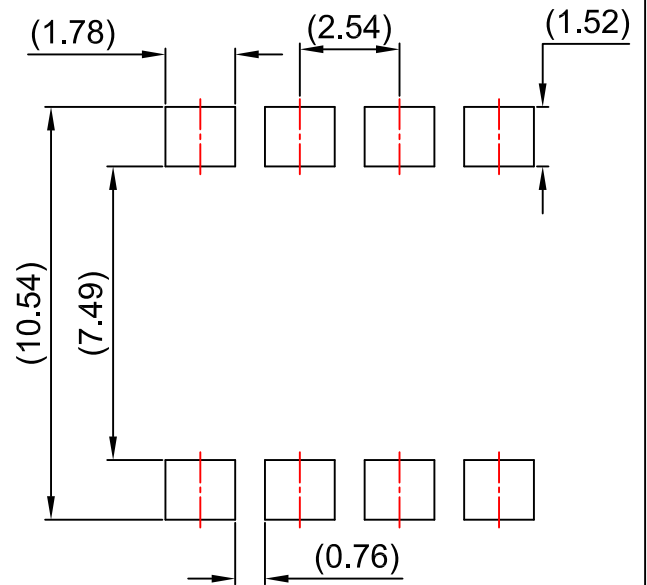
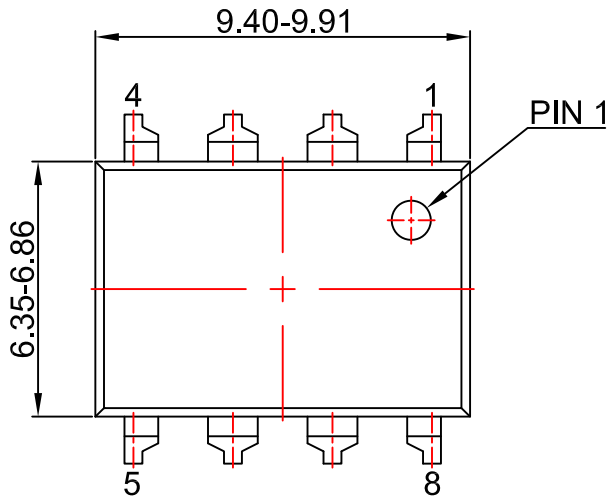

LAND PATTERN RECOMMENDATION

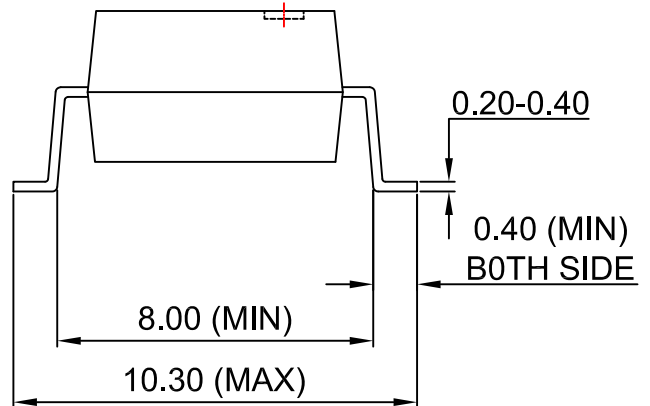
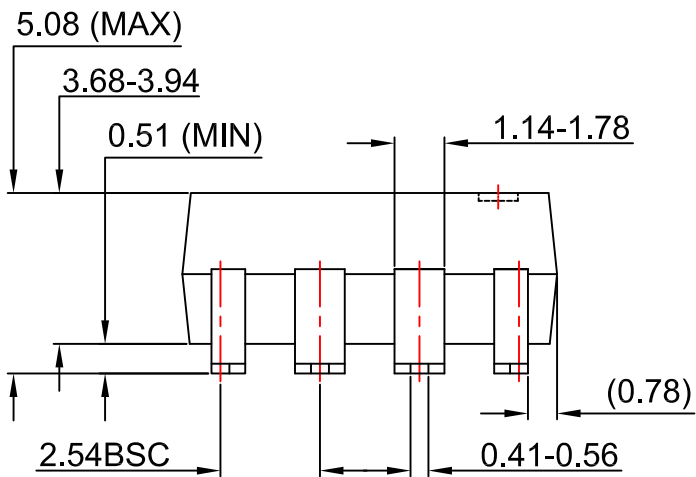

NOTES:

- A) NO STANDARD APPLIES TO THIS PACKAGE
- B) ALL DIMENSIONS ARE IN MILLIMETERS.
- C) DIMENSIONS ARE EXCLUSIVE OF BURRS, MOLD FLASH, AND TIE BAR EXTRUSION
- D) DRAWING FILENAME AND REVISION: MKT-N08Hrev7.



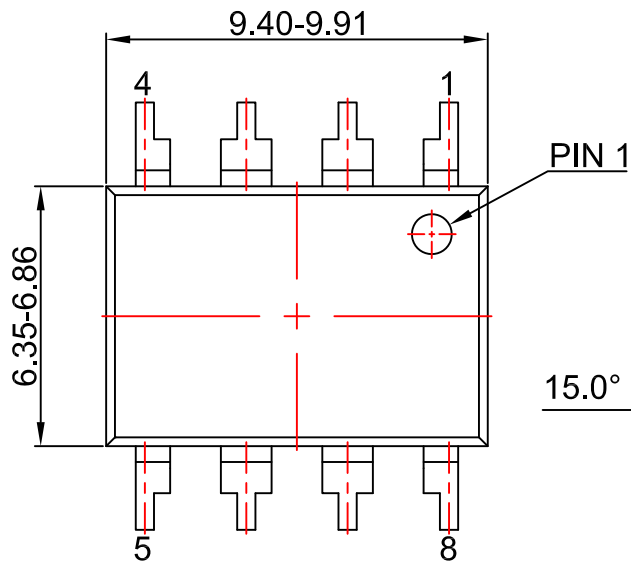

PIN 1

15.0° (MAX)

10.16 (TYP)

0.20-0.40

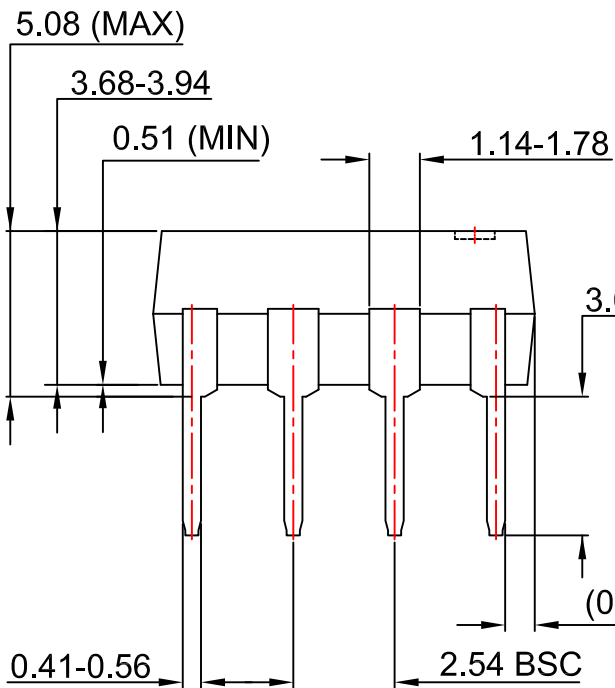

NOTES:

- A) NO STANDARD APPLIES TO THIS PACKAGE
- B) ALL DIMENSIONS ARE IN MILLIMETERS.
- C) DIMENSIONS ARE EXCLUSIVE OF BURRS, MOLD FLASH, AND TIE BAR EXTRUSION
- D) DRAWING FILENAME AND REVISION: MKT-N08REV7



ON Semiconductor and  are trademarks of Semiconductor Components Industries, LLC dba ON Semiconductor or its subsidiaries in the United States and/or other countries. ON Semiconductor owns the rights to a number of patents, trademarks, copyrights, trade secrets, and other intellectual property. A listing of ON Semiconductor's product/patent coverage may be accessed at www.onsemi.com/site/pdf/Patent-Marking.pdf. ON Semiconductor reserves the right to make changes without further notice to any products herein. ON Semiconductor makes no warranty, representation or guarantee regarding the suitability of its products for any particular purpose, nor does ON Semiconductor assume any liability arising out of the application or use of any product or circuit, and specifically disclaims any and all liability, including without limitation special, consequential or incidental damages. Buyer is responsible for its products and applications using ON Semiconductor products, including compliance with all laws, regulations and safety requirements or standards, regardless of any support or applications information provided by ON Semiconductor. "Typical" parameters which may be provided in ON Semiconductor data sheets and/or specifications can and do vary in different applications and actual performance may vary over time. All operating parameters, including "Typicals" must be validated for each customer application by customer's technical experts. ON Semiconductor does not convey any license under its patent rights nor the rights of others. ON Semiconductor products are not designed, intended, or authorized for use as a critical component in life support systems or any FDA Class 3 medical devices or medical devices with a same or similar classification in a foreign jurisdiction or any devices intended for implantation in the human body. Should Buyer purchase or use ON Semiconductor products for any such unintended or unauthorized application, Buyer shall indemnify and hold ON Semiconductor and its officers, employees, subsidiaries, affiliates, and distributors harmless against all claims, costs, damages, and expenses, and reasonable attorney fees arising out of, directly or indirectly, any claim of personal injury or death associated with such unintended or unauthorized use, even if such claim alleges that ON Semiconductor was negligent regarding the design or manufacture of the part. ON Semiconductor is an Equal Opportunity/Affirmative Action Employer. This literature is subject to all applicable copyright laws and is not for resale in any manner.

PUBLICATION ORDERING INFORMATION

LITERATURE FULFILLMENT:

Literature Distribution Center for ON Semiconductor
19521 E. 32nd Pkwy, Aurora, Colorado 80011 USA
Phone: 303-675-2175 or 800-344-3860 Toll Free USA/Canada
Fax: 303-675-2176 or 800-344-3867 Toll Free USA/Canada
Email: orderlit@onsemi.com

N. American Technical Support: 800-282-9855 Toll Free
USA/Canada
Europe, Middle East and Africa Technical Support:
Phone: 421 33 790 2910
Japan Customer Focus Center
Phone: 81-3-5817-1050

ON Semiconductor Website: www.onsemi.com
Order Literature: <http://www.onsemi.com/orderlit>
For additional information, please contact your local
Sales Representative

Looking for pricing, stock, or lifecycle information?

Click below to explore more details on WIN SOURCE:

- ⊖ [View FOD3180TSV on WIN SOURCE](#)
- ⊖ [Fairchild/ON Semiconductor Information](#)

Optimize Your Supply Chain with WIN SOURCE Solutions

- ✓ Global Sourcing Solution
- ✓ Obsolete Management
- ✓ Cost Control Management
- ✓ Shortage Management
- ✓ Alternative Solution
- ✓ Excess Inventory Management