



**THE DATASHEET OF
DS36C279TM/NOPB**



DS36C279 Low Power EIA-RS-485 Transceiver with Sleep Mode

Check for Samples: [DS36C279](#)

FEATURES

- **100% RS-485 Compliant**
 - Specified RS-485 Device Interoperation
- **Low Power CMOS Design: I_{CC} 500 μ A Max**
- **Automatic Sensing Sleep Mode**
 - Reduces I_{CC} to 10 μ A Maximum
- **Built-in Power Up/Down Glitch-Free Circuitry**
 - Permits Live Transceiver Intersection/Displacement
- **SOIC Packages**
- **Industrial Temperature Range: -40°C to $+85^{\circ}\text{C}$**
- **On-Board Thermal Shutdown Circuitry**
 - Prevents Damage to the Device in the Event of Excessive Power Dissipation
- **Wide Common Mode Range: -7V to $+12\text{V}$**
- **Receive Open Input Fail-Safe⁽¹⁾**
- **$\frac{1}{4}$ Unit Load (DS36C279): ≥ 128 Nodes**
- **$\frac{1}{2}$ Unit Load (DS36C279T): ≥ 64 Nodes**
- **ESD (Human Body Model): ≥ 2 kV**
- **Drop-In Replacement for:**
 - LTC485 MAX485 DS75176 DS3695

(1) Non-terminated, open input only

DESCRIPTION

The DS36C279 is a low power differential bus/line transceiver designed to meet the requirements of RS-485 Standard for multipoint data transmission. In addition it is compatible with TIA/EIA-422-B.

The sleep mode feature automatically puts the device in a power saving mode when both the driver and receiver are disabled.⁽²⁾ The device is ideal for use in power conscious applications where the device may be disabled for extended periods of time.

The driver and receiver outputs feature TRI-STATE capability. The driver outputs operate over the entire common mode range of -7V to $+12\text{V}$. Bus contention or fault situations that cause excessive power dissipation within the device are handled by a thermal shutdown circuit, which forces the driver outputs into a high impedance state.

The receiver incorporates a fail safe circuit which ensures a high output state when the inputs are left open.⁽³⁾

The DS36C279T is fully specified over the industrial temperature range (-40°C to $+85^{\circ}\text{C}$).

(2) Device enters sleep mode if enable conditions are held > 600 ns

(3) Non-terminated, open input only

Connection and Logic Diagram

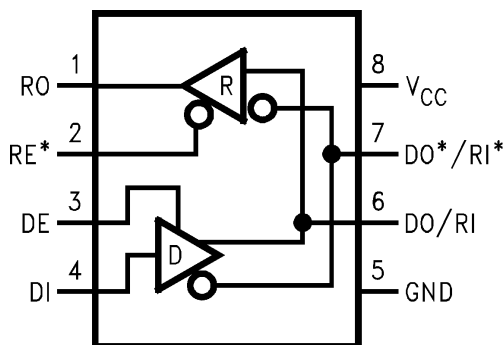

Figure 1. See Package Number D



Please be aware that an important notice concerning availability, standard warranty, and use in critical applications of Texas Instruments semiconductor products and disclaimers thereto appears at the end of this data sheet.

TRUTH TABLE

DRIVER SECTION				
RE*	DE	DI	DO/RI	DO*/RI*
X	H	H	H	L
X	H	L	L	H
X	L	X	Z	Z
RECEIVER SECTION				
RE*	DE	RI-RI*		RO
L	L	$\geq +0.2V$		H
L	L	$\leq -0.2V$		L
H	L	X		Z ⁽¹⁾
L	L	OPEN ⁽²⁾		H

- (1) Device enters sleep mode if enable conditions are held > 600 ns
(2) Non-terminated, open input only



These devices have limited built-in ESD protection. The leads should be shorted together or the device placed in conductive foam during storage or handling to prevent electrostatic damage to the MOS gates.

ABSOLUTE MAXIMUM RATINGS ⁽¹⁾⁽²⁾

Supply Voltage (V_{CC})		+12V
Input Voltage (DE, RE*, & DI)		-0.5V to ($V_{CC} + 0.5V$)
Common Mode (V_{CM})	Driver Output/Receiver Input	$\pm 15V$
Input Voltage (DO/RI, DO*/RI*)		$\pm 14V$
Receiver Output Voltage		-0.5V to ($V_{CC} + 0.5V$)
Maximum Package Power Dissipation	@ +25°C	
	D Package 1190 mW, derate	9.5 mW/°C above +25°C
Storage Temperature Range		-65°C to +150°C
Lead Temperature	(Soldering 4 sec)	+260°C

- (1) Absolute Maximum Ratings are those values beyond which the safety of the device cannot be ensured. They are not meant to imply that the devices should be operated at these limits. The table of [Electrical Characteristics](#) specifies conditions of device operation.
(2) If Military/Aerospace specified devices are required, please contact the Texas Instruments Sales Office/ Distributors for availability and specifications.

RECOMMENDED OPERATING CONDITIONS

		Min	Typ	Max	Units
Supply Voltage (V_{CC})		+4.75	+5.0	+5.25	V
Bus Voltage		-7		+12	V
Operating Free Air Temperature (T_A)	DS36C279T	-40	+25	+85	°C
	DS36C279	0	+25	+70	°C

ELECTRICAL CHARACTERISTICS⁽¹⁾⁽²⁾

Over Supply Voltage and Operating Temperature ranges, unless otherwise specified

Symbol	Parameter	Conditions	Reference	Min	Typ	Max	Units	
DIFFERENTIAL DRIVER CHARACTERISTICS								
V_{OD1}	Differential Output Voltage	$I_O = 0$ mA (No Load)	(422)	1.5		5.0	V	
V_{OD0}	Output Voltage	$I_O = 0$ mA (Output to GND)	(485)	0		5.0	V	
V_{OD0^*}	Output Voltage			0		5.0	V	
V_{OD2}	Differential Output Voltage (Termination Load)	$R_L = 50\Omega$	(422)	See Figure 2	2.0	2.8	V	
		$R_L = 27\Omega$	(485)		1.5	2.3	5.0	V
ΔV_{OD2}	Balance of V_{OD2} $ V_{OD2} - V_{OD2^*} $	$R_L = 27\Omega$ or 50Ω	See ⁽³⁾ (422, 485)	-0.2	0.1	+0.2	V	
V_{OD3}	Differential Output Voltage (Full Load)	$R1 = 54\Omega$, $R2 = 375\Omega$ $V_{TEST} = -7V$ to $+12V$	See Figure 3	1.5	2.0	5.0	V	
V_{OC}	Driver Common Mode Output Voltage	$R_L = 27\Omega$	(485)	See Figure 2	0		3.0	V
		$R_L = 50\Omega$	(422)		0		3.0	V
ΔV_{OC}	Balance of V_{OC} $ V_{OC} - V_{OC^*} $	$R_L = 27\Omega$ or $R_L = 50\Omega$	See ⁽³⁾ (422, 485)	-0.2		+0.2	V	
I_{OSD}	Driver Output Short-Circuit Current	$V_O = +12V$	(485) See Figure 5		200	+250	mA	
		$V_O = -7V$	(485)		-190	-250	mA	
RECEIVER CHARACTERISTICS								
V_{TH}	Differential Input High Threshold Voltage	$V_O = V_{OH}$, $I_O = -0.4$ mA $-7V \leq V_{CM} \leq +12V$	See ⁽⁴⁾ (422, 485)		+0.035	+0.2	V	
V_{TL}	Differential Input Low Threshold Voltage	$V_O = V_{OL}$, $I_O = 0.4$ mA $-7V \leq V_{CM} \leq +12V$		-0.2	-0.035		V	
V_{HST}	Hysteresis	$V_{CM} = 0V$	See ⁽⁵⁾		70		mV	
R_{IN}	Input Resistance	$-7V \leq V_{CM} \leq +12V$	DS36C279T	24	68		k Ω	
			DS36C279	48	68		k Ω	
I_{IN}	Line Input Current See ⁽⁶⁾	Other Input = 0V, DE = V_{IL} , RE* = V_{IL} , $V_{CC} = 4.75$ to 5.25 or 0V	DS36C279	$V_{IN} = +12V$	0	0.19	0.25	mA
				$V_{IN} = -7V$	0	-0.1	-0.2	mA
			DS36C279T	$V_{IN} = +12V$	0	0.19	0.5	mA
				$V_{IN} = -7V$	0	-0.1	-0.4	mA
I_{ING}	Line Input Current Glitch See ⁽⁶⁾	Other Input = 0V, DE = V_{IL} , RE* = V_{IL} ,	DS36C279	$V_{IN} = +12V$	0	0.19	0.25	mA
				$V_{IN} = -7V$	0	-0.1	-0.2	mA
		$V_{CC} = +3.0V$ or $0V$, $T_A = 25^\circ C$	DS36C279T	$V_{IN} = +12V$	0	0.19	0.5	mA
				$V_{IN} = -7V$	0	-0.1	-0.4	mA
I_B	Input Balance Test	$RS = 500\Omega$	(422) See ⁽⁷⁾			± 400	mV	
V_{OH}	High Level Output Voltage	$I_{OH} = -4$ mA, $V_{ID} = +0.2V$	RO See Figure 12	3.5	4.6		V	
V_{OL}	Low Level Output Voltage	$I_{OL} = +4$ mA, $V_{ID} = -0.2V$			0.3	0.5	V	
I_{OSR}	Short Circuit Current	$V_O = GND$	RO	7	35	85	mA	
I_{OZR}	TRI-STATE Leakage Current	$V_O = 0.4V$ to $2.4V$				± 1	μA	

- (1) Current into device pins is defined as positive. Current out of device pins is defined as negative. All voltages are referenced to ground except V_{OD1} and V_{OD2} .
- (2) All typicals are given for: $V_{CC} = +5.0V$, $T_A = +25^\circ C$.
- (3) Delta $|V_{OD2}|$ and Delta $|V_{OC}|$ are changes in magnitude of V_{OD2} and V_{OC} , respectively, that occur when input changes state.
- (4) Threshold parameter limits specified as an algebraic value rather than by magnitude.
- (5) Hysteresis defined as $V_{HST} = V_{TH} - V_{TL}$.
- (6) I_{IN} includes the receiver input current and driver TRI-STATE leakage current.
- (7) For complete details of test, see RS-485.

ELECTRICAL CHARACTERISTICS⁽¹⁾⁽²⁾ (continued)

Over Supply Voltage and Operating Temperature ranges, unless otherwise specified

Symbol	Parameter	Conditions	Reference	Min	Typ	Max	Units	
DEVICE CHARACTERISTICS								
V_{IH}	High Level Input Voltage		DE, RE*, DI	2.0		V_{CC}	V	
V_{IL}	Low Level Input Voltage			GND		0.8	V	
I_{IH}	High Level Input Current	$V_{IH} = V_{CC}$				2	μA	
I_{IL}	Low Level Input Current	$V_{CC} = 5V$		$V_{IL} = 0V$			-2	μA
		$V_{CC} = +3.0V$				-2	μA	
I_{CC}	Power Supply Current (No Load)	Driver and Receiver ON		V_{CC}		200	500	μA
I_{CCR}		Driver OFF, Receiver ON				200	500	μA
I_{CCD}		Driver ON, Receiver OFF				200	500	μA
I_{CCX}		Sleep Mode				0.2	10	μA

SWITCHING CHARACTERISTICS⁽¹⁾⁽²⁾

Over Supply Voltage and Operating Temperature ranges, unless otherwise specified

Symbol	Parameter	Conditions	Reference	Min	Typ	Max	Units
DRIVER CHARACTERISTICS							
t_{PHLD}	Differential Propagation Delay High to Low	$R_L = 54\Omega, C_L = 100\text{ pF}$	See Figure 6 and Figure 7	10	39	80	ns
t_{PLHD}	Differential Propagation Delay Low to High			10	40	80	ns
t_{SKD}	Differential Skew $ t_{PHLD} - t_{PLHD} $			0	1	10	ns
t_r	Rise Time			3	25	50	ns
t_f	Fall Time			3	25	50	ns
t_{PHZ}	Disable Time High to Z	$C_L = 15\text{ pF}$ $RE^* = L$	See Figure 8 and Figure 9		80	200	ns
t_{PLZ}	Disable Time Low to Z				80	200	ns
t_{PZH}	Enable Time Z to High	$C_L = 100\text{ pF}$ $RE^* = L$	See Figure 8 and Figure 9		50	200	ns
t_{PZL}	Enable Time Z to Low				65	200	ns
t_{PSH}	Driver Enable from Sleep Mode to Output High	$C_L = 100\text{ pF}$ See ⁽³⁾	See Figure 8 and Figure 9	70	98	250	ns
t_{PSL}	Driver Enable from Sleep Mode to Output Low	$C_L = 100\text{ pF}$ See ⁽³⁾	See Figure 10 and Figure 11	70	98	250	ns
RECEIVER CHARACTERISTICS							
t_{PHL}	Propagation Delay High to Low	$C_L = 15\text{ pF}$	See Figure 13 and Figure 14	30	210	400	ns
t_{PLH}	Propagation Delay Low to High			30	190	400	ns
t_{SK}	Skew, $ t_{PHL} - t_{PLH} $			0	20	50	ns
t_{PLZ}	Output Disable Time	$C_L = 15\text{ pF DE} = H$	See Figure 15, Figure 16 and Figure 17		50	150	ns
t_{PHZ}					55	150	ns
t_{PZL}	Output Enable Time				40	150	ns
t_{PZH}					45	150	ns
t_{PSH}	Receiver Enable from Sleep Mode to Output High	$C_L = 15\text{ pF}$ See ⁽³⁾	See Figure 15 and Figure 17	70	97	250	ns
t_{PSL}	Receiver Enable from Sleep Mode to Output Low	$C_L = 15\text{ pF}$ See ⁽³⁾	See Figure 15 and Figure 16	70	95	250	ns

(1) All typicals are given for: $V_{CC} = +5.0V, T_A = +25^\circ C$.

(2) C_L includes probe and jig capacitance.

(3) For enable from sleep mode delays $DE = L$ and $RE^* = H$ for greater than 600 ns prior to test (device is in sleep mode).

PARAMETER MEASUREMENT INFORMATION

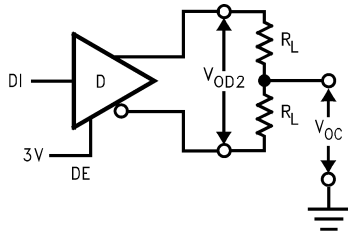

Figure 2. Driver V_{OD2} and V_{OC}

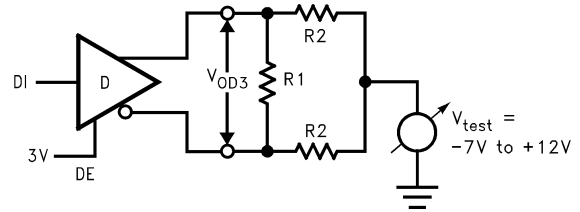

Figure 3. Driver V_{OD3}

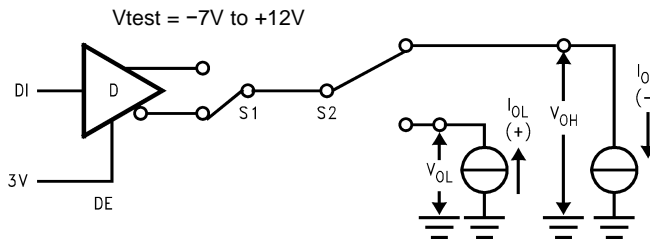

Figure 4. Driver V_{OH} and V_{OL}

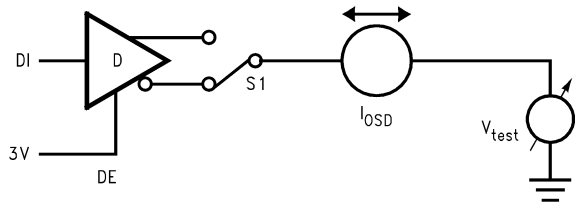

Figure 5. Driver I_{OD3}

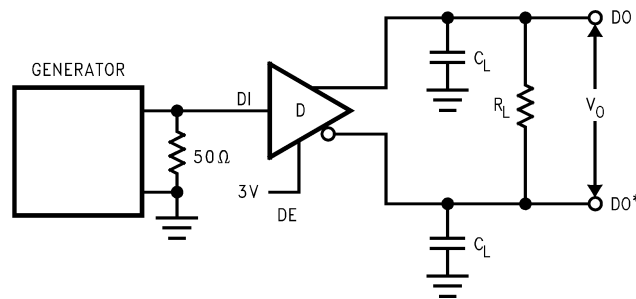

Figure 6. Driver Differential Propagation Delay Test Circuit

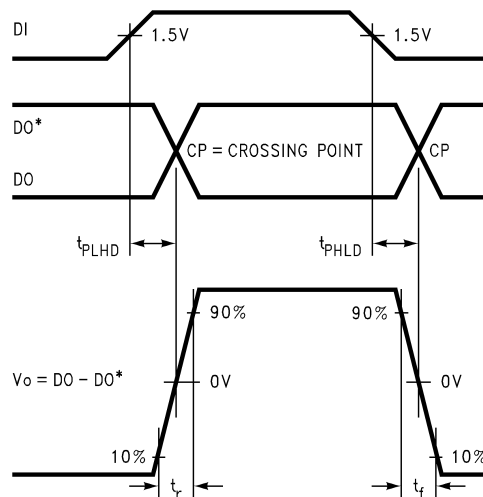

Figure 7. Driver Differential Propagation Delays and Differential Rise and Fall Times

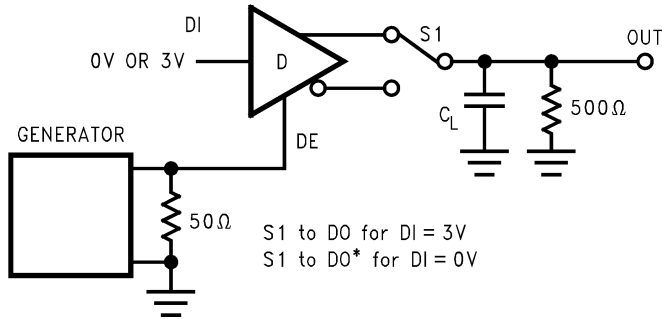

Figure 8. TRI-STATE and Sleep Mode Test Circuit (t_{PZH} , t_{PSH} , t_{PHZ})

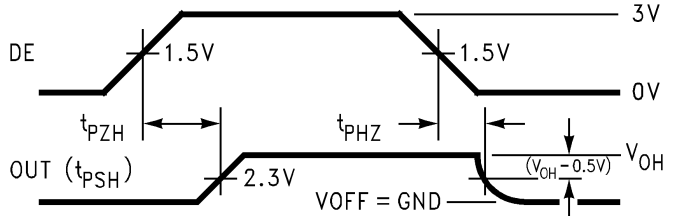

Figure 9. TRI-STATE and Sleep Mode Waveforms (t_{PZH} , t_{PSH} , t_{PHZ})

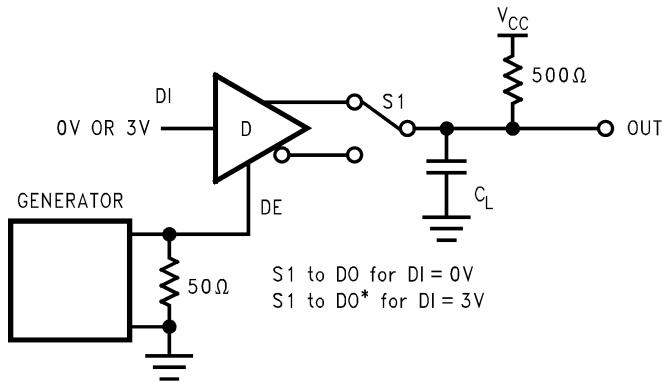

Figure 10. TRI-STATE and Sleep Mode Test Circuit (t_{PZL} , t_{PSL} , t_{PLZ})

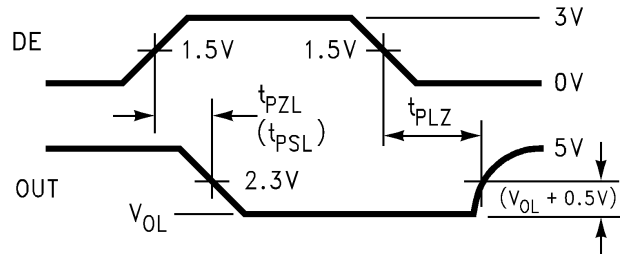

Figure 11. TRI-STATE and Sleep Mode Waveforms (t_{PZL} , t_{PSL} , t_{PLZ})

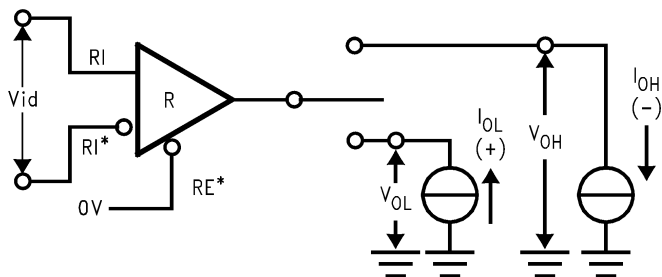

Figure 12. Receiver V_{OH} and V_{OL}

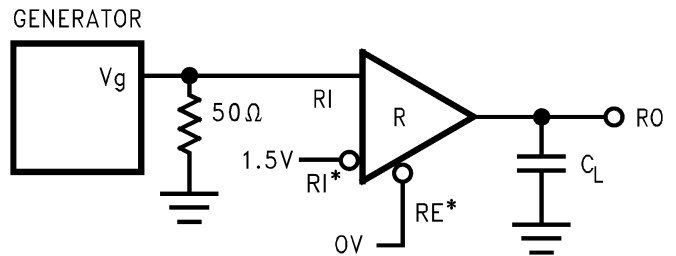

Figure 13. Receiver Differential Propagation Delay Test Circuit

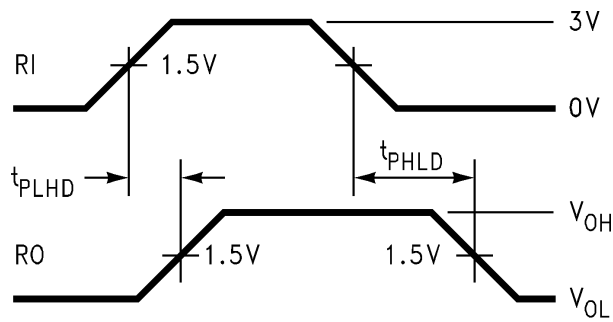

Figure 14. Receiver Differential Propagation Delay Waveforms

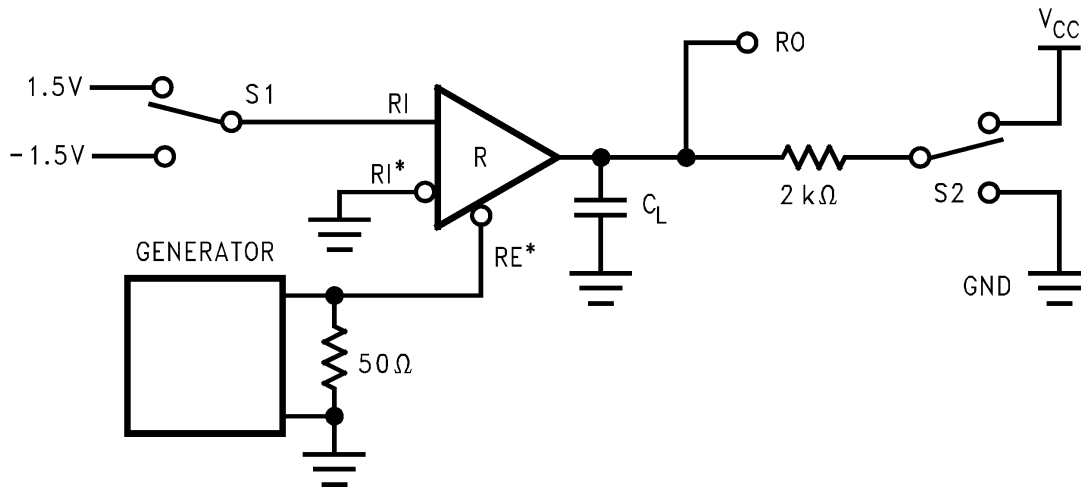

Figure 15. Receiver TRI-STATE and Sleep Mode Test Circuit

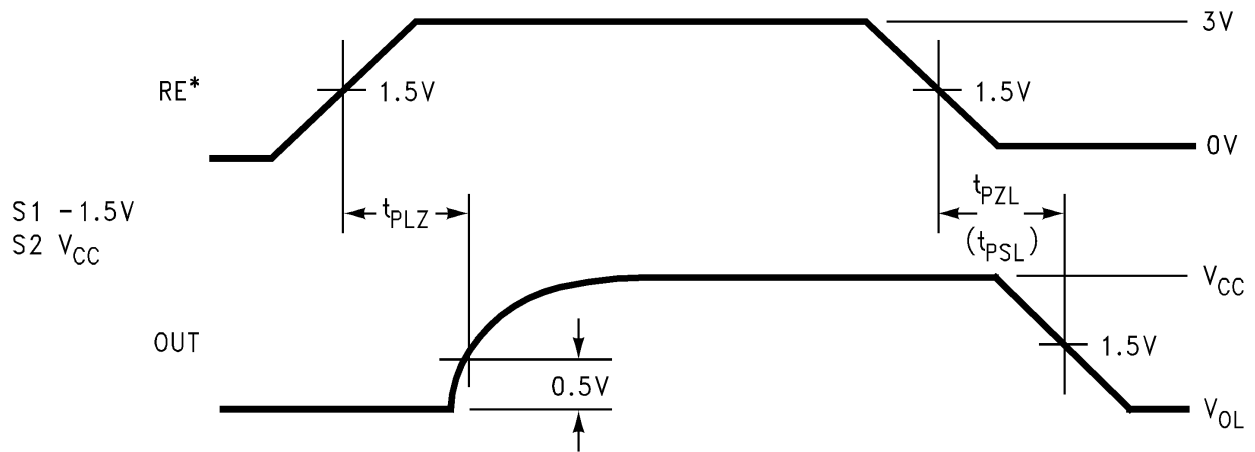

Figure 16. Receiver Enable and Disable Waveforms (t_{PLZ} , t_{PZL} , t_{PSL})

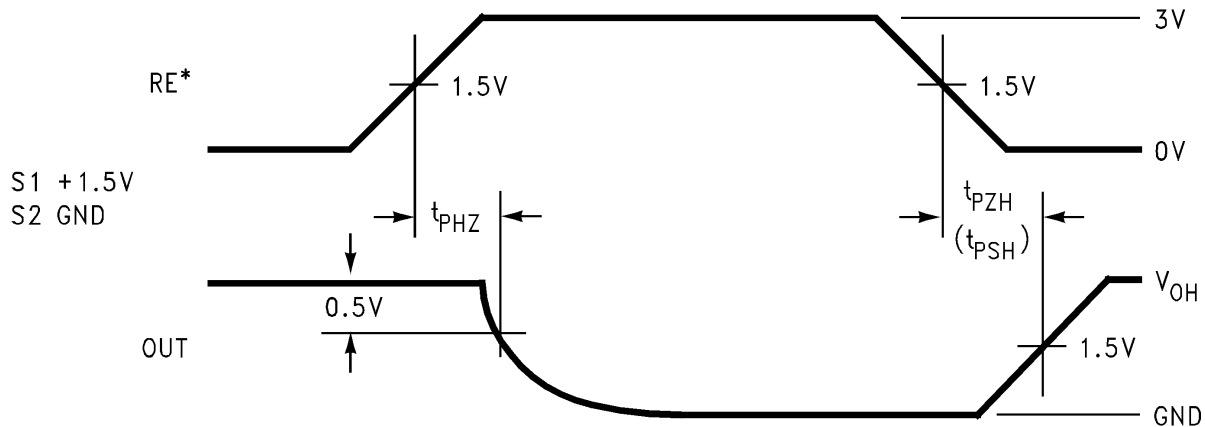

Figure 17. Receiver Enable and Disable Waveforms (t_{PHZ} , t_{PZH} , t_{PSH})

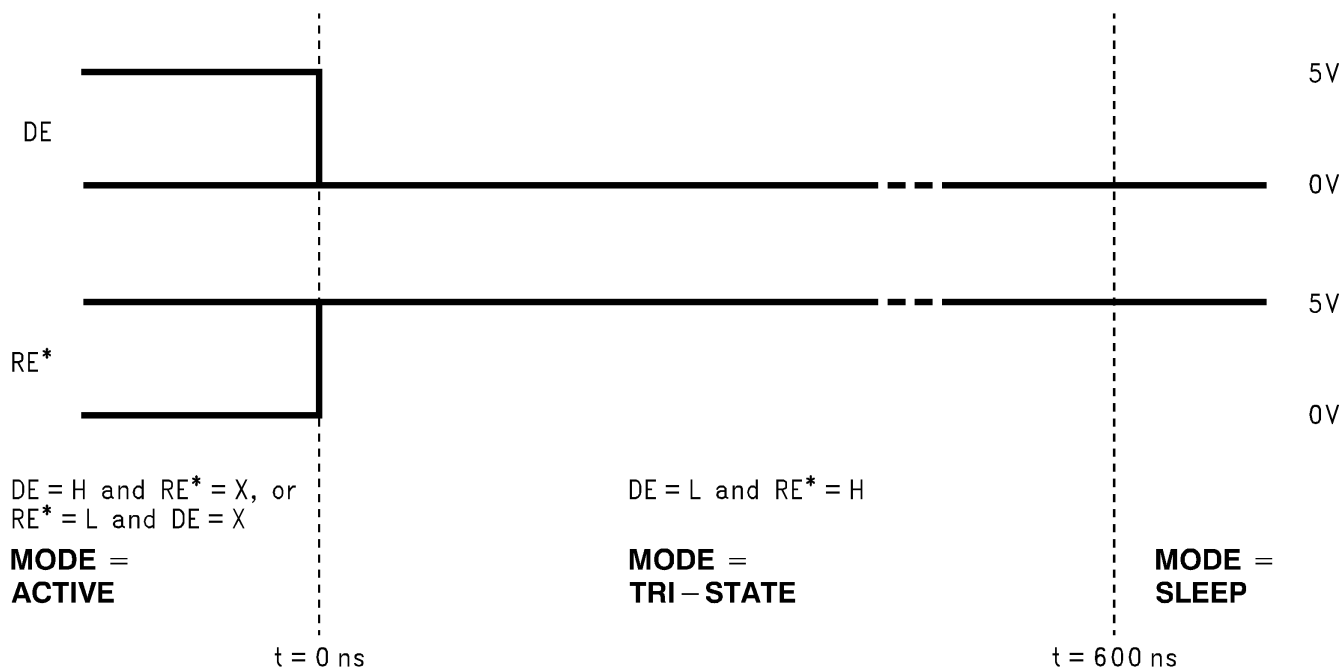

Figure 18. Entering Sleep Mode Conditions

TYPICAL APPLICATION INFORMATION

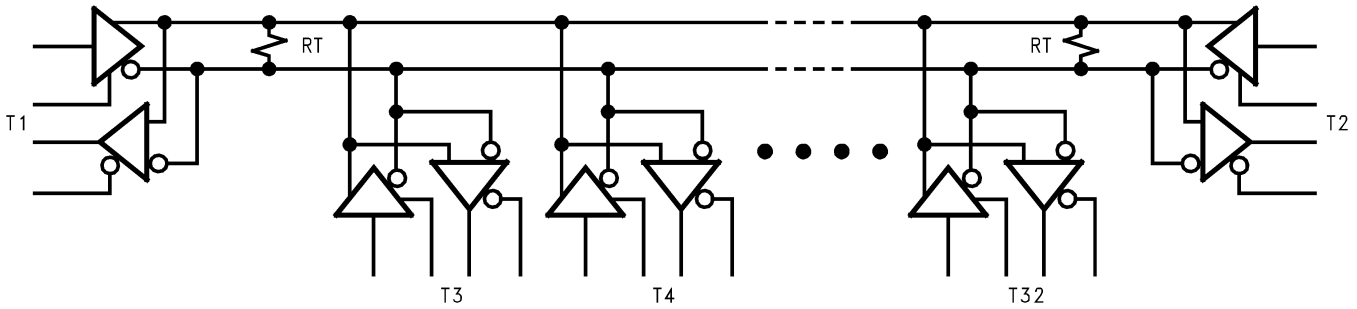

Figure 19. Typical RS-485 Bus Interface

Table 1. DEVICE PIN DESCRIPTIONS

Pin No.	Name	Description
1	RO	Receiver Output: When RE (Receiver Enable) is LOW, the receiver is enabled (ON), if DO/RI \geq DO*/RI* by 200 mV, RO will be HIGH. If DO/RI \leq DO*/RI* by 200 mV, RO will be LOW. Additionally RO will be HIGH for OPEN (Non-terminated) Inputs.
2	RE*	Receiver Output Enable: When RE* is LOW the receiver output is enabled. When RE* is HIGH, the receiver output is in TRI-STATE (OFF). When RE* is HIGH and DE is LOW, the device will enter a low-current sleep mode after 600 ns.
3	DE	Driver Output Enable: When DE is HIGH, the driver outputs are enabled. When DE is LOW, the driver outputs are in TRI-STATE (OFF). When RE* is HIGH and DE is LOW, the device will enter a low-current sleep mode after 600 ns.
4	DI	Driver Input: When DE (Driver Enable) is HIGH, the driver is enabled, if DI is LOW, then DO/RI will be LOW and DO*/RI* will be HIGH. If DI is HIGH, then DO/RI is HIGH and DO*/RI* is LOW.
5	GND	Ground Connection.
6	DO/RI	Driver Output/Receiver Input, 485 Bus Pin.
7	DO*/RI*	Driver Output/Receiver Input, 485 Bus Pin.
8	V _{CC}	Positive Power Supply Connection: Recommended operating range for V _{CC} is +4.75V to +5.25V.

UNIT LOAD

A unit load for an RS-485 receiver is defined by the input current versus the input voltage curve. The gray shaded region is the defined operating range from $-7V$ to $+12V$. The top border extending from $-3V$ at 0 mA to $+12V$ at $+1\text{ mA}$ is defined as one unit load. Likewise, the bottom border extending from $+5V$ at 0 mA to $-7V$ at -0.8 mA is also defined as one unit load (see Figure 20). An RS-485 driver is capable of driving up to 32 unit loads. This allows up to 32 nodes on a single bus. Although sufficient for many applications, it is sometimes desirable to have even more nodes. For example, an aircraft that has 32 rows with 4 seats per row would benefit from having 128 nodes on one bus. This would allow signals to be transferred to and from each individual seat to 1 main station. Usually there is one or two less seats in the last row of the aircraft near the restrooms and food storage area. This frees the node for the main station.

The DS36C278, the DS36C279, and the DS36C280 all have $\frac{1}{2}$ unit load and $\frac{1}{4}$ unit load (UL) options available. These devices will allow up to 64 nodes or 128 nodes specified over temperature depending upon which option is selected. The $\frac{1}{2}$ UL option is available in industrial temperature and the $\frac{1}{4}$ UL is available in commercial temperature.

First, for a $\frac{1}{2}$ UL device the top and bottom borders shown in Figure 20 are scaled. Both 0 mA reference points at $+5V$ and $-3V$ stay the same. The other reference points are $+12V$ at $+0.5\text{ mA}$ for the top border and $-7V$ at -0.4 mA for the bottom border (see Figure 20). Second, for a $\frac{1}{4}$ UL device the top and bottom borders shown in Figure 20 are scaled also. Again, both 0 mA reference points at $+5V$ and $-3V$ stay the same. The other reference points are $+12V$ at $+0.25\text{ mA}$ for the top border and $-7V$ at -0.2 mA for the bottom border (see Figure 20).

The advantage of the ½ UL and ¼ UL devices is the increased number of nodes on one bus. In a single master multi-slave type of application where the number of slaves exceeds 32, the DS36C278/279/280 may save in the cost of extra devices like repeaters, extra media like cable, and/or extra components like resistors.

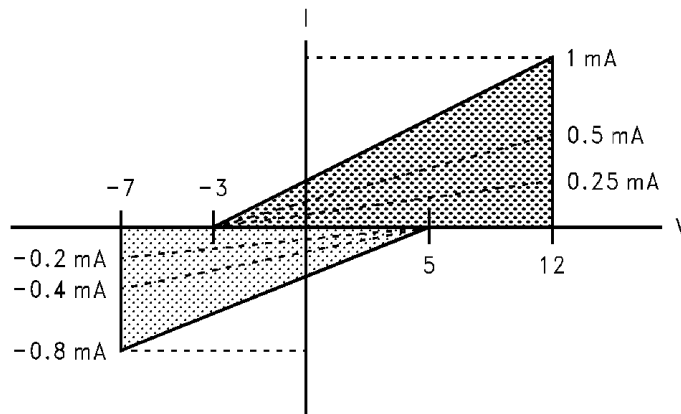

Figure 20. Input Current vs Input Voltage Operating Range

The DS36C279 and DS36C280 have an additional feature which offers more advantages. The DS36C279 has an automatic sleep mode function for power conscious applications. The DS36C280 has a slew rate control for EMI conscious applications. Refer to the sleep mode and slew rate control portion of the application information section in the corresponding datasheet for more information on these features.

SLEEP MODE

The DS36C279 features an automatic shutdown mode that allows the device to save power when not transmitting data. Since the shutdown mode is automatic, no external components are required. It may be used as little or as much as the application requires. The more the feature is utilized, the more power it saves.

The sleep mode is automatically entered when both the driver and receiver are disabled. This occurs when both the DE pin is asserted to a logic low and the RE* pin is asserted to a logic high. Once both pins are asserted the device will enter sleep mode typically in 50 ns. The DS36C279 is ensured to go into sleep mode within 600 ns after both pins are asserted. The device wakes up (comes out of sleep mode) when either the DE pin is asserted to a logic high and/or the RE* pin is asserted to a logic low. After the device enters sleep mode it will take longer for the device to wake up than it does for the device to enable from TRI-STATE. Refer to data specifications t_{PSL} and t_{PSH} and compare with t_{PZL} and t_{PZH} for timing differences.

The benefit of the DS36C279 is definitely its power savings. When active the device has a maximum I_{CC} of 500 μ A. When in sleep mode the device has a maximum I_{CC} of only 10 μ A, which is 50 times less power than when active. The I_{CC} when the device is active is already very low but when in sleep mode the I_{CC} is ultra low.

REVISION HISTORY

Changes from Revision A (April 2013) to Revision B	Page
• Changed layout of National Data Sheet to TI format	11

PACKAGING INFORMATION

Orderable Device	Status (1)	Package Type	Package Drawing	Pins	Package Qty	Eco Plan (2)	Lead/Ball Finish (6)	MSL Peak Temp (3)	Op Temp (°C)	Device Marking (4/5)	Samples
DS36C279M/NOPB	NRND	SOIC	D	8	95	Green (RoHS & no Sb/Br)	CU SN	Level-1-260C-UNLIM	-40 to 85	36C27 9M	
DS36C279MX/NOPB	NRND	SOIC	D	8	2500	Green (RoHS & no Sb/Br)	CU SN	Level-1-260C-UNLIM	-40 to 85	36C27 9M	

(1) The marketing status values are defined as follows:

ACTIVE: Product device recommended for new designs.

LIFEBUY: TI has announced that the device will be discontinued, and a lifetime-buy period is in effect.

NRND: Not recommended for new designs. Device is in production to support existing customers, but TI does not recommend using this part in a new design.

PREVIEW: Device has been announced but is not in production. Samples may or may not be available.

OBSOLETE: TI has discontinued the production of the device.

(2) **RoHS:** TI defines "RoHS" to mean semiconductor products that are compliant with the current EU RoHS requirements for all 10 RoHS substances, including the requirement that RoHS substance do not exceed 0.1% by weight in homogeneous materials. Where designed to be soldered at high temperatures, "RoHS" products are suitable for use in specified lead-free processes. TI may reference these types of products as "Pb-Free".

RoHS Exempt: TI defines "RoHS Exempt" to mean products that contain lead but are compliant with EU RoHS pursuant to a specific EU RoHS exemption.

Green: TI defines "Green" to mean the content of Chlorine (Cl) and Bromine (Br) based flame retardants meet JS709B low halogen requirements of <=1000ppm threshold. Antimony trioxide based flame retardants must also meet the <=1000ppm threshold requirement.

(3) MSL, Peak Temp. - The Moisture Sensitivity Level rating according to the JEDEC industry standard classifications, and peak solder temperature.

(4) There may be additional marking, which relates to the logo, the lot trace code information, or the environmental category on the device.

(5) Multiple Device Markings will be inside parentheses. Only one Device Marking contained in parentheses and separated by a "~" will appear on a device. If a line is indented then it is a continuation of the previous line and the two combined represent the entire Device Marking for that device.

(6) Lead/Ball Finish - Orderable Devices may have multiple material finish options. Finish options are separated by a vertical ruled line. Lead/Ball Finish values may wrap to two lines if the finish value exceeds the maximum column width.

Important Information and Disclaimer:The information provided on this page represents TI's knowledge and belief as of the date that it is provided. TI bases its knowledge and belief on information provided by third parties, and makes no representation or warranty as to the accuracy of such information. Efforts are underway to better integrate information from third parties. TI has taken and continues to take reasonable steps to provide representative and accurate information but may not have conducted destructive testing or chemical analysis on incoming materials and chemicals. TI and TI suppliers consider certain information to be proprietary, and thus CAS numbers and other limited information may not be available for release.

In no event shall TI's liability arising out of such information exceed the total purchase price of the TI part(s) at issue in this document sold by TI to Customer on an annual basis.

IMPORTANT NOTICE

Texas Instruments Incorporated (TI) reserves the right to make corrections, enhancements, improvements and other changes to its semiconductor products and services per JESD46, latest issue, and to discontinue any product or service per JESD48, latest issue. Buyers should obtain the latest relevant information before placing orders and should verify that such information is current and complete.

TI's published terms of sale for semiconductor products (<http://www.ti.com/sc/docs/stdterms.htm>) apply to the sale of packaged integrated circuit products that TI has qualified and released to market. Additional terms may apply to the use or sale of other types of TI products and services.

Reproduction of significant portions of TI information in TI data sheets is permissible only if reproduction is without alteration and is accompanied by all associated warranties, conditions, limitations, and notices. TI is not responsible or liable for such reproduced documentation. Information of third parties may be subject to additional restrictions. Resale of TI products or services with statements different from or beyond the parameters stated by TI for that product or service voids all express and any implied warranties for the associated TI product or service and is an unfair and deceptive business practice. TI is not responsible or liable for any such statements.

Buyers and others who are developing systems that incorporate TI products (collectively, "Designers") understand and agree that Designers remain responsible for using their independent analysis, evaluation and judgment in designing their applications and that Designers have full and exclusive responsibility to assure the safety of Designers' applications and compliance of their applications (and of all TI products used in or for Designers' applications) with all applicable regulations, laws and other applicable requirements. Designer represents that, with respect to their applications, Designer has all the necessary expertise to create and implement safeguards that (1) anticipate dangerous consequences of failures, (2) monitor failures and their consequences, and (3) lessen the likelihood of failures that might cause harm and take appropriate actions. Designer agrees that prior to using or distributing any applications that include TI products, Designer will thoroughly test such applications and the functionality of such TI products as used in such applications.

TI's provision of technical, application or other design advice, quality characterization, reliability data or other services or information, including, but not limited to, reference designs and materials relating to evaluation modules, (collectively, "TI Resources") are intended to assist designers who are developing applications that incorporate TI products; by downloading, accessing or using TI Resources in any way, Designer (individually or, if Designer is acting on behalf of a company, Designer's company) agrees to use any particular TI Resource solely for this purpose and subject to the terms of this Notice.

TI's provision of TI Resources does not expand or otherwise alter TI's applicable published warranties or warranty disclaimers for TI products, and no additional obligations or liabilities arise from TI providing such TI Resources. TI reserves the right to make corrections, enhancements, improvements and other changes to its TI Resources. TI has not conducted any testing other than that specifically described in the published documentation for a particular TI Resource.

Designer is authorized to use, copy and modify any individual TI Resource only in connection with the development of applications that include the TI product(s) identified in such TI Resource. NO OTHER LICENSE, EXPRESS OR IMPLIED, BY ESTOPPEL OR OTHERWISE TO ANY OTHER TI INTELLECTUAL PROPERTY RIGHT, AND NO LICENSE TO ANY TECHNOLOGY OR INTELLECTUAL PROPERTY RIGHT OF TI OR ANY THIRD PARTY IS GRANTED HEREIN, including but not limited to any patent right, copyright, mask work right, or other intellectual property right relating to any combination, machine, or process in which TI products or services are used. Information regarding or referencing third-party products or services does not constitute a license to use such products or services, or a warranty or endorsement thereof. Use of TI Resources may require a license from a third party under the patents or other intellectual property of the third party, or a license from TI under the patents or other intellectual property of TI.

TI RESOURCES ARE PROVIDED "AS IS" AND WITH ALL FAULTS. TI DISCLAIMS ALL OTHER WARRANTIES OR REPRESENTATIONS, EXPRESS OR IMPLIED, REGARDING RESOURCES OR USE THEREOF, INCLUDING BUT NOT LIMITED TO ACCURACY OR COMPLETENESS, TITLE, ANY EPIDEMIC FAILURE WARRANTY AND ANY IMPLIED WARRANTIES OF MERCHANTABILITY, FITNESS FOR A PARTICULAR PURPOSE, AND NON-INFRINGEMENT OF ANY THIRD PARTY INTELLECTUAL PROPERTY RIGHTS. TI SHALL NOT BE LIABLE FOR AND SHALL NOT DEFEND OR INDEMNIFY DESIGNER AGAINST ANY CLAIM, INCLUDING BUT NOT LIMITED TO ANY INFRINGEMENT CLAIM THAT RELATES TO OR IS BASED ON ANY COMBINATION OF PRODUCTS EVEN IF DESCRIBED IN TI RESOURCES OR OTHERWISE. IN NO EVENT SHALL TI BE LIABLE FOR ANY ACTUAL, DIRECT, SPECIAL, COLLATERAL, INDIRECT, PUNITIVE, INCIDENTAL, CONSEQUENTIAL OR EXEMPLARY DAMAGES IN CONNECTION WITH OR ARISING OUT OF TI RESOURCES OR USE THEREOF, AND REGARDLESS OF WHETHER TI HAS BEEN ADVISED OF THE POSSIBILITY OF SUCH DAMAGES.

Unless TI has explicitly designated an individual product as meeting the requirements of a particular industry standard (e.g., ISO/TS 16949 and ISO 26262), TI is not responsible for any failure to meet such industry standard requirements.

Where TI specifically promotes products as facilitating functional safety or as compliant with industry functional safety standards, such products are intended to help enable customers to design and create their own applications that meet applicable functional safety standards and requirements. Using products in an application does not by itself establish any safety features in the application. Designers must ensure compliance with safety-related requirements and standards applicable to their applications. Designer may not use any TI products in life-critical medical equipment unless authorized officers of the parties have executed a special contract specifically governing such use. Life-critical medical equipment is medical equipment where failure of such equipment would cause serious bodily injury or death (e.g., life support, pacemakers, defibrillators, heart pumps, neurostimulators, and implantables). Such equipment includes, without limitation, all medical devices identified by the U.S. Food and Drug Administration as Class III devices and equivalent classifications outside the U.S.

TI may expressly designate certain products as completing a particular qualification (e.g., Q100, Military Grade, or Enhanced Product). Designers agree that it has the necessary expertise to select the product with the appropriate qualification designation for their applications and that proper product selection is at Designers' own risk. Designers are solely responsible for compliance with all legal and regulatory requirements in connection with such selection.

Designer will fully indemnify TI and its representatives against any damages, costs, losses, and/or liabilities arising out of Designer's non-compliance with the terms and provisions of this Notice.

Looking for pricing, stock, or lifecycle information?

Click below to explore more details on WIN SOURCE:

 [View DS36C279TM/NOPB on WIN SOURCE](#)

 [Texas Instruments](#) Information

Optimize Your Supply Chain with WIN SOURCE Solutions

-  Global Sourcing Solution
-  Obsolete Management
-  Cost Control Management
-  Shortage Management
-  Alternative Solution
-  Excess Inventory Management