



THE DATASHEET OF LM2903HDT





LOW POWER DUAL VOLTAGE COMPARATORS

- WIDE SINGLE SUPPLY VOLTAGE RANGE OR DUAL SUPPLIES +2V TO +36V OR $\pm 1V$ TO $\pm 18V$
- VERY LOW SUPPLY CURRENT (0.4mA) INDEPENDENT OF SUPPLY VOLTAGE (1mW/comparator at +5V)
- LOW INPUT BIAS CURRENT: 25nA TYP
- LOW INPUT OFFSET CURRENT: $\pm 5nA$ TYP
- INPUT COMMON-MODE VOLTAGE RANGE INCLUDES GROUND
- LOW OUTPUT SATURATION VOLTAGE: 250mV TYP. ($I_O = 4mA$)
- DIFFERENTIAL INPUT VOLTAGE RANGE EQUAL TO THE SUPPLY VOLTAGE
- TTL, DTL, ECL, MOS, CMOS COMPATIBLE OUTPUTS

DESCRIPTION

This device consists of two independent low power voltage comparators designed specifically to operate from a single supply over a wide range of voltages. Operation from split power supplies is also possible.

These comparators also have a unique characteristic in that the input common-mode voltage range includes ground even though operated from a single power supply voltage.

ORDER CODE

Part Number	Temperature Range	Package	
		Wafer	SO8
JLM2903H- E6D1	-40°C, +150°C	•	
LM2903HD	-40°C, +150°C		•

D = Small Outline Package (SO) - also available in Tape & Reel (DT)

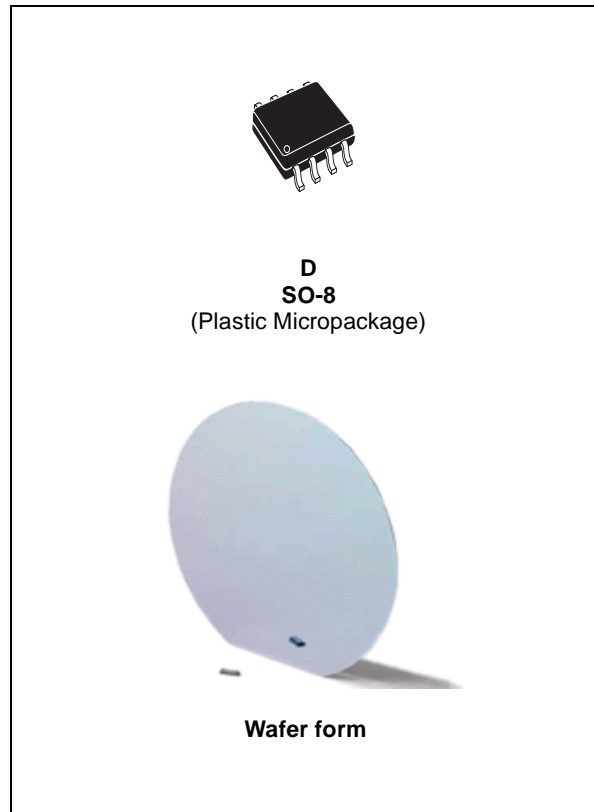

PIN CONNECTIONS (top view)

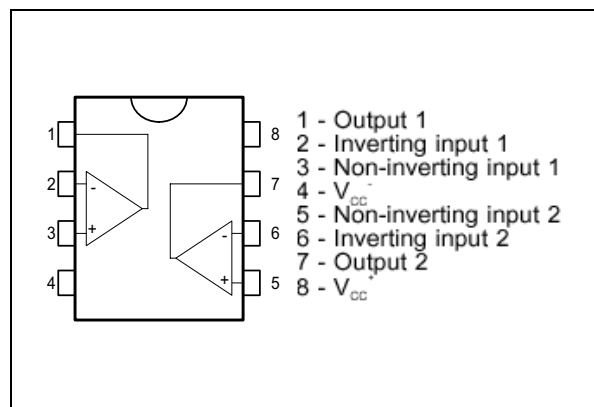

SCHEMATIC DIAGRAM (1/2 LM2903)

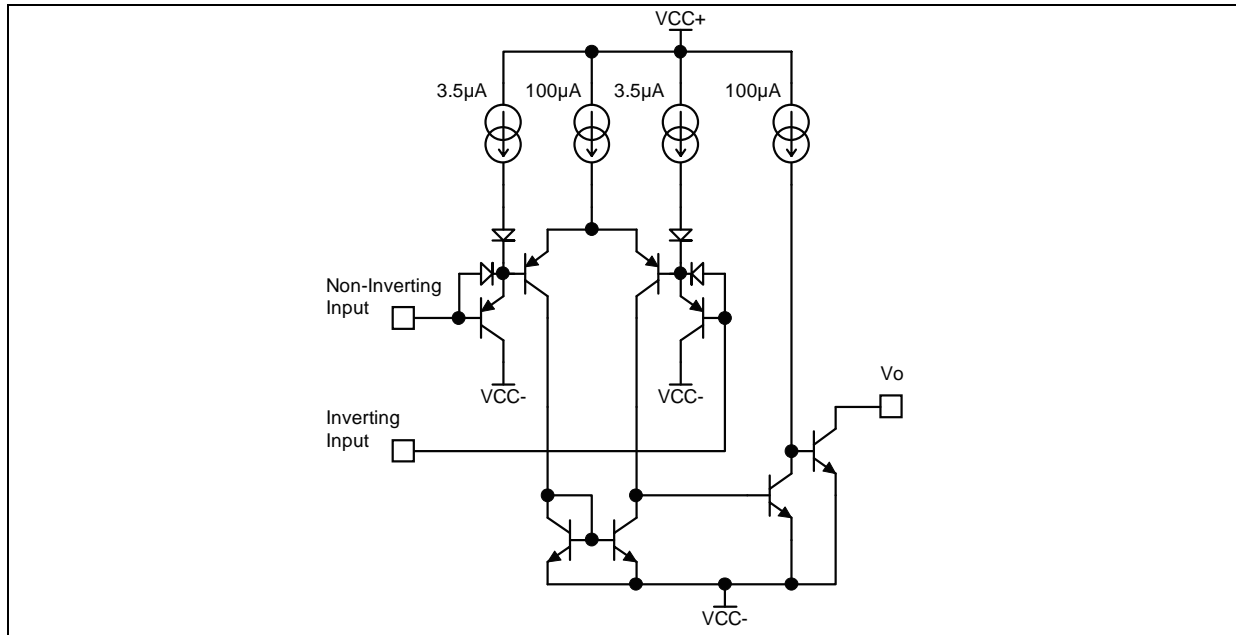

PAD LOCATIONS

Name	Pad placement		Pad dimensions	
	X	Y	X	Y
GND	830	415	90	90
E+1	750	100	90	90
E-1	400	100	90	90
OUT1	100	100	90	90
Vcc +	65	415	90	90
OUT2	90	730	90	90
E-2	410	720	90	90
E+2	760	720	90	90

All dimensions are specified in micrometer (um).

ABSOLUTE MAXIMUM RATINGS

Symbol	Parameter	Value	Unit
V_{CC}	Supply Voltage	± 18 or 36	V
V_{ID}	Differential Input Voltage	± 36	V
V_I	Input Voltage	-0.3 to +36	V
	Output Short-circuit to Ground ¹⁾	20	mA
P_d	Power Dissipation at $T_{AMB} = +25^\circ C$ ²⁾	710	mW
T_{stg}	Storage Temperature Range	-65 to +150	$^\circ C$

- Short-circuit from the output to V_{CC}^+ can cause excessive heating and eventual destruction. The maximum output current is approximately 20mA, independent of the magnitude of V_{CC}^+ .
- P_d is calculated with $T_{amb} = +25^\circ C$, $T_{Junction} = +150^\circ C$ and $R_{thja} = 175^\circ C/W$ for SO8 package

OPERATING CONDITIONS

Symbol	Parameter	Value	Unit
V_{CC}^+	Supply Voltage	2 to 36	V
T_{oper}	Operating Free-Air Temperature Range	-40 to +150	°C

ELECTRICAL CHARACTERISTICS

 $V_{CC}^+ = 5V$, $V_{CC}^- = GND$, $T_{amb} = 25^\circ C$ (unless otherwise specified)

Symbol	Parameter	Min.	Typ.	Max.	Unit
V_{IO}	Input Offset Voltage ¹⁾ $T_{amb} = +25^\circ C$ $T_{min} \leq T_{amb} \leq T_{max}$.		1	7 15	mV
I_{IO}	Input Offset Current $T_{amb} = +25^\circ C$ $T_{min} \leq T_{amb} \leq T_{max}$.		5	50 150	nA
I_{IB}	Input Bias Current ²⁾ $T_{amb} = +25^\circ C$ $T_{min} \leq T_{amb} \leq T_{max}$.		25	250 400	nA
A_{VD}	Large Signal Voltage Gain ($V_{CC} = 15V, R_L = 15k\Omega, V_o = 1$ to $11V$)	25	200		V/mV
I_{CC}	Supply Current (all comparators) $V_{CC} = 5V$, no load $V_{CC} = 30V$, no load		0.4 1	1 2.5	mA
V_{ICM}	Input Common Mode Voltage Range ($V_{CC} = 30V$) ³⁾ $T_{amb} = +25^\circ C$ $T_{min} \leq T_{amb} \leq T_{max}$.	0 0		$V_{CC}^+ - 1.5$ $V_{CC}^+ - 2$	V
V_{ID}	Differential Input Voltage ⁴⁾			V_{CC}^+	V
V_{OL}	Low Level Output Voltage ($V_{id} = -1V, I_{sink} = 4mA$) $T_{amb} = +25^\circ C$ $T_{min} \leq T_{amb} \leq T_{max}$		250	400 800	mV
I_{OH}	High Level Output Current ($V_{CC} = V_o = 30V, V_{id} = 1V$) $T_{amb} = +25^\circ C$ $T_{min} \leq T_{amb} \leq T_{max}$		0.1	1	nA μA
I_{SINK}	Output Sink Current ($V_{id} = -1V, V_o = 1.5V$) $T_{amb} = +25^\circ C$ $T_{min} \leq T_{amb} \leq T_{max}$	6 2	16		mA
t_{RE}	Small Signal Response Time ⁵⁾ ($R_L = 5.1k\Omega$ to V_{CC}^+)		1.3		μs
t_{REL}	Large Signal Response Time ⁶⁾ TTL Input ($V_{ref} = +1.4V, R_L = 5.1k\Omega$ to V_{CC}^+) Output Signal at 50% of final value Output Signal at 95% of final value			500 1	ns μs

- At output switch point, $V_O = 1.4V$, $R_S = 0\Omega$ with V_{CC}^+ from 5V to 30V, and over the full input common-mode range (0V to $V_{CC}^+ - 1.5V$).
- The direction of the input current is out of the IC due to the PNP input stage. This current is essentially constant, independent of the state of the output, so no loading charge exists on the reference of input lines
- The input common-mode voltage of either input signal voltage should not be allowed to go negative by more than 0.3V. The upper end of the common-mode voltage range is $V_{CC}^+ - 1.5V$, but either or both inputs can go to +30V without damage.
- Positive excursions of input voltage may exceed the power supply level. As long as the other voltage remains within the common-mode range, the comparator will provide a proper output state.
The low input voltage state must not be less than $-0.3V$ (or 0.3V below the negative power supply, if used)
- The response time specified is for a 100mV input step with 5mV overdrive.
- Maximum values are guaranteed by design & evaluation.

SUPPLY CURRENT versus SUPPLY VOLTAGE

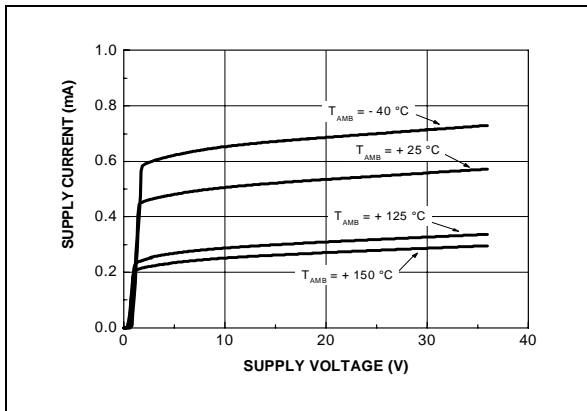

RESPONSE TIME FOR VARIOUS INPUT OVERDRIVES - NEGATIVE TRANSITION

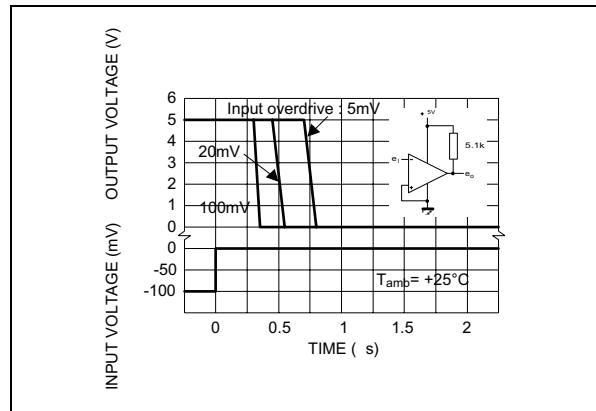

INPUT CURRENT versus SUPPLY VOLTAGE

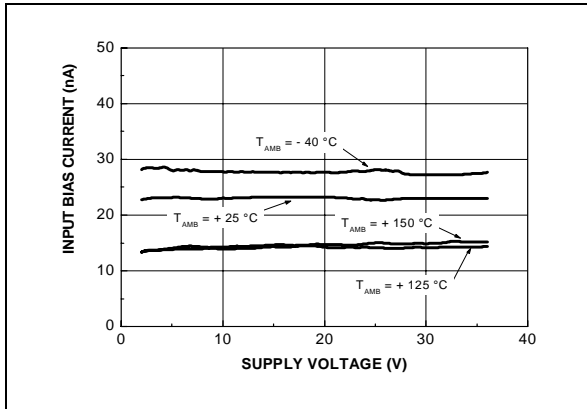

RESPONSE TIME FOR VARIOUS INPUT OVERDRIVES - POSITIVE TRANSITION

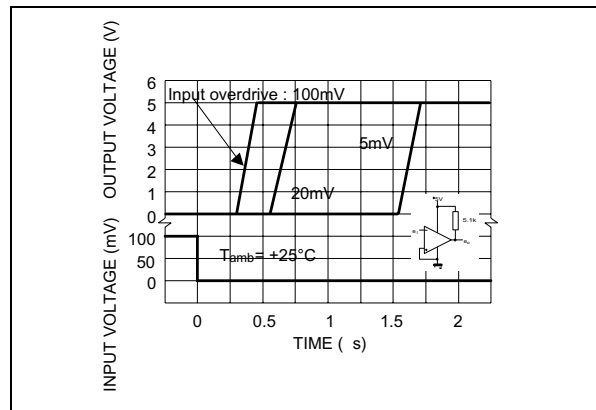

OUTPUT SATURATION VOLTAGE versus OUTPUT CURRENT ($V_{CC}=5V$)

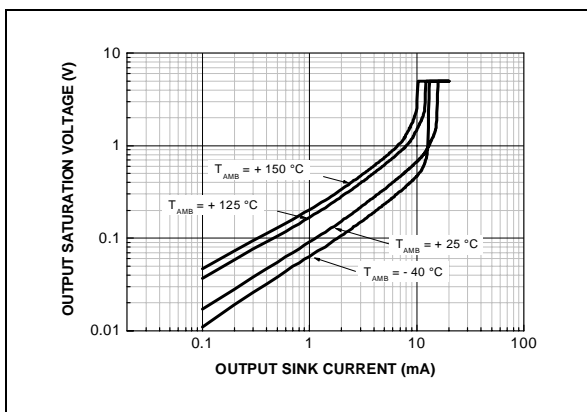

PACKAGE MECHANICAL DATA

SO-8 MECHANICAL DATA						
DIM.	mm.			inch		
	MIN.	TYP.	MAX.	MIN.	TYP.	MAX.
A	1.35		1.75	0.053		0.069
A1	0.10		0.25	0.04		0.010
A2	1.10		1.65	0.043		0.065
B	0.33		0.51	0.013		0.020
C	0.19		0.25	0.007		0.010
D	4.80		5.00	0.189		0.197
E	3.80		4.00	0.150		0.157
e		1.27			0.050	
H	5.80		6.20	0.228		0.244
h	0.25		0.50	0.010		0.020
L	0.40		1.27	0.016		0.050
k	8° (max.)					
ddd			0.1			0.04

0016023/C

Information furnished is believed to be accurate and reliable. However, STMicroelectronics assumes no responsibility for the consequences of use of such information nor for any infringement of patents or other rights of third parties which may result from its use. No license is granted by implication or otherwise under any patent or patent rights of STMicroelectronics. Specifications mentioned in this publication are subject to change without notice. This publication supersedes and replaces all information previously supplied. STMicroelectronics products are not authorized for use as critical components in life support devices or systems without express written approval of STMicroelectronics.

The ST logo is a registered trademark of STMicroelectronics
All other names are the property of their respective owners.

© 2003 STMicroelectronics - All Rights Reserved

STMicroelectronics GROUP OF COMPANIES



Australia - Belgium - Brazil - Canada - China - Czech Republic - Finland - France - Germany
Hong Kong - India - Israel - Italy - Japan - Malaysia - Malta - Morocco - Singapore - Spain
Sweden - Switzerland - United Kingdom - United States

<http://www.st.com>



Looking for pricing, stock, or lifecycle information?

Click below to explore more details on WIN SOURCE:

-  [View LM2903HDT](#) on WIN SOURCE
-  [STMicroelectronics](#) Information

Optimize Your Supply Chain with WIN SOURCE Solutions

-  Global Sourcing Solution
-  Obsolete Management
-  Cost Control Management
-  Shortage Management
-  Alternative Solution
-  Excess Inventory Management