



**THE DATASHEET OF  
AD581LH**



### FEATURES

- Laser trimmed to high accuracy**  
10.000 V  $\pm$ 5 mV (L and U models)
- Trimmed temperature coefficient**  
5 ppm/ $^{\circ}$ C maximum, 0 $^{\circ}$ C to 70 $^{\circ}$ C (L model)  
10 ppm/ $^{\circ}$ C maximum, -55 $^{\circ}$ C to +125 $^{\circ}$ C (U model)
- Excellent long-term stability**  
25 ppm/1000 hrs (noncumulative)
- 10 V reference capability**
- Low quiescent current: 1.0 mA maximum**
- 10 mA current output capability**
- 3-pin TO-5 package**
- MIL-STD-883 compliant versions available**

### GENERAL DESCRIPTION

The AD581 is a 3-pin, temperature compensated, monolithic, band gap voltage reference that provides a precise 10.00 V output from an unregulated input level ranging from 12 V to 30 V. Laser wafer trimming (LWT) is used to trim both the initial error at +25 $^{\circ}$ C as well as the temperature coefficient, resulting in high precision performance previously available only in expensive hybrids or oven regulated modules. The 5 mV initial error tolerance and 5 ppm/ $^{\circ}$ C guaranteed temperature coefficient of the AD581L is available in a monolithic voltage reference.

The band gap circuit design used in the AD581 offers several advantages over classical Zener breakdown diode techniques. Most important, no external components are required to achieve full accuracy and significant stability to low power systems. In addition, total supply current to the device, including the output buffer amplifier (which can supply up to 10 mA) is typically 750  $\mu$ A. The long-term stability of the band gap design is equivalent to selected Zener reference diodes.

The AD581 is recommended for use as a reference for 8-, 10- or 12-bit digital-to-analog converters (DACs) that require an external precision reference. The device is also ideal for all types of analog-to-digital converters (ADCs) up to 14-bit accuracy, either successive approximation or integrating designs, and can generally offer better performance than that provided by standard self-contained references.

### FUNCTIONAL BLOCK DIAGRAM

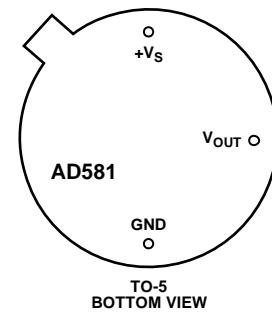

Figure 1.

08014-001

The AD581J, AD581K, and AD581L are specified for operation from 0 $^{\circ}$ C to 70 $^{\circ}$ C; the AD581S, AD581T, and AD581U are specified for the -55 $^{\circ}$ C to +125 $^{\circ}$ C range. All grades are packaged in a hermetically sealed 3-pin TO-5 metal can.

### PRODUCT HIGHLIGHTS

1. Laser trimming of both initial accuracy and temperature coefficient results in very low errors over temperature without the use of external components. The AD581L has a maximum deviation from 10.000 V of  $\pm$ 7.25 mV from 0 $^{\circ}$ C to 70 $^{\circ}$ C, whereas the AD581U guarantees  $\pm$ 15 mV maximum total error without external trims from -55 $^{\circ}$ C to +125 $^{\circ}$ C.
2. Because the laser trimming is done on the wafer prior to separation into individual chips, the AD581 is extremely valuable to hybrid designers for its ease of use, lack of required external trims, and inherent high performance.
3. The AD581 can also be operated in a 2-pin Zener mode to provide a precision -10 V reference with just one external resistor to the unregulated supply. The performance in this mode is nearly equal to that of the standard 3-pin configuration.
4. Advanced circuit design using the band gap concept allows the AD581 to give full performance with an unregulated input voltage down to 13 V. With an external resistor, the device operates with a supply as low as 11.4 V.
5. The AD581 is available in versions compliant with MILSTD-883. Refer to the military datasheet for detailed specifications.

#### Rev. C

Information furnished by Analog Devices is believed to be accurate and reliable. However, no responsibility is assumed by Analog Devices for its use, nor for any infringements of patents or other rights of third parties that may result from its use. Specifications subject to change without notice. No license is granted by implication or otherwise under any patent or patent rights of Analog Devices. Trademarks and registered trademarks are the property of their respective owners.

**TABLE OF CONTENTS**

Features .....	1	Output Current Characteristics.....	7
Functional Block Diagram .....	1	Dynamic Performance.....	7
General Description .....	1	Precision High Current Supply .....	8
Product Highlights .....	1	Connection for Reduced Primary Supply.....	8
Revision History .....	2	The AD581 as a Current Limiter .....	9
Specifications.....	3	Negative 10 V Reference.....	9
Absolute Maximum Ratings.....	5	10 V Reference with Multiplying CMOS DACs or ADCs .....	9
ESD Caution.....	5	Precision 12-Bit DAC Reference .....	9
Applying the AD581.....	6	Outline Dimensions .....	11
Voltage Variation vs. Temperature .....	6	Ordering Guide .....	11

**REVISION HISTORY****4/09—Rev. B to Rev. C**

Updated Format.....	Universal
Changes to Table 1.....	3
Changes to Figure 2.....	6
Changes to Figure 11 .....	8
Changes to 10 V Reference with Multiplying CMOS DACs or ADCs Section .....	9
Changes to Precision 12-Bit DAC Reference Section.....	9
Changes to Figure 13.....	9
Changes to Figure 15 and Figure 16.....	10
Updated Outline Dimensions .....	11
Changes to Ordering Guide .....	11

## SPECIFICATIONS

@  $V_{IN} = +15\text{ V}$  and  $T_A = +25^\circ\text{C}$ .

Specifications shown in **boldface** are tested on all production units at final electrical test. Results from those tests are used to calculate outgoing quality levels. All minimum and maximum specifications are guaranteed, although only those shown in **boldface** are tested on all production units.

**Table 1.**

Model	AD581J			AD581K			AD581L			Units
	Min	Typ	Max	Min	Typ	Max	Min	Typ	Max	
OUTPUT VOLTAGE TOLERANCE (Error from Nominal 10,000 V Output)			<b>±30</b>			<b>±10</b>			<b>±5</b>	mV
OUTPUT VOLTAGE CHANGE Maximum Deviation from +25°C Value, $T_{MIN}$ to $T_{MAX}$			<b>±13.5</b>			<b>±6.75</b>			<b>±2.25</b>	mV
Temperature Coefficient			30			15			5	ppm/°C
LINE REGULATION $15\text{ V} \leq V_{IN} \leq 30\text{ V}$			<b>3.0</b> (0.002)			<b>3.0</b> (0.002)			<b>3.0</b> (0.002)	mV %/V
$13\text{ V} \leq V_{IN} \leq 15\text{ V}$			<b>1.0</b> (0.005)			<b>1.0</b> (0.005)			<b>1.0</b> (0.005)	mV %/V
LOAD REGULATION $0 \leq I_{OUT} \leq 5\text{ mA}$		200	<b>500</b>		200	<b>500</b>		200	<b>500</b>	μV/mA
QUIESCENT CURRENT		0.75	<b>1.0</b>		0.75	<b>1.0</b>		0.75	<b>1.0</b>	mA
TURN-ON SETTLING TIME TO 0.1% <sup>1</sup>		200			200			200		μs
NOISE (0.1 Hz TO 10 Hz)		40			40			40		μV (p-p)
LONG-TERM STABILITY		25			25			25		ppm/1000 hr
SHORT-CIRCUIT CURRENT		30			30			30		mA
OUTPUT CURRENT Source @ +25°C			10			10			10	mA
Source $T_{MIN}$ to $T_{MAX}$			5			5			5	mA
Sink $T_{MIN}$ to $T_{MAX}$			5			5			5	μA
TEMPERATURE RANGE Specified	0		70	0		70	0		70	°C
Operating	-65		+150	-65		+150	-65		+150	°C
PACKAGE OPTION <sup>2</sup> TO-5 (H-03B)		AD581JH			AD581KH			AD581LH		

<sup>1</sup> See Figure 7.

<sup>2</sup> H indicates the hermetic metal can.

# AD581

Table 2.

Model	AD581S			AD581T			AD581U			Units
	Min	Typ	Max	Min	Typ	Max	Min	Typ	Max	
OUTPUT VOLTAGE TOLERANCE (Error from Nominal 10,000 V Output)			<b>±30</b>			<b>±10</b>			<b>±5</b>	mV
OUTPUT VOLTAGE CHANGE Maximum Deviation from +25°C Value, T <sub>MIN</sub> to T <sub>MAX</sub> Temperature Coefficient			<b>±30</b>			<b>±15</b>			<b>±10</b>	mV  ppm/°C
LINE REGULATION 15 V ≤ V <sub>IN</sub> ≤ 30 V  13 V ≤ V <sub>IN</sub> ≤ 15 V			<b>3.0</b> (0.002)			<b>3.0</b> (0.002)			<b>3.0</b> (0.002)	mV %/V mV %/V
LOAD REGULATION 0 ≤ I <sub>OUT</sub> ≤ 5 mA		200	<b>500</b>		200	<b>500</b>		200	<b>500</b>	μV/mA
QUIESCENT CURRENT		0.75	<b>1.0</b>		0.75	<b>1.0</b>		0.75	<b>1.0</b>	mA
TURN-ON SETTLING TIME TO 0.1% <sup>1</sup>		200			200			200		μs
NOISE (0.1 Hz TO 10 Hz)		40			40			40		μV (p-p)
LONG-TERM STABILITY		25			25			25		ppm/1000 hr
SHORT-CIRCUIT CURRENT		30			30			30		mA
OUTPUT CURRENT Source @ +25°C Source T <sub>MIN</sub> to T <sub>MAX</sub> Sink T <sub>MIN</sub> to T <sub>MAX</sub> Sink -55°C to +85°C			10 5 200 5			10 5 200 5			10 5 200 5	mA mA μA mA
TEMPERATURE RANGE Specified Operating		-55 -65	+125 +150		-55 -65	+125 +150		-55 -65	+125 +150	°C °C
PACKAGE OPTION <sup>2</sup> TO-5 (H-03B)		AD581SH			AD581TH			AD581UH		

<sup>1</sup> See Figure 7.

<sup>2</sup> H indicates hermetic metal can.

## ABSOLUTE MAXIMUM RATINGS

Table 3.

Parameter	Rating
Input Voltage	40 V
Power Dissipation @ +25°C	600 mW
Operating Junction Temperature Range	-55°C to +150°C
Lead Temperature (Soldering 10 sec)	+300°C
Thermal Resistance Junction-to-Ambient	150°C/W

Stresses above those listed under Absolute Maximum Ratings may cause permanent damage to the device. This is a stress rating only; functional operation of the device at these or any other conditions above those indicated in the operational section of this specification is not implied. Exposure to absolute maximum rating conditions for extended periods may affect device reliability.

### ESD CAUTION



**ESD (electrostatic discharge) sensitive device.** Charged devices and circuit boards can discharge without detection. Although this product features patented or proprietary protection circuitry, damage may occur on devices subjected to high energy ESD. Therefore, proper ESD precautions should be taken to avoid performance degradation or loss of functionality.

## APPLYING THE AD581

The AD581 is easy to use in virtually all precision reference applications. The three pins are simply: primary supply, ground, and output, with the case grounded. No external components are required even for high precision applications; the degree of desired absolute accuracy is achieved simply by selecting the required device grade. The AD581 requires less than 1 mA quiescent current from an operating supply range of 13 V to 30 V.

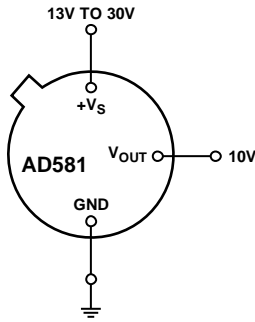

Figure 2. Pin Configuration (Bottom View)

An external fine trim may be desired to set the output level to exactly 10.000 V within less than a millivolt (calibrated to a main system reference). System calibration may also require a reference slightly different from 10.00 V. In either case, the optional trim circuit shown in Figure 3 can offset the output by up to  $\pm 30$  mV (with the 22  $\Omega$  resistor), if needed, with minimal effect on other device characteristics.

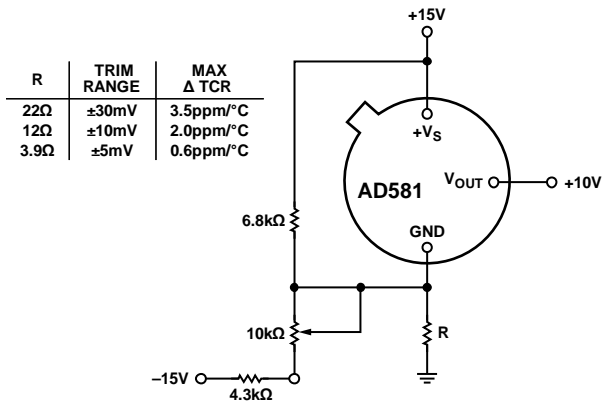

Figure 3. Optional Fine Trim Configuration

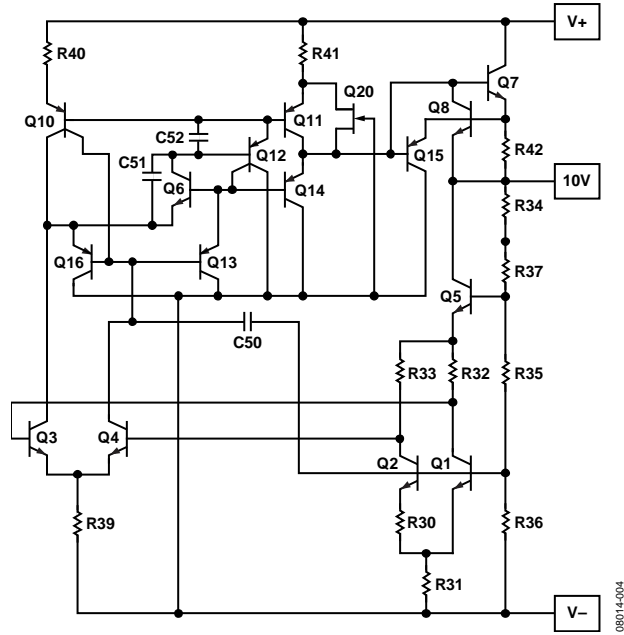

Figure 4. Simplified Schematic

### VOLTAGE VARIATION vs. TEMPERATURE

Some confusion exists in the area of defining and specifying reference voltage error over temperature. Historically, references have been characterized using a maximum deviation per degree Celsius; that is, 10 ppm/ $^{\circ}$ C. However, because of nonlinearities in temperature characteristics, which originated in standard Zener references (such as S-type characteristics) manufacturers opt for the maximum limit error band approach to specify devices. This technique involves measurement of the output at three, five, or more different temperatures to guarantee that the output voltage falls within the given error band. The temperature characteristic of the AD581 consistently follows the S-curve shown in Figure 5. Three-point measurement of each device guarantees the error band over the specified temperature range.

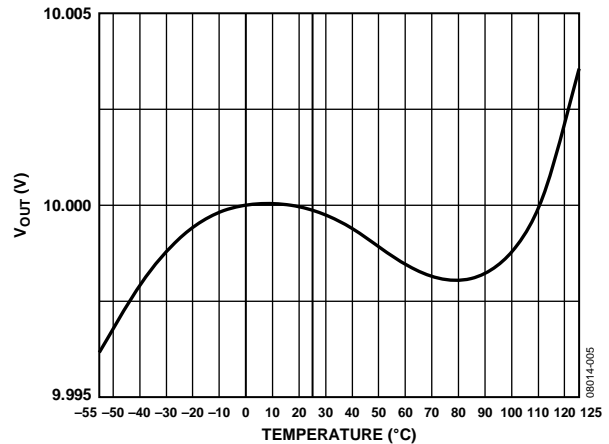

Figure 5. Typical Temperature Characteristic

The error band which is guaranteed with the AD581 is the maximum deviation from the initial value at +25°C; this error band is of more use to a designer than one which simply guarantees the maximum total change over the entire range (that is, in the latter definition, all of the changes could occur in the positive direction). Thus, with a given grade of the AD581, the designer can easily determine the maximum total error from initial tolerance plus temperature variation (for example, for the AD581T, the initial tolerance is ±10 mV, the temperature error band is ±15 mV, thus the unit is guaranteed to be 10.000 V ±25 mV from -55°C to +125°C).

**OUTPUT CURRENT CHARACTERISTICS**

The AD581 has the capability to either source or sink current and provide good load regulation in either direction, although it has better characteristics in the source mode (positive current into the load). The circuit is protected for shorts to either positive supply or ground. The output voltage vs. output current characteristics of the device are shown in Figure 6. Source current is displayed as negative current in the figure; sink current is positive. Note that the short-circuit current (that is, 0 V output) is about 28 mA; when shorted to +15 V, the sink current goes to about 20 mA.

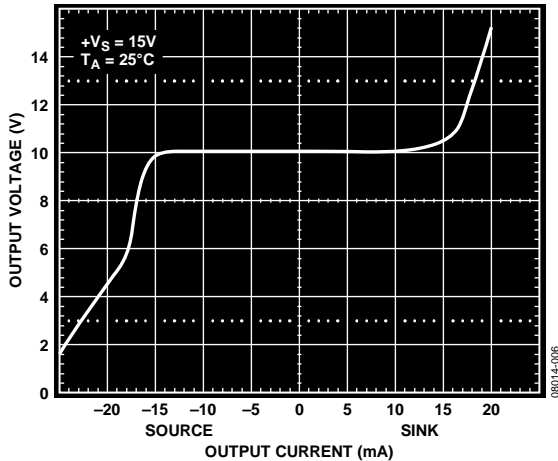

Figure 6. Output Voltage vs. Sink and Source Current

**DYNAMIC PERFORMANCE**

Many low power instrument manufacturers have been increasingly concerned with the turn-on characteristics of the components used in their systems. Fast turn-on components often enable the end user to keep power off when not needed, and yet respond quickly when the power is turned on for operation. Figure 7 displays the turn-on characteristic of the AD581. This characteristic is generated from a cold start operation and represents the true turn-on waveform after an extended period with the supplies off. The figure shows both the coarse and fine transient characteristics of the device; the total settling time to within ±10 mV is about 180 μs, and there is no long thermal tail appearing after the point.

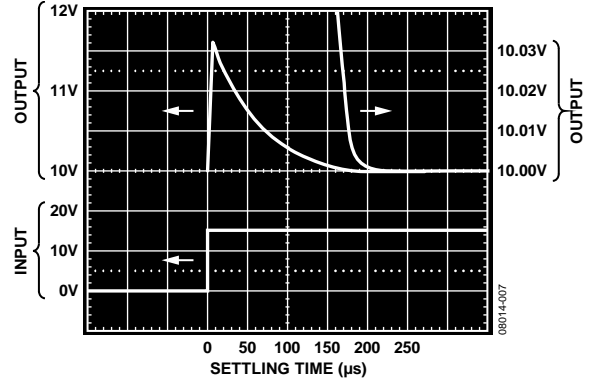

Figure 7. Output Settling Characteristic

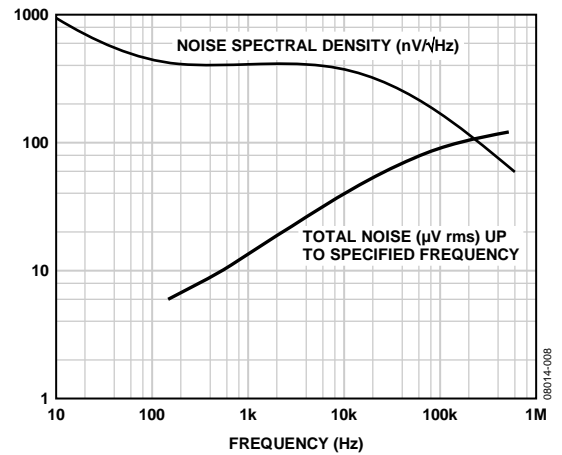

Figure 8. Spectral Noise Density and Total rms Noise vs. Frequency

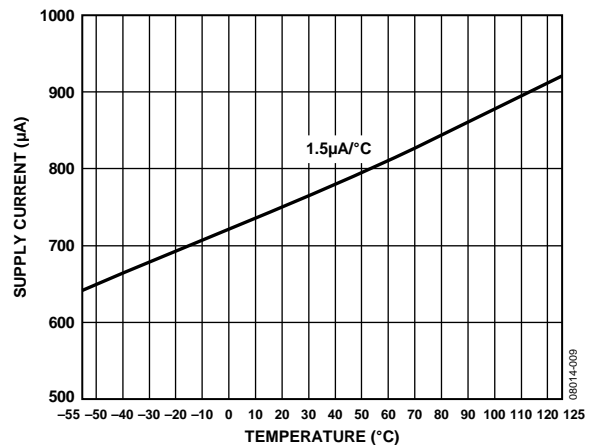

Figure 9. Quiescent Current vs. Temperature

# AD581

## PRECISION HIGH CURRENT SUPPLY

The AD581 can be easily connected with power pnp or power Darlington pnp devices to provide much greater output current capability. The circuit shown in Figure 10 delivers a precision 10 V output with up to 4 A supplied to the load. The 0.1  $\mu$ F capacitor is required only if the load has a significant capacitive component. If the load is purely resistive, improved high frequency supply rejection results from removing the capacitor.

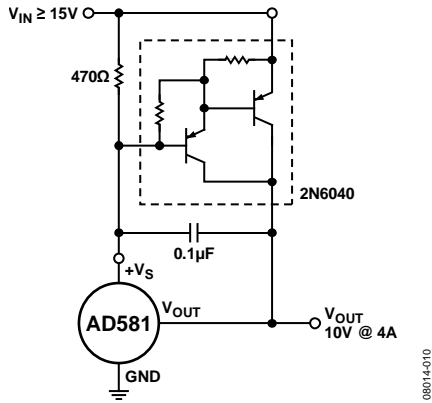

Figure 10. High Current Precision Supply

## CONNECTION FOR REDUCED PRIMARY SUPPLY

Whereas line regulation is specified down to 13 V, the typical AD581 works as specified  $\leq 12$  V. The current sink capability allows even lower supply voltage capability such as operation from  $12\text{ V} \pm 5\%$  as shown in Figure 11. The 560  $\Omega$  resistor reduces the current supplied by the AD581 to a manageable level at a full 5 mA load. Note that the other band gap references, without current sink capability, may be damaged by use in this circuit configuration.

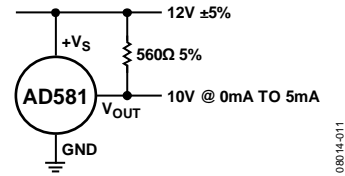
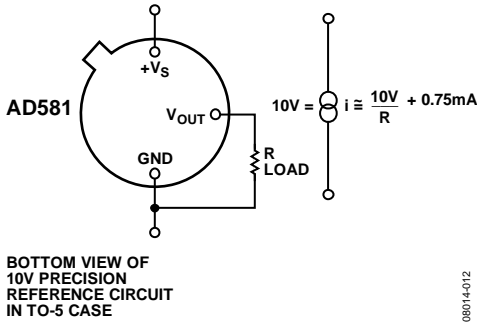

Figure 11. 12 V Supply Connection

## THE AD581 AS A CURRENT LIMITER

The AD581 represents an alternative to current limiter diodes that require factory selection to achieve a desired current. This approach often results in temperature coefficients of 1%/°C. The AD581 approach is not limited to a defined set current limit; it can be programmed from 0.75 mA to 5 mA with the insertion of a single external resistor. Of course, the minimum voltage required to drive the connection is 13 V. The AD580, which is a 2.5 V reference, can be used in this type of circuit with compliance voltage down to 4.5 V.



BOTTOM VIEW OF 10V PRECISION REFERENCE CIRCUIT IN TO-5 CASE

Figure 12. A Two-Component Precision Current Limiter

## NEGATIVE 10 V REFERENCE

The AD581 can also be used in a 2-pin Zener mode to provide a precision -10.00 V reference. As shown in Figure 13, the +Vs and VOUT pins are connected together to the high supply (in this case, ground). The ground pin is connected through a resistor to the negative supply. Thus, the output is taken from the ground pin instead of VOUT. With 1 mA flowing through the AD581 in this mode, a typical unit shows a 2 mV increase in output level over that produced in the 3-pin mode. Note also that the effective output impedance in this connection increases from 0.2 Ω typical to 2 Ω. It is essential to arrange the output load and the supply resistor, R<sub>s</sub>, so that the net current through the AD581 is always between 1 mA and 5 mA. For operation to +125°C, the net current should be between 2 mA and 5 mA. The temperature characteristics and long-term stability of the device are essentially the same as that of a unit used in the standard 3-pin mode.

The AD581 can also be used in a 2-pin mode to develop a positive reference. +Vs and VOUT are tied together and to the positive supply through an appropriate supply resistor. The performance characteristics are similar to those of the negative 2-pin connection. The only advantage of this connection over the standard 3-pin connection is that a lower primary supply can be used, as low as 10.5 V. This type of operation requires considerable attention to load and primary supply regulation to maintain the AD581 within its regulating range of 1 mA to 5 mA (2 mA to 5 mA for operation beyond +85°C).

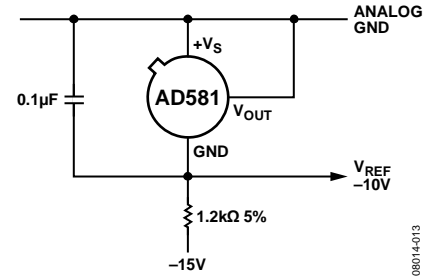

Figure 13. 2-Pin -10 V Reference

## 10 V REFERENCE WITH MULTIPLYING CMOS DACs OR ADCs

The AD581 is ideal for application with the entire AD7533 series of 10- and 12-bit multiplying CMOS DACs, especially for low power applications. It is equally suitable for the AD7574 8-bit ADC. In the standard hook-up, as shown in Figure 15, the +10 V reference is inverted by the amplifier/DAC configuration to produce a 0 V to -10 V range. If an OP1177 amplifier is used, total quiescent supply current is typically 2 mA. If a 0 V to +10 V full-scale range is desired, the AD581 can be connected to the CMOS DAC in its -10 V Zener mode, as shown in Figure 13 (the -10 V<sub>REF</sub> output is connected directly to the V<sub>REF IN</sub> of the CMOS DAC). The AD581 is normally used in the -10 V mode with the AD7574 to give a 0 V to +10 V ADC range. This is shown in Figure 15. Bipolar output applications and other operating details can be found in the data sheets for the CMOS products.

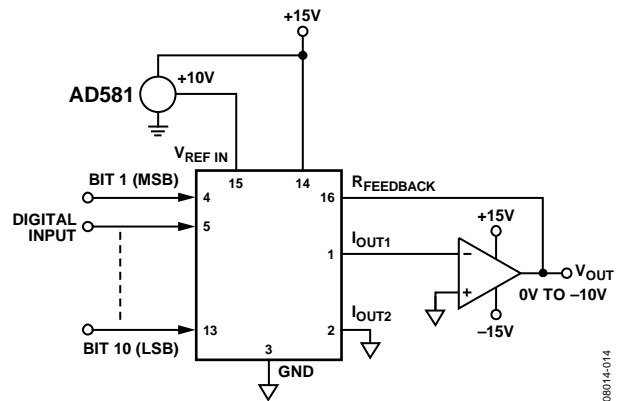

Figure 14. Low Power 10-Bit CMOS DAC Application

## PRECISION 12-BIT DAC REFERENCE

AD565A, like most DACs, is designed to operate with a +10 V reference element. In the AD565A, this 10 V reference voltage is converted into a reference current of approximately 0.5 mA via the internal 19.95 kΩ resistor (in series with the external 100 Ω trimmer). The gain temperature coefficient of the AD565A is primarily governed by the temperature tracking of the 19.95 kΩ resistor and the 5 kΩ to 10 kΩ span resistors; gain TC is guaranteed to 3 ppm/°C. Thus, using the AD581L (at 5 ppm/°C) as the

# AD581

10 V reference guarantees a maximum full-scale temperature coefficient of 8 ppm/°C over the commercial range. The 10 V reference also supplies the normal 1 mA bipolar offset current through the 9.95 kΩ bipolar offset resistor. Consequently, the bipolar offset TC depends only on TC matching of the bipolar offset resistor to the input reference resistor and is guaranteed to 3 ppm/°C.

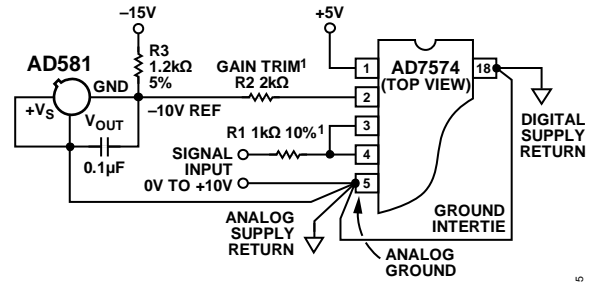

\*R1 AND R2 CAN BE OMITTED IF GAIN TRIM IS NOT REQUIRED.

Figure 15. AD581 as -10 V Reference for CMOS ADC

08014-015

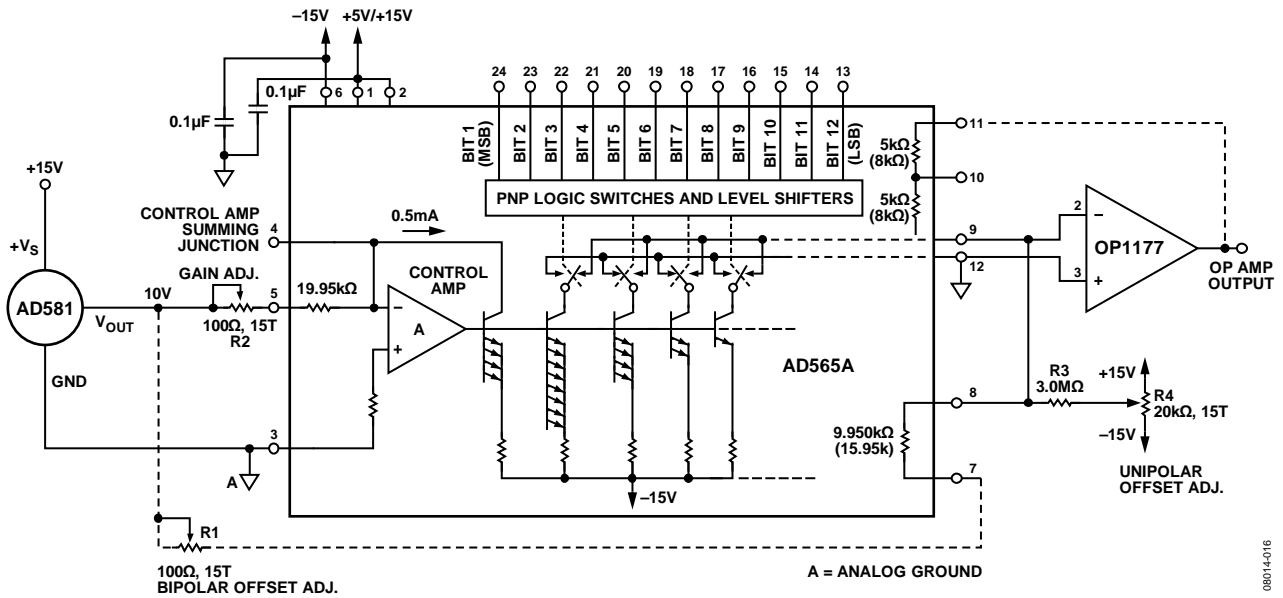
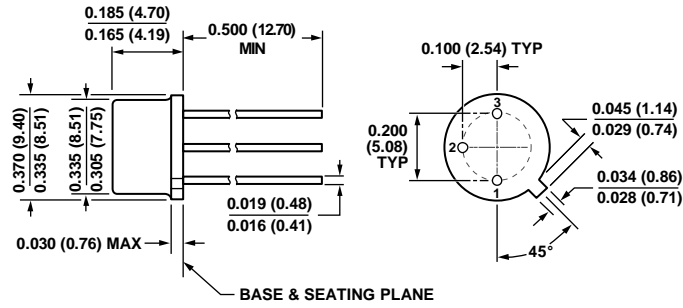

Figure 16. Precision 12-Bit DAC

08014-016

# OUTLINE DIMENSIONS



CONTROLLING DIMENSIONS ARE IN INCHES; MILLIMETER DIMENSIONS (IN PARENTHESES) ARE ROUNDED-OFF INCH EQUIVALENTS FOR REFERENCE ONLY AND ARE NOT APPROPRIATE FOR USE IN DESIGN.

030309-A

Figure 17. 3-Pin Metal Header Package [TO-5] (H-03B)

Dimensions shown in inches and (millimeters)

## ORDERING GUIDE

Model	Temperature Range	Package Description	Package Option
AD581JH <sup>1</sup>	0°C to +70°C	3-Pin Metal Header Package (TO-5)	H-03B
AD581KH <sup>1</sup>	0°C to +70°C	3-Pin Metal Header Package (TO-5)	H-03B
AD581LH <sup>1</sup>	0°C to +70°C	3-Pin Metal Header Package (TO-5)	H-03B
AD581SH <sup>1</sup>	-55°C to +125°C	3-Pin Metal Header Package (TO-5)	H-03B
AD581TH <sup>1</sup>	-55°C to +125°C	3-Pin Metal Header Package (TO-5)	H-03B
AD581UH <sup>1</sup>	-55°C to +125°C	3-Pin Metal Header Package (TO-5)	H-03B



<sup>1</sup> RoHS compliant model as of Date Code 0713.

**AD581**

**NOTES**

## Looking for pricing, stock, or lifecycle information?

Click below to explore more details on WIN SOURCE:

-  [View AD581LH on WIN SOURCE](#)
-  [Analog Devices Inc. Information](#)

## Optimize Your Supply Chain with WIN SOURCE Solutions

-  Global Sourcing Solution
-  Obsolete Management
-  Cost Control Management
-  Shortage Management
-  Alternative Solution
-  Excess Inventory Management