



THE DATASHEET OF UCC2570DTR



Not Recommended for New Design

Low Power Pulse Width Modulator

FEATURES

- Low Power BiCMOS Process
- 85 μ A Start-up Current
- 1mA Run Current
- 1A Peak Gate Drive Output
- Voltage Feed Forward
- Programmable Duty Cycle Clamp
- Optocoupler Interface
- 500kHz Operation
- Soft Start
- Fault Counting Shutdown
- Fault Latch Off or Automatic Restart

DESCRIPTION

The UCC1570 family of pulse width modulators is intended for application in isolated switching supplies using primary side control and a voltage mode feedback loop. Made with a BiCMOS process, these devices feature low startup current for efficient off-line starting with a bootstrapped low voltage supply. Operating current is also very low; yet these devices maintain the ability to drive a power MOSFET gate at frequencies above 500kHz.

Voltage feedforward provides fast and accurate response to wide line voltage variation without the noise sensitivity of current mode control. Fast current limiting is included with the ability to latch off after a programmable number of repetitive faults has occurred. This allows the power supply to ride through a temporary overload, while still shutting down in the event of a permanent fault. Additional versatility is provided with a maximum duty cycle clamp programmable within a 20% to 80% range and line voltage sensing with a programmable window of allowable operation.

BLOCK DIAGRAM

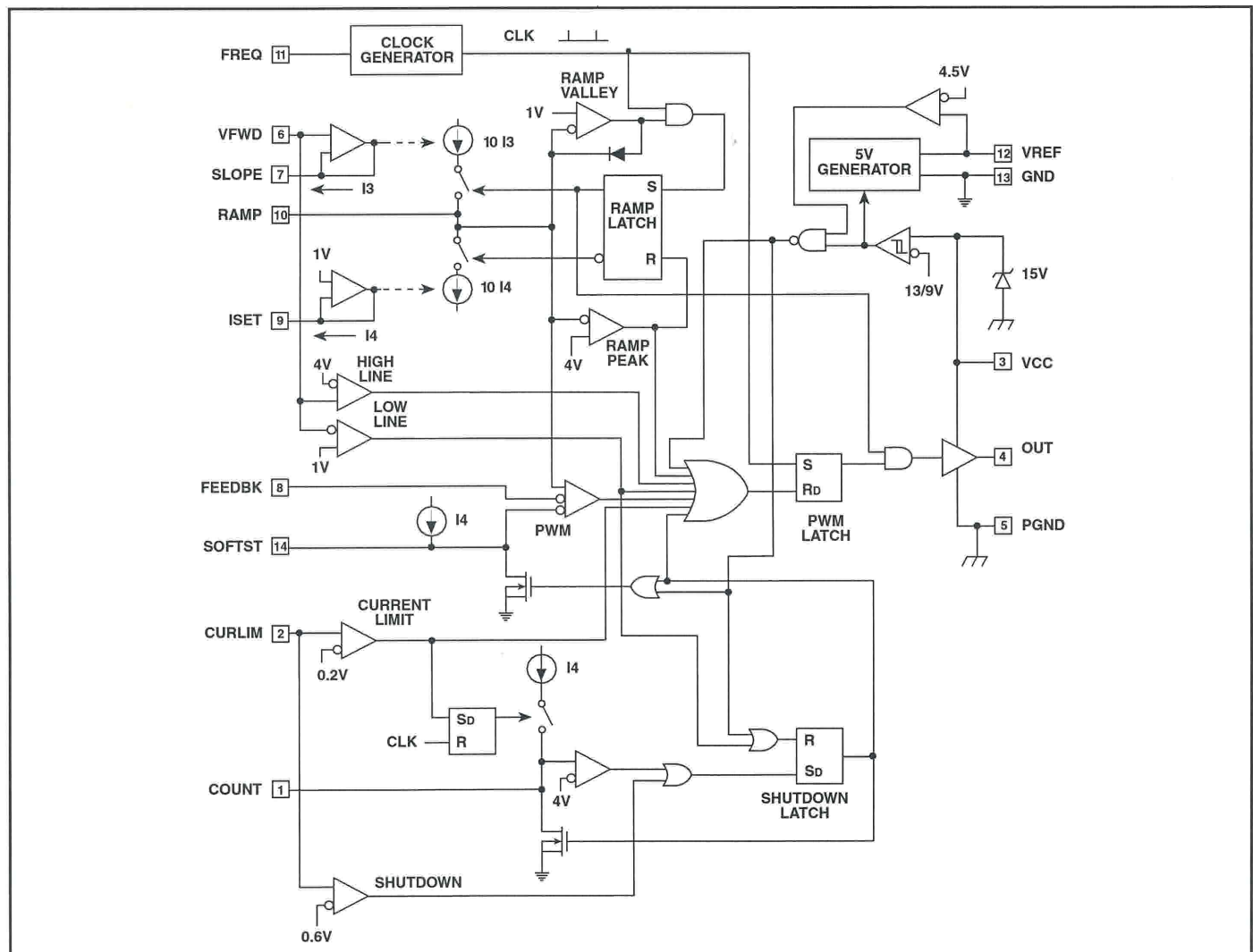

ABSOLUTE MAXIMUM RATINGS

Supply Voltage
(Limit Supply Current to 20mA) Self Limiting at 15V
Supply Current +20mA
Analog Inputs (CURLIM, VFWD, FEEDBK) 6V
Programming Current I_{SLOPE} , I_{SET} -1mA
Output Current I_{OUT}
DC ± 180 mA
Pulse (0.5ms) ± 1.2 A

Note: All voltages are with respect to GND. Currents are positive into the specified terminal. Consult Packaging Section of Databook for thermal limitations and considerations of package.

ORDERING INFORMATION

	Temperature Range	Package
UCC1570J	-55°C to +125°C	Ceramic Dip
UCC2570D	-40°C to +85°C	SOIC
UCC2750N		Plastic Dip
UCC3570D	0°C to +70°C	SOIC
UCC3570N		Plastic Dip

CONNECTION DIAGRAMS

DIL-14 (TOP VIEW)
N or J Package

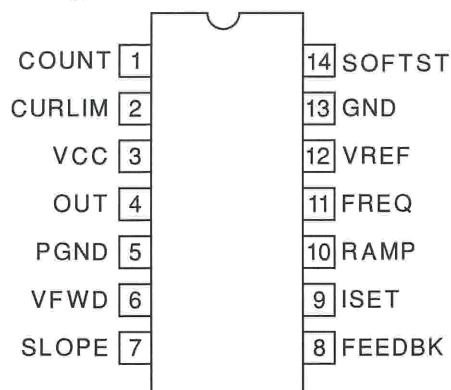

SOIC-14 (TOP VIEW)
D Package

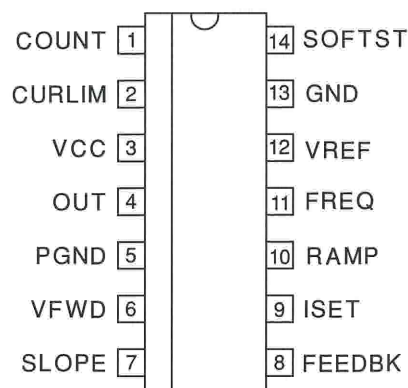

ELECTRICAL CHARACTERISTICS: Unless otherwise stated, these specifications apply for $T_A = 0$ to 70°C for the UCC3570, $T_A = -40$ to 85°C for the UCC2570, $T_A = -55$ to 125°C for the UCC1570, $R_{ISET} = 100\text{k}$, $R_{SLOPE} = 121\text{k}$, $C_{FREQ} = 180\text{pF}$, $C_{RAMP} = 150\text{pF}$, $V_{CC} = 11\text{V}$ and $T_A = T_J$.

PARAMETER	TEST CONDITIONS	Min	Typ	Max	Units
Reference					
VREF	$V_{CC} = 10$ to 13V , $I_{VREF} = 0$ to 2mA	4.9	5	5.1	V
Line Regulation	$V_{CC} = 10$ to 13V		2	10	mV
Load Regulation	$I_{VREF} = 0$ to 2mA		2	10	mV
Short Circuit Current	$V_{REF} = 0$		10	50	mA
VCC					
V_{th} (On)		12	13		V
V_{th} (Off)		8	9	10	V
Hysteresis		3	4	5	V
VCC	$I_{VCC} = 10\text{mA}$	13.5	15	16	V
I_{VCC} Start	$V_{CC} = 11\text{V}$, VCC Comparator Off		85	150	μA
I_{VCC} Run	VCC Comparator On		1	1.5	mA

ELECTRICAL CHARACTERISTICS: Unless otherwise stated, these specifications apply for $T_A = 0$ to 70°C for the UCC3570, $T_A = -40$ to 85°C for the UCC2570, $T_A = -55$ to 125°C for the UCC1570, $R_{\text{ISET}} = 100\text{k}$, $R_{\text{SLOPE}} = 121\text{k}$, $C_{\text{FREQ}} = 180\text{pF}$, $C_{\text{RAMP}} = 150\text{pF}$, $V_{\text{CC}} = 11\text{V}$ and $T_A = T_J$.

PARAMETER	TEST CONDITIONS	Min	Typ	Max	Units
Line Sense					
Vth High Line Comparator		3.9	4	4.1	V
Vth Low Line Comparator		0.96	1	1.04	V
lib (VFWD)			0	± 100	nA
Oscillator					
Frequency		90	100	110	kHz
Ramp Generator					
$I_{\text{RAMP}}/I_{\text{SLOPE}}$		9	10	11	A/A
$-I_{\text{RAMP}}/I_{\text{SET}}$		9	10	11	A/A
Peak Ramp Voltage		3.8	4	4.2	V
Valley Ramp Voltage		0.95	1	1.05	V
ISET Voltage Level		0.95	1	1.05	V
Soft Start					
Saturation	$V_{\text{CC}} = 11\text{V}$, VCC Comparator Off		25	100	mV
$I_{\text{SOFTST}}/I_{\text{SET}}$		0.8	1	1.2	A/A
Pulse Width Modulator					
lib(FEEDBK)			0	± 100	nA
FEEDBK	Zero Duty Cycle	0.9	1	1.1	V
	Maximum Duty Cycle, (Note 1)	3.8	4	4.2	V
Current Limit					
lib(CURLIM)			0	± 100	nA
Vth Current Limit		180	200	220	mV
Vth Shutdown		500	600	700	mV
Fault Counter					
Vth		3.8	4	4.2	V
Vsat			0	100	mV
$I_{\text{COUNT}}/I_{\text{SET}}$		0.8	1	1.2	A/A
Output Driver					
Vsat High	$I_{\text{OUT}} = -100\text{mA}$		0.4	1	V
Vsat Low	$I_{\text{OUT}} = 100\text{mA}$		0.4	1	V
Rise/Fall Time	$C_{\text{OUT}} = 1\text{nF}$, (Note 1)		20	100	ns

Note 1: This parameter guaranteed by design but not 100% tested in production.

PIN DESCRIPTIONS

VCC: Chip supply voltage pin. Bypass to PGND with a low ESL/ESR $0.1\mu\text{F}$ capacitor plus a capacitor for gate charge storage. Lead lengths must be minimum.

PGND: Ground pin for the output driver. Keep connections less than 2cm. Carefully maintain low impedance path for high current return.

OUT: Gate drive output pin. Connect to the gate of a power MOSFET with a resistor greater than 2Ω . Keep connection lengths under 2cm.

VFWD: Voltage Feed Forward and Line Sense pin. Connect to input DC line using a resistive divider.

SLOPE: Program the charging current for RAMP with a resistor from this pin to GND. This pin will follow VFWD.

FEEDBK: Input to the pulse width modulator comparator. Drive this pin with an optocoupler to GND and a resistor to VREF. Modulation input range is from 1V to 4V.

ISET: A resistor from this pin to GND programs RAMP discharge current, FREQ current, SOFTST current, and COUNT current.

PIN DESCRIPTIONS (cont.)

RAMP: Ramp Pin. Connect a capacitor to GND. Rising slope is programmed by current in SLOPE. This slope is compared to FEEDBK for pulse width modulation. The falling slope is programmed by the current in ISET and used to limit maximum duty cycle.

FREQ: Oscillator pin. Program the frequency with a capacitor to GND.

VREF: Precision 5V reference, and bypass point for internal circuitry. Bypass this pin with a 1μF minimum capacitor to GND.

GND: Analog ground. Connect to a low impedance

ground plane containing all analog low current returns.

SOFTST: Soft start pin. Program with a capacitor to GND.

COUNT: Program the time that fault events will be tolerated before shutdown occurs with a capacitor and resistor to GND.

CURLIM: Current Limit Sense pin. Terminates OUT gate drive pulse for inputs over 0.2V. Enables fault counting function (COUNT). For inputs over 0.6V, the shutdown latch is activated.

APPLICATION INFORMATION

(Note: Refer to Typical Application for external component names.) All the equations given below should be considered as first order approximations with final values determined empirically for a specific application.

Power Sequencing

VCC normally connects through a high impedance (R5) to the rectified line, with an additional path(R6) to a low voltage, bootstrap on the winding power transformer. VFWD normally connects to a divider (R1 and R2) from the rectified line. For circuit activation, all of the following considerations are required:

1. VFWD between 1V and 4V
2. VCC has been under 9V (to reset the shutdown latch)
3. VCC over 13V

At this time, the circuit will activate. I_{VCC} will increase from its start up value of 85μA to its run value of 1mA. The capacitor on SOFTST is charged with a current determined by:

$$-I_{SOFTST} = \frac{1V}{R4}$$

When SOFTST rises above 1V, output pulses will begin and I_{VCC} will further rise to a level dictated by gate charge requirements as $I_{VCC} \approx 1mA + QTfs$. With output pulses, the low voltage bootstrap winding should now power the controller. If VCC falls below 9V, the controller will turn off and the start sequence will reset and retry.

VCC Clamp

An internal shunt regulator clamps VCC so that it will not exceed 15V.

Output Inhibit

During normal operation, OUT is driven high at the start of a clock period and back low when RAMP either crosses FEEDBK or equals 4V. If, however, any of the following occur, OUT is immediately driven low for the remainder of the clock period:

1. VFWD is outside the range of 1V to 4V
2. CURLIM is greater than 0.2V
3. FEEDBK or SOFTST is less than 1V

Normal output pulses will not resume until the beginning of the next clock period in which none of the above conditions exist.

Current Limiting

CURLIM is monitored by two internal comparators. The current limit comparator threshold is 0.2V. If the current limit comparator is triggered, OUT is immediately driven low and held low for the remainder of the clock cycle, providing pulse-by-pulse overcurrent control for excessive loads. This comparator also causes CF to be charged for the remainder of the clock cycle. The charging current is

$$-I_{COUNT} = \frac{1V}{R4}$$

If repetitive cycles are terminated by the current limit comparator causing COUNT to rise above 4V, the shutdown latch is set. The COUNT integration delay feature will be bypassed by the shutdown comparator which has a 0.6V threshold. The shutdown comparator immediately sets the shutdown latch. R_F in parallel with C_F resets the COUNT integrator following transient faults. R_F must be greater than $\frac{(4 \bullet R4)}{(1 - D_{MAX})}$.

APPLICATION INFORMATION (cont.)

Latched Shutdown

If CURLIM rises above 0.6V, or COUNT rises to 4V, the shutdown latch will be set. This will force OUT low, discharge SOFTST and COUNT, and reduce I_{VCC} to approximately 1mA. When, and if, VCC falls below 9V, the shutdown latch will reset and I_{VCC} will fall to 85 μ A, allowing the circuit to restart. If VCC remains above 9V, an alternate restart will occur if VFWD is momentarily reduced below 1V. External shutdown commands from any source may be added into either the COUNT or CURLIM pins.

Deadtime Control

The voltage waveform on RAMP has independently controlled rising and falling edges. At the start of the clock period, RAMP is at 1V and rises to 4V. It then discharges back to 1V and awaits the next clock period. OUT can only be high during the rising part of the waveform, while it is positively blanked off during the falling portion. Setting the $-dV/dt$ slope by R4 from ISET to GND establishes a minimum deadtime as:

$$t_d = 0.3 \cdot R_4 \cdot C_R$$

Choose R4 between 20k and 200k and C_R greater than 50pF. In order to have a pulse at OUT in the next clock period, RAMP must fall to 1V prior to the end of the current period. If it does not, OUT will remain low for the entire next clock period.

Voltage Feedforward

The $+dV/dt$ on RAMP is made proportional to line voltage. The slope is:

$$\frac{dV}{dt} = 10 \cdot \frac{VFWD}{(R_3 \cdot C_R)}$$

where VFWD is line voltage scaled by R1 and R2. Therefore, a changing line voltage will accomplish an immediate proportionate pulse width change without any action from the feedback amplifier. This will result in constant volt-second drive to the power transformer providing both international voltage operation, and excellent dynamic line regulation. VFWD is intended to operate over a 4:1 range (1V to 4V) with undervoltage and overvoltage sensors designed to drive OUT low if this range is exceeded. Choose R3 between 20k and 200k.

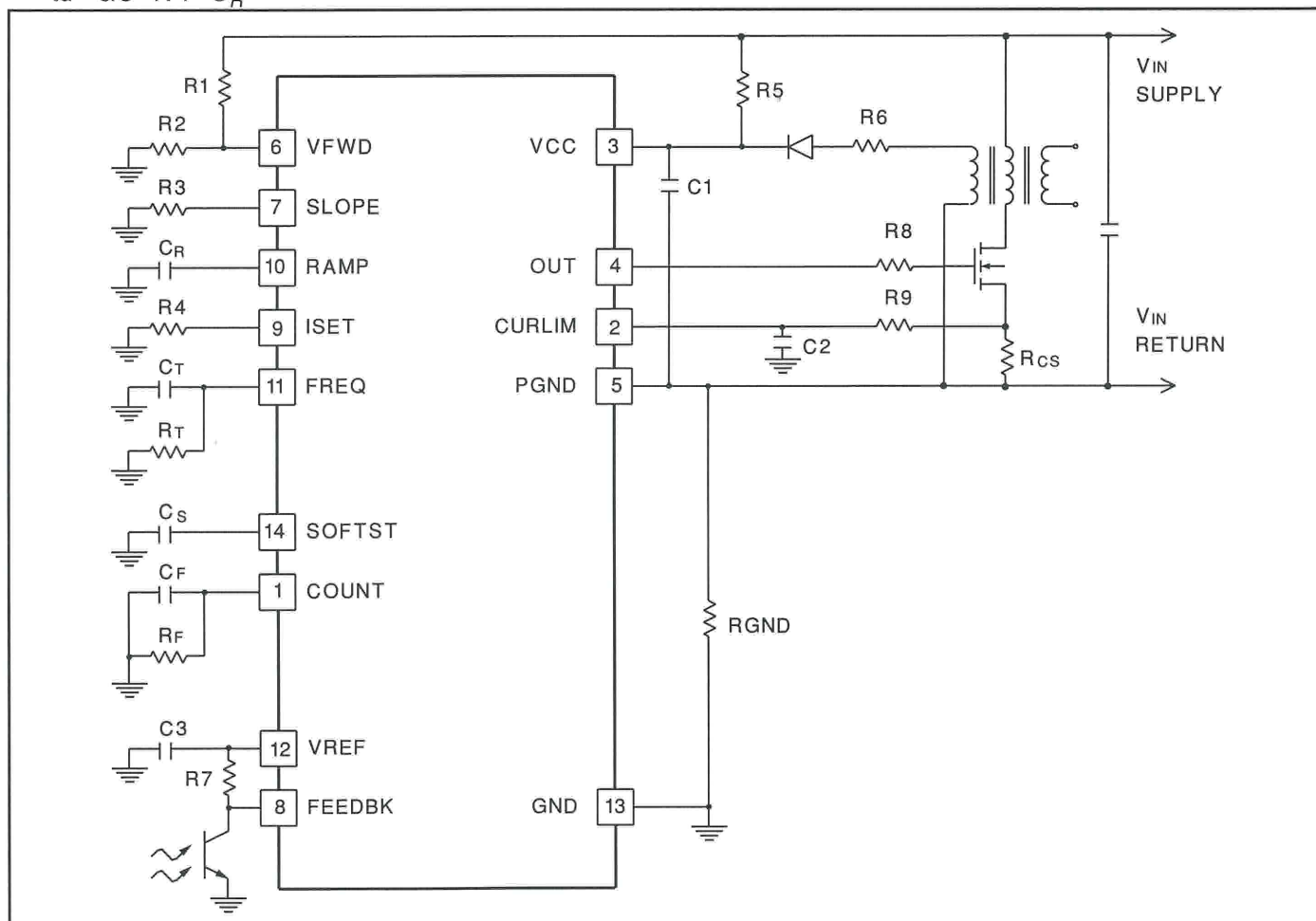

Figure 1. UCC1570 typical application.

APPLICATION INFORMATION (cont.)

Frequency Set

A capacitor from FREQ to GND will determine a constant clock frequency. Frequency is:

$$F = \frac{1.8}{(R4 \cdot C_T)}$$

If required, frequency can be trimmed down from the above equation by the addition of R_T from FREQ to GND. The reduction in frequency is a function of the ratio of $R_T/R4$. R_T should be greater than $2.4 \cdot R4$ for reliable operation.

External synchronization can be accomplished by coupling a narrow pulse to a resistor inserted in series with the ground side of C_T . The value should be less than $R4/200$ and the synchronizing pulse width should be less than 5% of the oscillator period.

External synchronization can also be accomplished by driving FREQ with an CMOS inverter. The inverter must

be able to sink $(4 \cdot I4)$ with at a voltage less than the 3.5V upper threshold of the oscillator. It must also be able to source $36 \cdot I4$ at a voltage greater than the 1.5V lower threshold of the oscillator. As long as FREQ is held high, the output is guaranteed to be low.

Gate Drive Output

The UCC1570 is capable of 1A peak output current. Bypass VCC with at least $0.1\mu F$ directly to PGND. Use a capacitor with low equivalent series resistance and inductance. The connection from OUT to the MOSFET gate should have a 2Ω or greater damping resistor and the length should be minimized. A low impedance connection must be established between the MOSFET source (or the ground side of the current sense resistor), the VCC bypass capacitor and PGND. PGND should then be connected by a single path (shown as RGND in the application) to GND.

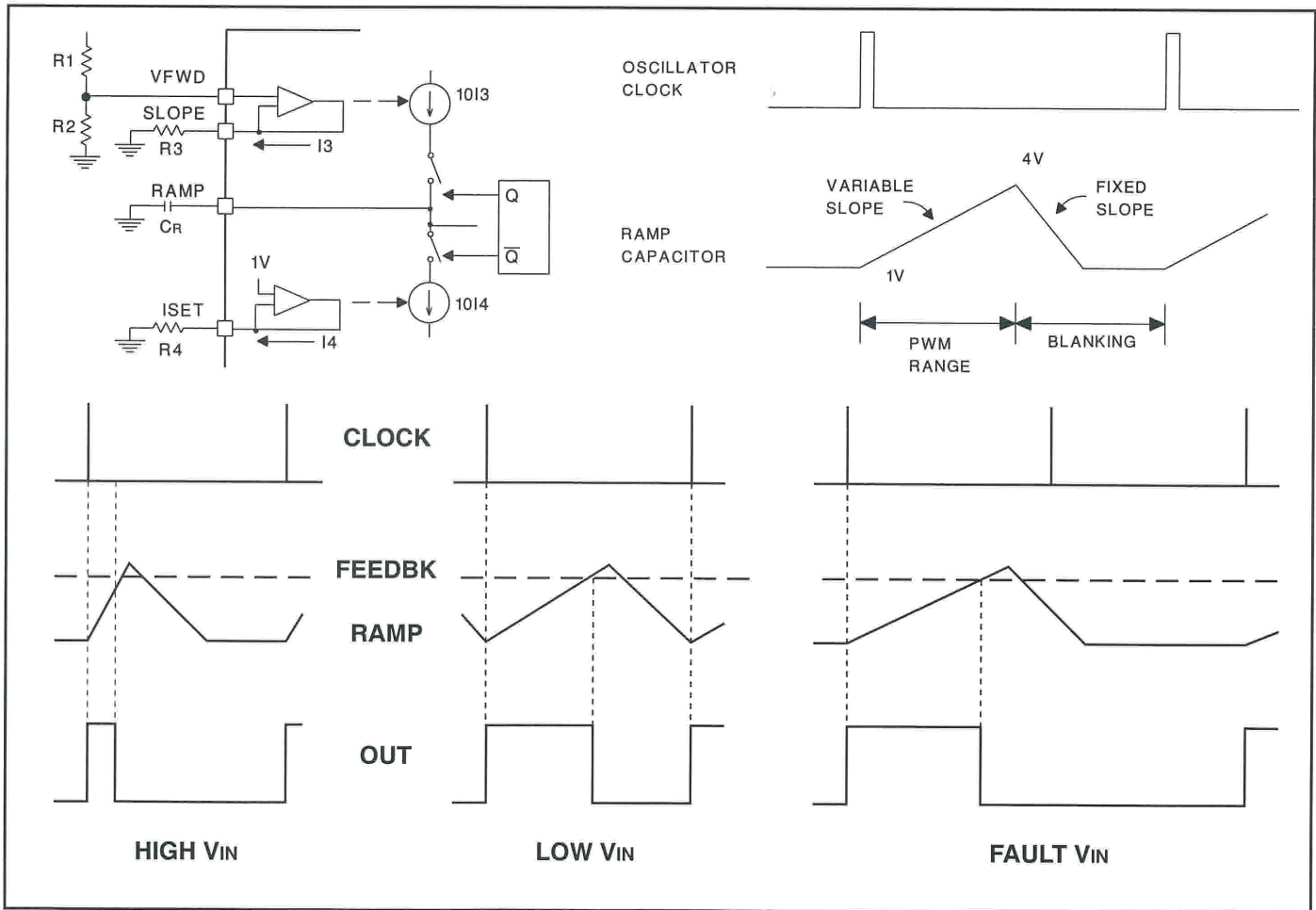

Figure 2. Ramp and PWM waveforms.

APPLICATION INFORMATION (cont.)

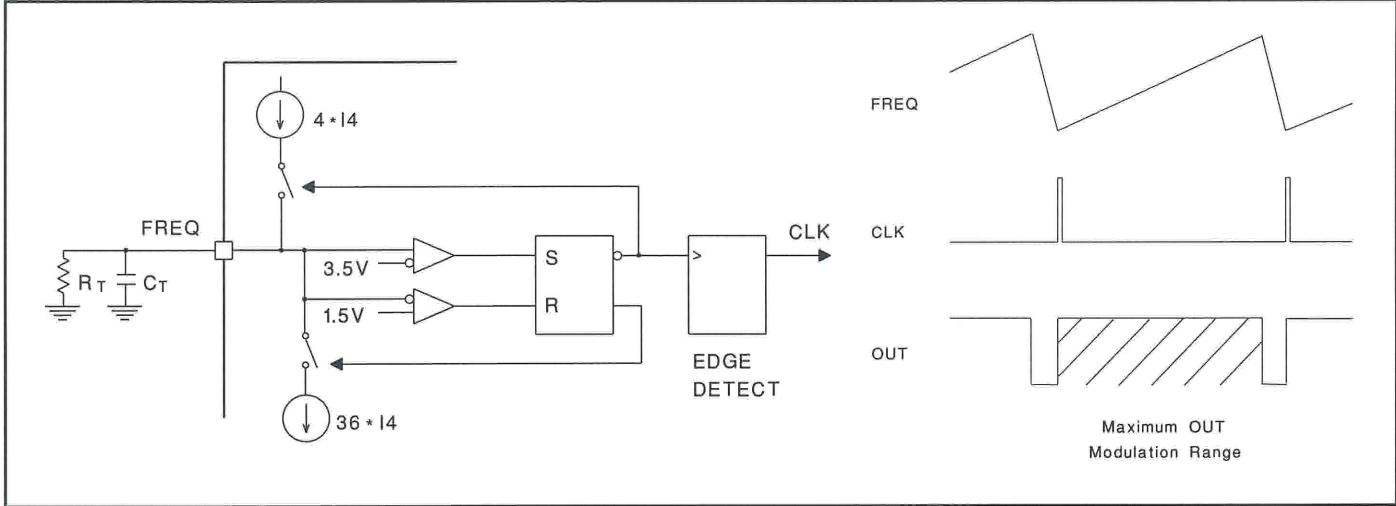

Figure 3. Clock generator.

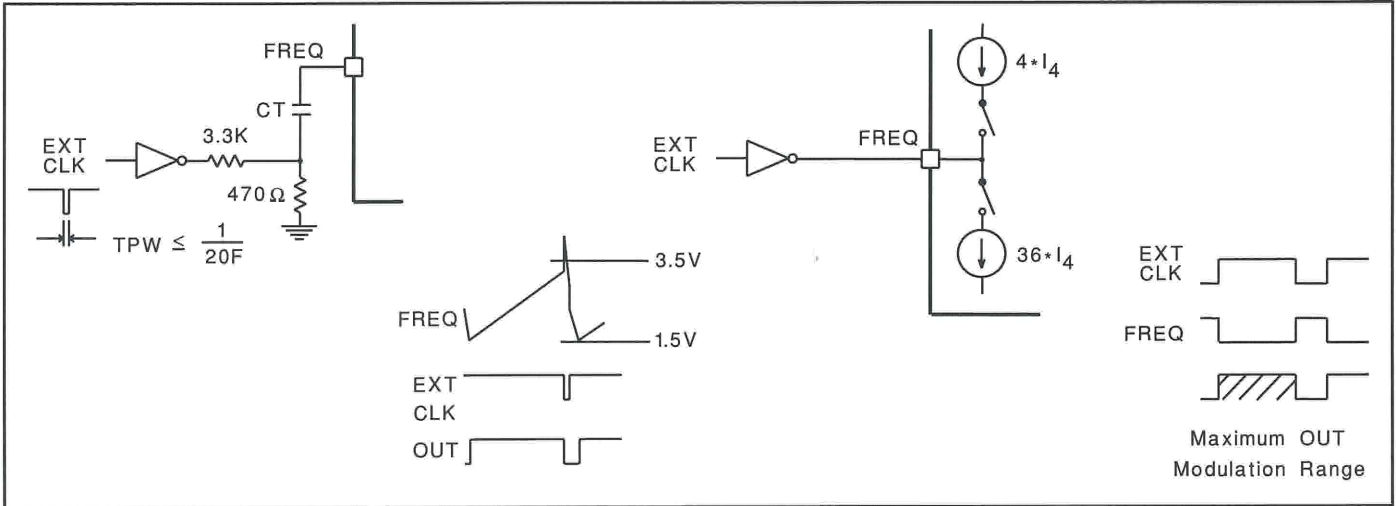

Figure 4. External clock synchronization.

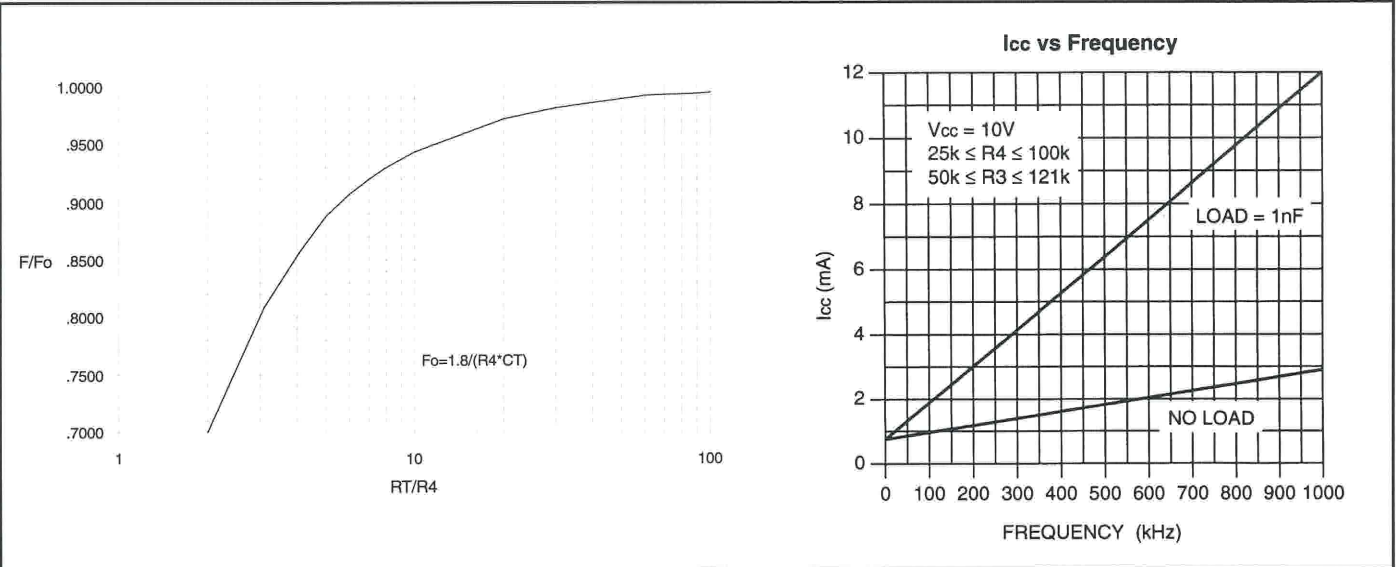
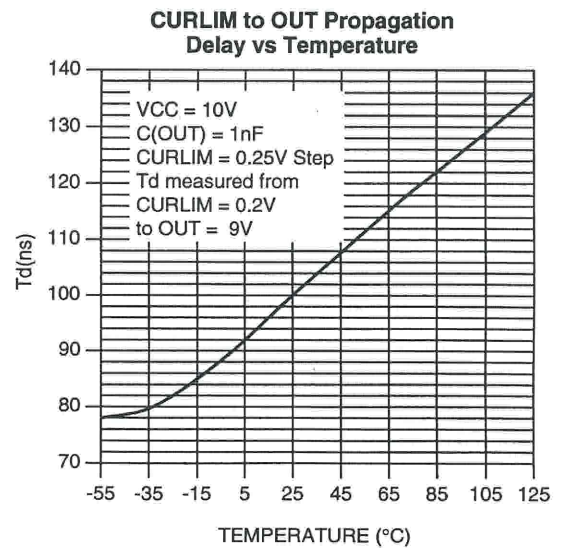
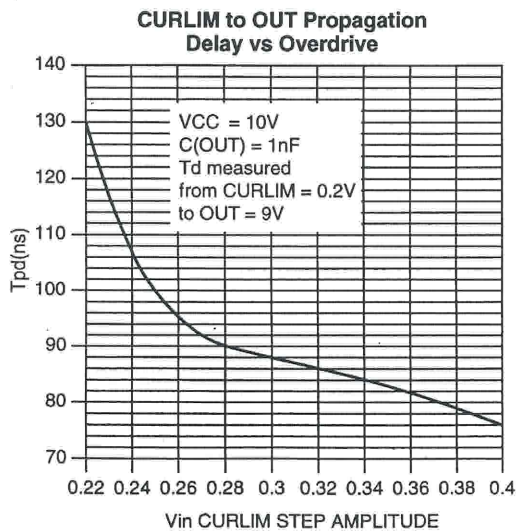
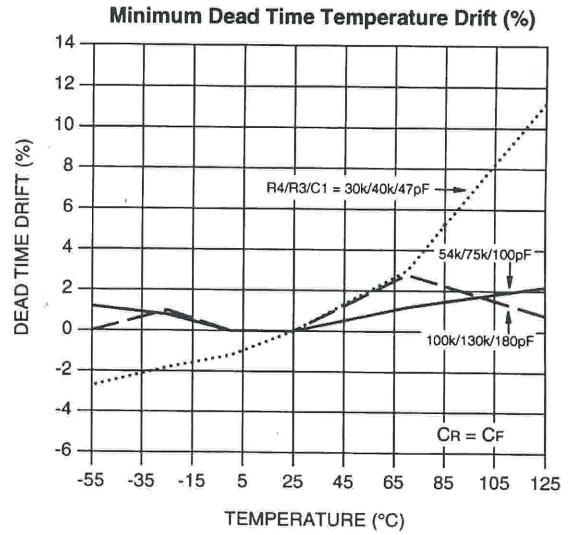
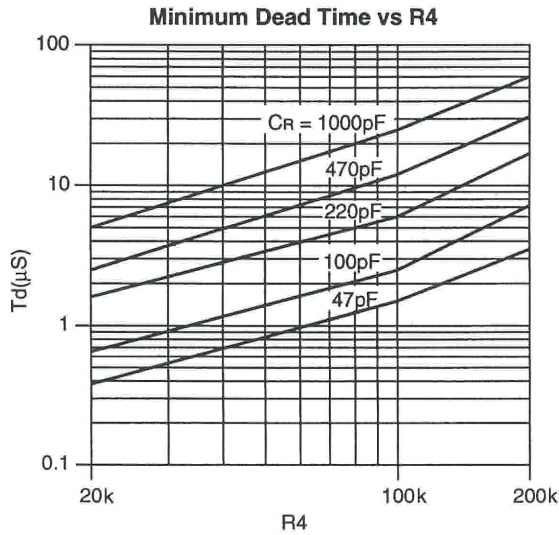
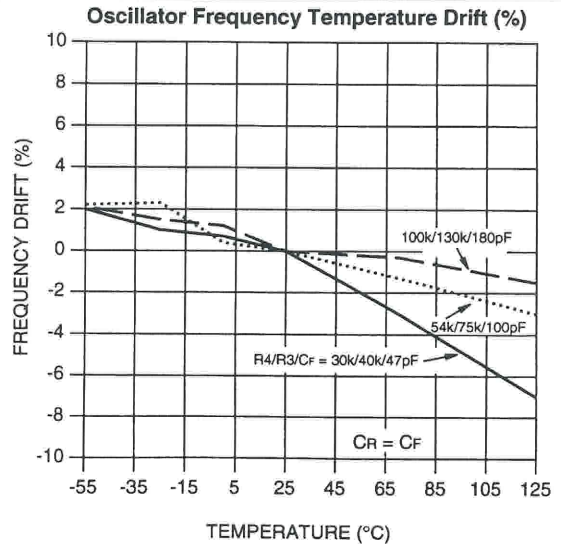
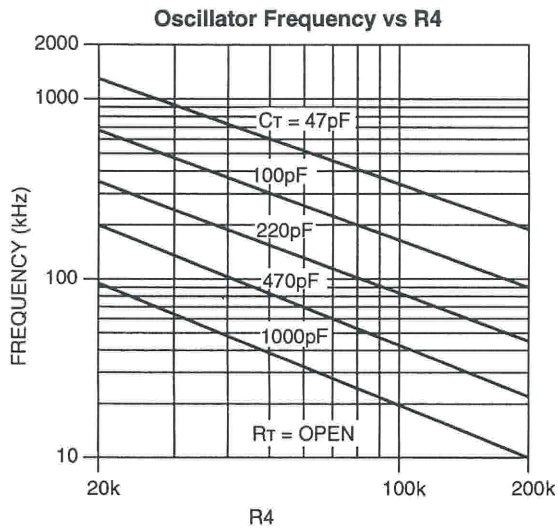

Figure 5. Frequency dependence on RT/ R4 ratio.

APPLICATION INFORMATION (cont.)



PACKAGING INFORMATION

Orderable Device	Status ⁽¹⁾	Package Type	Package Drawing	Pins	Package Qty	Eco Plan ⁽²⁾	Lead/ Ball Finish	MSL Peak Temp ⁽³⁾	Samples (Requires Login)
UCC2570D	OBSOLETE	SOIC	D	14		TBD	Call TI	Call TI	
UCC2570DG4	OBSOLETE	SOIC	D	14		TBD	Call TI	Call TI	
UCC2570DTR	OBSOLETE	SOIC	D	14		TBD	Call TI	Call TI	
UCC2570DTRG4	OBSOLETE	SOIC	D	14		TBD	Call TI	Call TI	
UCC2570N	OBSOLETE	PDIP	N	14		TBD	Call TI	Call TI	
UCC2570NG4	OBSOLETE	PDIP	N	14		TBD	Call TI	Call TI	
UCC3570D	OBSOLETE	SOIC	D	14		TBD	Call TI	Call TI	
UCC3570DG4	OBSOLETE	SOIC	D	14		TBD	Call TI	Call TI	
UCC3570DTR	OBSOLETE	SOIC	D	14		TBD	Call TI	Call TI	
UCC3570DTRG4	OBSOLETE	SOIC	D	14		TBD	Call TI	Call TI	
UCC3570N	OBSOLETE	PDIP	N	14		TBD	Call TI	Call TI	
UCC3570NG4	OBSOLETE	PDIP	N	14		TBD	Call TI	Call TI	
UCC3570Q	OBSOLETE	PLCC	FN	20		TBD	Call TI	Call TI	
UCC3570QTR	OBSOLETE	PLCC	FN	20		TBD	Call TI	Call TI	

⁽¹⁾ The marketing status values are defined as follows:

ACTIVE: Product device recommended for new designs.

LIFEBUY: TI has announced that the device will be discontinued, and a lifetime-buy period is in effect.

NRND: Not recommended for new designs. Device is in production to support existing customers, but TI does not recommend using this part in a new design.

PREVIEW: Device has been announced but is not in production. Samples may or may not be available.

OBSOLETE: TI has discontinued the production of the device.

⁽²⁾ Eco Plan - The planned eco-friendly classification: Pb-Free (RoHS), Pb-Free (RoHS Exempt), or Green (RoHS & no Sb/Br) - please check <http://www.ti.com/productcontent> for the latest availability information and additional product content details.

TBD: The Pb-Free/Green conversion plan has not been defined.

Pb-Free (RoHS): TI's terms "Lead-Free" or "Pb-Free" mean semiconductor products that are compatible with the current RoHS requirements for all 6 substances, including the requirement that lead not exceed 0.1% by weight in homogeneous materials. Where designed to be soldered at high temperatures, TI Pb-Free products are suitable for use in specified lead-free processes.

Pb-Free (RoHS Exempt): This component has a RoHS exemption for either 1) lead-based flip-chip solder bumps used between the die and package, or 2) lead-based die adhesive used between the die and leadframe. The component is otherwise considered Pb-Free (RoHS compatible) as defined above.

Green (RoHS & no Sb/Br): TI defines "Green" to mean Pb-Free (RoHS compatible), and free of Bromine (Br) and Antimony (Sb) based flame retardants (Br or Sb do not exceed 0.1% by weight in homogeneous material)

⁽³⁾ MSL, Peak Temp. -- The Moisture Sensitivity Level rating according to the JEDEC industry standard classifications, and peak solder temperature.

Important Information and Disclaimer: The information provided on this page represents TI's knowledge and belief as of the date that it is provided. TI bases its knowledge and belief on information provided by third parties, and makes no representation or warranty as to the accuracy of such information. Efforts are underway to better integrate information from third parties. TI has taken and continues to take reasonable steps to provide representative and accurate information but may not have conducted destructive testing or chemical analysis on incoming materials and chemicals. TI and TI suppliers consider certain information to be proprietary, and thus CAS numbers and other limited information may not be available for release.

In no event shall TI's liability arising out of such information exceed the total purchase price of the TI part(s) at issue in this document sold by TI to Customer on an annual basis.

OTHER QUALIFIED VERSIONS OF UCC2570 :

- Automotive: [UCC2570-Q1](#)

NOTE: Qualified Version Definitions:

- Automotive - Q100 devices qualified for high-reliability automotive applications targeting zero defects

D (R-PDSO-G14)

PLASTIC SMALL OUTLINE

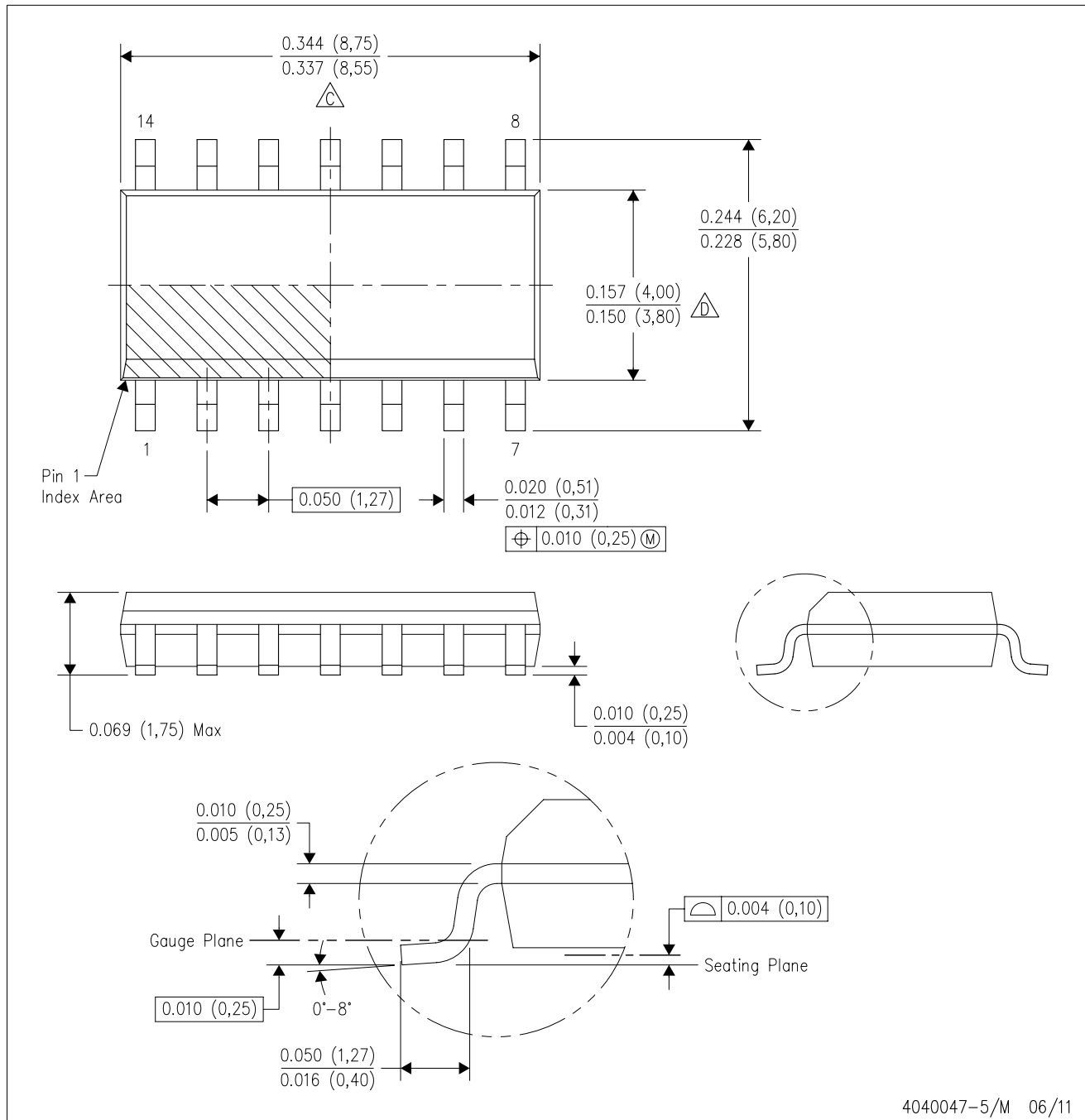

- NOTES:
- A. All linear dimensions are in inches (millimeters).
 - B. This drawing is subject to change without notice.
 - $\triangle C$ Body length does not include mold flash, protrusions, or gate burrs. Mold flash, protrusions, or gate burrs shall not exceed 0.006 (0,15) each side.
 - $\triangle D$ Body width does not include interlead flash. Interlead flash shall not exceed 0.017 (0,43) each side.
 - E. Reference JEDEC MS-012 variation AB.

FN (S-PQCC-J**)

PLASTIC J-LEADED CHIP CARRIER

20 PIN SHOWN

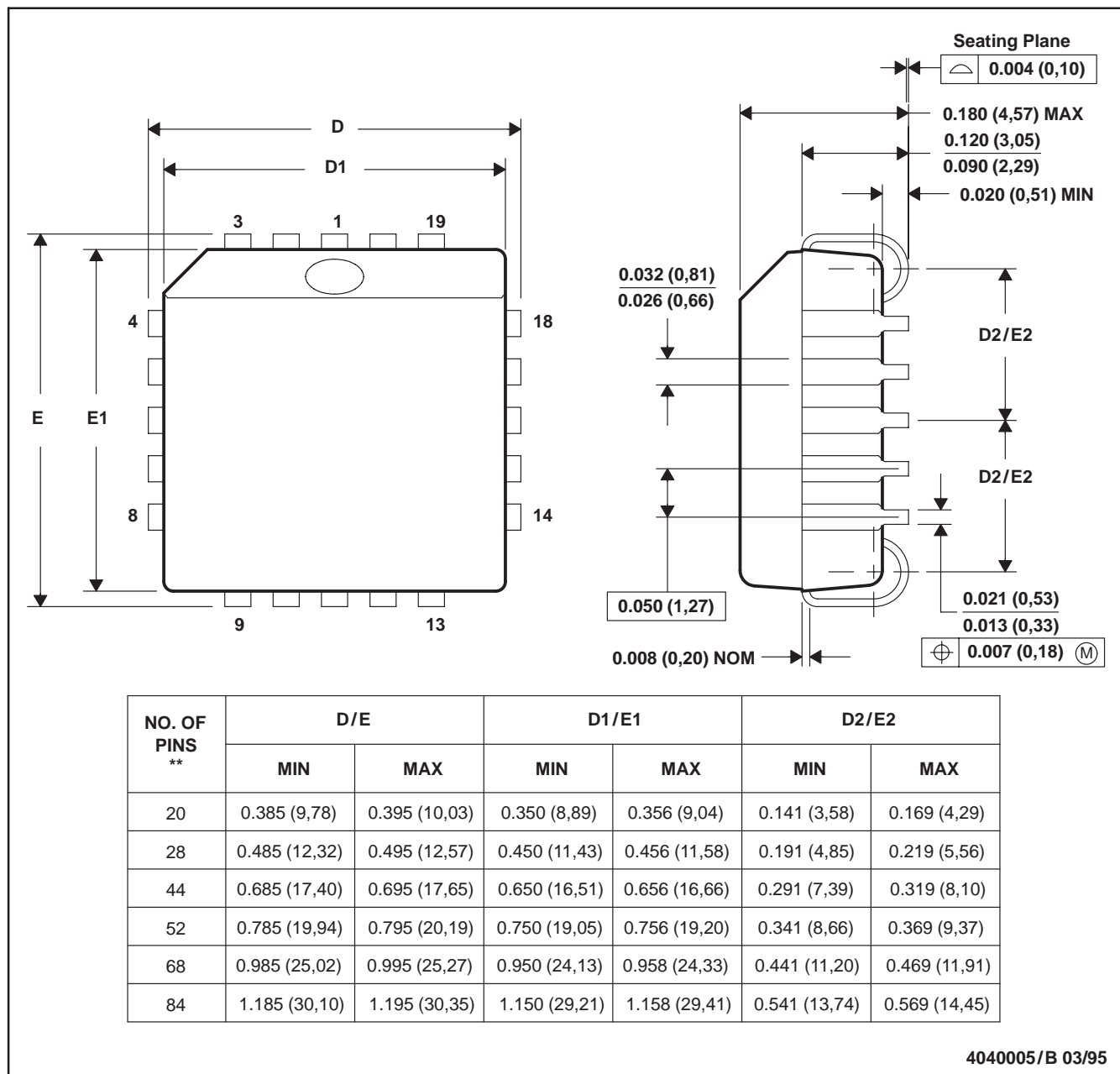

- NOTES: A. All linear dimensions are in inches (millimeters).
 B. This drawing is subject to change without notice.
 C. Falls within JEDEC MS-018

IMPORTANT NOTICE

Texas Instruments Incorporated and its subsidiaries (TI) reserve the right to make corrections, enhancements, improvements and other changes to its semiconductor products and services per JESD46, latest issue, and to discontinue any product or service per JESD48, latest issue. Buyers should obtain the latest relevant information before placing orders and should verify that such information is current and complete. All semiconductor products (also referred to herein as "components") are sold subject to TI's terms and conditions of sale supplied at the time of order acknowledgment.

TI warrants performance of its components to the specifications applicable at the time of sale, in accordance with the warranty in TI's terms and conditions of sale of semiconductor products. Testing and other quality control techniques are used to the extent TI deems necessary to support this warranty. Except where mandated by applicable law, testing of all parameters of each component is not necessarily performed.

TI assumes no liability for applications assistance or the design of Buyers' products. Buyers are responsible for their products and applications using TI components. To minimize the risks associated with Buyers' products and applications, Buyers should provide adequate design and operating safeguards.

TI does not warrant or represent that any license, either express or implied, is granted under any patent right, copyright, mask work right, or other intellectual property right relating to any combination, machine, or process in which TI components or services are used. Information published by TI regarding third-party products or services does not constitute a license to use such products or services or a warranty or endorsement thereof. Use of such information may require a license from a third party under the patents or other intellectual property of the third party, or a license from TI under the patents or other intellectual property of TI.

Reproduction of significant portions of TI information in TI data books or data sheets is permissible only if reproduction is without alteration and is accompanied by all associated warranties, conditions, limitations, and notices. TI is not responsible or liable for such altered documentation. Information of third parties may be subject to additional restrictions.

Resale of TI components or services with statements different from or beyond the parameters stated by TI for that component or service voids all express and any implied warranties for the associated TI component or service and is an unfair and deceptive business practice. TI is not responsible or liable for any such statements.

Buyer acknowledges and agrees that it is solely responsible for compliance with all legal, regulatory and safety-related requirements concerning its products, and any use of TI components in its applications, notwithstanding any applications-related information or support that may be provided by TI. Buyer represents and agrees that it has all the necessary expertise to create and implement safeguards which anticipate dangerous consequences of failures, monitor failures and their consequences, lessen the likelihood of failures that might cause harm and take appropriate remedial actions. Buyer will fully indemnify TI and its representatives against any damages arising out of the use of any TI components in safety-critical applications.

In some cases, TI components may be promoted specifically to facilitate safety-related applications. With such components, TI's goal is to help enable customers to design and create their own end-product solutions that meet applicable functional safety standards and requirements. Nonetheless, such components are subject to these terms.

No TI components are authorized for use in FDA Class III (or similar life-critical medical equipment) unless authorized officers of the parties have executed a special agreement specifically governing such use.

Only those TI components which TI has specifically designated as military grade or "enhanced plastic" are designed and intended for use in military/aerospace applications or environments. Buyer acknowledges and agrees that any military or aerospace use of TI components which have **not** been so designated is solely at the Buyer's risk, and that Buyer is solely responsible for compliance with all legal and regulatory requirements in connection with such use.

TI has specifically designated certain components as meeting ISO/TS16949 requirements, mainly for automotive use. In any case of use of non-designated products, TI will not be responsible for any failure to meet ISO/TS16949.

Products

Audio	www.ti.com/audio
Amplifiers	amplifier.ti.com
Data Converters	dataconverter.ti.com
DLP® Products	www.dlp.com
DSP	dsp.ti.com
Clocks and Timers	www.ti.com/clocks
Interface	interface.ti.com
Logic	logic.ti.com
Power Mgmt	power.ti.com
Microcontrollers	microcontroller.ti.com
RFID	www.ti-rfid.com
OMAP Applications Processors	www.ti.com/omap
Wireless Connectivity	www.ti.com/wirelessconnectivity

Applications

Automotive and Transportation	www.ti.com/automotive
Communications and Telecom	www.ti.com/communications
Computers and Peripherals	www.ti.com/computers
Consumer Electronics	www.ti.com/consumer-apps
Energy and Lighting	www.ti.com/energy
Industrial	www.ti.com/industrial
Medical	www.ti.com/medical
Security	www.ti.com/security
Space, Avionics and Defense	www.ti.com/space-avionics-defense
Video and Imaging	www.ti.com/video

TI E2E Community

e2e.ti.com

Looking for pricing, stock, or lifecycle information?

Click below to explore more details on WIN SOURCE:

 [View UCC2570DTR](#) on WIN SOURCE

 [Texas Instruments](#) Information

Optimize Your Supply Chain with WIN SOURCE Solutions

-  Global Sourcing Solution
-  Obsolete Management
-  Cost Control Management
-  Shortage Management
-  Alternative Solution
-  Excess Inventory Management