



THE DATASHEET OF 4N38SD



DESCRIPTION

The H11DX and 4N38 are phototransistor-type optically coupled optoisolators. An infrared emitting diode manufactured from specially grown gallium arsenide is selectively coupled with a high voltage NPN silicon phototransistor. The device is supplied in a standard plastic six-pin dual-in-line package.

H11D1
H11D2
H11D3
H11D4
4N38

FEATURES

- High Voltage
 - H11D1, H11D2, $BV_{CER} = 300\text{ V}$
 - H11D3, H11D4, $BV_{CER} = 200\text{ V}$
- High isolation voltage
 - 5300 VAC RMS - 1 minute
 - 7500 VAC PEAK - 1 minute
- Underwriters Laboratory (UL) recognized File# E90700

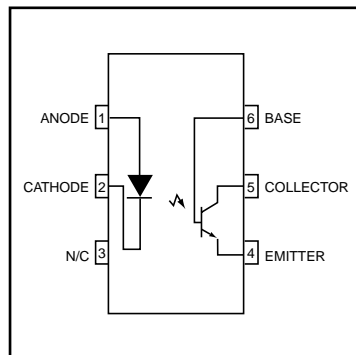
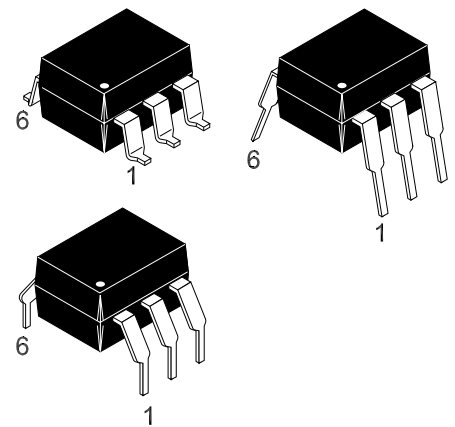

APPLICATIONS

- Power supply regulators
- Digital logic inputs
- Microprocessor inputs
- Appliance sensor systems
- Industrial controls

ABSOLUTE MAXIMUM RATINGS

Parameter	Symbol	Value	Units
TOTAL DEVICE			
Storage Temperature	T_{STG}	-55 to +150	°C
Operating Temperature	T_{OPR}	-55 to +100	°C
Lead Solder Temperature	T_{SOL}	260 for 10 sec	°C
Total Device Power Dissipation @ $T_A = 25^\circ\text{C}$	P_D	260	mW
Derate above 25°C		3.5	mW/°C
EMITTER			
*Forward DC Current	I_F	80	mA
*Reverse Input Voltage	V_R	6.0	V
*Forward Current - Peak (1 μs pulse, 300pps)	$I_F(pk)$	3.0	A
*LED Power Dissipation @ $T_A = 25^\circ\text{C}$	P_D	150	mW
Derate above 25°C		1.41	mW/°C

H11D1, H11D2, H11D3, H11D4, 4N38

ABSOLUTE MAXIMUM RATINGS (Cont.)			
Parameter	Symbol	Value	Units
DETECTOR			
*Power Dissipation @ $T_A = 25^\circ\text{C}$	P_D	300	mW
Derate linearly above 25°C		4.0	mW/ $^\circ\text{C}$
*Collector to Emitter Voltage	V_{CER}	H11D1 - H11D2 300	V
		H11D3 - H11D4 200	
		4N38 80	
*Collector Base Voltage	V_{CBO}	H11D1 - H11D2 300	
		H11D3 - H11D4 200	
		4N38 80	
*Emitter to Collector Voltage	V_{ECO}	7	
Collector Current (Continuous)		100	mA

ELECTRICAL CHARACTERISTICS ($T_A = 25^\circ\text{C}$ Unless otherwise specified.)

INDIVIDUAL COMPONENT CHARACTERISTICS							
Characteristic	Test Conditions	Symbol	Device	Min	Typ**	Max	Unit
EMITTER							
*Forward Voltage	($I_F = 10\text{ mA}$)	V_F	ALL		1.15	1.5	V
Forward Voltage Temp. Coefficient		$\frac{\Delta V_F}{\Delta T_A}$	ALL		-1.8		mV/ $^\circ\text{C}$
Reverse Breakdown Voltage	($I_R = 10\ \mu\text{A}$)	BV_R	ALL	6	25		V
Junction Capacitance	($V_F = 0\text{ V}, f = 1\text{ MHz}$)	C_J	ALL		50		pF
	($V_F = 1\text{ V}, f = 1\text{ MHz}$)		ALL		65		pF
*Reverse Leakage Current	($V_R = 6\text{ V}$)	I_R	ALL		0.05	10	μA
DETECTOR							
*Breakdown Voltage Collector to Emitter	($R_{BE} = 1\text{ M}\Omega$)	BV_{CER}	H11D1/2	300			V
	($I_C = 1.0\text{ mA}, I_F = 0$)		H11D3/4	200			
	(No R_{BE}) ($I_C = 1.0\text{ mA}$)	BV_{CEO}	4N38	80			
*Collector to Base	($I_C = 100\ \mu\text{A}, I_F = 0$)	BV_{CBO}	H11D1/2	300			
			H11D3/4	200			
			4N38	80			
Emitter to Base		BV_{EBO}	4N38	7			
Emitter to Collector	($I_E = 100\ \mu\text{A}, I_F = 0$)	BV_{ECO}	ALL	7	10		
*Leakage Current Collector to Emitter ($R_{BE} = 1\text{ M}\Omega$)	($V_{CE} = 200\text{ V}, I_F = 0, T_A = 25^\circ\text{C}$)	I_{CER}	H11D1/2			100	nA
	($V_{CE} = 200\text{ V}, I_F = 0, T_A = 100^\circ\text{C}$)					250	μA
	($V_{CE} = 100\text{ V}, I_F = 0, T_A = 25^\circ\text{C}$)		H11D3/4			100	nA
	($V_{CE} = 100\text{ V}, I_F = 0, T_A = 100^\circ\text{C}$)					250	μA
	(No R_{BE}) ($V_{CE} = 60\text{ V}, I_F = 0, T_A = 25^\circ\text{C}$)			I_{CEO}	4N38		

Notes

* Parameters meet or exceed JEDEC registered data (for 4N38 only)

 ** All typical values at $T_A = 25^\circ\text{C}$

H11D1, H11D2, H11D3, H11D4, 4N38

TRANSFER CHARACTERISTICS							
DC Characteristic	Test Conditions	Symbol	Device	Min	Typ**	Max	Unit
EMITTER							
Current Transfer Ratio Collector to Emitter	$(I_F = 10 \text{ mA}, V_{CE} = 10 \text{ V})$ $(R_{BE} = 1 \text{ M}\Omega)$	CTR	H11D1	2 (20)			mA (%)
			H11D2				
			H11D3				
			H11D4	1 (10)			
			4N38	2 (20)			
*Saturation Voltage	$(I_F = 10 \text{ mA}, I_C = 0.5 \text{ mA})$ $(R_{BE} = 1 \text{ M}\Omega)$	$V_{CE(SAT)}$	H11D1/2/3/4		0.1	0.40	V
			4N38			1.0	
	$(I_F = 20 \text{ mA}, I_C = 4 \text{ mA})$						

TRANSFER CHARACTERISTICS							
Characteristic	Test Conditions	Symbol	Device	Min	Typ**	Max	Unit
SWITCHING TIMES							
Non-Saturated Turn-on Time	$(V_{CE} = 10 \text{ V}, I_{CE} = 2 \text{ mA})$	t_{on}	ALL		5		μs
Turn-off Time	$(R_L = 100 \Omega)$	t_{off}	ALL		5		

ISOLATION CHARACTERISTICS							
Characteristic	Test Conditions	Symbol	Device	Min	Typ**	Max	Unit
Isolation Voltage	$(I_{I-O} \leq 1 \mu\text{A}, 1 \text{ min.})$	V_{ISO}	ALL	5300			(V_{ACRMS})
				7500			(V_{ACPEAK})
Isolation Resistance	$(V_{I-O} = 500 \text{ VDC})$	R_{ISO}	ALL	10^{11}			Ω
Isolation Capacitance	$(f = 1 \text{ MHz})$	C_{ISO}	ALL		0.5		pF

Notes
 * Parameters meet or exceed JEDEC registered data (for 4N38 only)
 ** All typical values at $T_A = 25^\circ\text{C}$

Fig.1 LED Forward Voltage vs. Forward Current

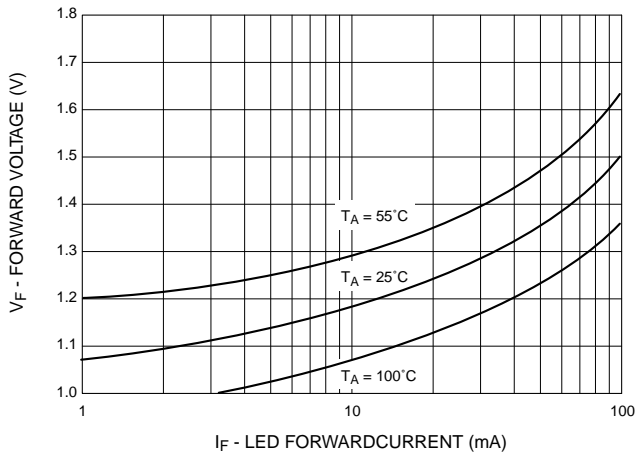
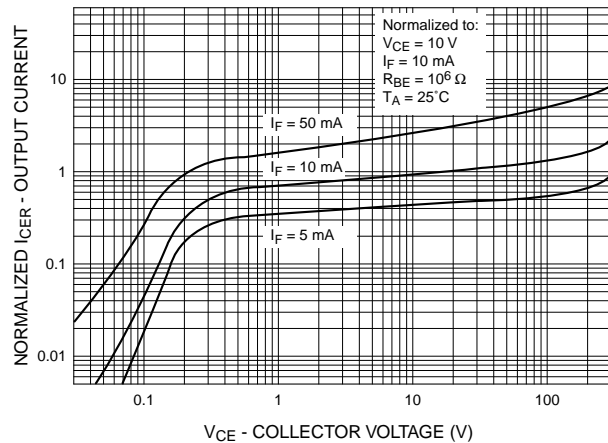

Fig.2 Normalized Output Characteristics



H11D1, H11D2, H11D3, H11D4, 4N38

Fig.3 Normalized Output Current vs. LED Input Current

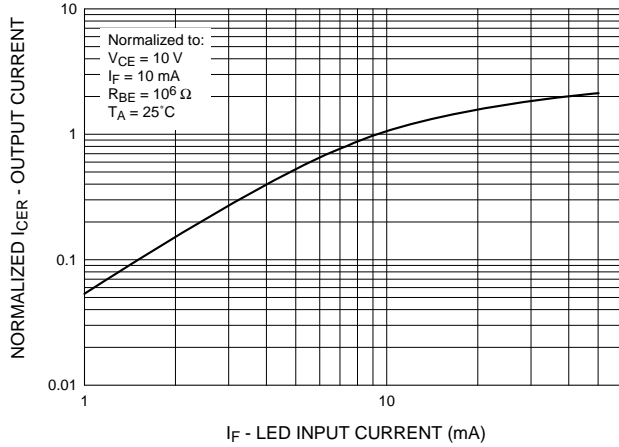

Fig.4 Normalized Output Current vs. Temperature

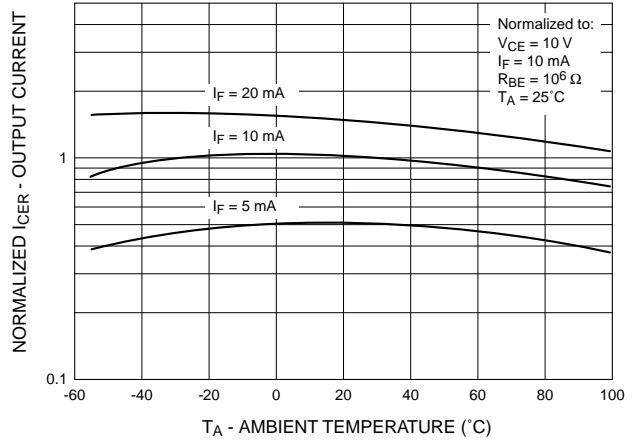
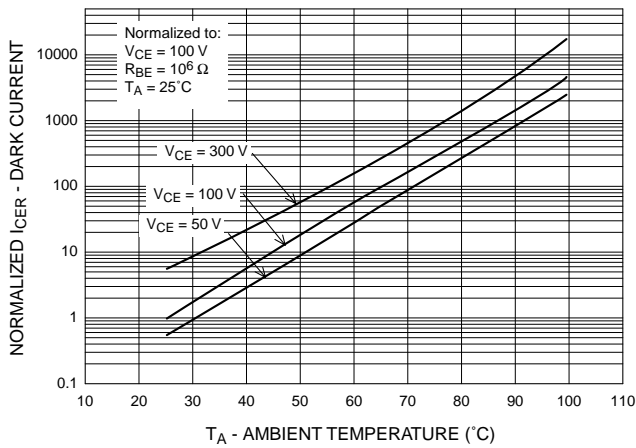
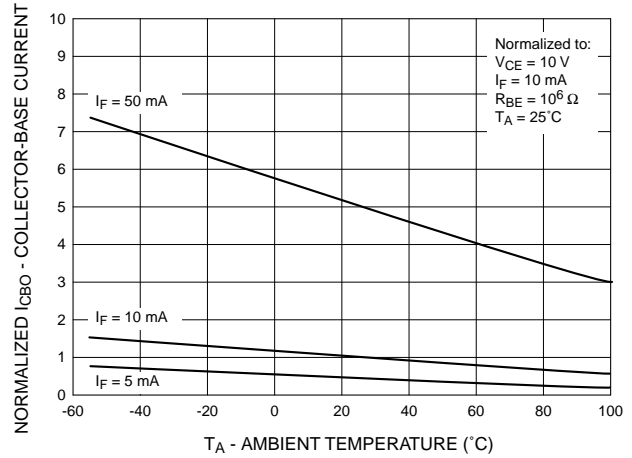

Fig.5 Normalized Dark Current vs. Ambient Temperature



Normalized Collector-Base Current vs. Temperature



H11D1, H11D2, H11D3, H11D4, 4N38

Package Dimensions (Through Hole)

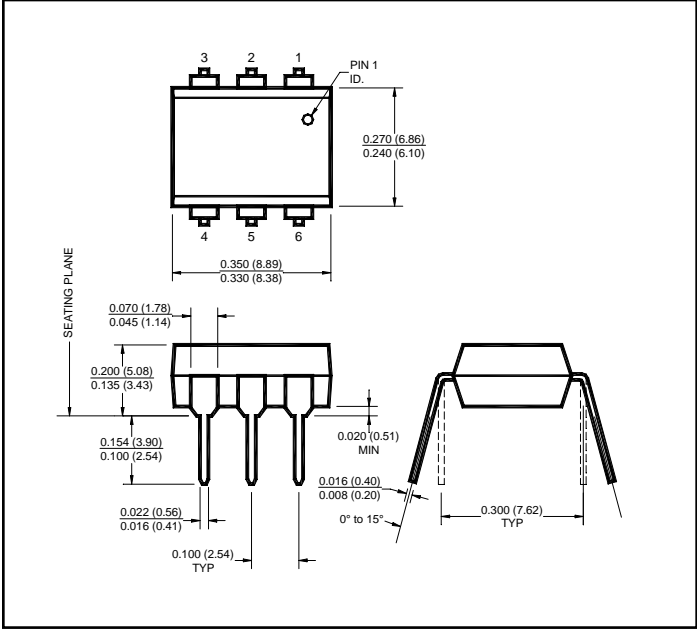

Package Dimensions (Surface Mount)

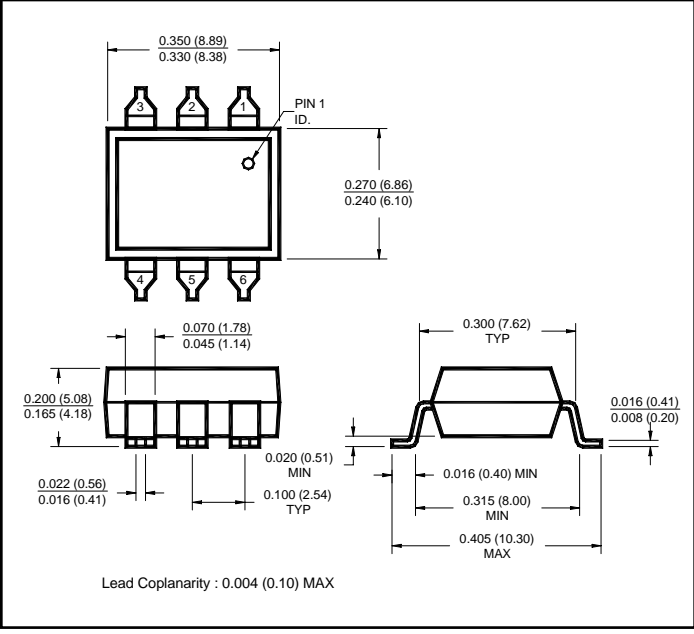

Package Dimensions (0.4" Lead Spacing)

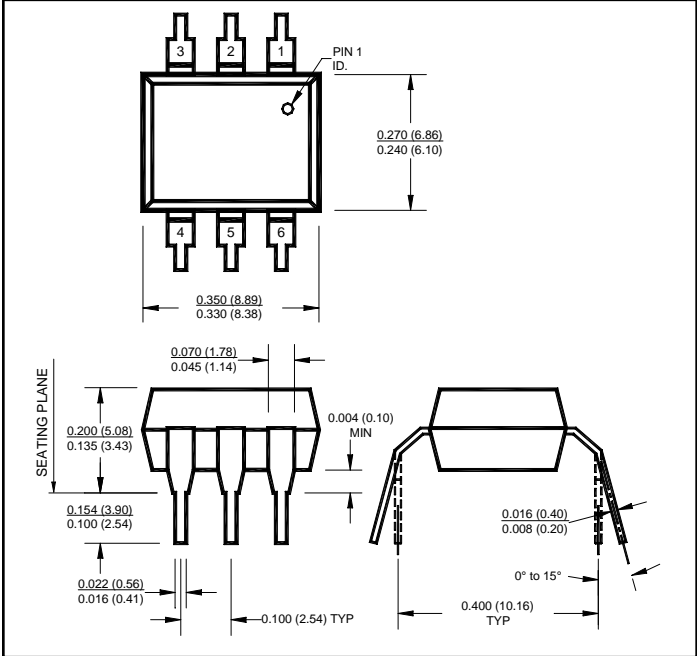

Recommended Pad Layout for Surface Mount Leadform

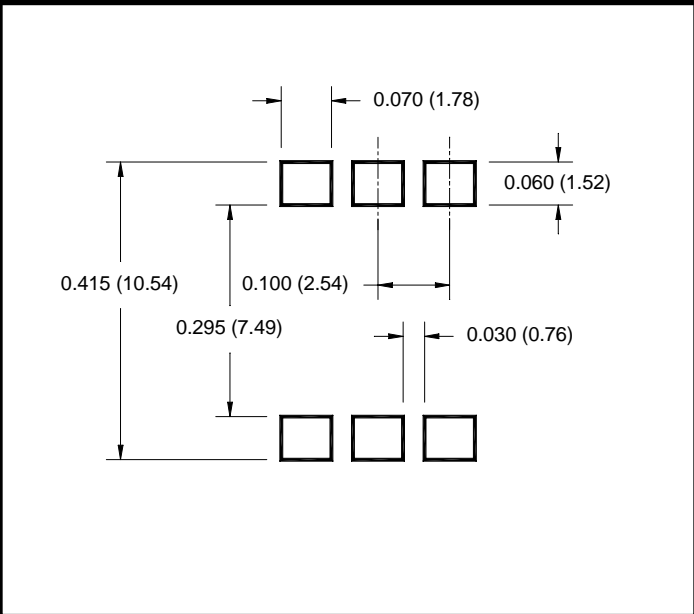

NOTE

All dimensions are in inches (millimeters)

H11D1, H11D2, H11D3, H11D4, 4N38

ORDERING INFORMATION

Option	Order Entry Identifier	Description
S	.S	Surface Mount Lead Bend
SD	.SD	Surface Mount; Tape and reel
W	.W	0.4" Lead Spacing
300	.300	VDE 0884
300W	.300W	VDE 0884, 0.4" Lead Spacing
3S	.3S	VDE 0884, Surface Mount
3SD	.3SD	VDE 0884, Surface Mount, Tape & Reel

QT Carrier Tape Specifications ("D" Taping Orientation)

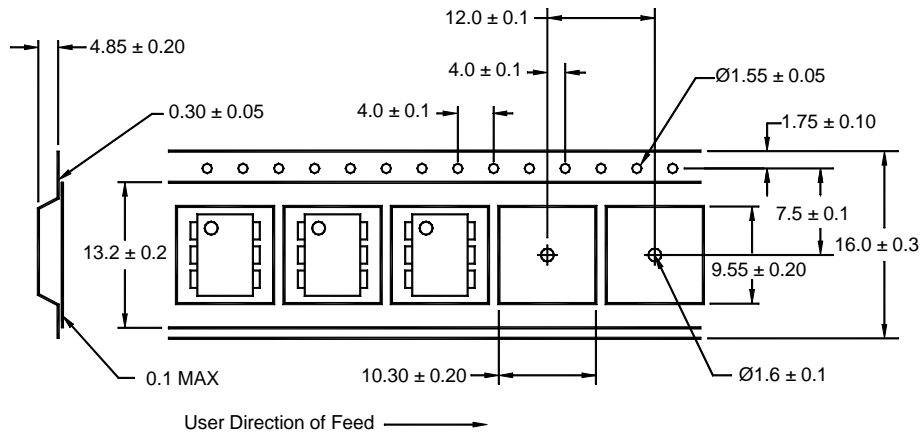

NOTE

All dimensions are in millimeters

MARKING INFORMATION

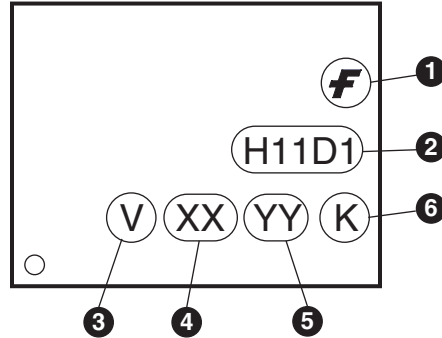

Definitions	
1	Fairchild logo
2	Device number
3	VDE mark (Note: Only appears on parts ordered with VDE option – See order entry table)
4	Two digit year code, e.g., '03'
5	Two digit work week ranging from '01' to '53'
6	Assembly package code

Reflow Profile (Black Package, No Suffix)

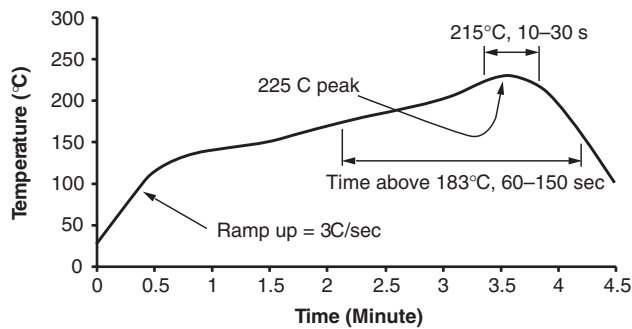

- Peak reflow temperature: 225°C (package surface temperature)
- Time of temperature higher than 183°C for 60–150 seconds
- One time soldering reflow is recommended

TRADEMARKS

The following are registered and unregistered trademarks Fairchild Semiconductor owns or is authorized to use and is not intended to be an exhaustive list of all such trademarks.

ACEx™	FAST®	ISOPLANAR™	Power247™	Stealth™
ActiveArray™	FASTr™	LittleFET™	PowerEdge™	SuperFET™
Bottomless™	FPST™	MICROCOUPLER™	PowerSaver™	SuperSOT™-3
CoolFET™	FRFET™	MicroFET™	PowerTrench®	SuperSOT™-6
CROSSVOLT™	GlobalOptoisolator™	MicroPak™	QFET®	SuperSOT™-8
DOMET™	GTO™	MICROWIRE™	QS™	SyncFET™
EcoSPARK™	HiSeC™	MSX™	QT Optoelectronics™	TinyLogic®
E ² CMOS™	μC™	MSXPro™	Quiet Series™	TINYOPTO™
EnSigna™	i-Lo™	OCX™	RapidConfigure™	TruTranslation™
FACT™	ImpliedDisconnect™	OCXPro™	RapidConnect™	UHC™
FACT Quiet Series™		OPTOLOGIC®	μSerDes™	UltraFET®
Across the board. Around the world.™		OPTOPLANAR™	SILENT SWITCHER®	VCX™
The Power Franchise®		PACMAN™	SMART START™	
Programmable Active Droop™		POP™	SPM™	

DISCLAIMER

FAIRCHILD SEMICONDUCTOR RESERVES THE RIGHT TO MAKE CHANGES WITHOUT FURTHER NOTICE TO ANY PRODUCTS HEREIN TO IMPROVE RELIABILITY, FUNCTION OR DESIGN. FAIRCHILD DOES NOT ASSUME ANY LIABILITY ARISING OUT OF THE APPLICATION OR USE OF ANY PRODUCT OR CIRCUIT DESCRIBED HEREIN; NEITHER DOES IT CONVEY ANY LICENSE UNDER ITS PATENT RIGHTS, NOR THE RIGHTS OF OTHERS.

LIFE SUPPORT POLICY

FAIRCHILD'S PRODUCTS ARE NOT AUTHORIZED FOR USE AS CRITICAL COMPONENTS IN LIFE SUPPORT DEVICES OR SYSTEMS WITHOUT THE EXPRESS WRITTEN APPROVAL OF FAIRCHILD SEMICONDUCTOR CORPORATION. As used herein:

1. Life support devices or systems are devices or systems which, (a) are intended for surgical implant into the body, or (b) support or sustain life, or (c) whose failure to perform when properly used in accordance with instructions for use provided in the labeling, can be reasonably expected to result in significant injury to the user.
2. A critical component is any component of a life support device or system whose failure to perform can be reasonably expected to cause the failure of the life support device or system, or to affect its safety or effectiveness.



PRODUCT STATUS DEFINITIONS

Definition of Terms

Datasheet Identification	Product Status	Definition
Advance Information	Formative or In Design	This datasheet contains the design specifications for product development. Specifications may change in any manner without notice.
Preliminary	First Production	This datasheet contains preliminary data, and supplementary data will be published at a later date. Fairchild Semiconductor reserves the right to make changes at any time without notice in order to improve design.
No Identification Needed	Full Production	This datasheet contains final specifications. Fairchild Semiconductor reserves the right to make changes at any time without notice in order to improve design.
Obsolete	Not In Production	This datasheet contains specifications on a product that has been discontinued by Fairchild semiconductor. The datasheet is printed for reference information only.

Looking for pricing, stock, or lifecycle information?

Click below to explore more details on WIN SOURCE:

-  [View 4N38SD on WIN SOURCE](#)
-  [Fairchild/ON Semiconductor](#) Information

Optimize Your Supply Chain with WIN SOURCE Solutions

-  Global Sourcing Solution
-  Obsolete Management
-  Cost Control Management
-  Shortage Management
-  Alternative Solution
-  Excess Inventory Management