



**THE DATASHEET OF
LT5525EUF#PBF**



FEATURES

- Wide Input Frequency Range: 0.8GHz to 2.5GHz*
- Broadband LO and IF Operation
- High Input IP3: +17.6dBm at 1900MHz
- Typical Conversion Gain: -1.9dB at 1900MHz
- High LO-RF and LO-IF Isolation
- SSB Noise Figure: 15.1dB at 1900MHz
- Single-Ended 50Ω RF and LO Interface
- Integrated LO Buffer: -5dBm Drive Level
- Low Supply Current: 28mA Typ
- Enable Function
- Single 5V Supply
- 16-Lead QFN (4mm × 4mm) Package

APPLICATIONS

- Point-to-Point Data Communication Systems
- Wireless Infrastructure
- High Performance Radios
- High Linearity Receiver Applications

DESCRIPTION

The LT[®]5525 is a low power broadband mixer optimized for high linearity applications such as point-to-point data transmission, high performance radios and wireless infrastructure systems. The device includes an internally 50Ω matched high speed LO amplifier driving a double-balanced active mixer core. An integrated RF buffer amplifier provides excellent LO-RF isolation. The RF input balun and all associated 50Ω matching components are integrated. The IF ports can be easily matched across a broad range of frequencies for use in a wide variety of applications.

The LT5525 offers a high performance alternative to passive mixers. Unlike passive mixers, which require high LO drive levels, the LT5525 operates at significantly lower LO input levels and is much less sensitive to LO power level variations.

LT, LTC and LT are registered trademarks of Linear Technology Corporation.
 *Operation over a wider frequency range is achievable with reduced performance.
 Consult factory for more information.

TYPICAL APPLICATION

High Signal Level Frequency Downconversion

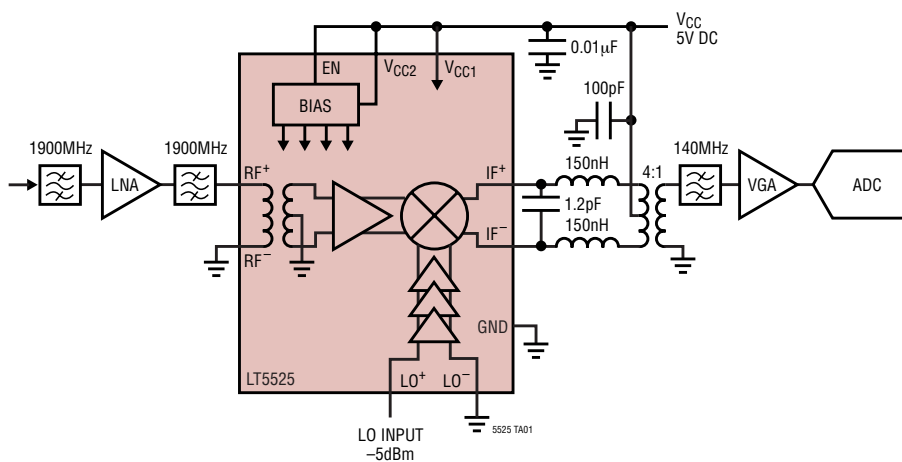

IF Output Power and IM3 vs
 RF Input Power (Two Input Tones)

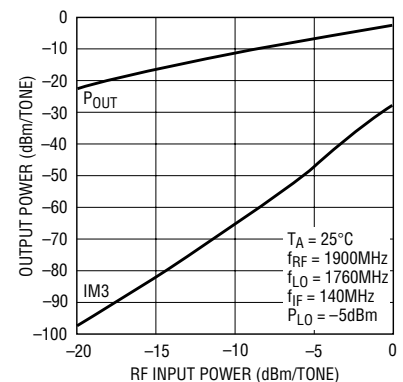

5525 TA02

ABSOLUTE MAXIMUM RATINGS

(Note 1)

Supply Voltage	5.5V
Enable Voltage	-0.3V to $V_{CC} + 0.3V$
LO Input Power	+10dBm
LO+ to LO- Differential DC Voltage	$\pm 1V$
LO+ and LO- Common Mode DC Voltage ...	-0.5V to V_{CC}
RF Input Power	+10dBm
RF+ to RF- Differential DC Voltage	$\pm 0.13V$
RF+ and RF- Common Mode DC Voltage ...	-0.5V to V_{CC}
IF+ and IF- Common Mode DC Voltage	5.5V
Operating Temperature Range	-40°C to 85°C
Storage Temperature Range	-65°C to 125°C
Junction Temperature (T_J)	125°C

PACKAGE/ORDER INFORMATION

<p>TOP VIEW</p> <p>16-LEAD (4mm x 4mm) PLASTIC QFN</p> <p>$T_{JMAX} = 125^{\circ}C$, $\theta_{JA} = 37^{\circ}C/W$ EXPOSED PAD (PIN 17) IS GND, MUST BE SOLDERED TO PCB. NC PINS SHOULD BE GROUNDED</p>	ORDER PART NUMBER LT5525EUF UF PART MARKING 5525
--	---

Consult LTC Marketing for parts specified with wider operating temperature ranges.

DC ELECTRICAL CHARACTERISTICS

$V_{CC} = 5V$, $EN = 3V$, $T_A = 25^{\circ}C$ (Note 3), unless otherwise noted. Test circuit shown in Figure 1.

PARAMETER	CONDITIONS	MIN	TYP	MAX	UNITS
Power Supply Requirements (V_{CC})					
Supply Voltage	(Note 6)	3.6	5	5.3	V
Supply Current	$V_{CC} = 5V$		28	33	mA
Shutdown Current	EN = Low			100	μA
Enable (EN) Low = Off, High = On					
EN Input High Voltage (On)		3			V
EN Input Low Voltage (Off)				0.3	V
Enable Pin Input Current	EN = 5V EN = 0V		55 0.1		μA μA
Turn-On Time (Note 5)			3		μS
Turn-Off Time (Note 5)			6		μS

AC ELECTRICAL CHARACTERISTICS (Notes 2, 3)

PARAMETER	CONDITIONS	MIN	TYP	MAX	UNITS
RF Input Frequency Range (Note 4)	Requires RF Matching Below 1300MHz		800 to 2500		MHz
LO Input Frequency Range (Note 4)			500 to 3000		MHz
IF Output Frequency Range (Note 4)	Requires IF Matching		0.1 to 1000		MHz

$V_{CC} = 5V$, $EN = 3V$, $T_A = 25^{\circ}C$. Test circuit shown in Figure 1. (Notes 2, 3)

PARAMETER	CONDITIONS	MIN	TYP	MAX	UNITS
RF Input Return Loss	$Z_0 = 50\Omega$		15		dB
LO Input Return Loss	$Z_0 = 50\Omega$, External DC Blocks		15		dB
IF Output Return Loss	$Z_0 = 50\Omega$, External Match		15		dB
LO Input Power			-10 to 0		dBm

AC ELECTRICAL CHARACTERISTICS $V_{CC} = 5V$, $EN = 3V$, $T_A = 25^{\circ}C$, $P_{RF} = -15dBm$ ($-15dBm/$ tone for 2-tone IIP3 tests, $\Delta f = 1MHz$), $f_{LO} = f_{RF} - 140MHz$, $P_{LO} = -5dBm$, IF output measured at 140MHz, unless otherwise noted. Test circuit shown in Figure 1. (Notes 2, 3)

PARAMETER	CONDITIONS	MIN	TYP	MAX	UNITS
Conversion Gain	$f_{RF} = 900MHz$		-2.6		dB
	$f_{RF} = 1900MHz$		-1.9		dB
	$f_{RF} = 2100MHz$		-2.0		dB
	$f_{RF} = 2500MHz$		-2.0		dB
Conversion Gain vs Temperature	$T_A = -40^{\circ}C$ to $85^{\circ}C$		-0.020		dB/ $^{\circ}C$
Input 3rd Order Intercept	$f_{RF} = 900MHz$		21.0		dBm
	$f_{RF} = 1900MHz$		17.6		dBm
	$f_{RF} = 2100MHz$		17.6		dBm
	$f_{RF} = 2500MHz$		12.0		dBm
Single Sideband Noise Figure	$f_{RF} = 900MHz$		14.0		dB
	$f_{RF} = 1900MHz$		15.1		dB
	$f_{RF} = 2100MHz$		15.6		dB
	$f_{RF} = 2500MHz$		15.6		dB
LO to RF Leakage	$f_{LO} = 500MHz$ to $1000MHz$		≤ -50		dBm
	$f_{LO} = 1000MHz$ to $3000MHz$		≤ -43		dBm
LO to IF Leakage	$f_{LO} = 500MHz$ to $1400MHz$		≤ -50		dBm
	$f_{LO} = 1400MHz$ to $3000MHz$		≤ -39		dBm
RF to LO Isolation	$f_{RF} = 500MHz$ to $3000MHz$		>38		dB
RF to IF Isolation	$f_{RF} = 900MHz$		62		dB
	$f_{RF} = 1900MHz$		42		dB
	$f_{RF} = 2100MHz$		40		dB
	$f_{RF} = 2500MHz$		33		dB
Input 1dB Compression	$f_{RF} = 900MHz$		7.6		dBm
	$f_{RF} = 1900MHz$		4		dBm
	$f_{RF} = 2100MHz$		4		dBm
	$f_{RF} = 2500MHz$		3		dBm
2RF-2LO Output Spurious Product ($f_{RF} = f_{LO} + f_{IF}/2$)	900MHz: $f_{RF} = 830MHz$ at $-15dBm$		-63		dBc
	1900MHz: $f_{RF} = 1830MHz$ at $-15dBm$		-53		dBc
	2100MHz: $f_{RF} = 2030MHz$ at $-15dBm$		-45		dBc
	2500MHz: $f_{RF} = 2430MHz$ at $-15dBm$		-42		dBc
3RF-3LO Output Spurious Product ($f_{RF} = f_{LO} + f_{IF}/3$)	900MHz: $f_{RF} = 806.67MHz$ at $-15dBm$		-74		dBc
	1900MHz: $f_{RF} = 1806.67MHz$ at $-15dBm$		-59		dBc
	2100MHz: $f_{RF} = 2006.67MHz$ at $-15dBm$		-59		dBc
	2500MHz: $f_{RF} = 2406.67MHz$ at $-15dBm$		-60		dBc

Note 1: Absolute Maximum Ratings are those values beyond which the life of a device may be impaired.

Note 2: The performance is measured with the test circuit shown in Figure 1. For 900MHz measurements, $C1 = 3.9pF$. For all other measurements, $C1$ is not used.

Note 3: Specifications over the $-40^{\circ}C$ to $85^{\circ}C$ temperature range are assured by design, characterization and correlation with statistical process controls.

Note 4: Operation over a wider frequency range is possible with reduced performance. Consult the factory for information and assistance.

Note 5: Turn-on and turn-off times correspond to a change in the output level of 40dB.

Note 6: The part is operable below 3.6V with reduced performance.

TYPICAL AC PERFORMANCE CHARACTERISTICS $V_{CC} = 5V$, $EN = 3V$, $T_A = 25^\circ C$, $f_{RF} = 1900MHz$, $P_{RF} = -15dBm$ (-15dBm/tone for 2-tone IIP3 tests, $\Delta f = 1MHz$), $f_{LO} = f_{RF} - 140MHz$, $P_{LO} = -5dBm$, IF output measured at 140MHz, unless otherwise noted. Test circuit shown in Figure 1.

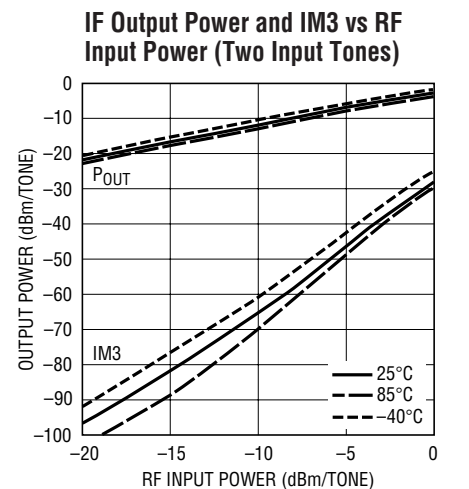
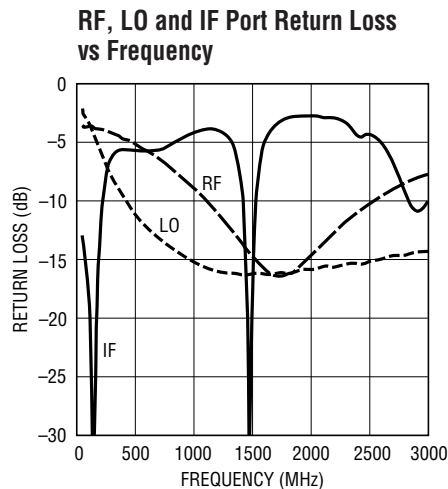
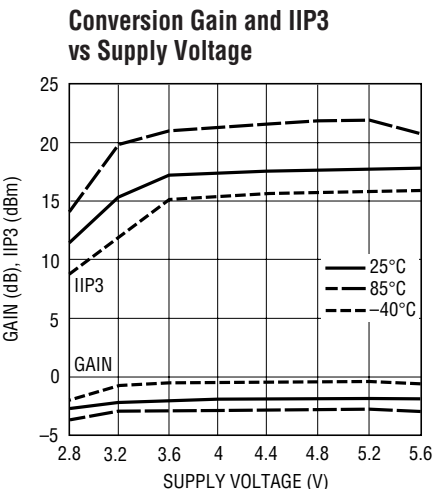
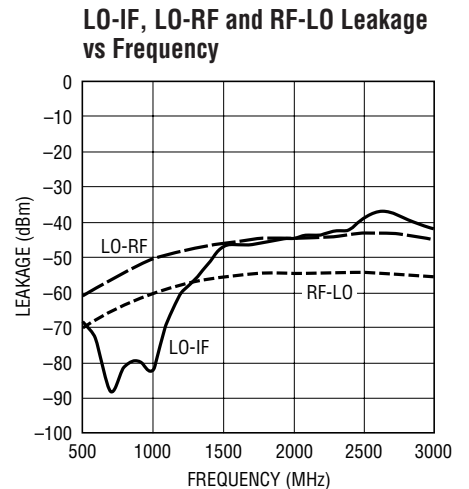
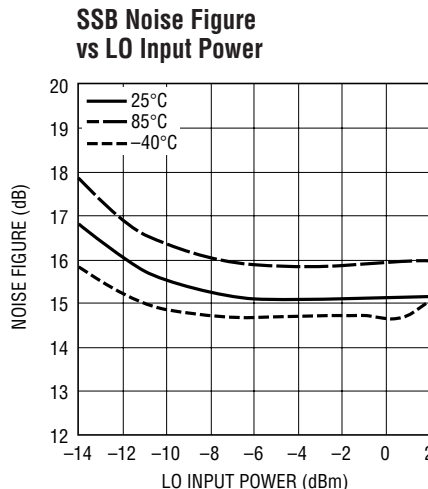
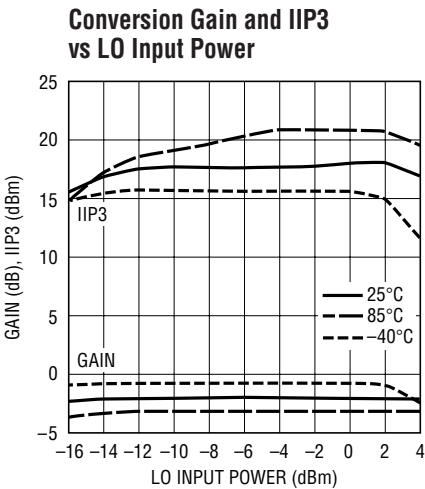
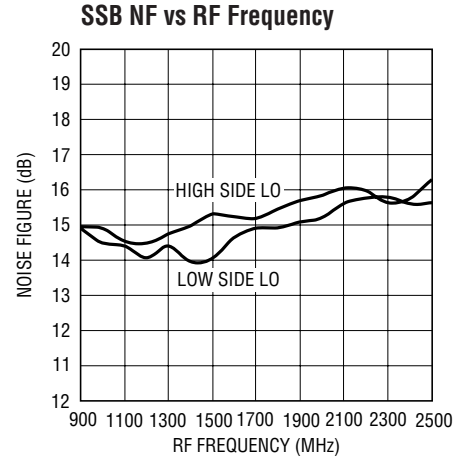
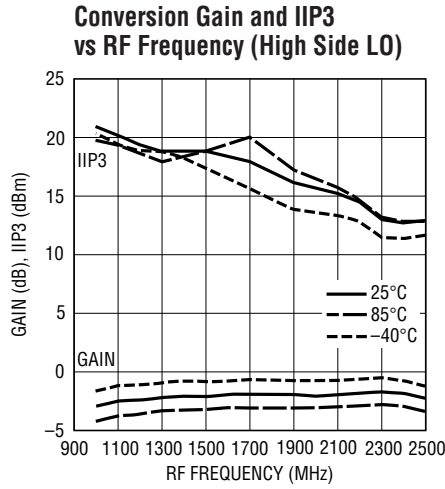
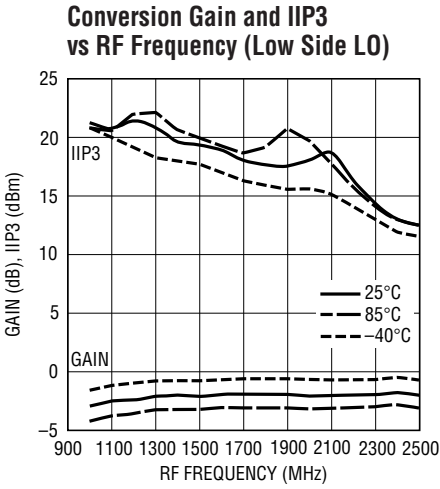

TYPICAL AC PERFORMANCE CHARACTERISTICS $V_{CC} = 5V$, $EN = 3V$, $T_A = 25^\circ C$, $f_{RF} = 1900MHz$, $P_{RF} = -15dBm$ (-15dBm/tone for 2-tone IIP3 tests, $\Delta f = 1MHz$), $f_{LO} = f_{RF} - 140MHz$, $P_{LO} = -5dBm$, IF output measured at 140MHz, unless otherwise noted. Test circuit shown in Figure 1.

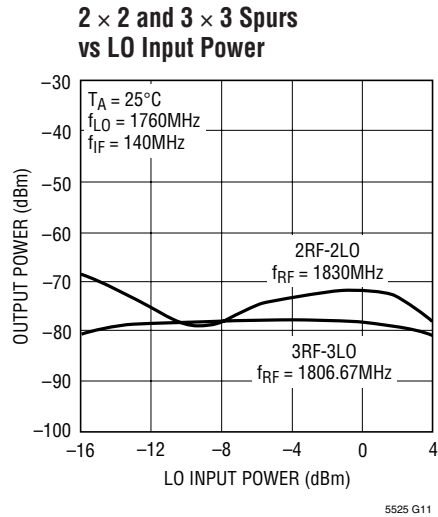
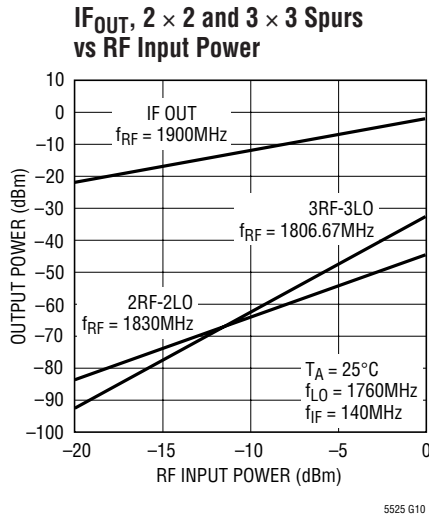

TYPICAL DC PERFORMANCE CHARACTERISTICS Test circuit shown in Figure 1.

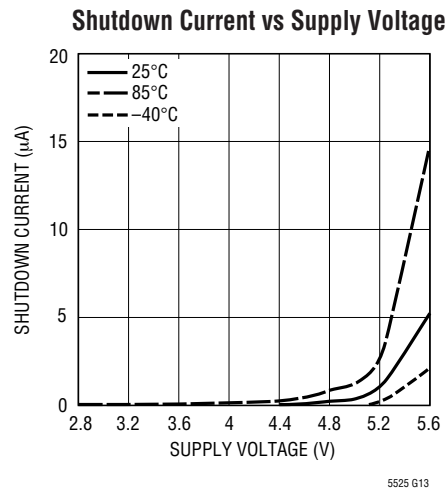
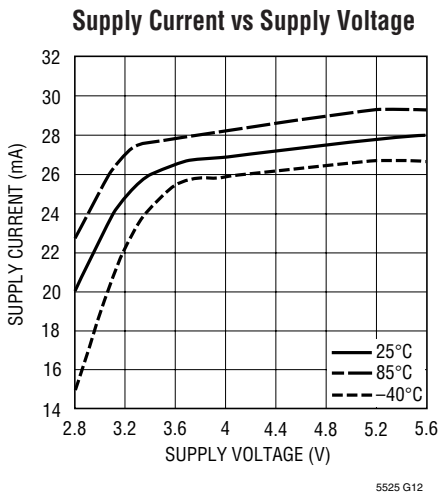

PIN FUNCTIONS

NC (Pins 1, 4, 8, 13, 16): Not Connected Internally. These pins should be grounded on the circuit board for improved LO-to-RF and LO-to-IF isolation.

RF⁺, RF⁻ (Pins 2, 3): Differential Inputs for the RF Signal. One RF input pin may be DC connected to a low impedance ground to realize a 50Ω single-ended input at the other RF pin. No external matching components are required. A DC voltage should not be applied across these pins, as they are internally connected through a transformer winding.

EN (Pin 5): Enable Pin. When the input voltage is higher than 3V, the mixer circuits supplied through Pins 6, 7, 10 and 11 are enabled. When the input voltage is less than 0.3V, all circuits are disabled. Typical enable pin input current is 55μA for EN = 5V and 0.1μA when EN = 0V.

V_{CC1} (Pin 6): Power Supply Pin for the LO Buffer Circuits. Typical current consumption is 11mA. This pin should be externally connected to the other V_{CC} pins and decoupled with 1μF and 0.01μF capacitors.

V_{CC2} (Pin 7): Power Supply Pin for the Bias Circuits. Typical current consumption is 2.5mA. This pin should be externally connected to the other V_{CC} pins and decoupled with 1μF and 0.01μF capacitors.

GND (Pins 9, 12): Ground. These pins are internally connected to the Exposed Pad for better isolation. They should be connected to ground on the circuit board, though they are not intended to replace the primary grounding through the Exposed Pad of the package.

IF⁻ and IF⁺ (Pins 10, 11): Differential Outputs for the IF Signal. An impedance transformation may be required to match the outputs. These pins must be connected to V_{CC} through impedance matching inductors, RF chokes or a transformer center-tap.

LO⁻, LO⁺ (Pins 14, 15): Differential Inputs for the Local Oscillator Signal. The LO input is internally matched to 50Ω. The LO can be driven with a single-ended source through either LO input pin, with the other LO input pin connected to ground. There is an internal DC resistance across these pins of approximately 480Ω. Thus, a DC blocking capacitor should be used if the signal source has a DC voltage present.

Exposed Pad (Pin 17): Circuit Ground Return for the Entire IC. This must be soldered to the printed circuit board ground plane.

BLOCK DIAGRAM

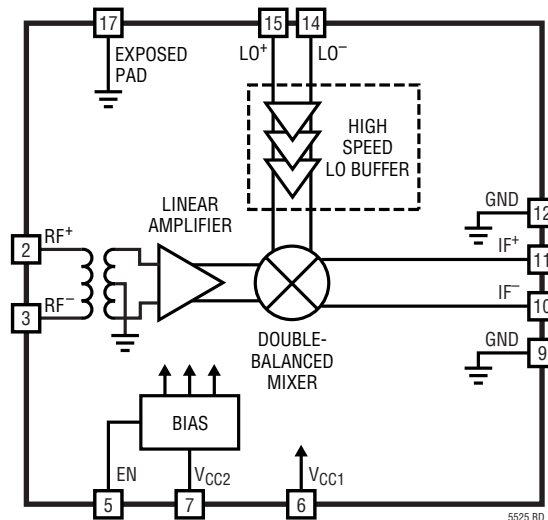

TEST CIRCUITS

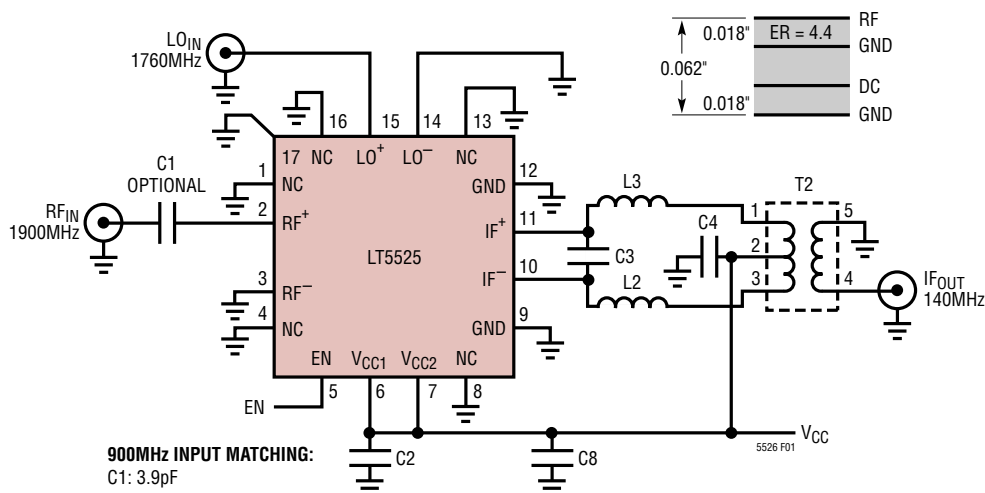

REF DES	VALUE	SIZE	PART NUMBER
C1	—	0402	Frequency Dependent
C2	0.01 μ F	0402	AVX 04023C103JAT
C3	1.2pF	0402	AVX 04025A1R2BAT
C4	100pF	0402	AVX 04025A101JAT
C8	1 μ F	0603	Taiyo Yuden LMK107BJ105MA
L2, L3	150nH	1608	Toko LL1608-FSR15J
T2	4:1	SM-22	M/A-COM ETC4-1-2

Figure 1. Test Schematic

APPLICATIONS INFORMATION

The LT5525 consists of a double-balanced mixer, RF balun, RF buffer amplifier, high speed limiting LO buffer and bias/enable circuits. The IC has been optimized for downconverter applications with RF input signals from 0.8GHz to 2.5GHz and LO signals from 500MHz to 3GHz. With proper matching, the IF output can be operated at frequencies from 0.1MHz to 1GHz. Operation over a wider frequency range is possible, though with reduced performance.

The RF, LO and IF ports are all differential, though the RF and LO ports are internally matched to 50 Ω for single-ended drive. The LT5525 is characterized and production tested using single-ended RF and LO inputs. Low side or high side LO injection can be used.

RF Input Port

The mixer's RF input, shown in Figure 2, consists of an integrated balun and a high linearity differential amplifier. The primary terminals of the balun are connected to the RF⁺ and RF⁻ pins (Pins 2 and 3, respectively). The secondary side of the balun is internally connected to the amplifier's differential inputs.

For single-ended operation, the RF⁺ pin is grounded and the RF⁻ pin becomes the RF input. It is also possible to ground the RF⁻ pin and drive the RF⁺ pin, if desired. If the RF source has a DC voltage present, then a coupling capacitor must be used in series with the RF input pin. Otherwise, excessive DC current could damage the primary winding of the balun.

APPLICATIONS INFORMATION

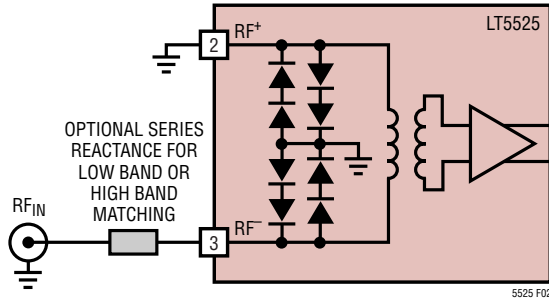

Figure 2. RF Input Schematic

As shown in Figure 3, the RF input return loss with no external matching is greater than 12dB from 1.3GHz to 2.3GHz. The RF input match can be shifted down to 800MHz by adding a series 3.9pF capacitor at the RF input. A series 1.2nH inductor can be added to shift the match up to 2.5GHz. Measured return losses with these external components are also shown in Figure 3.

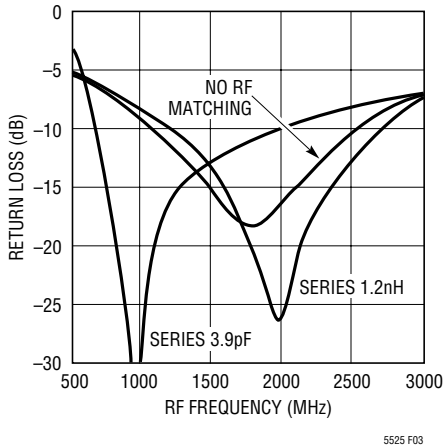

Figure 3. RF Input Return Loss Without and with External Matching Components

Figure 4 illustrates the typical conversion gain, IIP3 and NF performance of the LT5525 when the RF input match is shifted lower in frequency using an external series 3.9pF capacitor on the RF input.

RF input impedance and reflection coefficient (S11) versus frequency are shown in Table 1. The listed data is referenced to the RF⁻ pin with the RF⁺ pin grounded (no external matching). This information can be used to simulate board-level interfacing to an input filter, or to design a broadband input matching network.

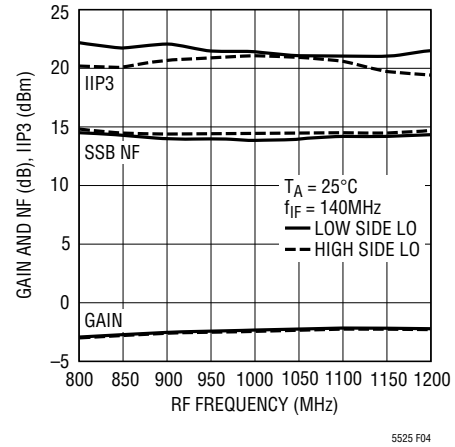

Figure 4. Typical Gain, IIP3 and NF with Series 3.9pF Matching Capacitor

Table 1. RF Port Input Impedance vs Frequency

FREQUENCY (MHz)	INPUT IMPEDANCE	REFLECTION COEFFICIENT	
		MAG	ANGLE
50	10.4 + j2.63	0.675	174
500	18.1 + j23.7	0.551	124
700	25.8 + j30.7	0.478	106
900	36.5 + j34.5	0.398	90
1100	48.4 + j33.3	0.321	74
1300	59.5 + j25.7	0.244	57
1500	65.9 + j13.1	0.177	33
1700	65.0 - j1.0	0.131	-3
1900	59.0 - j12.2	0.138	-47
2100	50.2 - j19.0	0.187	-79
2300	41.8 - j22.1	0.250	-97
2500	34.9 - j22.7	0.311	-109
2700	29.1 - j21.9	0.369	-118
3000	23.2 - j19.1	0.435	-130

A broadband RF input match can be easily realized by using both the series capacitor and series inductor as shown in Figure 5. This network provides good return loss at both lower and higher frequencies simultaneously, while maintaining good mid-band return loss. The broadband return loss is plotted in Figure 6. The return loss is better than 12dB from 700MHz to 2.6GHz using the element values of Figure 5.

LO Input Port

The LO buffer amplifier consists of high speed limiting differential amplifiers designed to drive the mixer core for high linearity. The LO⁺ and LO⁻ pins are designed for

APPLICATIONS INFORMATION

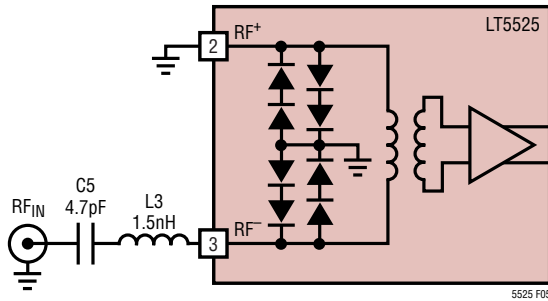

Figure 5. Wideband RF Input Matching

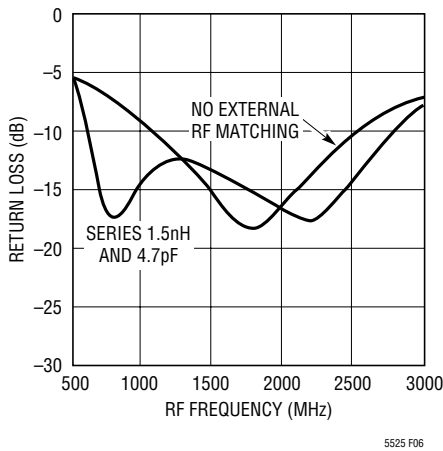

Figure 6. RF Input Return Loss Using Wideband Matching Network

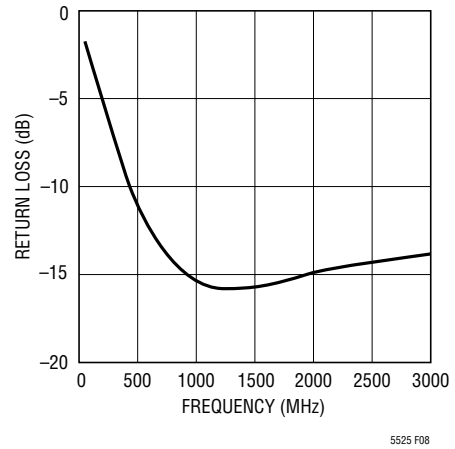

Figure 8. LO Input Return Loss

The LO port input impedance and reflection coefficient (S11) versus frequency are shown in Table 2. The listed data is referenced to the LO⁺ pin with the LO⁻ pin grounded.

Table 2. Single-Ended LO Input Impedance

FREQUENCY (MHz)	INPUT IMPEDANCE	REFLECTION COEFFICIENT	
		MAG	ANGLE
100	93.1 - j121	0.686	-30
250	55.8 - j54	0.457	-57
500	47.7 - j28	0.276	-79
1000	42.3 - j14	0.171	-110
1500	38.5 - j9.3	0.166	-135
2000	35.8 - j7.8	0.187	-146
2500	34.8 - j7.8	0.281	-148
3000	34.2 - j8.7	0.214	-149

single-ended drive, though differential drive can be used if desired. The LO input is internally matched to 50Ω. A simplified schematic for the LO input is shown in Figure 7. Measured return loss is shown in Figure 8.

If the LO source has a DC voltage present, then a coupling capacitor should be used in series with the LO input pin due to the internal resistive match.

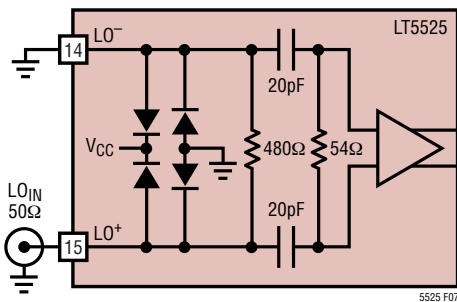

Figure 7. LO Input Schematic

IF Output Port

A simplified schematic of the IF output circuit is shown in Figure 9. The output pins, IF⁺ and IF⁻, are internally connected to the collectors of the mixer switching transistors. Both pins must be biased at the supply voltage, which can be applied through the center-tap of a transformer or

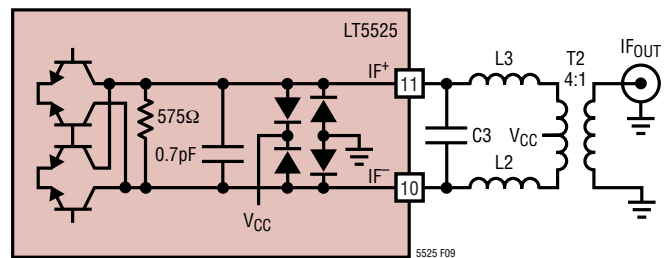

Figure 9. IF Output with External Matching

APPLICATIONS INFORMATION

through impedance-matching inductors. Each IF pin draws about 7.5mA of supply current (15mA total). For optimum single-ended performance, these differential outputs must be combined externally through an IF transformer or balun.

An equivalent small-signal model for the output is shown in Figure 10. The output impedance can be modeled as a 574Ω resistor (R_{IF}) in parallel with a 0.7pF capacitor. For most applications, the bond-wire inductance (0.7nH per side) can be ignored.

The external components, C3, L2 and L3 form an impedance transformation network to match the mixer output impedance to the input impedance of transformer T2. The values for these components can be estimated using the equations below, along with the impedance values listed in Table 3. As an example, at an IF frequency of 140MHz and $R_L = 200\Omega$ (using a 4:1 transformer for T2 with an external 50Ω load),

$$n = R_{IF}/R_L = 574/200 = 2.87$$

$$Q = \sqrt{(n - 1)} = 1.368$$

$$X_C = R_{IF}/Q = 420\Omega$$

$$C = 1/(\omega \cdot X_C) = 2.71\text{pF}$$

$$C3 = C - C_{IF} = 2.01\text{pF}$$

$$X_L = R_L \cdot Q = 274\Omega$$

$$L2 = L3 = X_L/2\omega = 156\text{nH}$$

Table 3. IF Differential Impedance (Parallel Equivalent)

FREQUENCY (MHz)	OUTPUT IMPEDANCE	REFLECTION COEFFICIENT	
		MAG	ANGLE
70	575 -j3.39k	0.840	-1.8
140	574 -j1.67k	0.840	-3.5
240	572 -j977	0.840	-5.9
450	561 -j519	0.838	-11.1
750	537 -j309	0.834	-18.6
860	525 -j267	0.831	-21.3
1000	509 -j229	0.829	-24.8
1250	474 -j181	0.822	-31.3
1500	435 -j147	0.814	-38.0

Low Cost Output Match

For low cost applications in which the required fractional bandwidth of the IF output is less than 25%, it may be possible to replace the output transformer with a lumped-

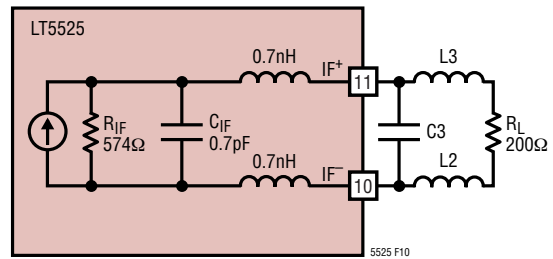

Figure 10. IF Output Small Signal Model

element network. This circuit is shown in Figure 11, where L11, L12, C11 and C12 form a narrowband bridge balun. These element values are selected to realize a 180° phase shift at the desired IF frequency, and can be estimated using the equations below. In this case, the load resistance, R_L , is 50Ω.

$$L11 = L12 = \frac{\sqrt{R_{IF} \cdot R_L}}{\omega}$$

$$C11 = C12 = \frac{1}{\omega \sqrt{R_{IF} \cdot R_L}}$$

Inductor L13 or L14 provides a DC path between V_{CC} and the IF+ pin. Only one of these inductors is required. Low cost multilayer chip inductors are adequate for L11, L12 and L13. If L14 is used instead of L13, a larger value is usually required, which may require the use of a wire-wound inductor. Capacitor C13 is a DC block which can also be used to adjust the impedance match. Capacitor C14 is a bypass capacitor.

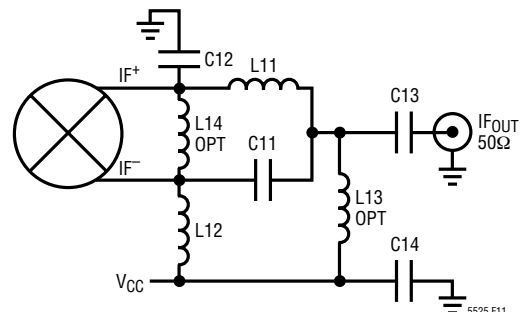

Figure 11. Narrowband Bridge IF Balun

Actual component values for IF frequencies of 240MHz, 360MHz and 450MHz are listed in Table 4. Typical IF port return loss for these examples is shown in Figure 12.

APPLICATIONS INFORMATION

Conversion gain and IIP3 performance with an RF frequency of 1900MHz are plotted vs IF frequency in Figure 13. These results show that the usable IF bandwidth for the lumped element balun is greater than 60MHz, assuming tight tolerance matching components. Contact the factory for applications assistance with this circuit.

Table 4. Component Values for Lumped Balun

IF FREQ (MHz)	L11, L12 (nH)	C11, C12 (pF)	C13 (pF)	L14 (nH)
240	100	3.9	100	560
360	68	2.7	10	270
450	56	2.2	8.2	180

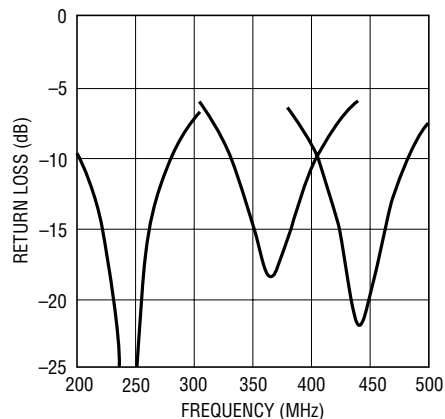

Figure 12. Typical IF Return Loss Performance with 240MHz, 360MHz and 450MHz Lumped Element Baluns

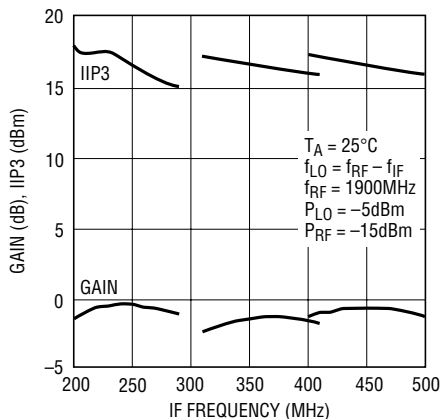

Figure 13. Typical Gain and IIP3 vs IF Frequency with 240MHz, 360MHz and 450MHz Lumped Element Baluns

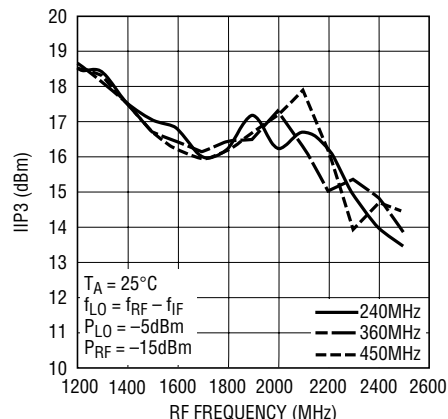
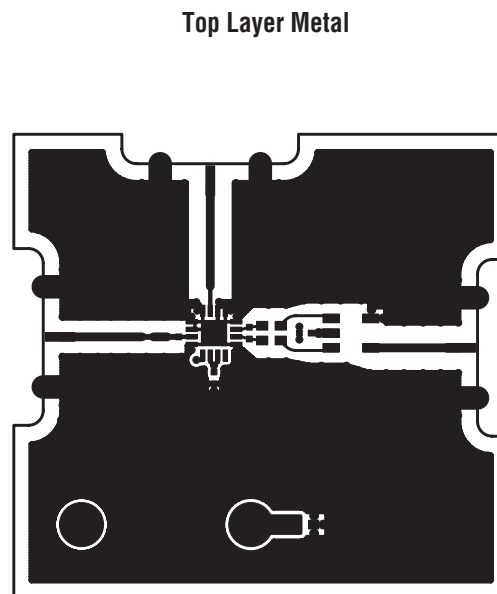
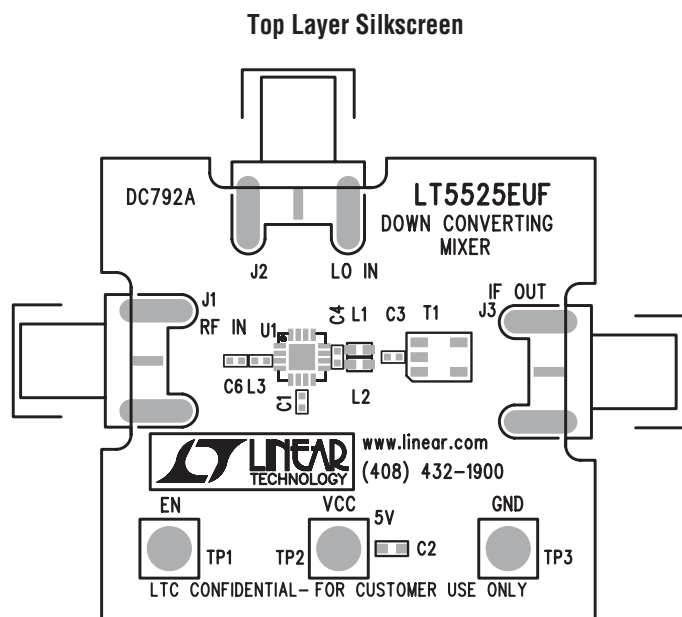

Figure 14. Typical IIP3 vs RF Frequency with Lumped Element Baluns and IF Frequencies of 240MHz, 360MHz and 450MHz

TYPICAL APPLICATIONS

Evaluation Board Layouts



PACKAGE DESCRIPTION

UF Package 16-Lead Plastic QFN (4mm × 4mm) (Reference LTC DWG # 05-08-1692)

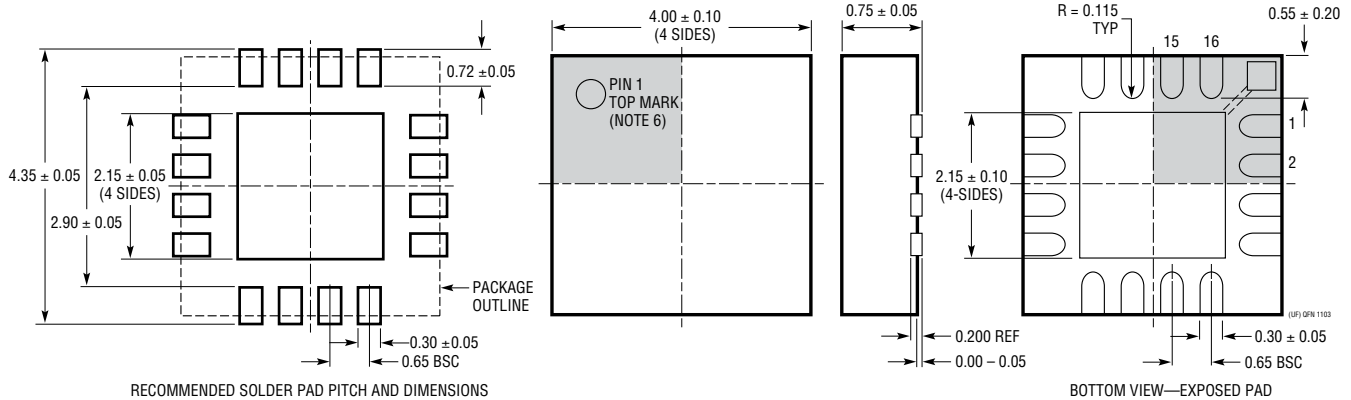

RECOMMENDED SOLDER PAD PITCH AND DIMENSIONS

- NOTE:
1. DRAWING CONFORMS TO JEDEC PACKAGE OUTLINE MO-220 VARIATION (WGCG)
 2. DRAWING NOT TO SCALE
 3. ALL DIMENSIONS ARE IN MILLIMETERS
 4. DIMENSIONS OF EXPOSED PAD ON BOTTOM OF PACKAGE DO NOT INCLUDE MOLD FLASH. MOLD FLASH, IF PRESENT, SHALL NOT EXCEED 0.15mm ON ANY SIDE

5. EXPOSED PAD SHALL BE SOLDER PLATED
6. SHADED AREA IS ONLY A REFERENCE FOR PIN 1 LOCATION ON THE TOP AND BOTTOM OF PACKAGE

RELATED PARTS

PART NUMBER	DESCRIPTION	COMMENTS
Infrastructure		
LT5512	DC-3GHz High Signal Level Down Converting Mixer	21dBm IIP3, Integrated LO Buffer
LT5514	Ultralow Distortion, IF Amplifier/ADC Driver with Digitally Controlled Gain	850MHz Bandwidth, 47dBm OIP3 at 100MHz, 10.5dB to 33dB Gain Control Range
LT5519	0.7GHz to 1.4GHz High Linearity Upconverting Mixer	17.1dBm IIP3 at 1GHz, Integrated RF Output Transformer with 50Ω Matching, Single-Ended LO and RF Ports Operation
LT5520	1.3GHz to 2.3GHz High Linearity Upconverting Mixer	15.9dBm IIP3 at 1.9GHz, Integrated RF Output Transformer with 50Ω Matching, Single-Ended LO and RF Ports Operation
LT5521	3.7GHz Very High Linearity Mixer	24.2dBm IIP3 at 1.95GHz, 12.5dB SSBNF, -42dBm LO Leakage, Supply Voltage = 3.15V to 5.25V
LT5522	600MHz to 2.7GHz High Signal Level Downconverting Mixer	4.5V to 5.25V Supply, 25dBm IIP3 at 900MHz, NF = 12.5dB, 50Ω Single-Ended RF and LO Ports
LT5526	High Linearity, Low Power Downconverting Mixer	16.5dBm IIP3 at 900MHz, NF = 11dB, Supply Current = 28mA, 3.6V to 5.3V Supply
RF Power Detectors		
LTC5508	300MHz to 7GHz RF Power Detector	44dB Dynamic Range, Temperature Compensated, SC70 Package
LTC5532	300MHz to 7GHz Precision RF Power Detector	Precision V_{OUT} Offset Control, Adjustable Gain and Offset
LT5534	50MHz to 3GHz RF Power Detector with 60dB Dynamic Range	±1dB Output Variation over Temperature, 38ns Response Time
LTC5535	600MHz to 7GHz RF Power Detector	12MHz Baseband BW, Precision Offset with Adjustable Gain and Offset
Wide Bandwidth ADCs		
LTC1749	12-Bit, 80Msps ADC	500MHz BW S/H, 71.8dB SNR, 87dB SFDR
LTC1750	14-Bit, 80Msps ADC	500MHz BW S/H, 75.5dB SNR, 90dB SFDR, 2.25V _{p-p} or 1.35V _{p-p} Input Ranges
LTC2222/ LTC2223	12-Bit, 105Msps/80Msps ADC	Low Power 775MHz BW S/H, 61dB SNR, 75dB SFDR ±0.5V or ±1V Input
LTC2224/ LTC2234	10-Bit/12-Bit, 135Msps ADC	Low Power 775MHz BW S/H, 61dB SNR, 75dB SFDR ±0.5V or ±1V Input

Looking for pricing, stock, or lifecycle information?

Click below to explore more details on WIN SOURCE:

 [View LT5525EUF#PBF on WIN SOURCE](#)

 [Linear Technology](#) Information

Optimize Your Supply Chain with WIN SOURCE Solutions

-  Global Sourcing Solution
-  Obsolete Management
-  Cost Control Management
-  Shortage Management
-  Alternative Solution
-  Excess Inventory Management