



THE DATASHEET OF
AL1696-30AS7-13



Description

The AL1696 is a highly integrated high power factor constant current converter for mains dimmable LED driver applications. The AL1696 controls the system operating in boundary conduction mode (BCM) to ease in EMI/EMC qualification and testing to meet the latest regulatory standards.

The AL1696 with build-in MOSFET solution reduces the bill of material (BOM) cost by eliminating the need of auxiliary winding and external high voltage MOSFET.

The AL1696 can be compatible with a wide range of dimmers including leading edge and trailing edge dimmers. Some dimmers can achieve deep dimming down to 1%. The AL1696 dimming curve is compliant with the standard of NEMA SSL6.

The AL1696 is available in SO-7 package, which provides an extra pin spacing between the high voltage MOSFET's drain and low voltage pins to increase electricity isolation.

Features

- Internal MOSFET up to 300V/3A, 400V/3A, 500V/2A, 600V/2A
- Tight Current Sense Tolerance: $\pm 3\%$
- Low Startup Current: 150 μ A
- Low Operation Current: 120 μ A (Switching Frequency at 5kHz)
- Single Winding Inductor
- Wide Range of Dimmer Compatibility
- Dimming Curve Compliant with NEMA SSL6
- Internal Protections
 - Under Voltage Lockout (UVLO)
 - Leading-Edge Blanking (LEB)
 - Cycle-by-cycle Over Current Protection (OCP)
 - Output Short Protection (OSP)
 - Over-Temperature Protection (OTP)
- SO-7 Package
- **Totally Lead-Free & Fully RoHS Compliant (Notes 1 & 2)**
- **Halogen and Antimony Free. "Green" Device (Note 3)**

Notes:

1. No purposely added lead. Fully EU Directive 2002/95/EC (RoHS) & 2011/65/EU (RoHS 2) compliant.
2. See http://www.diodes.com/quality/lead_free.html for more information about Diodes Incorporated's definitions of Halogen- and Antimony-free, "Green" and Lead-free.
3. Halogen- and Antimony-free "Green" products are defined as those which contain <900ppm bromine, <900ppm chlorine (<1500ppm total Br + Cl) and <1000ppm antimony compounds.

Pin Assignments

(Top View)

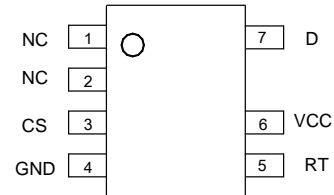

SO-7

Applications

- Mains Dimmable LED Lamps
- Offline LED Power Supply Driver

Typical Applications Circuit

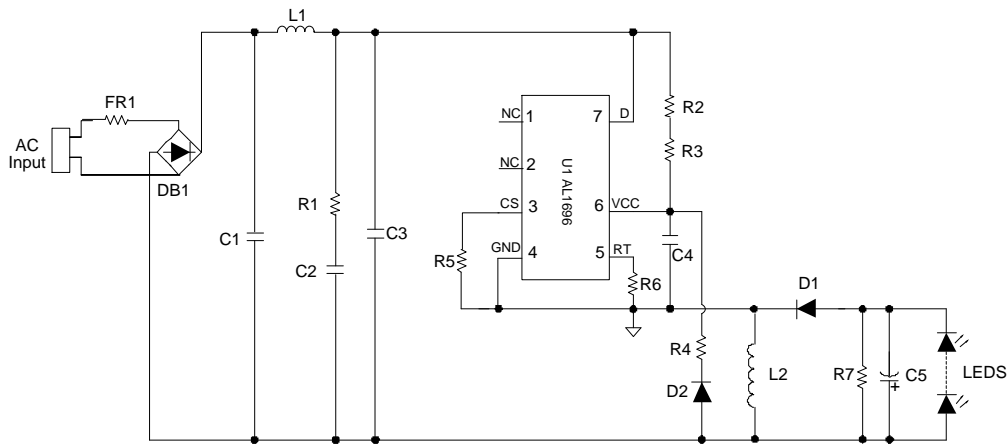

Buck-Boost Application Circuit

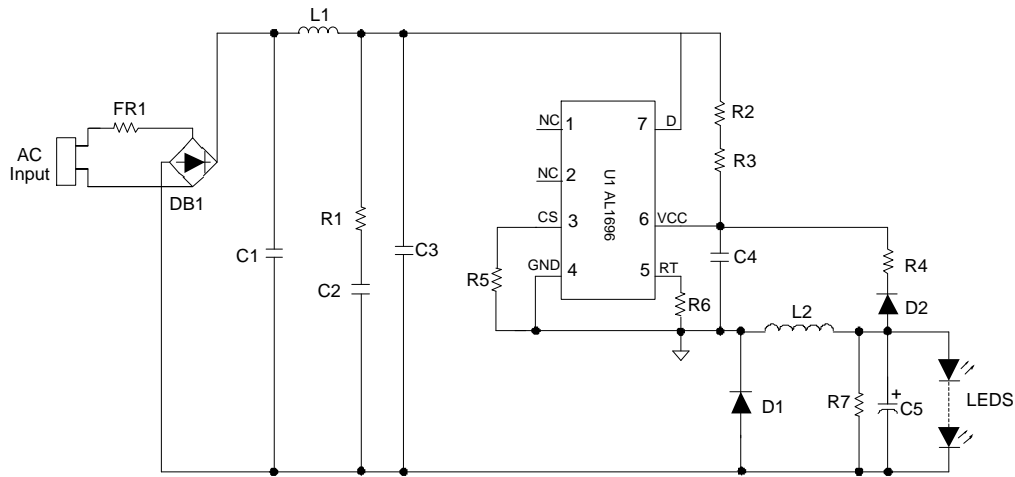

Buck Application Circuit

Pin Descriptions

Pin Number	Pin Name	Function
1, 2	NC	No connection
3	CS	Current sensing
4	GND	Ground
5	RT	Resistor set the system's maximum t_{ON}
6	VCC	Power supply voltage
7	D	Drain of the internal high voltage MOSFET

Functional Block Diagram

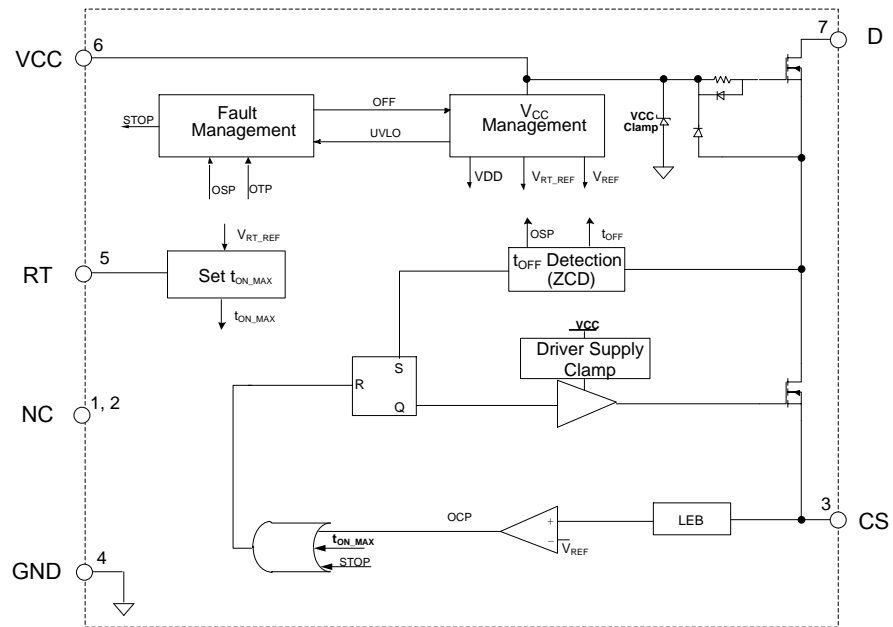

Absolute Maximum Ratings (@T_A = +25°C, unless otherwise specified.) (Note 4)

Symbol	Parameter	Rating	Unit
V _{CC}	Power Supply Voltage	18	V
V _D	Voltage on D Pin (AL1696-30AS7-13)	300	V
	Voltage on D Pin (AL1696-30BAS7-13)	400	V
	Voltage on D Pin (AL1696-20BS7-13)	500	V
	Voltage on D Pin (AL1696-20CS7-13)	600	V
I _D	Continuous Drain Current T _C = +25°C (AL1696-30AS7-13)	3.0	A
	Continuous Drain Current T _C = +25°C (AL1696-30BAS7-13)	3.0	A
	Continuous Drain Current T _C = +25°C (AL1696-20BS7-13)	2.0	A
	Continuous Drain Current T _C = +25°C (AL1696-20CS7-13)	2.0	A
V _{CS}	Voltage on CS Pin	-0.3 to 7	V
V _{RT}	Voltage on RT Pin	-0.3 to 7	V
T _J	Operating Junction Temperature	-40 to +150	°C
T _{STG}	Storage Temperature	-65 to +150	°C
T _{LEAD}	Lead Temperature (Soldering, 10 seconds)	+260	°C
P _D	Power Dissipation and Thermal Characteristics (T _A = +50°C)	0.8	W
θ _{JA}	Thermal Resistance (Junction to Ambient) (Note 5)	123	°C/W
θ _{JC}	Thermal Resistance (Junction to Case) (Note 5)	19	°C/W
-	ESD (Human Body Model)	2,000	V
	ESD (Machine Model)	200	V

- Notes:
- Stresses greater than those listed under "Absolute Maximum Ratings" may cause permanent damage to the device. These are stress ratings only, and functional operation of the device at these or any other conditions beyond those indicated under "Recommended Operating Conditions" is not implied. Exposure to "Absolute Maximum Ratings" for extended periods may affect device reliability.
 - Device mounted on 1"x1" FR-4 substrate PCB, 2oz copper, with minimum recommended pad layout.

Recommended Operating Conditions (@T_A = +25°C, unless otherwise specified.)

Symbol	Parameter	Min	Max	Unit
T _A (Note 6)	Ambient Temperature	-40	+105	°C

- Note:
- The device can operate normally at +125°C ambient temperature under the condition that the junction temperature is less than +150°C.

Electrical Characteristics (@T_A = +25°C, unless otherwise specified.)

Symbol	Parameter	Condition	Min	Typ	Max	Unit
UVLO						
V _{TH(ST)}	Startup Voltage	–	–	14.5	–	V
V _{OPR(MIN)}	Minimal Operating Voltage	After Turn On	–	8.5	–	V
V _{CC_CLAMP}	V _{CC} Clamp Voltage	I _{CC} = 1mA	–	16	–	V
Standby Current						
I _{ST}	Start-Up Current	V _{CC} = V _{TH(ST)} -0.5V, Before Start Up	–	150	–	μA
I _{CC(OPR)}	Operating Current	Switching Frequency at 5kHz	–	120	–	μA
Internal High Voltage MOSFET						
R _{DS(ON)}	Drain-Source On-State Resistance	AL1696-30A	–	–	3	Ω
		AL1696-30BA	–	–	3.4	Ω
		AL1696-20B	–	–	6	Ω
		AL1696-20C	–	–	5.5	Ω
I _{DS}	Continuous Drain-Source Current	AL1696-30A	–	–	3.0	A
		AL1696-30BA	–	–	3.0	A
		AL1696-20B	–	–	2.0	A
		AL1696-20C	–	–	2.0	A
V _{DS}	Drain-Source Breakdown Voltage	AL1696-30A	300	–	–	V
		AL1696-30BA	400	–	–	V
		AL1696-20B	500	–	–	V
		AL1696-20C	600	–	–	V
I _{DSS}	Drain-Source Leakage Current	AL1696-30A @V _{DS} = 300V, V _{GS} = 0V	–	–	1	μA
		AL1696-30BA @V _{DS} = 400V, V _{GS} = 0V	–	–	1	μA
		AL1696-20B @V _{DS} = 500V, V _{GS} = 0V	–	–	1	μA
		AL1696-20C @V _{DS} = 600V, V _{GS} = 0V	–	–	1	μA
RT						
V _{RT}	Reference Voltage of RT Pin	–	–	0.5	–	V
Current Sense						
V _{REF}	Current Sense Reference	–	0.388	0.400	0.412	V
t _{ON_MIN}	Minimum t _{ON}	–	–	550	–	ns
t _{ON_MAX}	Maximum t _{ON}	R _T = 27kΩ	–	8	–	μs
t _{OFF_MAX}	Maximum t _{OFF}	–	–	180	–	μs
t _{OFF_MIN}	Minimum t _{OFF} (Note 7)	–	–	6	–	μs
Over Temperature Protection						
–	Shutdown Temperature (Notes 7 & 8)	–	–	+170	–	°C

Notes: 7. These parameters, although guaranteed by design, are not 100% tested in production.

8. The device will latch when OTP happen and the device won't operate constantly at this temperature.

Performance Characteristics (Note 9)

Start-up Voltage vs. Ambient Temperature

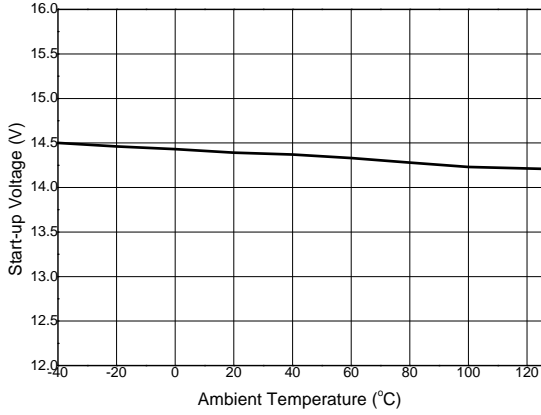

Start-up Current vs. Ambient Temperature

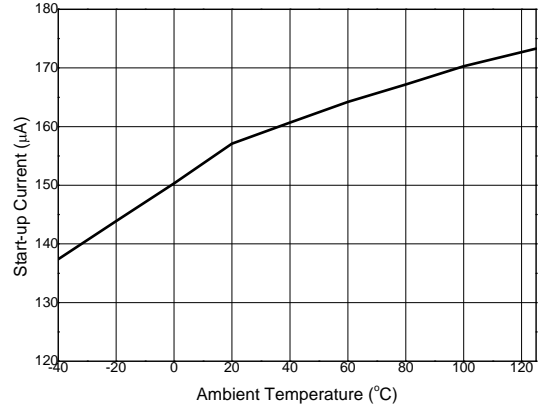

Minimal Operating Voltage vs. Ambient Temperature

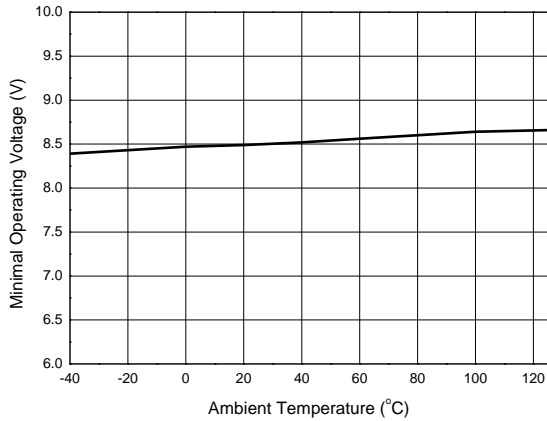

Operating Current vs. Ambient Temperature

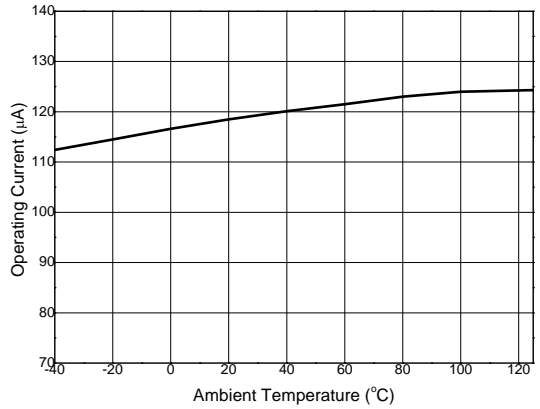

V_{CS} Reference vs. Ambient Temperature

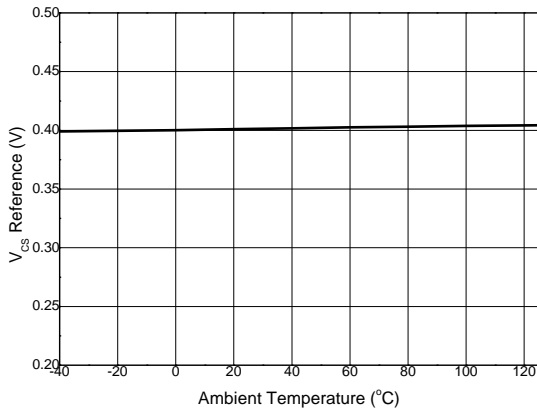

V_{RT} Reference vs. Ambient Temperature

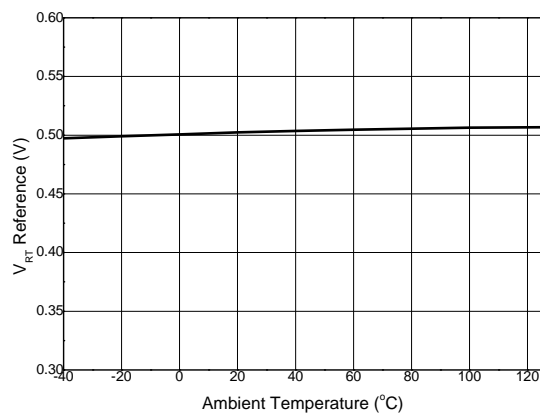

Performance Characteristics (Cont.) (Note 9)

VCC Clamp Voltage vs. Ambient Temperature

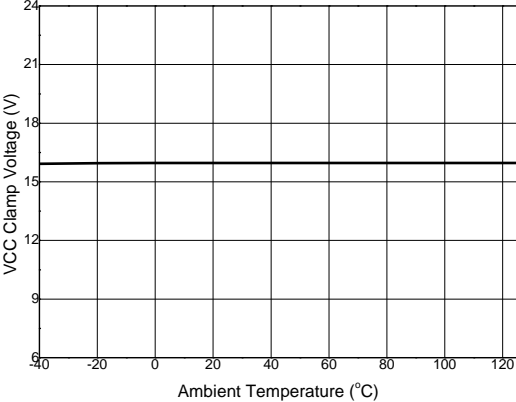

Note: 9. These electrical characteristics are tested under DC condition. The ambient temperature is equal to the junction temperature of the device.

Functional Description and Application Information

Converter Operation

The AL1696 is a single stage, single winding inductor, high efficiency, and high power factor LED driver solution for mains input phase-cutting dimmable application. It is available for four internal MOSFET options (300V/3A, 400V/3A, 500V/2A and 600V/2A) which helps to reduce the overall LED driver solution's size and optimize bom cost. The three different MOSFET options can cover most of 3~12W dimmable applications.

The AL1696 internal MOSFET's on time is limited by t_{ON_MAX} which is set through RT pin and internal 0.4V reference. The MOSFET will be turned off either its on-time triggers t_{ON_MAX} or input voltage on CS pin triggers internal 0.4V reference voltage. So if the t_{ON_MAX} is set to a very small value, the system will operate in constant on-time (t_{ON_MAX}) mode during the whole rectified mains cycle. It will result in a good power factor, but the line regulation will be worse. Normally, a recommended t_{ON_MAX} should make the system operate in constant on-time (t_{ON_MAX}) mode at valley of input voltage and peak current mode at the crest. A trade-off between PF and line regulation need to be done when setting t_{ON_MAX} .

The AL1696 adopts source-driver technology to decrease the system operating current. Besides, it uses a novel t_{OFF} time detection method without auxiliary winding. The AL1696 operates in boundary conduction mode (BCM) which can ease EMI design. All of them help AL1696 to have an extremely low bill of material (BOM).

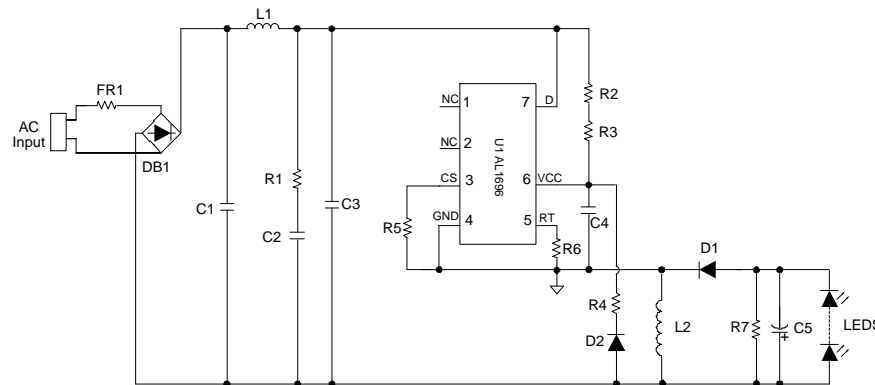

Figure 1. Typical Buck-Boost Application Circuit

Start-up and Supply Voltage

During start-up, the VCC capacitor C4 is charged through startup resistors (R2, R3) from the rectified mains input until the start-up voltage is reached, the AL1696 starts switching. In normal operation, the VCC supply is provided from two paths: one is from start-up resistors (R2, R3) and the other is from output voltage (V_{OUT}) through one diode (D2). In this way the system can provide sufficient VCC supply at low dimming angle.

The AL1696 has internal VCC clamp, the typical voltage is 16V. VCC voltage needs to be between $V_{OPR(MIN)}$ and V_{CC_CLAMP} during normal operation.

When VCC voltage drops below the under voltage lockout (UVLO), IC will stop switching. The IC will restart once the voltage on VCC pin exceeds the startup voltage ($V_{TH(ST)}$) again.

Protections

Under Voltage Lockout (UVLO)

When the voltage on the VCC pin drops below $V_{OPR(MIN)}$, the IC will stop switching. The IC will restart until the VCC voltage exceeds the startup voltage ($V_{TH(ST)}$) again.

Leading-Edge Blanking (LEB)

To prevent false detection of the peak current through MOSFET, a blanking time following switch-on is designed. When the internal switch turns on, a short current spike may appear because of the discharge of the parasitic capacitor over MOSFET's drain and source. It will be ignored during the LEB time (t_{ON_MIN}).

Cycle-by-cycle Over Current Protection (OCP)

The AL1696 has a built-in peak current detector. The R5 connected to the CS pin is used to sense the current through MOSFET and will be one of the inputs. The detection circuit is activated after the LEB time. When the voltage on CS pin reaches V_{REF} , the IC will turn off the switch to limit the output current.

Functional Description and Application Information (Cont.)

The peak current (I_{PEAK}) of the MOSFET can be set as below:

$$I_{PEAK} = \frac{V_{REF}}{R5}$$

It automatically provides a cycle-by-cycle protection of maximum current through MOSFET during operation. A propagation delay exists between over current detection and actual source-switch off, so the actual peak current will be a little higher than the OCP level set by R5.

Output-Short Protection (OSP)

When LED is shorted, the device can't detect the t_{OFF} time, and the system will work with low switching frequency of 5kHz.

Over-Temperature Protection (OTP)

The AL1696 has OTP protection function. When the junction temperature reaches +170°C typical, it will trigger an over-temperature protection which makes IC shut down and latched. Once OTP is triggered, the system will only restart after the system's power supply powers off and on again.

Design Parameters Based On Buck-Boost Topology

Setting the Current Sense Resistor R5

In AL1696 typical application, a t_{ON_MAX} is recommended to make the system operate at constant on-time (t_{ON_MAX}) mode at valley of input voltage and peak current mode at the crest. In most of cases, the t_{ON_MAX} will set to be 1.3 times of the t_{ON} at crest, and the critical angle of two operation modes will be:

$$\theta = a \sin\left(\frac{1}{1.3}\right)$$

Then the output current can be calculated as below:

$$I_{O_MEAN} = \frac{V_{REF}}{2\pi \cdot R5} \left(\int_0^{\theta} 1.3 \cdot \sin(\theta) \frac{\sqrt{2}V_{IN_RMS} \sin(\theta)}{\sqrt{2}V_{IN_RMS} \sin(\theta) + V_O} dt + \int_{\theta}^{\pi-\theta} \frac{\sqrt{2}V_{IN_RMS} \sin(\theta)}{\sqrt{2}V_{IN_RMS} \sin(\theta) + V_O} dt + \int_{\pi-\theta}^{\pi} 1.3 \cdot \sin(\theta) \frac{\sqrt{2}V_{IN_RMS} \sin(\theta)}{\sqrt{2}V_{IN_RMS} \sin(\theta) + V_O} dt \right)$$

Where,

V_{REF} is the internal reference, typical 0.4V.

R5 is the current sense resistor.

V_{IN_RMS} is the input voltage's RMS value.

V_O is the system output voltage.

Inductance Selection (L2)

The peak current of the MOSFET is calculated as below:

$$I_{PEAK} = \frac{V_{REF}}{R5}$$

The AL1696 is operating in boundary conduction mode which results in a variable operating frequency. The minimum switching frequency f_{MIN} should be set at the crest of the minimum AC input voltage. Inductance should be calculated according to the chosen f_{MIN} :

$$L2 = \frac{\sqrt{2}V_{IN_RMS} \cdot V_O}{I_{PEAK} \cdot (\sqrt{2}V_{IN_RMS} + V_O) \cdot f_{MIN}}$$

Functional Description and Application information (Cont.)

According to the Faraday's Law of Induction, the winding number of the inductance can be calculated by:

$$N_{L2} = \frac{L2 \cdot I_{PEAK}}{A_e \cdot B_m}$$

Where,

A_e is the core effective area.

B_m is the maximum magnetic flux density.

t_{ON_MAX} Setting

In order to get a high power factor and good dimmer compatibility, the system should operate in constant on time mode at valley of input voltage. It can be realized by setting the maximum on time, which is set by an external resistor connect to RT pin.

And the t_{ON} time has the below equation:

$$t_{ON_MAX} = \frac{25 \cdot C_{REF} \cdot R6}{V_{RT_REF}}$$

Where,

V_{RT_REF} is the internal RT pin 0.5V's reference.

C_{REF} is the internal 6pF capacitor.

Dimmer Compatibility

Passive Bleeder Design

The passive bleeder is designed to supply latching and holding current to get rid of dimmer's misfire and flicker.

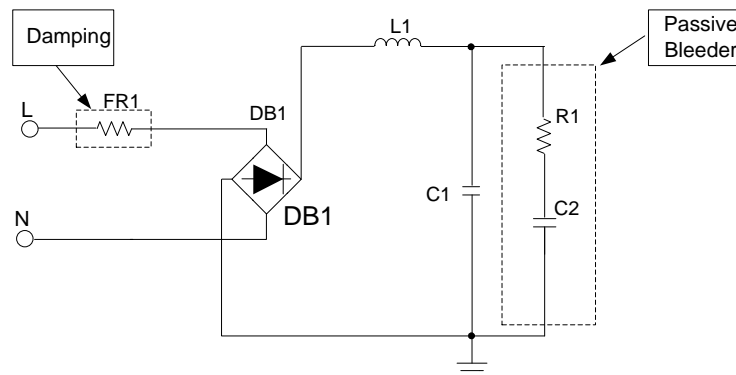

Figure 2. LED Driver Schematic with Passive Bleeder

The passive bleeder includes a capacitor (C2, in hundreds of nF) to provide latching current and a resistor (R1) to limit the current spike. Because a large C2 will affect the PF, THD and efficiency negatively, the value of the capacitor (C2) should be selected carefully. Generally, a capacitance from 100nF/400V to 330nF/400V is recommended. R1 is used to limit the latching current. If R1 is too big, the latching current will be not enough and the TRIAC dimmer will be misfired, resulting in LED flicker. If R1 is too small, it will result in greater power dissipation. Generally, a 200Ω to 2KΩ resistor is recommended for R1.

Passive Damping Design

FR1 is to limit the spike current caused by quick charging of C2 when dimmer on. Normally, FR1 will be chosen from 20Ω to 100Ω for low line like 120V_{AC} application, and 51Ω to 200Ω for high line like 230V_{AC} application.

Ordering Information

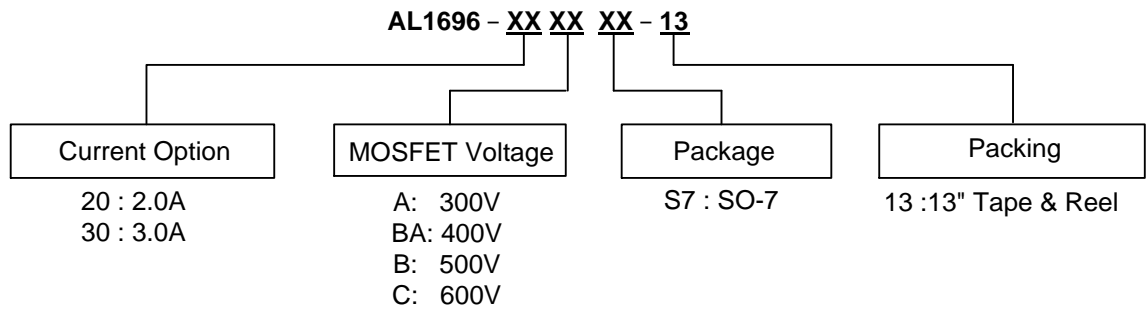

Part Number	Package Code	Package	13" Tape and Reel	
			Quantity	Part Number Suffix
AL1696-30AS7-13	S7	SO-7	4000/Tape & Reel	-13
AL1696-30BAS7-13	S7	SO-7	4000/Tape & Reel	-13
AL1696-20BS7-13	S7	SO-7	4000/Tape & Reel	-13
AL1696-20CS7-13	S7	SO-7	4000/Tape & Reel	-13

Marking Information

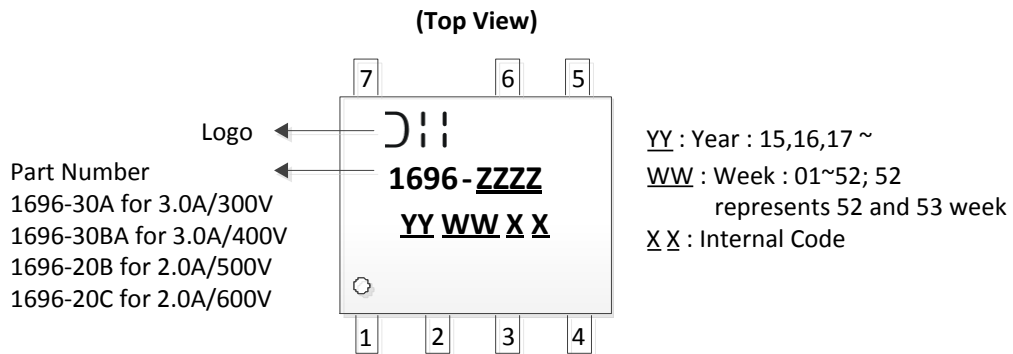

Package Outline Dimensions (All dimensions in mm.)

(1) Package Type: SO-7

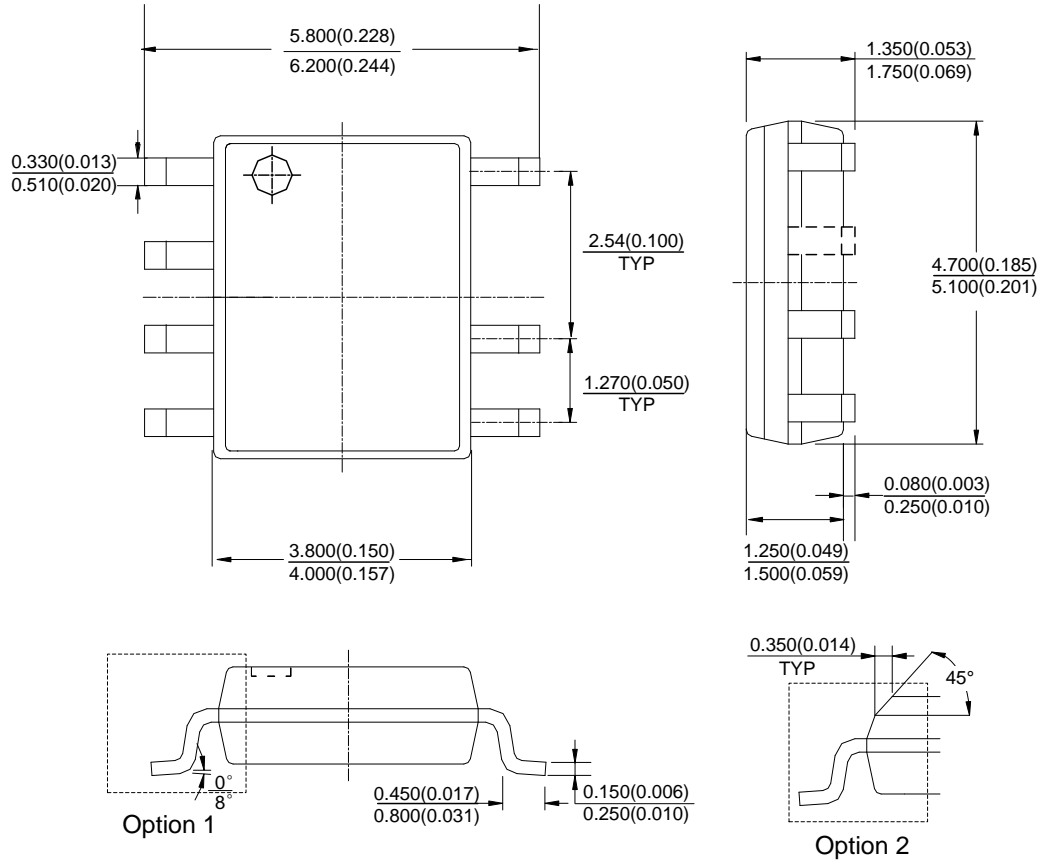

Note: Eject hole, oriented hole and mold mark is optional.

Suggested Pad Layout

(1) Package Type: SO-7

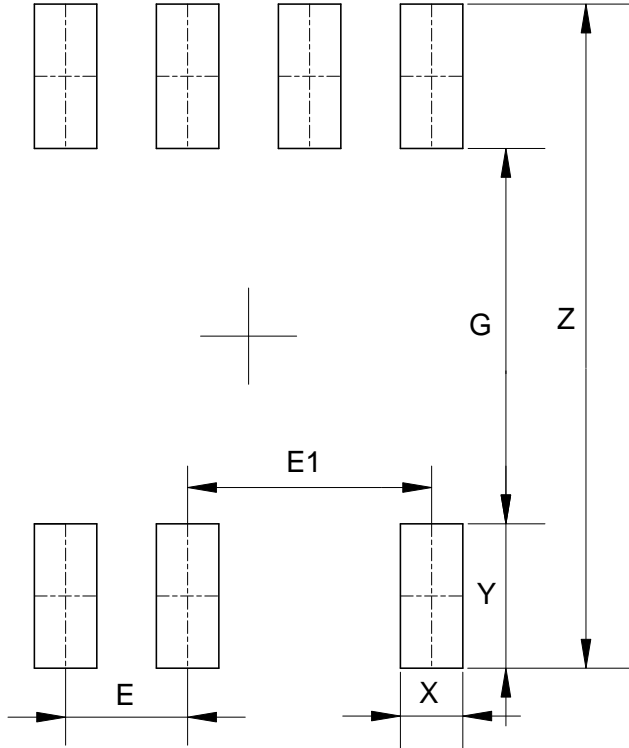

Dimensions	Z (mm)/(inch)	G (mm)/(inch)	X (mm)/(inch)	Y (mm)/(inch)	E (mm)/(inch)	E1 (mm)/(inch)
Value	6.900/0.272	3.900/0.154	0.650/0.026	1.500/0.059	1.270/0.050	2.540/0.100

IMPORTANT NOTICE

DIODES INCORPORATED MAKES NO WARRANTY OF ANY KIND, EXPRESS OR IMPLIED, WITH REGARDS TO THIS DOCUMENT, INCLUDING, BUT NOT LIMITED TO, THE IMPLIED WARRANTIES OF MERCHANTABILITY AND FITNESS FOR A PARTICULAR PURPOSE (AND THEIR EQUIVALENTS UNDER THE LAWS OF ANY JURISDICTION).

Diodes Incorporated and its subsidiaries reserve the right to make modifications, enhancements, improvements, corrections or other changes without further notice to this document and any product described herein. Diodes Incorporated does not assume any liability arising out of the application or use of this document or any product described herein; neither does Diodes Incorporated convey any license under its patent or trademark rights, nor the rights of others. Any Customer or user of this document or products described herein in such applications shall assume all risks of such use and will agree to hold Diodes Incorporated and all the companies whose products are represented on Diodes Incorporated website, harmless against all damages.

Diodes Incorporated does not warrant or accept any liability whatsoever in respect of any products purchased through unauthorized sales channel. Should Customers purchase or use Diodes Incorporated products for any unintended or unauthorized application, Customers shall indemnify and hold Diodes Incorporated and its representatives harmless against all claims, damages, expenses, and attorney fees arising out of, directly or indirectly, any claim of personal injury or death associated with such unintended or unauthorized application.

Products described herein may be covered by one or more United States, international or foreign patents pending. Product names and markings noted herein may also be covered by one or more United States, international or foreign trademarks.

This document is written in English but may be translated into multiple languages for reference. Only the English version of this document is the final and determinative format released by Diodes Incorporated.

LIFE SUPPORT

Diodes Incorporated products are specifically not authorized for use as critical components in life support devices or systems without the express written approval of the Chief Executive Officer of Diodes Incorporated. As used herein:

A. Life support devices or systems are devices or systems which:

1. are intended to implant into the body, or
2. support or sustain life and whose failure to perform when properly used in accordance with instructions for use provided in the labeling can be reasonably expected to result in significant injury to the user.

B. A critical component is any component in a life support device or system whose failure to perform can be reasonably expected to cause the failure of the life support device or to affect its safety or effectiveness.



Customers represent that they have all necessary expertise in the safety and regulatory ramifications of their life support devices or systems, and acknowledge and agree that they are solely responsible for all legal, regulatory and safety-related requirements concerning their products and any use of Diodes Incorporated products in such safety-critical, life support devices or systems, notwithstanding any devices- or systems-related information or support that may be provided by Diodes Incorporated. Further, Customers must fully indemnify Diodes Incorporated and its representatives against any damages arising out of the use of Diodes Incorporated products in such safety-critical, life support devices or systems.

Copyright © 2016, Diodes Incorporated

www.diodes.com

Looking for pricing, stock, or lifecycle information?

Click below to explore more details on WIN SOURCE:

-  [View AL1696-30AS7-13 on WIN SOURCE](#)
-  [Diodes Incorporated Information](#)

Optimize Your Supply Chain with WIN SOURCE Solutions

-  Global Sourcing Solution
-  Obsolete Management
-  Cost Control Management
-  Shortage Management
-  Alternative Solution
-  Excess Inventory Management