



**THE DATASHEET OF
MASW-008566-TR3000**



GaAs SP4T 2.5 V High Power Switch DC - 3.0 GHz

Rev. V1

Features

- Low Voltage Operation: 2.5 V
- Low Harmonics: < -65 dBc at +34 dBm & 1 GHz
- Low Insertion Loss: 0.65 dB @ 1 GHz
- High Isolation: 23 dB @ 2 GHz
- 0.5 micron GaAs PHEMT Process
- Lead-Free 4mm 16-lead PQFN Package
- 100% Matte Tin Plating over Copper
- Halogen-Free "Green" Mold Compound
- 260°C Reflow Compatible
- RoHS* Compliant Version of MASWSS0118

Description

M/A-COM's MASW-008566 is a GaAs PHEMT MMIC single pole four throw (SP4T) high power switch in a low cost 4 mm 16-lead PQFN package. The MASW-008566 is ideally suited for applications where high power, low control voltage, low insertion loss, high isolation, small size, and low cost are required.

Typical applications are for GSM and DCS handset systems that connect separate transmit and receive functions to a common antenna, as well as other handset and related applications. This part can be used in all systems operating up to 3.0 GHz requiring high power at low control voltage.

The MASW-008566 is fabricated using a 0.5 micron gate length GaAs PHEMT process. The process features full passivation for performance and reliability.

Ordering Information^{1,2}

Part Number	Package
MASW-008566-TR3000	3000 piece reel
MASW-008566-001SMB	Sample Board

1. Reference Application Note M513 for reel size information.
2. All sample boards include 5 loose parts.

Functional Schematic

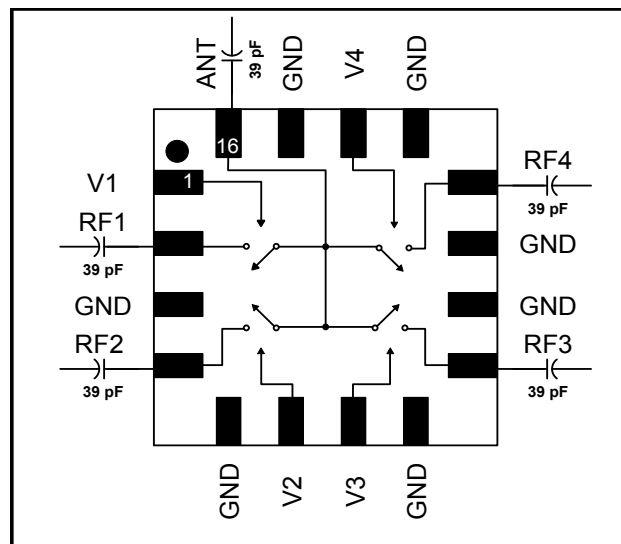

Pin Configuration

Pin No.	Pin Name	Description
1	V1	Control 1
2	RF1	RF Port 1
3	GND	RF Ground
4	RF2	RF Port 2
5	GND	RF Ground
6	V2	Control 2
7	V3	Control 3
8	GND	RF Ground
9	RF3	RF Port 3
10	GND	RF Ground
11	GND	RF Ground
12	RF4	RF Port 4
13	GND	RF Ground
14	V4	Control 4
15	GND	RF Ground
16	ANT	Antenna Port
17	Paddle ³	RF Ground

3. The exposed pad centered on the package bottom must be connected to RF and DC ground.

* Restrictions on Hazardous Substances, European Union Directive 2002/95/EC.

GaAs SP4T 2.5 V High Power Switch DC - 3.0 GHz

Rev. V1

Electrical Specifications: $T_A = 25^\circ\text{C}$, $Z_0 = 50 \Omega$ ⁴

Parameter	Test Conditions	Units	Min.	Typ.	Max.
Insertion Loss ⁵	DC – 1 GHz	dB	—	0.65	0.85
	1 – 2 GHz	dB	—	0.80	1.00
	2 - 3 GHz	dB	—	1.00	—
Isolation	DC – 1 GHz	dB	27	29.0	—
	1 – 2 GHz	dB	21	23.0	—
	2 - 3 GHz	dB	—	18.5	—
Return Loss	DC – 3 GHz	dB	—	20	—
IP3	Two Tone +26 dBm, 5 MHz Spacing, > 50 MHz $V_C = 0 \text{ V} / 2.5 \text{ V}$	dBm	—	57	—
IP2	Two Tone +26 dBm, 5 MHz Spacing, > 50 MHz $V_C = 0 \text{ V} / 2.5 \text{ V}$	dBm	—	81	—
P.1dB	$V_C = 0 \text{ V} / 2.5 \text{ V}$	dBm	—	38	—
2 nd Harmonic	1 GHz, $P_{IN} = +34 \text{ dBm}$, $V_C = 0 \text{ V} / 2.5 \text{ V}$	dBc	—	-80	-71
3 rd Harmonic	1 GHz, $P_{IN} = +34 \text{ dBm}$, $V_C = 0 \text{ V} / 2.5 \text{ V}$	dBc	—	-68	-65
Trise, Tfall	10% RF to 90% RF, 90% to 10% RF, $V_C = 0 \text{ V} / 2.5 \text{ V}$	μS	—	0.2	—
Ton, Toff	50% control to 90% RF, 50% control to 10% RF, $V_C = 0 \text{ V} / 2.5 \text{ V}$	μS	—	0.2	—
Transients		mV	—	35	—
Control Current	$V_C = 0 \text{ V} / 2.5 \text{ V}$, 34 dBm	μA	—	10	50

4. External DC blocking capacitors are required on all RF ports.

5. Insertion Loss can be optimized by varying the DC blocking capacitor value, e.g. 1000 pF for 100 - 500 MHz, 39 pF for 0.5 - 3 GHz.

Absolute Maximum Ratings^{6,7}

Parameter	Absolute Maximum
Input Power (0.5 - 3.0 GHz, 2.5 V Control)	+38 dBm
Voltage	± 8.5 volts
Operating Temperature	-40°C to $+85^\circ\text{C}$
Storage Temperature	-65°C to $+150^\circ\text{C}$

6. Exceeding any one or combination of these limits may cause permanent damage to this device.

7. M/A-COM does not recommend sustained operation near these survivability limits.

Truth Table^{8,9}

V1	V2	V3	V4	ANT-RF1	ANT-RF2	ANT-RF3	ANT-RF4
1	0	0	0	On	Off	Off	Off
0	1	0	0	Off	On	Off	Off
0	0	1	0	Off	Off	On	Off
0	0	0	1	Off	Off	Off	On

8. Differential voltage, V (state 1) -V (state 2), must be 2.5 V minimum.

9. 0 = -5 V to +2.5 V, 1 = -2.5 V to +5 V

Typical Performance Curves

Insertion Loss vs. Temperature

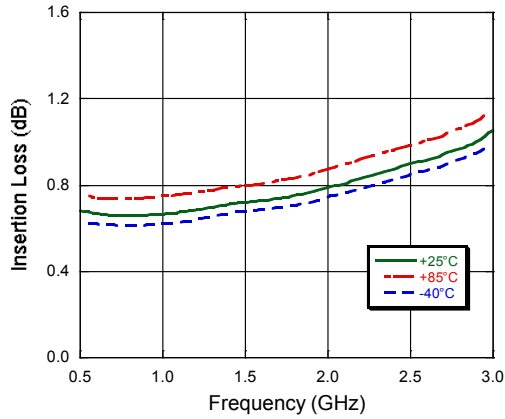

Isolation vs. Temperature

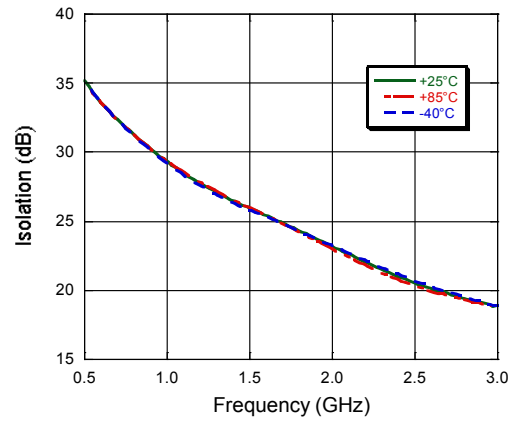

1 GHz 2nd Harmonic Rejection

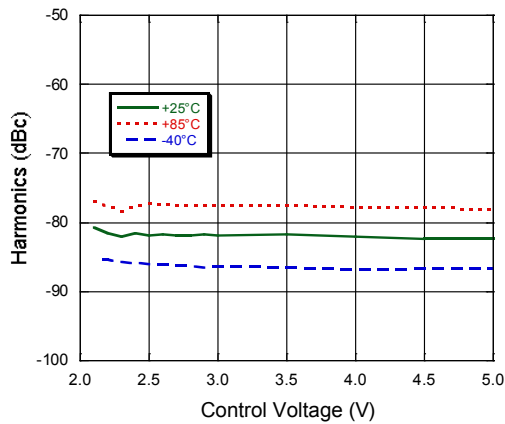

1 GHz 3rd Harmonic Rejection

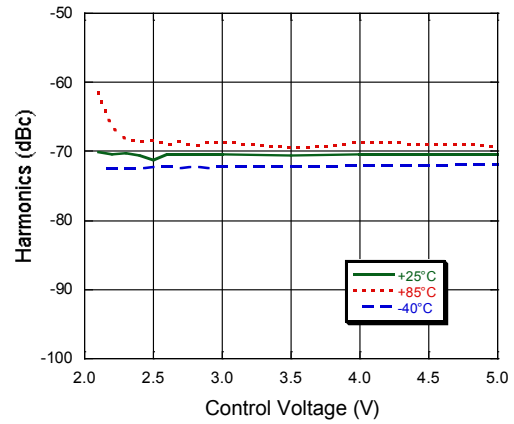

M/A-COM Technology Solutions Inc. All rights reserved.

Information in this document is provided in connection with M/A-COM Technology Solutions Inc ("MACOM") products. These materials are provided by MACOM as a service to its customers and may be used for informational purposes only. Except as provided in MACOM's Terms and Conditions of Sale for such products or in any separate agreement related to this document, MACOM assumes no liability whatsoever. MACOM assumes no responsibility for errors or omissions in these materials. MACOM may make changes to specifications and product descriptions at any time, without notice. MACOM makes no commitment to update the information and shall have no responsibility whatsoever for conflicts or incompatibilities arising from future changes to its specifications and product descriptions. No license, express or implied, by estoppel or otherwise, to any intellectual property rights is granted by this document.

THESE MATERIALS ARE PROVIDED "AS IS" WITHOUT WARRANTY OF ANY KIND, EITHER EXPRESS OR IMPLIED, RELATING TO SALE AND/OR USE OF MACOM PRODUCTS INCLUDING LIABILITY OR WARRANTIES RELATING TO FITNESS FOR A PARTICULAR PURPOSE, CONSEQUENTIAL OR INCIDENTAL DAMAGES, MERCHANTABILITY, OR INFRINGEMENT OF ANY PATENT, COPYRIGHT OR OTHER INTELLECTUAL PROPERTY RIGHT. MACOM FURTHER DOES NOT WARRANT THE ACCURACY OR COMPLETENESS OF THE INFORMATION, TEXT, GRAPHICS OR OTHER ITEMS CONTAINED WITHIN THESE MATERIALS. MACOM SHALL NOT BE LIABLE FOR ANY SPECIAL, INDIRECT, INCIDENTAL, OR CONSEQUENTIAL DAMAGES, INCLUDING WITHOUT LIMITATION, LOST REVENUES OR LOST PROFITS, WHICH MAY RESULT FROM THE USE OF THESE MATERIALS.

MACOM products are not intended for use in medical, lifesaving or life sustaining applications. MACOM customers using or selling MACOM products for use in such applications do so at their own risk and agree to fully indemnify MACOM for any damages resulting from such improper use or sale.

5

M/A-COM Technology Solutions Inc. (MACOM) and its affiliates reserve the right to make changes to the product(s) or information contained herein without notice.
Visit www.macom.com for additional data sheets and product information.

Looking for pricing, stock, or lifecycle information?

Click below to explore more details on WIN SOURCE:

- ⊖ [View MASW-008566-TR3000 on WIN SOURCE](#)
- ⊖ [M/A-Com Technology Solutions Information](#)

Optimize Your Supply Chain with WIN SOURCE Solutions

- ✓ Global Sourcing Solution
- ✓ Obsolete Management
- ✓ Cost Control Management
- ✓ Shortage Management
- ✓ Alternative Solution
- ✓ Excess Inventory Management