



**THE DATASHEET OF  
STP16CPS05TTR**



## Low voltage 16-bit constant current LED sink driver with auto power saving

Datasheet - production data

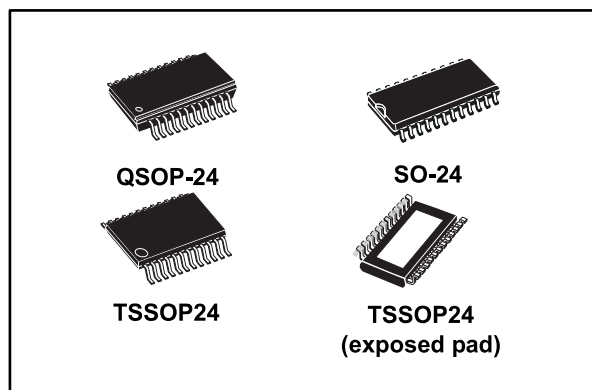

### Description

The STP16CPS05 is a monolithic, low voltage, low current power 16-bit shift register designed for LED panel displays. The STP16CPS05 contains a 16-bit serial-in, parallel-out shift register that feeds a 16-bit, D-type storage register. In the output stage, sixteen regulated current sources provide from 5 mA to 100 mA constant current to drive the LEDs. The auto power shut-down and auto power-ON feature allows the device to save power without any external intervention. The output current setup time is 40 ns (typ.), thus improving the system performance. The LEDs' brightness can be controlled by using an external resistor to adjust the STP16CPS05 output current. The STP16CPS05 guarantees a 20 V output driving capability, allowing users to connect more LEDs in series. The high clock frequency, 30 MHz, makes the device suitable for high data rate transmission. The 3.3 V voltage supply is useful in applications that interface with a 3.3 V microcontroller.

### Features

- Low voltage power supply down to 3 V
- 16 constant current output channels
- Adjustable output current through external resistor
- Serial data IN/parallel data OUT
- Auto power-saving feature minimizes the quiescent current if no active data is detected on the latches
- Can be driven by a 3.3 V microcontroller
- Output current: 5-100 mA
- Max clock frequency 30 MHz
- ESD protection: 2 kV HBM, 200 V MM

Table 1: Device summary

Order code	Package	Packing
STP16CPS05MTR	SO-24	1000 parts per reel
STP16CPS05TTR	TSSOP24	2500 parts per reel
STP16CPS05XTTR	TSSOP24 exposed pad	2500 parts per reel
STP16CPS05PTR	QSOP-24	2500 parts per reel

**Contents**

**1 Summary description..... 3**

    1.1 Pin connection and description ..... 3

**2 Electrical ratings ..... 4**

    2.1 Absolute maximum ratings ..... 4

    2.2 Thermal data ..... 4

    2.3 Recommended operating conditions ..... 5

**3 Electrical characteristics ..... 6**

**4 Equivalent circuit and outputs ..... 8**

**5 Timing diagrams..... 11**

**6 Typical characteristics ..... 14**

**7 Test circuit ..... 18**

**8 Package information ..... 20**

    8.1 QSOP-24 package information ..... 21

    8.2 SO-24 package information ..... 23

    8.3 TSSOP24 package information..... 24

    8.4 TSSOP24 exposed pad package information ..... 26

    8.5 TSSOP24, TSSOP24 exposed pad and .....  
        SO-24 packing information..... 28

**9 Revision history ..... 30**



# 1 Summary description

Table 2: Typical current accuracy

Output voltage	Current accuracy		Output current	V <sub>DD</sub>	Temperature
	Between bits	Between ICs			
≥ 1.3 V	± 1.5 %	± 5 %	20 to 100 mA	3.3 V to 5 V	25 °C

## 1.1 Pin connection and description

Figure 1: Pin connection

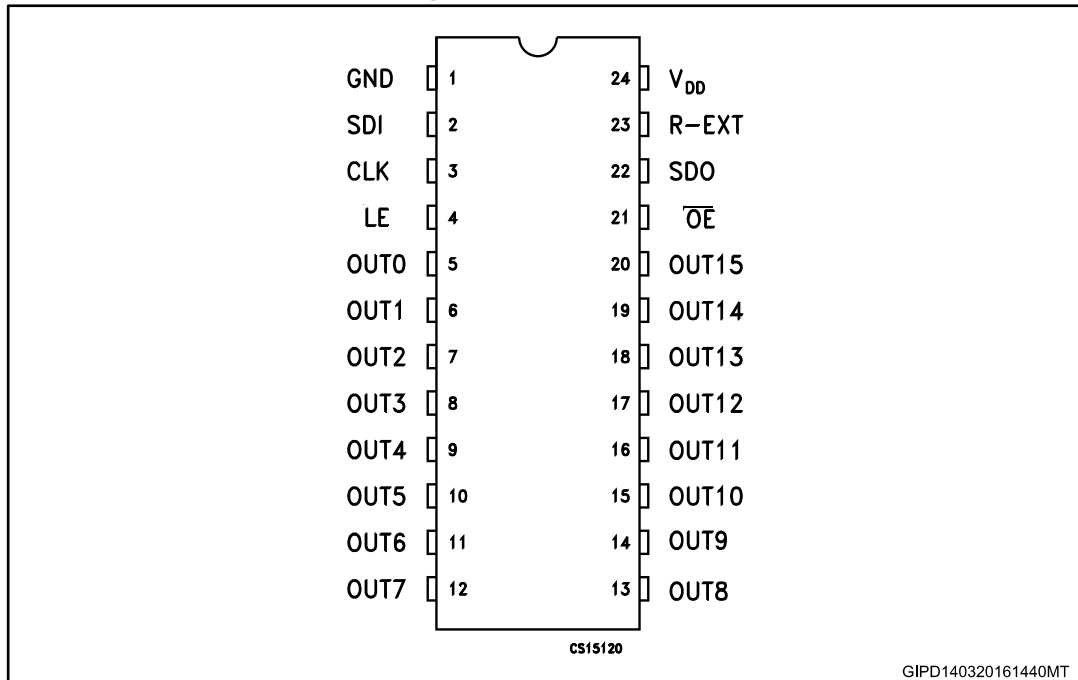

The exposed pad should be electrically connected to a metal land electrically isolated or connected to GND.

Table 3: Pin description

Pin n°	Symbol	Name and function
1	GND	Ground terminal
2	SDI	Serial data input terminal
3	CLK	Clock input terminal
4	LE	Latch input terminal
5-20	OUT 0-15	Output terminal
21	$\overline{\text{OE}}$	Input terminal of output enable (active low)
22	SDO	Serial data out terminal
23	R-EXT	Input terminal for an external resistor for constant current programming
24	V <sub>DD</sub>	Supply voltage terminal

## 2 Electrical ratings

### 2.1 Absolute maximum ratings

Stressing the device above the rating listed in the “absolute maximum ratings” table may cause permanent damage to the device. These are stress ratings only and operation of the device at these or any other conditions above those indicated in the Operating sections of this specification is not implied. Exposure to Absolute Maximum Rating conditions for extended periods may affect device reliability.

**Table 4: Absolute maximum ratings**

Symbol	Parameter	Value	Unit
V <sub>DD</sub>	Supply voltage	0 to 7	V
V <sub>O</sub>	Output voltage	-0.5 to 20	V
I <sub>O</sub>	Output current	100	mA
V <sub>I</sub>	Input voltage	-0.4 to V <sub>DD</sub>	V
I <sub>GND</sub>	GND terminal current	1600	mA
f <sub>CLK</sub>	Clock frequency	50	MHz
T <sub>J</sub>	Junction temperature range <sup>(1)</sup>	-40 to +170	°C

**Notes:**

<sup>(1)</sup> Such absolute value is achieved according the thermal shutdown.

### 2.2 Thermal data

**Table 5: Thermal data**

Symbol	Parameter	Value	Unit	
T <sub>OPR</sub>	Operating temperature range	-40 to + 125	°C	
T <sub>STG</sub>	Storage temperature range	-55 to + 150	°C	
R <sub>thJA</sub>	Thermal resistance junction-ambient <sup>(1)</sup>	SO-24	42.7	°C/W
		TSSOP24	55	°C/W
		TSSOP24 <sup>(2)</sup> exposed pad	37.5	°C/W
		QSOP-24	55	°C/W

**Notes:**

<sup>(1)</sup> According to jedec standard 51-7B.

<sup>(2)</sup> The exposed pad should be soldered directly to the PCB to realize the thermal benefits.

## 2.3 Recommended operating conditions

Table 6: Recommended operating conditions at 25 °C

Symbol	Parameter	Test conditions	Min.	Typ.	Max.	Unit
V <sub>DD</sub>	Supply voltage		3.0		5.5	V
V <sub>O</sub>	Output voltage				20	V
I <sub>O</sub>	Output current	OUTn	5		100	mA
I <sub>OH</sub>	Output current	SERIAL-OUT			+1	mA
I <sub>OL</sub>	Output current	SERIAL-OUT			-1	mA
V <sub>IH</sub>	Input voltage		0.7 V <sub>DD</sub>		V <sub>DD</sub>	V
V <sub>IL</sub>	Input voltage		-0.3		0.3 V <sub>DD</sub>	V
t <sub>wLAT</sub>	LE pulse width	V <sub>DD</sub> = 3.0 V to 5.0 V	10			ns
t <sub>wCLK</sub>	CLK pulse width		8			ns
t <sub>wEN</sub>	$\overline{\text{OE}}$ pulse width		100			ns
t <sub>SETUP(D)</sub>	Setup time for DATA		14			ns
t <sub>HOLD(D)</sub>	Hold time for DATA		5			ns
t <sub>SETUP(L)</sub>	Setup time for LATCH		15			ns
f <sub>CLK</sub>	Clock frequency		Cascade operation <sup>(1)</sup>			30

**Notes:**

<sup>(1)</sup> If the device is connected in cascade, it may not be possible to achieve the maximum data transfer. Please consider the timings carefully.

### 3 Electrical characteristics

Table 7: Electrical characteristics (V<sub>DD</sub> = 3.3 V to 5 V, T = 25 °C, unless otherwise specified)

Symbol	Parameter	Test conditions	Min.	Typ.	Max.	Unit
V <sub>IH</sub>	Input voltage high level		0.7 V <sub>DD</sub>		V <sub>DD</sub>	V
V <sub>IL</sub>	Input voltage low level		GND		0.3 V <sub>DD</sub>	V
I <sub>OH</sub>	Output leakage current	V <sub>OH</sub> = 20 V			10	μA
V <sub>OL</sub>	Output voltage (serial-OUT)	I <sub>OL</sub> = 1 mA			0.4	V
V <sub>OH</sub>	Output voltage (serial-OUT)	I <sub>OH</sub> = -1 mA	V <sub>DD</sub> -0.4V			V
I <sub>OL1</sub>	Output current	V <sub>O</sub> = 0.3 V, R <sub>ext</sub> = 3.9 kΩ	4.25	5	5.75	mA
I <sub>OL2</sub>		V <sub>O</sub> = 0.3 V, R <sub>ext</sub> = 970 Ω	19	20	21	
I <sub>OL3</sub>		V <sub>O</sub> = 1.3 V, R <sub>ext</sub> = 190 Ω	96	100	104	
ΔI <sub>OL1</sub>	Output current error between bit (all output ON)	V <sub>O</sub> = 0.3 V, R <sub>ext</sub> = 3.9 kΩ		± 5	± 8	
ΔI <sub>OL2</sub>		V <sub>O</sub> = 0.3 V, R <sub>ext</sub> = 970 Ω		± 1.5	± 3	%
ΔI <sub>OL3</sub>		V <sub>O</sub> = 1.3 V, R <sub>ext</sub> = 190 Ω		± 1.2	± 3	
R <sub>SIN(up)</sub>	Pull-up resistor		150	300	600	kΩ
R <sub>SIN(down)</sub>	Pull-down resistor		100	200	400	kΩ
I <sub>DD(SH)</sub>	Shut-down current all latched data = L	V <sub>DD</sub> = 3.3 V		120	170	μA
		V <sub>DD</sub> = 5 V		140	200	
I <sub>DD(OFF1)</sub>	Supply current (OFF)	R <sub>ext</sub> = 970 OUT 0 to 15 = OFF		5		mA
I <sub>DD(OFF2)</sub>		R <sub>ext</sub> = 240 OUT 0 to 15 = OFF		12.5		
I <sub>DD(ON1)</sub>	Supply current (ON)	R <sub>ext</sub> = 970 OUT 0 to 15 = ON		5.5		
I <sub>DD(ON2)</sub>		R <sub>ext</sub> = 240 OUT 0 to 15 = ON		13		
Thermal	Thermal protection			170		°C

Table 8: Switching characteristics

Symbol	Parameter	Test conditions	Min.	Typ.	Max.	Unit	
t <sub>PLH1</sub>	Propagation delay time, CLK- $\overline{\text{OUTn}}$ , LE = H, $\overline{\text{OE}}$ = L	$V_{IH} = V_{DD}$ $V_{IL} = \text{GND}$ $C_L = 10 \text{ pF}$ $I_O = 20 \text{ mA}$ $V_L = 3.0 \text{ V}$ $R_{ext} = 1 \text{ K}\Omega$ $R_L = 60 \Omega$	V <sub>DD</sub> = 3.3 V		35	55	ns
			V <sub>DD</sub> = 5 V		17.5	26	
t <sub>PLH2</sub>	Propagation delay time, LE- $\overline{\text{OUTn}}$ , $\overline{\text{OE}}$ = L		V <sub>DD</sub> = 3.3 V		33.5	52	ns
			V <sub>DD</sub> = 5 V		17	20	
t <sub>PLH3</sub>	Propagation delay time, $\overline{\text{OE}}$ - $\overline{\text{OUTn}}$ , LE = H		V <sub>DD</sub> = 3.3 V		53.5	84.5	ns
			V <sub>DD</sub> = 5 V		28.5	40.5	
t <sub>PLH</sub>	Propagation delay time, CLK-SDO		V <sub>DD</sub> = 3.3 V		19	27.5	ns
			V <sub>DD</sub> = 5 V		13	18.5	
t <sub>PHL1</sub>	Propagation delay time, CLK- $\overline{\text{OUTn}}$ , LE = H, $\overline{\text{OE}}$ = L		V <sub>DD</sub> = 3.3 V		13	19	ns
			V <sub>DD</sub> = 5 V		8.5	12	
t <sub>PHL2</sub>	Propagation delay time, LE- $\overline{\text{OUTn}}$ , $\overline{\text{OE}}$ = L	V <sub>DD</sub> = 3.3 V		10	14.5	ns	
		V <sub>DD</sub> = 5 V		6.5	9		
t <sub>PHL3</sub>	Propagation delay time, $\overline{\text{OE}}$ - $\overline{\text{OUTn}}$ , LE = H	V <sub>DD</sub> = 3.3 V		10.5	15	ns	
		V <sub>DD</sub> = 5 V		7.5	10.5		
t <sub>PHL</sub>	Propagation delay time, CLK-SDO	V <sub>DD</sub> = 3.3 V		23	33	ns	
		V <sub>DD</sub> = 5 V		15.5	21.5		
t <sub>ON</sub>	Output rise time 10~90% of voltage waveform	V <sub>DD</sub> = 3.3 V		23.5	31.5	ns	
		V <sub>DD</sub> = 5 V		9	10.5		
t <sub>OFF</sub>	Output fall time 90~10% of voltage waveform	V <sub>DD</sub> = 3.3 V		4.6	5.5	ns	
		V <sub>DD</sub> = 5 V		3.5	5		
t <sub>r</sub>	CLK rise time <sup>(1)</sup>				5000	ns	
t <sub>f</sub>	CLK fall time <sup>(1)</sup>				5000	ns	

**Notes:**

<sup>(1)</sup> In order to achieve high cascade data transfer, please consider tr/tf timings carefully.

### 4 Equivalent circuit and outputs

Figure 2: OE/DM2 terminal

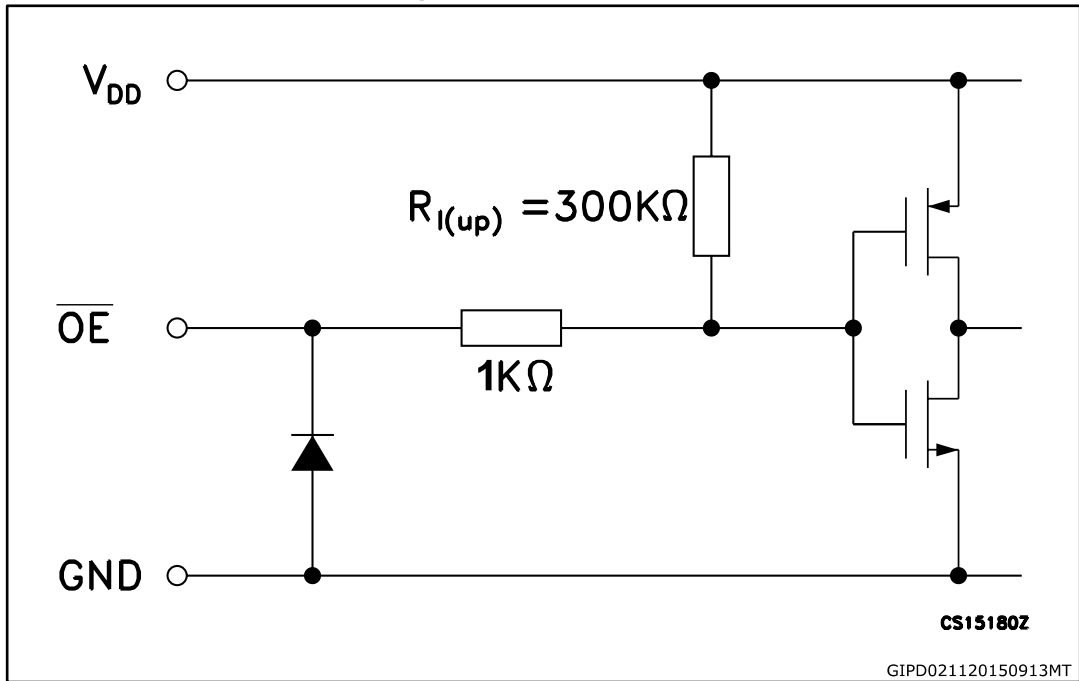

Figure 3: LE/DM1 terminal

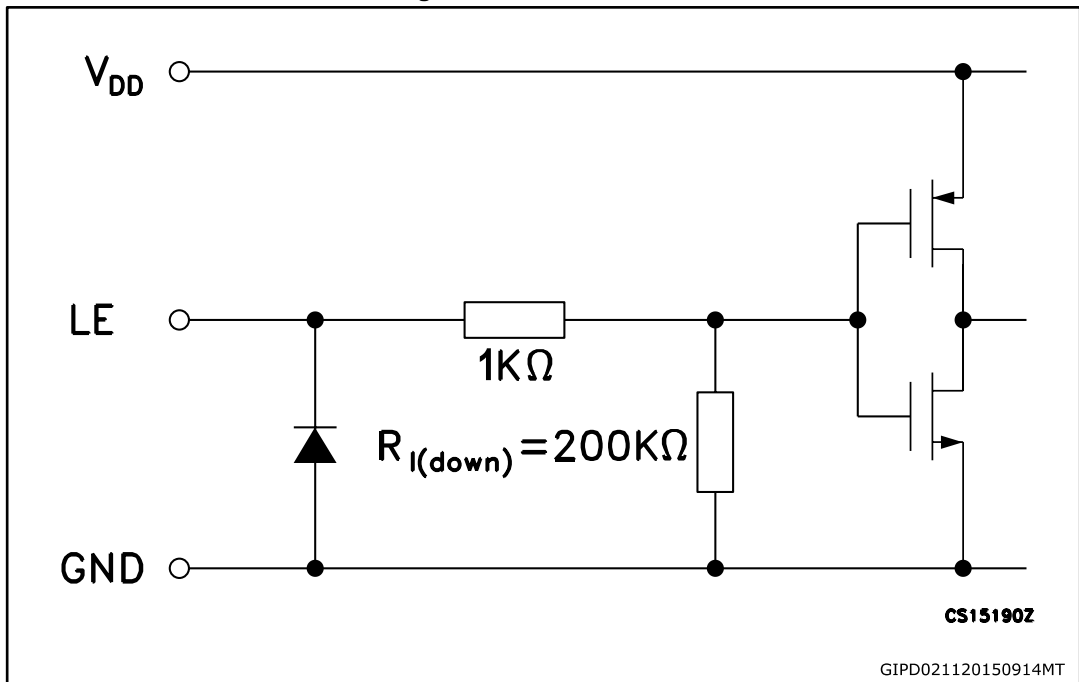

Figure 4: CLK, SDI terminal

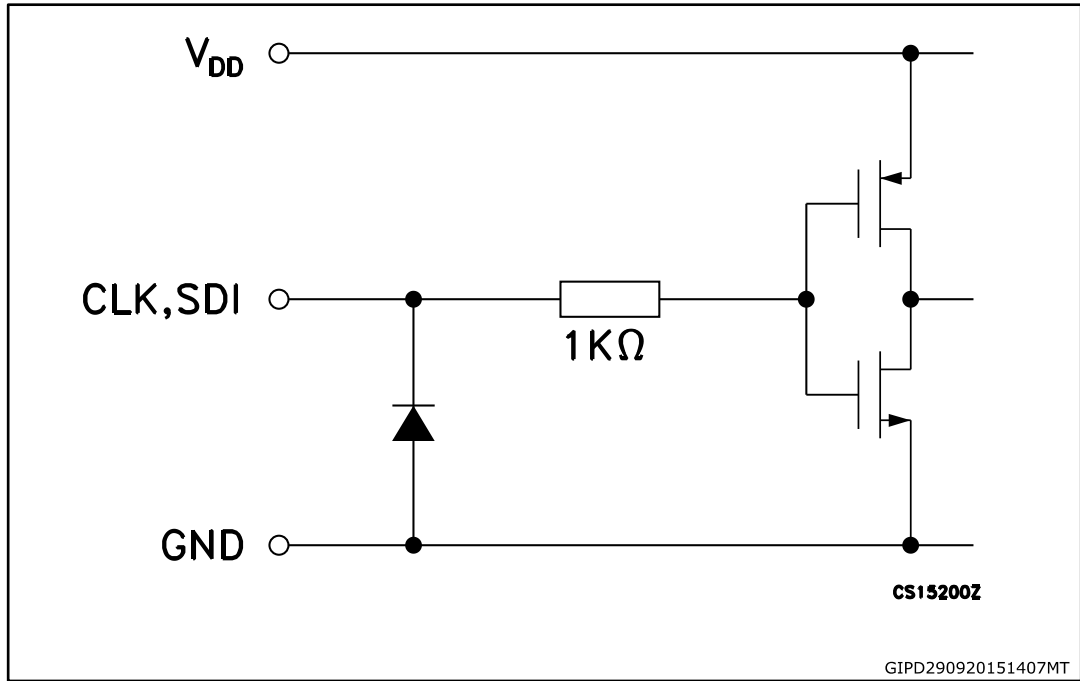

Figure 5: SDO terminal

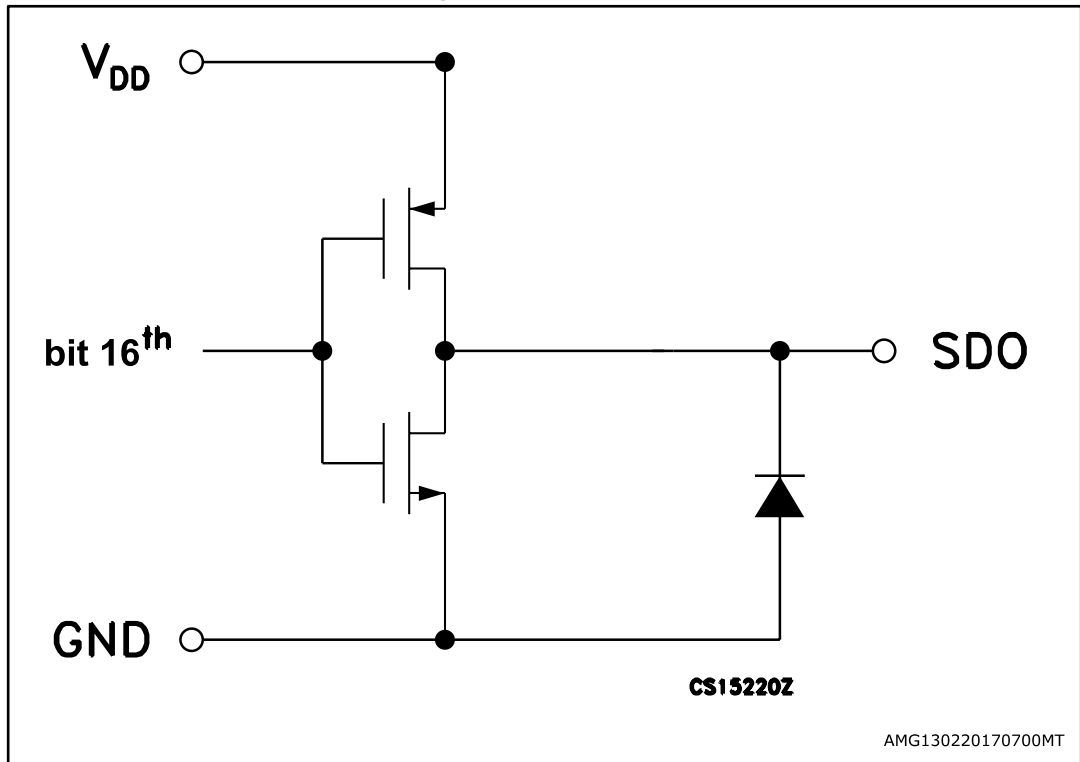
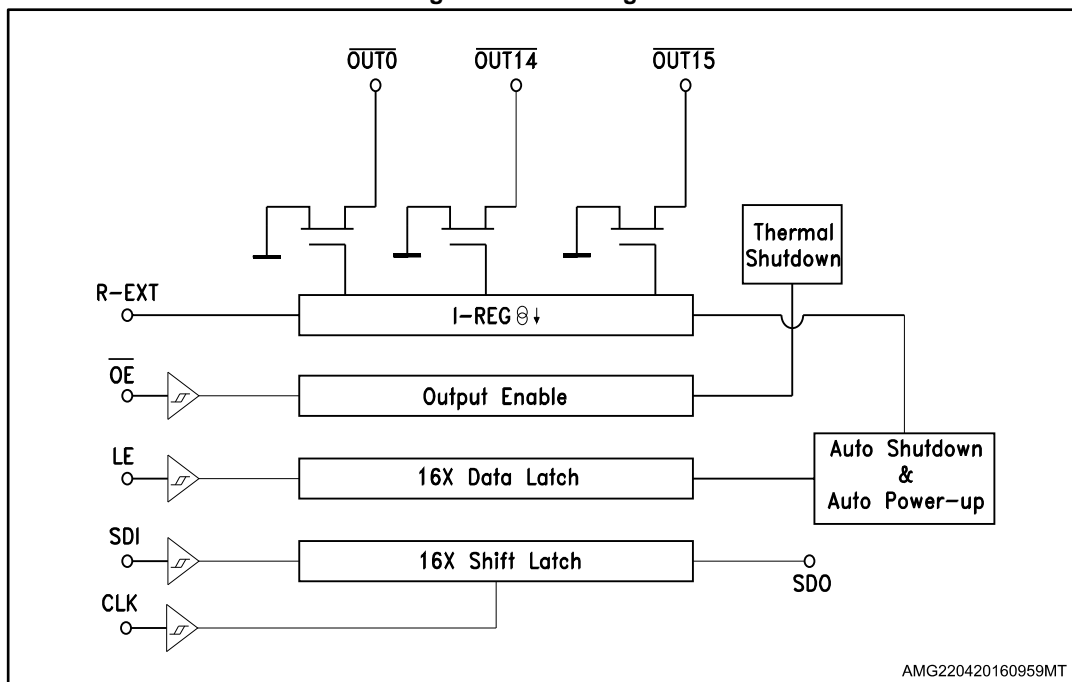

Figure 6: Block diagram



## 5 Timing diagrams

Table 9: Truth table

CLOCK	LE	$\overline{OE}$	SERIAL-IN	$\overline{OUT0}$ ..... $\overline{OUT7}$ ..... $\overline{OUT15}$	SDO
$\downarrow$	H	L	Dn	Dn ..... Dn - 7 ..... Dn - 15	Dn - 15
$\downarrow$	L	L	Dn + 1	No change	Dn - 14
$\downarrow$	H	L	Dn + 2	Dn + 2 ..... Dn - 5 ..... Dn - 13	Dn - 13
$\downarrow$	X	L	Dn + 3	Dn + 2 ..... Dn - 5 ..... Dn - 13	Dn - 13
$\downarrow$	X	H	Dn + 3	OFF	Dn - 13



OUTn = ON when Dn = H OUTn = OFF when Dn = L.

Figure 7: Timing diagram

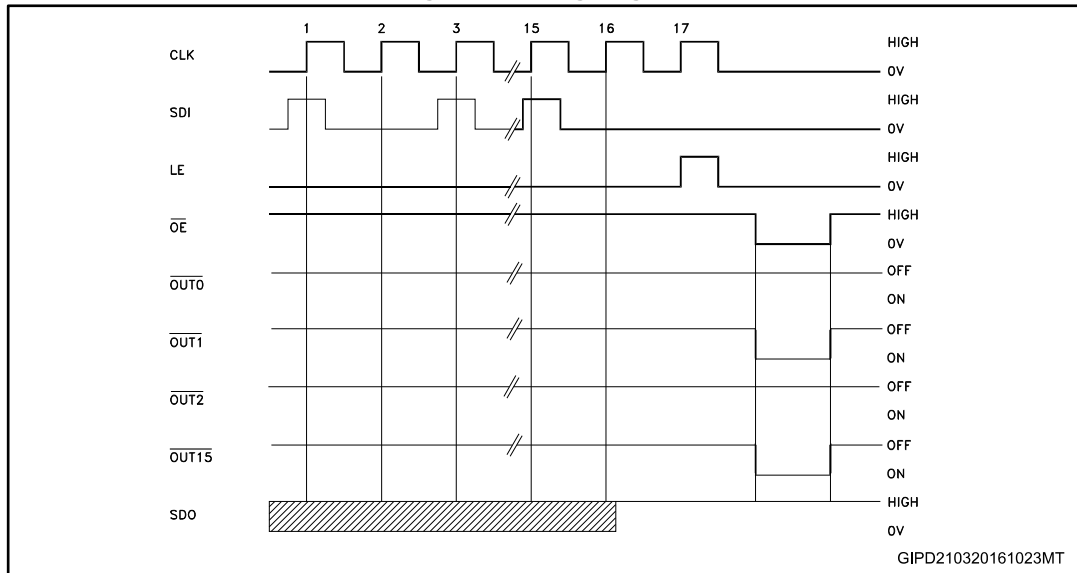

1 Latch and output enable terminals are Level-sensitive and are not synchronized with rising or falling edge of CLK signal.

2 When LE terminal is at low level, the latch circuit holds previous set of data.

3 When LE terminal is at high level, the latch circuit refreshes new set of data from SDI chain.

4 When  $\overline{OE}$  is at low level the output terminals Out 0 to Out 15 respond to data in the latch circuits, either '1' for ON or '0' for OFF.

5 When  $\overline{OE}$  is at high level, all output terminals are switched OFF.

Table 10: Truth table

CLOCK	LE	SDI <sub>0</sub> ..... SDI <sub>7</sub> ..... SDI <sub>15</sub>	SH	Auto power-up	OUTn
	H	All = L	Active	Not active	OFF
	L	No change	No change	No change	No change
	H	One or more = H	Not active	Active	X



At the power-up the device starts in shut-down mode.

Figure 8: Clock, serial-in, serial-out

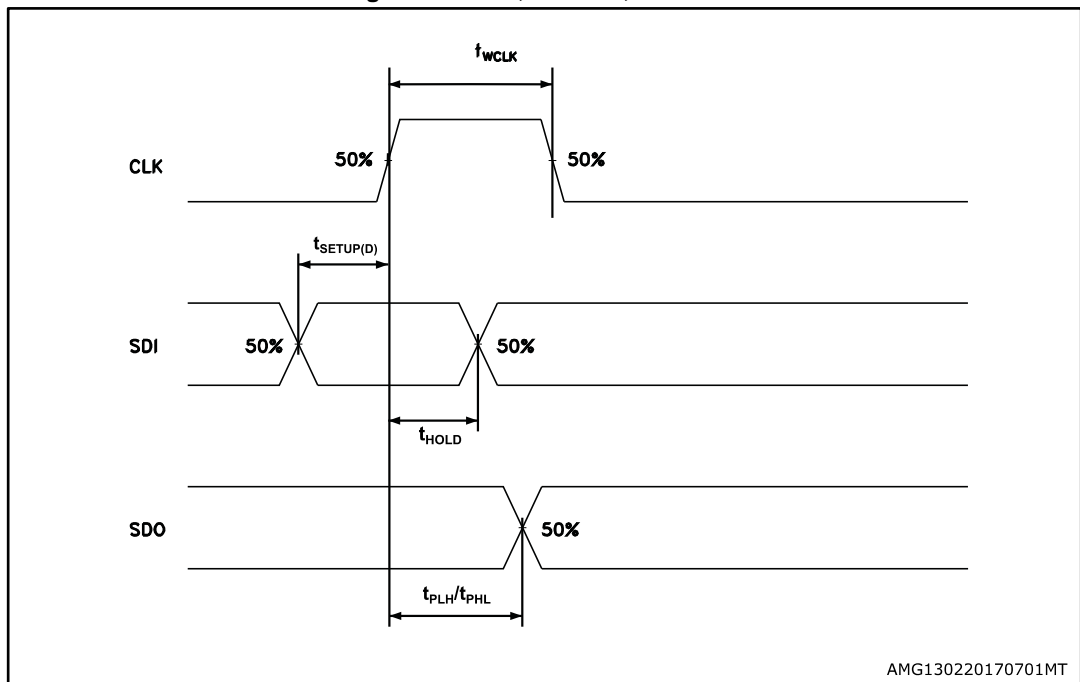

AMG130220170701MT

Figure 9: Clock, serial-in, latch, enable, outputs

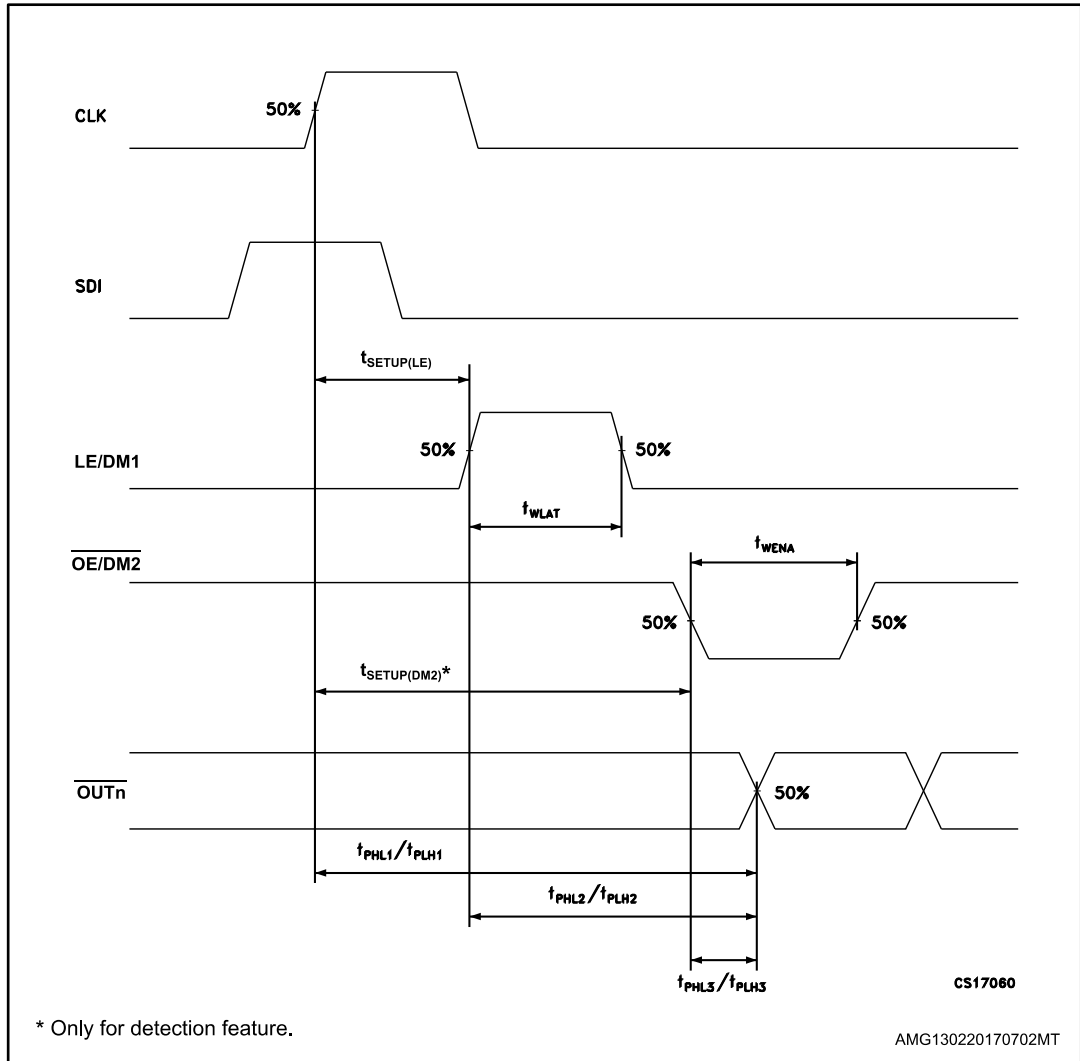
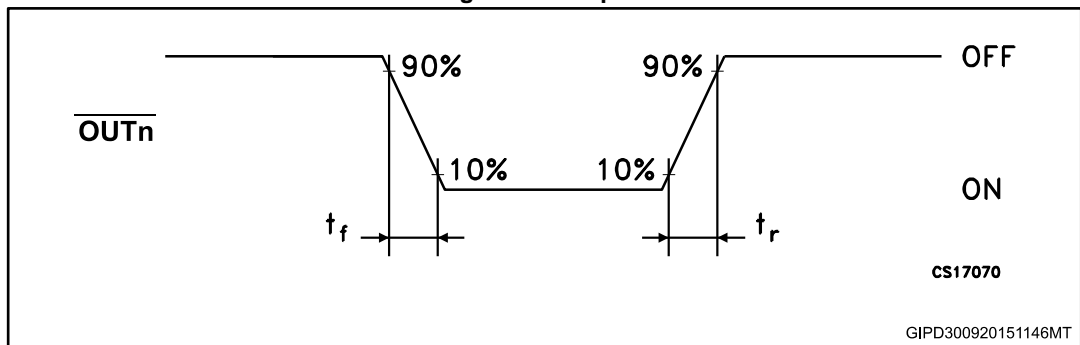
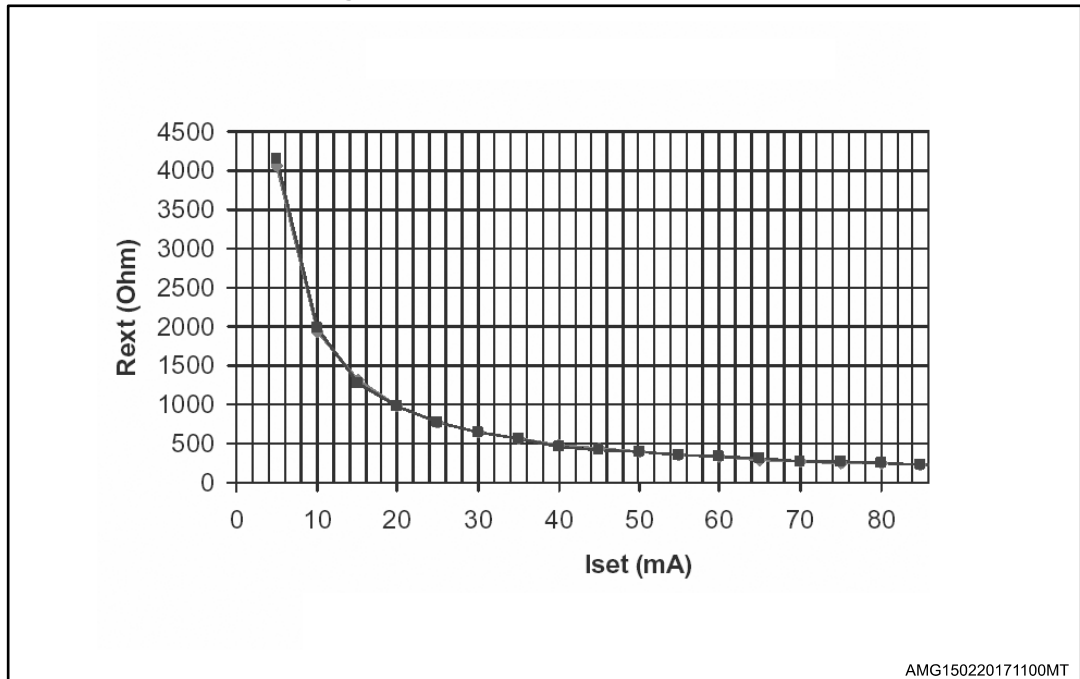

Figure 10: Outputs



## 6 Typical characteristics

Figure 11: Output current-R-EXT resistor



AMG150220171100MT

Table 11: Output current-R-EXT resistor

R-EXT (Ω)	Output current (mA)
976	20
780	25
652	30
560	35
488	40
433	45
389	50
354	55
325	60
300	65
278	70
259	75
241	80
229	85
215	90

Figure 12: Output current vs  $\pm \Delta I_{OL}(\%)$

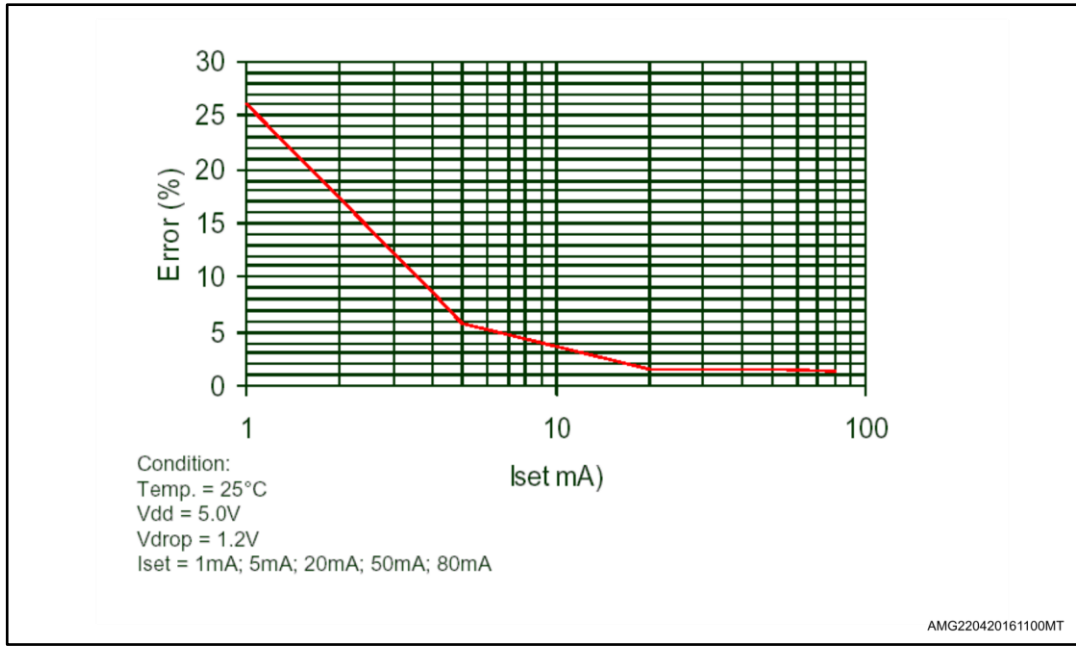

Figure 13: I<sub>SET</sub> vs drop out voltage (V<sub>drop</sub>)

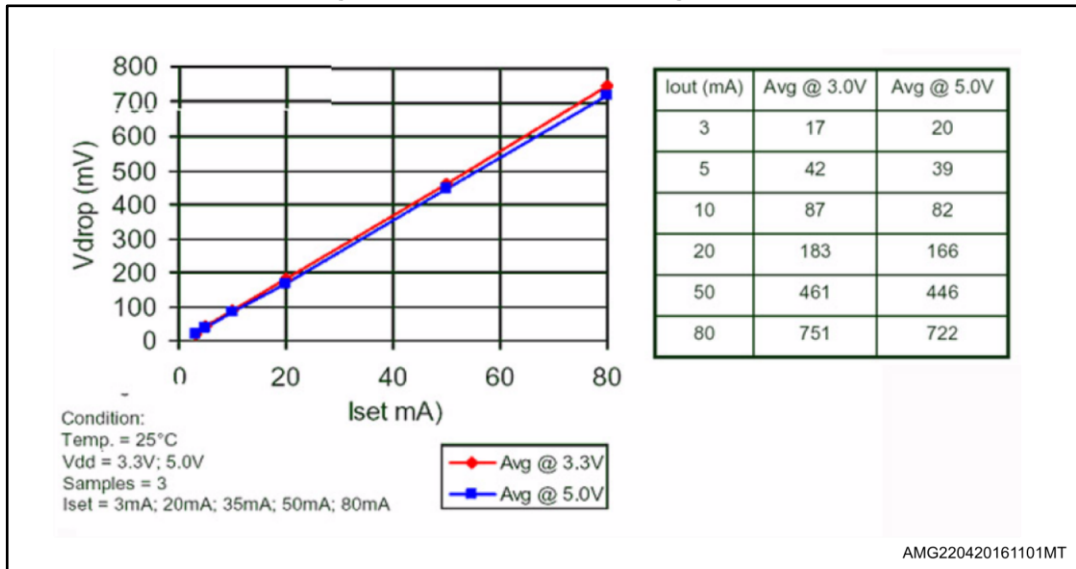

Figure 14: I<sub>DD</sub> ON/OFF

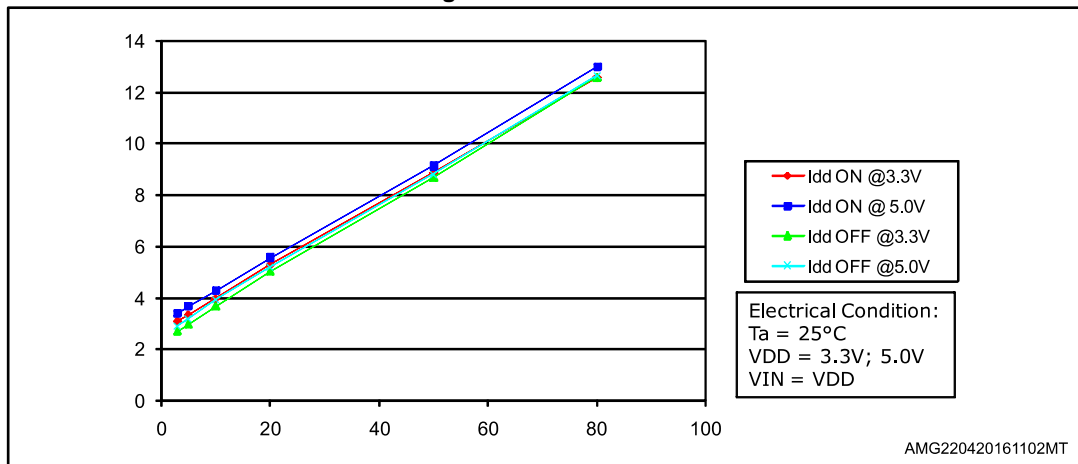
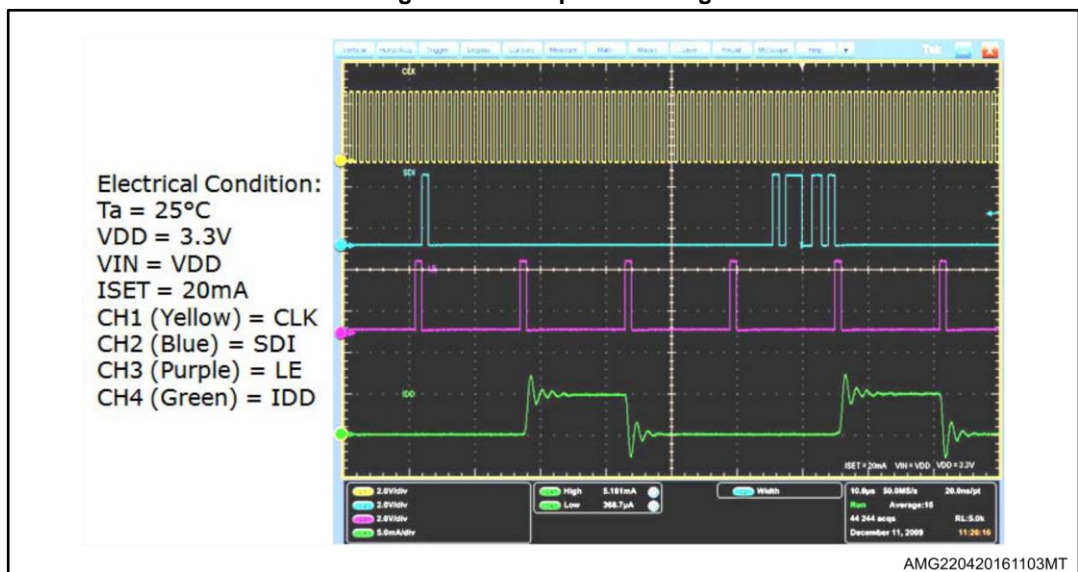
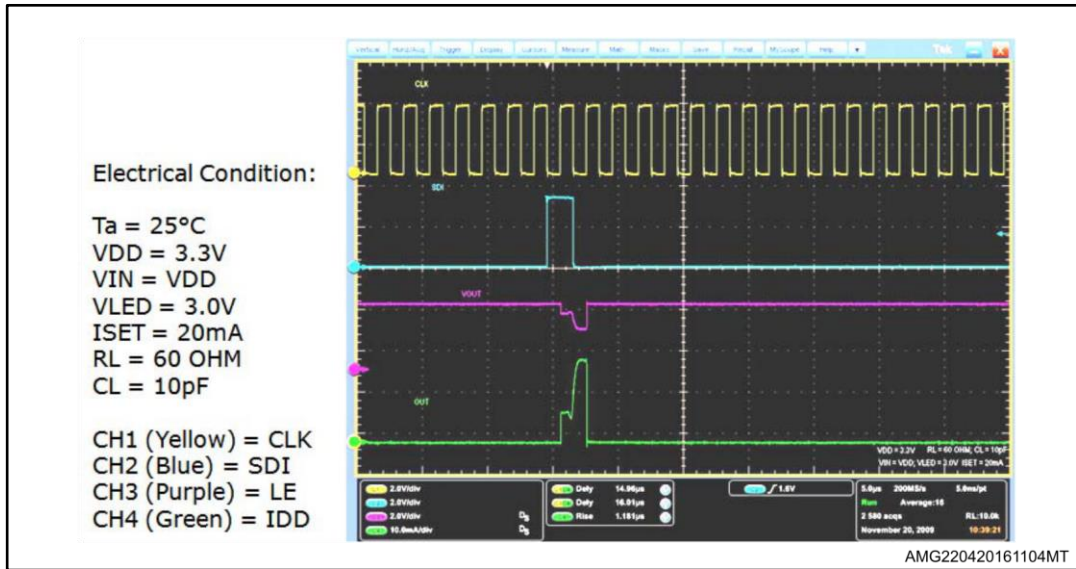

Figure 15: Auto power saving



Auto power-saving feature minimizes the quiescent current if no active data is detected on the latches and auto-power-up the device at fist active data latched.

Figure 16: First output ON after switching from auto power saving to normal mode operating condition



When the device goes from auto power saving to normal operative condition, the first output that switch ON shows TON condition as seen in the plot above.

# 7 Test circuit

Figure 17: DC characteristic

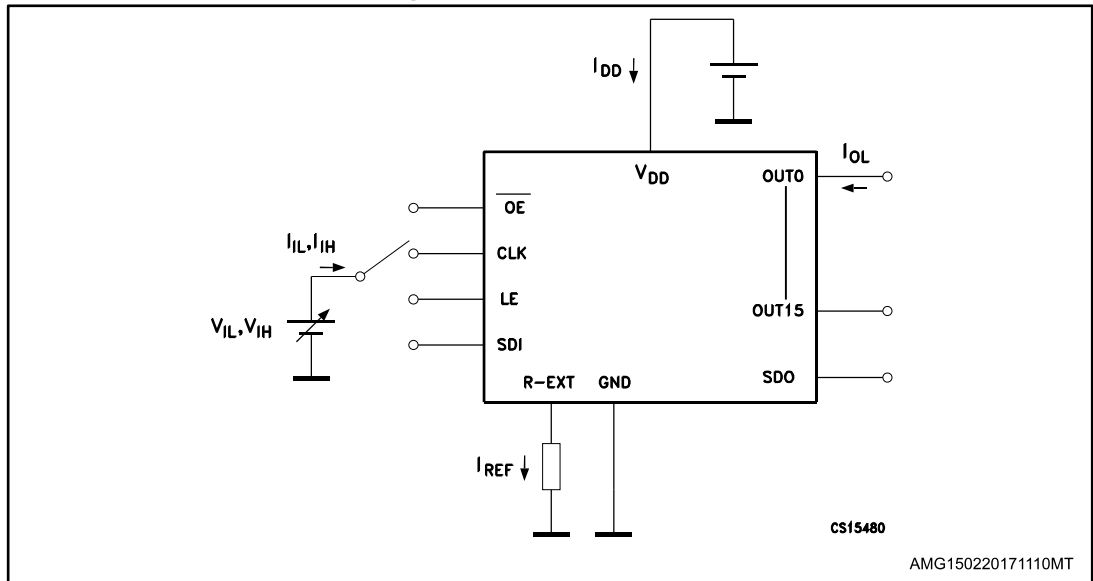

Figure 18: AC characteristic

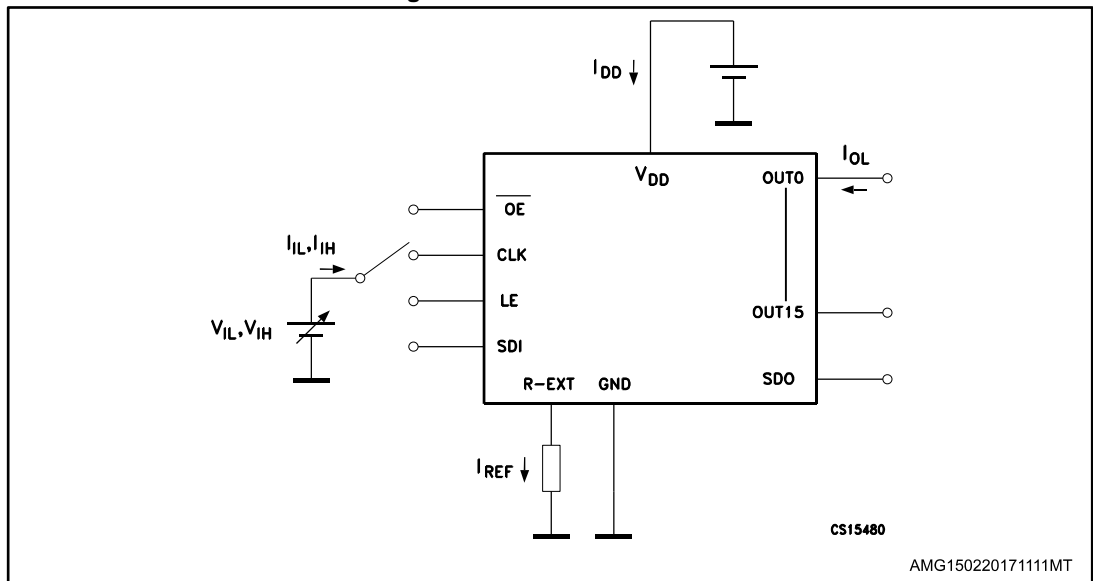
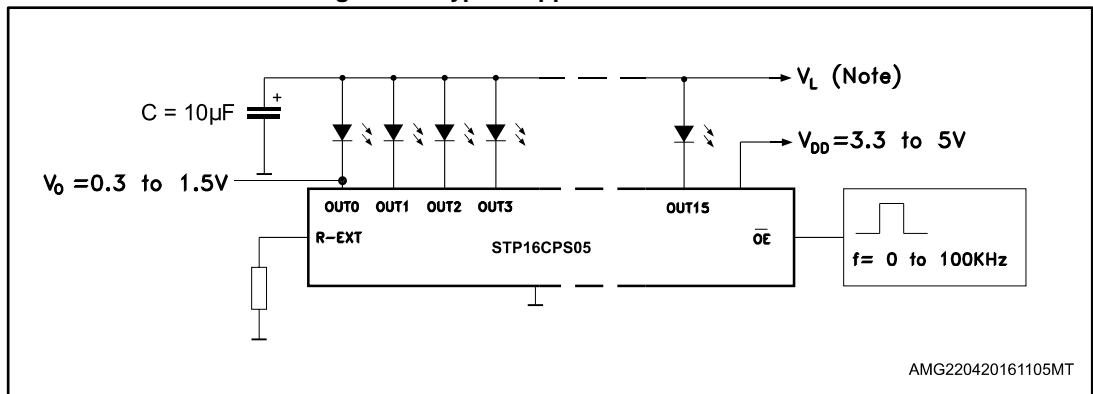

Figure 19: Typical application schematic



$V_L$  will be determined by the  $V_F$  of the LEDs.

Figure 20: Turn ON output current characteristics<sup>(1)</sup>



AMG220420161106MT

Figure 21: Turn OFF output current characteristics<sup>(2)</sup>

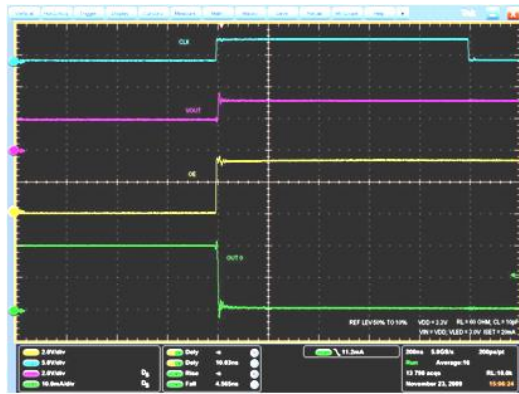

AMG220420161106MT

**Notes:**

- (1) Reference level for the  $T_{ON}$  characteristics is 50 % of OE signal to 90 % of output current.
- (2) Reference level for the  $T_{OFF}$  characteristics is 50 % of OE signal to 10 % of output current.

## 8 Package information

In order to meet environmental requirements, ST offers these devices in different grades of ECOPACK® packages, depending on their level of environmental compliance. ECOPACK® specifications, grade definitions and product status are available at: [www.st.com](http://www.st.com). ECOPACK® is an ST trademark.

### 8.1 QSOP-24 package information

Figure 22: QSOP-24 package outline

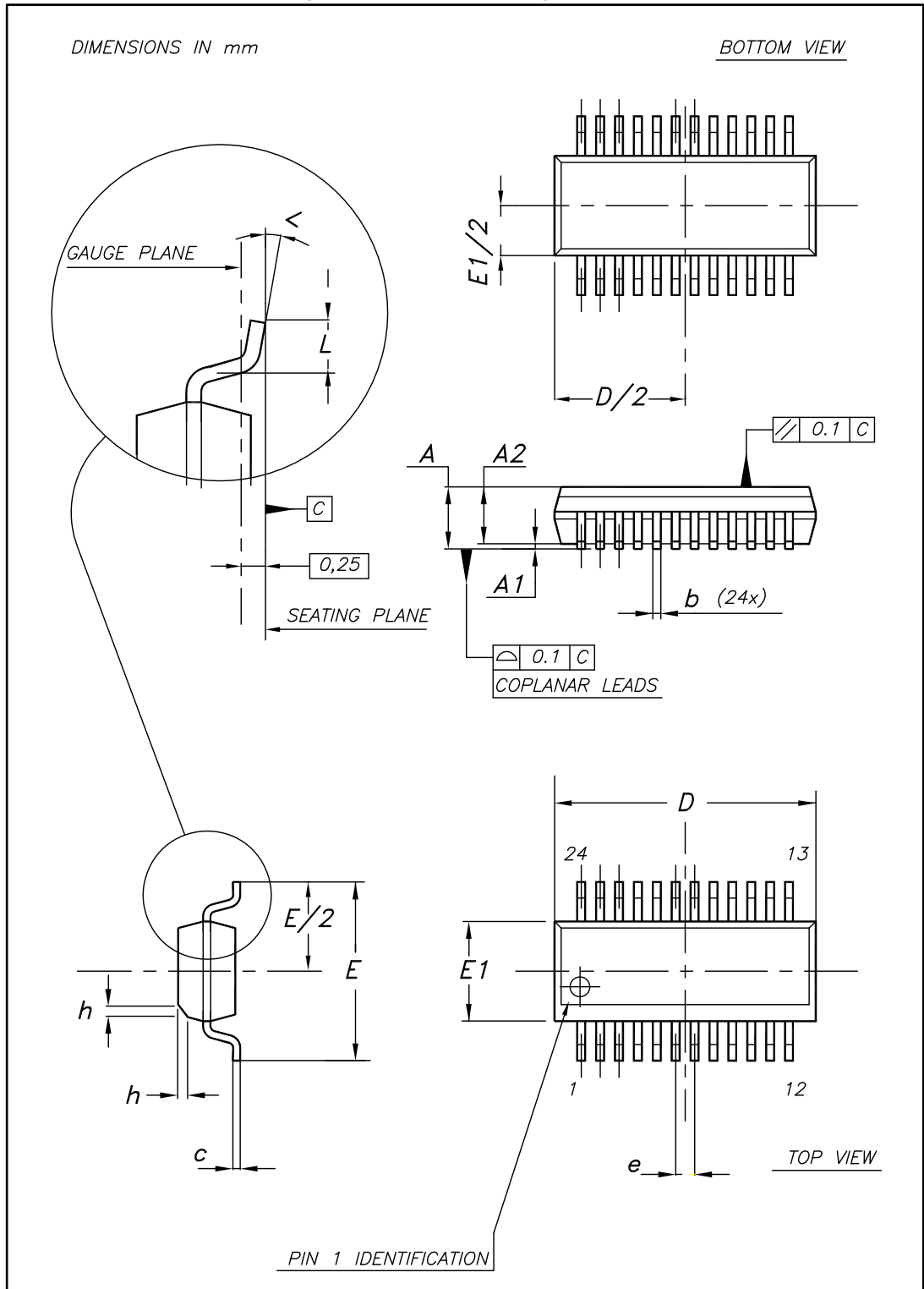

Table 12: QSOP-24 mechanical data

Dim.	mm		
	Min.	Typ.	Max.
A	1.54	1.62	1.73
A1	0.10	0.15	0.25
A2		1.47	
b	0.20		0.31
c	0.17		0.254
D	8.56	8.66	8.76
E	5.80	6.00	6.20
E1	3.80	3.91	4.01
e		0.635	
L	0.40	0.635	0.89
h	0.25	0.33	0.41
<	0°		8°

### 8.2 SO-24 package information

Figure 23: SO-24 package outline

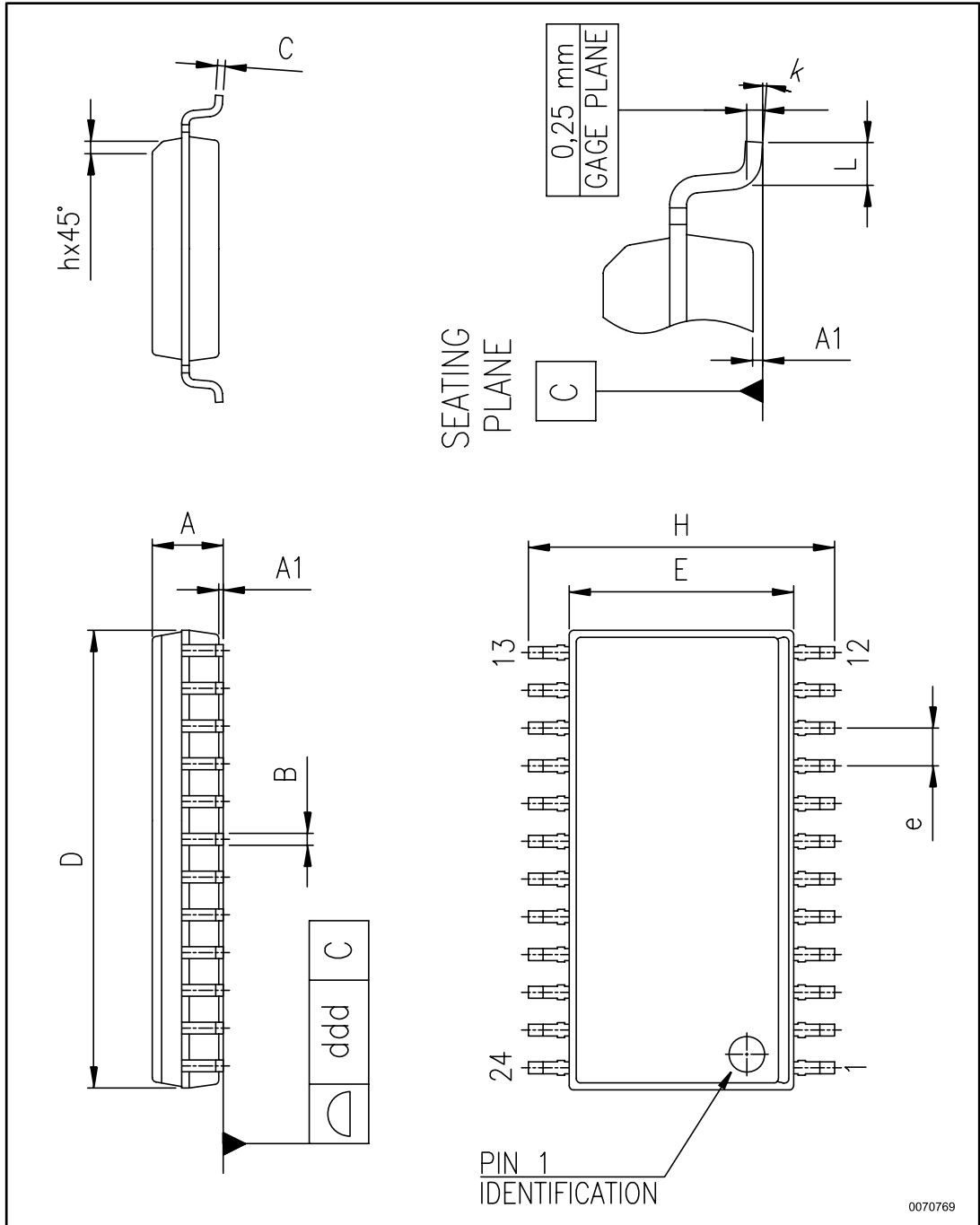
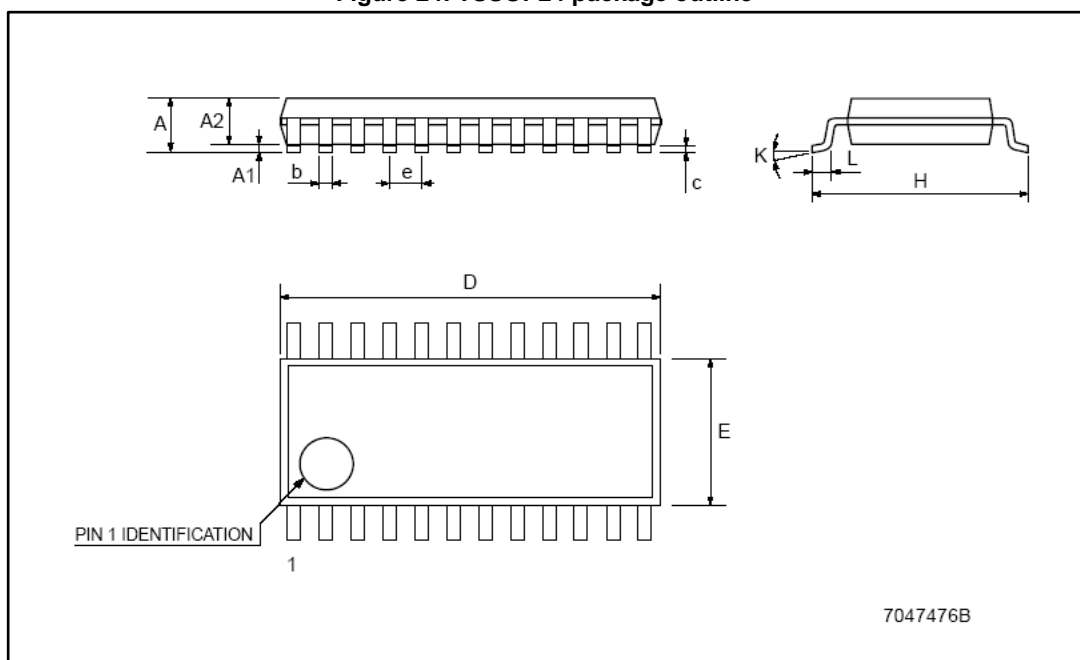

Table 13: SO-24 mechanical data

Dim.	mm		
	Min.	Typ.	Max.
A	2.35		2.65
A1	0.10		0.30
B	0.33		0.51
C	0.23		0.32
D	15.20		15.60
E	7.40		7.60
e		1.27	
H	10.00		10.65
h	0.25		0.75
L	0.40		1.27
k	0		8
ddd			0.10

### 8.3 TSSOP24 package information

Figure 24: TSSOP24 package outline



7047476B

Table 14: TSSOP24 mechanical data

Dim.	mm		
	Min.	Typ.	Max.
A			1.1
A1	0.05		0.15
A2		0.9	
b	0.19		0.30
c	0.09		0.20
D	7.7		7.9
E	4.3		4.5
e		0.65 BSC	
H	6.25		6.5
K	0°		8°
L	0.50		0.70

### 8.4 TSSOP24 exposed pad package information

Figure 25: TSSOP24 exposed pad package outline

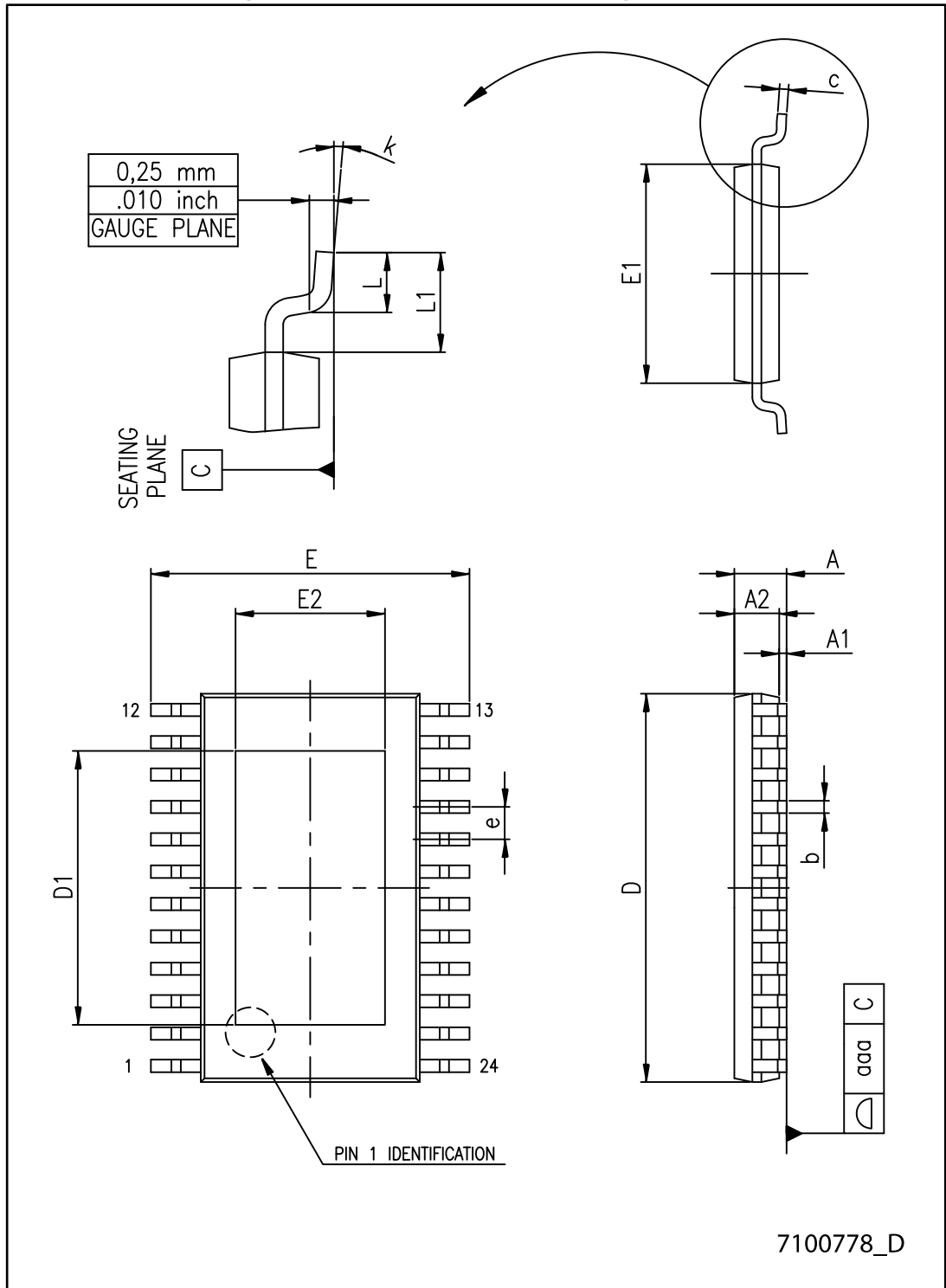

Table 15: TSSOP24 exposed pad mechanical data

Dim.	mm		
	Min.	Typ.	Max.
A			1.20
A1			0.15
A2	0.80	1.00	1.05
b	0.19		0.30
c	0.09		0.20
D	7.70	7.80	7.90
D1	4.80	5.00	5.2
E	6.20	6.40	6.60
E1	4.30	4.40	4.50
E2	3.00	3.20	3.40
e		0.65	
L	0.45	060	075
L1		1.00	
k	0°		8°
aaa			0.10

### 8.5 TSSOP24, TSSOP24 exposed pad and SO-24 packing information

Figure 26: TSSOP24, TSSOP24 exposed pad and SO-24 reel outline

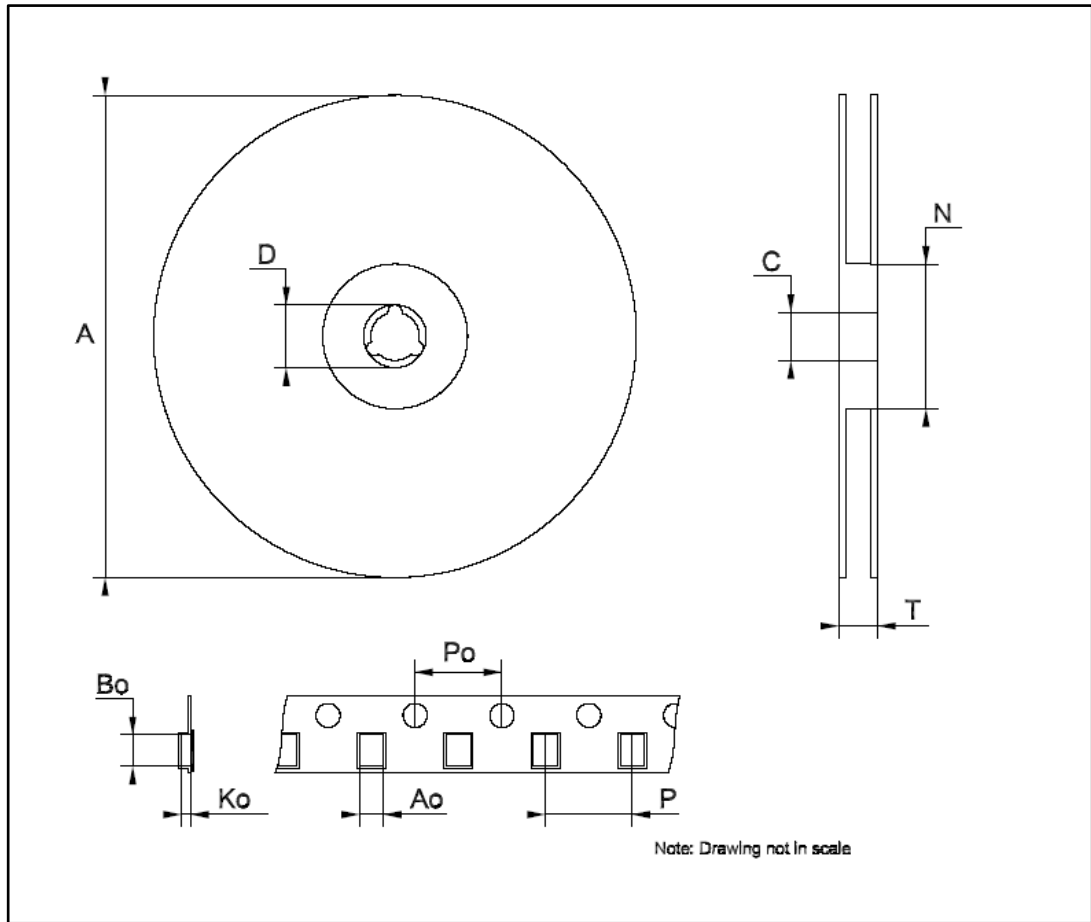

Table 16: TSSOP24 and TSSOP24 exposed pad tape and reel mechanical data

Dim.	mm		
	Min.	Typ.	Max.
A		-	330
C	12.8	-	13.2
D	20.2	-	
N	60	-	
T		-	22.4
Ao	6.8	-	7
Bo	8.2	-	8.4
Ko	1.7	-	1.9
Po	3.9	-	4.1
P	11.9	-	12.1

Table 17: SO-24 tape and reel mechanical data

Dim.	mm		
	Min.	Typ.	Max.
A		-	330
C	12.8	-	13.2
D	20.2	-	
N	60	-	
T		-	30.4
Ao	10.8	-	11.0
Bo	15.7	-	15.9
Ko	2.9	-	3.1
Po	3.9	-	4.1
P	11.9	-	12.1

## 9 Revision history

**Table 18: Document revision history**

Date	Revision	Changes
28-Jul-2006	1	First release
22-Dec-2006	2	Final datasheet
17-May-2007	3	Updated Table 8 on page 8
10-Jul-2007	4	Updated Table 9: Truth table on page 11
28-Feb-2008	5	Updated Table 19: TSSOP24 exposed pad on page 25 Added QSOP-24 package information Table 14 and Figure 20 on page 21
19-Jan-2010	6	Updated Table 6 on page 6
17-Jun-2014	7	Updated Section 8: Package mechanical data. Added Section 9: Packaging mechanical data. Minor text changes.
24-Mar-2017	8	Updated <i>Figure 5: "SDO terminal"</i> , <i>Figure 8: "Clock, serial-in, serial-out"</i> , <i>Figure 9: "Clock, serial-in, latch, enable, outputs"</i> and <i>Section 8.1: "QSOP-24 package information"</i> . Minor text changes.

**IMPORTANT NOTICE – PLEASE READ CAREFULLY**

STMicroelectronics NV and its subsidiaries ("ST") reserve the right to make changes, corrections, enhancements, modifications, and improvements to ST products and/or to this document at any time without notice. Purchasers should obtain the latest relevant information on ST products before placing orders. ST products are sold pursuant to ST's terms and conditions of sale in place at the time of order acknowledgement.

Purchasers are solely responsible for the choice, selection, and use of ST products and ST assumes no liability for application assistance or the design of Purchasers' products.

No license, express or implied, to any intellectual property right is granted by ST herein.

Resale of ST products with provisions different from the information set forth herein shall void any warranty granted by ST for such product.

ST and the ST logo are trademarks of ST. All other product or service names are the property of their respective owners.

Information in this document supersedes and replaces information previously supplied in any prior versions of this document.

© 2017 STMicroelectronics – All rights reserved

## Looking for pricing, stock, or lifecycle information?

Click below to explore more details on WIN SOURCE:

- ⊖ [View STP16CPS05TTR on WIN SOURCE](#)
- ⊖ [STMicroelectronics Information](#)

## Optimize Your Supply Chain with WIN SOURCE Solutions

- ✓ Global Sourcing Solution
- ✓ Obsolete Management
- ✓ Cost Control Management
- ✓ Shortage Management
- ✓ Alternative Solution
- ✓ Excess Inventory Management