



**THE DATASHEET OF
INA168QDBVRQ1**



INA1x8-Q1 Automotive-Grade, High-Side, Current-Output, Current-Shunt Monitor

1 Features

- Qualified for Automotive Applications
- AEC-Q100 Qualified With the Following Results:
 - Device Temperature Grade 1: -40°C to 125°C Ambient Operating Temperature Range
 - Device HBM ESD Classification Level 2
 - Device CDM ESD Classification Level C6
- Complete Unipolar High-Side Current-Measurement Circuit
- Wide Supply and Common-Mode Ranges:
 - INA138-Q1: 2.7 V to 36 V
 - INA168-Q1: 2.7 V to 60 V
- Independent Supply and Input Common-Mode Voltages
- Single Resistor Gain Set
- Low Quiescent Current (25 μA Typical)
- Wide Temperature Range: -40°C to $+125^{\circ}\text{C}$
- Packages: TSSOP-8, SOT-23-5 (INA168-Q1)

2 Applications

- Electric Power Steering (EPS) Systems
- Body Control Modules
- Brake Systems
- Electronic Stability Control (ESC) Systems

3 Description

The INA138-Q1 and INA168-Q1 (INA1x8-Q1) devices are high-side, unidirectional, current sense amplifiers. Wide input common-mode voltage range, low quiescent current, and TSSOP and SOT-23 packaging enable use in a variety of applications.

Input common-mode and power-supply voltages are independent, and range from 2.7 V to 36 V for the INA138-Q1, and 2.7 V to 60 V for the INA168-Q1. Quiescent current is only 25 μA , which permits connecting the power supply to either side of the current-measurement shunt with minimal error.

The device converts a differential input voltage to a current output. This current is converted back to a voltage with an external load resistor that sets any gain from 1 to over 100. Although designed for current shunt measurement, the circuit invites creative applications in measurement and level shifting.

Both devices are available in a TSSOP-8 package. The INA168-Q1 is also available in a SOT-23-5 package. Both devices are specified for the -40°C to $+125^{\circ}\text{C}$ temperature range.

Device Information⁽¹⁾

PART NUMBER	PACKAGE	BODY SIZE (NOM)
INA138-Q1	TSSOP (8)	4.40 mm x 3.00 mm
INA168-Q1		
INA168-Q1	SOT-23 (5)	2.90 mm x 1.60 mm

(1) For all available packages, see the package option addendum at the end of the data sheet.

Typical Application Circuit

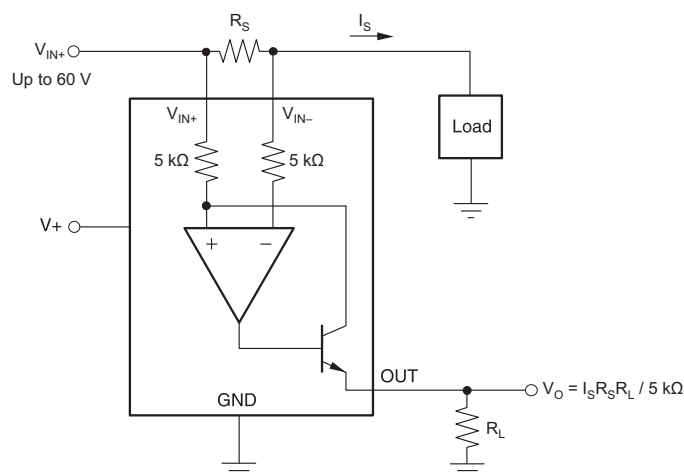

Table of Contents

1 Features 1 2 Applications 1 3 Description 1 4 Revision History 2 5 Pin Configuration and Functions 4 6 Specifications 5 6.1 Absolute Maximum Ratings 5 6.2 ESD Ratings 5 6.3 Recommended Operating Conditions 5 6.4 Thermal Information 6 6.5 Electrical Characteristics 6 6.6 Typical Characteristics 7 7 Detailed Description 9 7.1 Overview 9 7.2 Functional Block Diagram 9 7.3 Feature Description 10 7.4 Device Functional Modes 10	8 Application and Implementation 10 8.1 Application Information 10 8.2 Typical Applications 12 9 Power Supply Recommendations 19 10 Layout 19 10.1 Layout Guidelines 19 10.2 Layout Example 19 11 Device and Documentation Support 20 11.1 Documentation Support 20 11.2 Related Links 20 11.3 Receiving Notification of Documentation Updates 20 11.4 Community Resources 20 11.5 Trademarks 20 11.6 Electrostatic Discharge Caution 20 11.7 Glossary 20 12 Mechanical, Packaging, and Orderable Information 20
--	--

4 Revision History

NOTE: Page numbers for previous revisions may differ from page numbers in the current version.

Changes from Revision I (January 2018) to Revision J	Page
• Added "V _{SENSE} =" to differential analog input voltage label in <i>Absolute Maximum Ratings</i> table 5	5
• Changed maximum differential analog input voltage from 2 V to 40 V in <i>Absolute Maximum Ratings</i> table 5	5
• Added new note 2 to <i>Absolute Maximum Ratings</i> table 5	5
• Added output current row with upper limit of 400 μ A to <i>Absolute Maximum Ratings</i> table 5	5

Changes from Revision H (May 2016) to Revision I	Page
• Changed <i>Thermal Information</i> data for INA168-Q1 DBV device 6	6

Changes from Revision G (January 2014) to Revision H	Page
• Changed <i>Application</i> bullets 1	1
• Added <i>Device Information</i> , <i>ESD Ratings</i> , <i>Recommended Operating Conditions</i> , and <i>Thermal Information</i> tables, and <i>Feature Description</i> , <i>Application and Implementation</i> , <i>Power Supply Recommendations</i> , <i>Layout</i> , <i>Device and Documentation Support</i> , and <i>Mechanical, Packaging, and Orderable Information</i> sections 1	1
• Added new automotive qualification features bullet, and deleted old bullet 1	1
• Added pin names to all figures and removed all pin numbers 1	1
• Deleted Ordering Information table; information available in the Package Option Addendum at the end of this data sheet 4	4
• Added missing minus sign to V _{IN-} pin in pin configuration figures 4	4
• Deleted thermal resistance from <i>Absolute Maximum Ratings</i> table; see new <i>Thermal Information</i> table 5	5
• Changed R _{θJA} value for both packages 6	6
• Changed V _S to V+ throughout data sheet for consistency 6	6
• Changed R _{OUT} in <i>Electrical Characteristics</i> table to R _L for consistency 6	6
• Changed V _{IN} to V _{SENSE} in Figure 4 7	7
• Deleted V _S symbol from text regarding voltage drop in <i>Operation</i> section 10	10
• Changed 10 μ A to 100 μ A in <i>Operation</i> section (typo) 10	10
• Changed Figure 9; removed incorrect pin numbers, and moved embedded table to outside of figure 11	11

- Changed Figure 10..... 12
 - Changed Figure 15..... 16
-

Changes from Revision F (November 2013) to Revision G**Page**

- Changed part number from IN168-Q1 to INA168-Q1 in multiple locations throughout the document..... 1
-

Changes from Revision E (September 2012) to Revision F**Page**

- Corrected Y-axis label of QUIESCENT CURRENT versus POWER-SUPPLY VOLTAGE graph 7
-

5 Pin Configuration and Functions

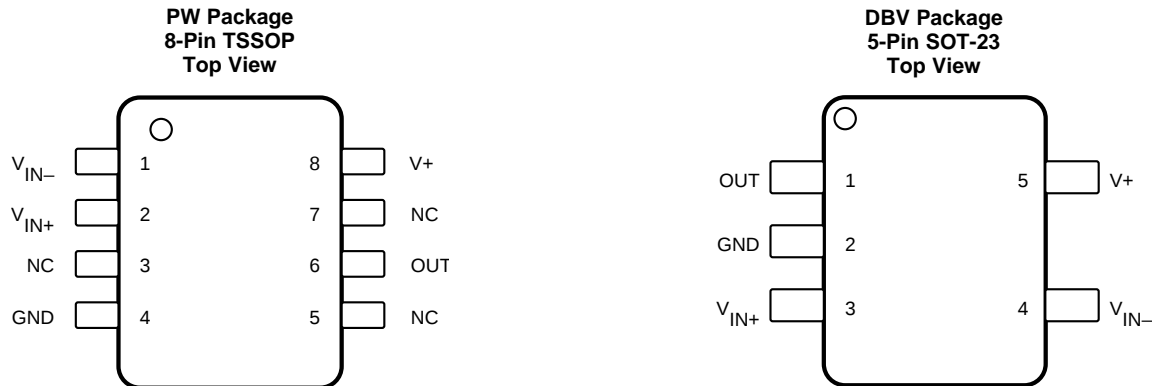

Pin Functions

NAME	PIN		I/O	DESCRIPTION
	INA138-Q1, INA168-Q1	INA168-Q1		
	TSSOP-8	SOT-23-5		
GND	4	2	—	Ground
NC	3, 5, 7	—	—	No internal connection
OUT	6	1	O	Output current
V+	8	5	I	Power-supply voltage
V _{IN-}	1	4	I	Negative input voltage
V _{IN+}	2	3	I	Positive input voltage

6 Specifications

6.1 Absolute Maximum Ratings

over operating free-air temperature range (unless otherwise noted)⁽¹⁾

			MIN	MAX	UNIT	
Voltage	Supply, V ₊	INA138-Q1	-0.3	60	V	
		INA168-Q1	-0.3	75		
	Analog inputs, V _{IN+} , V _{IN-}	Common-mode	INA138-Q1	-0.3		60
			INA168-Q1	-0.3		75
		Differential, V _{SENSE} = (V _{IN+} - V _{IN-}) ⁽²⁾		-40		40
	Analog output, O _{UT}		-0.3	40		
Current	Output current, I _{OUT} ⁽²⁾			400	μA	
Temperature	Operating, T _A		-55	150	°C	
	Junction, T _J			150		
	Storage, T _{stg}		-65	150		

- (1) Stresses beyond those listed under *Absolute Maximum Ratings* may cause permanent damage to the device. These are stress ratings only, and functional operation of the device at these or any other conditions beyond those indicated under *Recommended Operating Conditions* is not implied. Exposure to absolute-maximum-rated conditions for extended periods may affect device reliability.
- (2) Use the following equation to make sure that the maximum value of I_{OUT} in a given application is less than 400 μA:

$$I_{OUT,MAX} = \text{MIN} \left(\frac{V_{SENSE,MAX}}{5 \text{ k}\Omega}, \frac{V_{IN+,MAX}}{10 \text{ k}\Omega + R_{LOAD}}, \frac{V_{+,MAX}}{5 \text{ k}\Omega + R_{LOAD}} \right)$$

where:

- I_{OUT,MAX} is the estimated maximum value of I_{OUT}
- V_{SENSE,MAX} is the maximum possible value of the differential input voltage in the application
- V_{IN+,MAX} is the maximum possible value of V_{IN+} in the application
- V_{+,MAX} is the maximum possible value of V₊ in the application
- R_{LOAD} is the value of the load resistor in kΩ

6.2 ESD Ratings

		VALUE	UNIT
V _(ESD)	Electrostatic discharge	Human-body model (HBM), per AEC Q100-002 ⁽¹⁾	±2000
		Charged-device model (CDM), per AEC Q100-011	±1000

- (1) AEC Q100-002 indicates that HBM stressing shall be in accordance with the ANSI/ESDA/JEDEC JS-001 specification.

6.3 Recommended Operating Conditions

over operating free-air temperature range (unless otherwise noted)

		MIN	NOM	MAX	UNIT
Supply voltage, V ₊	INA138-Q1	2.7	5	36	V
	INA168-Q1	2.7	5	60	
Common-mode voltage	INA138-Q1	2.7	12	36	V
	INA168-Q1	2.7	12	60	
Operating temperature, T _A		-40	25	125	°C

6.4 Thermal Information

THERMAL METRIC ⁽¹⁾		INA138-Q1, INA168-Q1	INA168-Q1	UNIT
		PW (TSSOP)	DBV (SOT-23)	
		8 PINS	5 PINS	
$R_{\theta JA}$	Junction-to-ambient thermal resistance	179.1	168.3	°C/W
$R_{\theta JC(top)}$	Junction-to-case (top) thermal resistance	62.6	73.8	°C/W
$R_{\theta JB}$	Junction-to-board thermal resistance	107.7	28.1	°C/W
Ψ_{JT}	Junction-to-top characterization parameter	7.0	2.5	°C/W
Ψ_{JB}	Junction-to-board characterization parameter	106.0	27.6	°C/W
$R_{\theta JC(bot)}$	Junction-to-case (bottom) thermal resistance	N/A	N/A	°C/W

(1) For more information about traditional and new thermal metrics, see the [Semiconductor and IC Package Thermal Metrics](#) application report.

6.5 Electrical Characteristics

at $T_A = -40^\circ\text{C}$ to $+125^\circ\text{C}$, $V_+ = 5\text{ V}$, $V_{IN+} = 12\text{ V}$, and $R_L = 125\text{ k}\Omega$ (unless otherwise noted)

PARAMETER	TEST CONDITIONS	INA138-Q1			INA168-Q1			UNIT
		MIN	TYP	MAX	MIN	TYP	MAX	
INPUT								
Full-scale sense voltage	$V_{SENSE} = V_{IN+} - V_{IN-}$		100	500		100	500	mV
Common-mode rejection	$V_{IN+} = 2.7\text{ V}$ to 36 V , $V_{SENSE} = 50\text{ mV}$	100	120					dB
	$V_{IN+} = 2.7\text{ V}$ to 60 V , $V_{SENSE} = 50\text{ mV}$				100	120		
Offset voltage ⁽¹⁾			± 0.2	± 2		± 0.2	± 2	mV
Offset voltage vs temperature			1			1		$\mu\text{V}/^\circ\text{C}$
Offset voltage vs power supply (V_+)	$V_+ = 2.7\text{ V}$ to 36 V , $V_{SENSE} = 50\text{ mV}$		0.1	10				$\mu\text{V}/\text{V}$
	$V_+ = 2.7\text{ V}$ to 60 V , $V_{SENSE} = 50\text{ mV}$					0.1	10	
Input bias current	$V_{IN+} = V_{IN-} = 12\text{ V}$			10			10	μA
OUTPUT								
Transconductance	$V_{SENSE} = 10\text{ mV}$ to 150 mV		194	206		194	206	$\mu\text{A}/\text{V}$
Transconductance versus temperature	$V_{SENSE} = 100\text{ mV}$			10			10	$\text{nA}/^\circ\text{C}$
Nonlinearity error	$V_{SENSE} = 10\text{ mV}$ to 150 mV		$\pm 0.01\%$	$\pm 0.2\%$		$\pm 0.01\%$	$\pm 0.2\%$	
Total output error	$V_{SENSE} = 100\text{ mV}$		$\pm 0.5\%$	$\pm 3.2\%$		$\pm 0.5\%$	$\pm 3.2\%$	
Output impedance			1 5			1 5		$\text{G}\Omega$ pF
Voltage output swing to power supply (V_+)			$(V_+) - 0.8$	$(V_+) - 1.2$		$(V_+) - 0.8$	$(V_+) - 1.2$	V
Voltage output swing to common mode, V_{CM}			$V_{CM} - 0.5$	$V_{CM} - 1.2$		$V_{CM} - 0.5$	$V_{CM} - 1.2$	V
FREQUENCY RESPONSE								
Bandwidth	$R_L = 5\text{ k}\Omega$			800			800	kHz
	$R_L = 125\text{ k}\Omega$			32			32	
Settling time (0.1%)	5-V step, $R_L = 5\text{ k}\Omega$			1.8			1.8	μs
	5-V step, $R_L = 125\text{ k}\Omega$			30			30	
NOISE								
Output-current noise density	$T_A = 25^\circ\text{C}$			9			9	$\text{pA}/\sqrt{\text{Hz}}$
Total output-current noise	$\text{BW} = 100\text{ kHz}$			3			3	nA RMS
POWER SUPPLY								
Quiescent current	$V_{SENSE} = 0\text{ V}$, $I_O = 0\text{ mA}$			25		60	25	60

(1) Defined as the amount of input voltage, V_{SENSE} , to drive the output to zero.

6.6 Typical Characteristics

at $T_A = 25^\circ\text{C}$, $V_+ = 5\text{ V}$, $V_{IN+} = 12\text{ V}$, and $R_L = 125\text{ k}\Omega$ (unless otherwise noted)

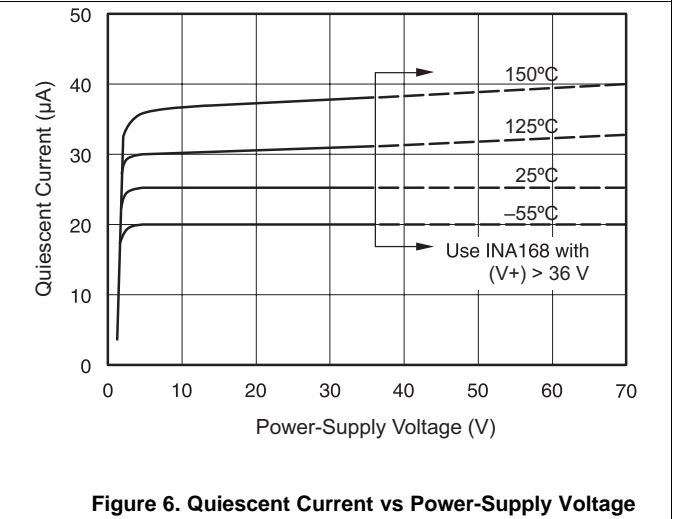
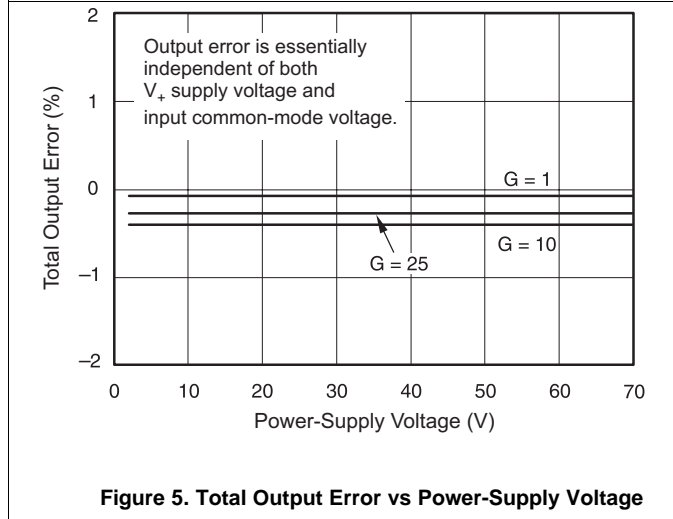
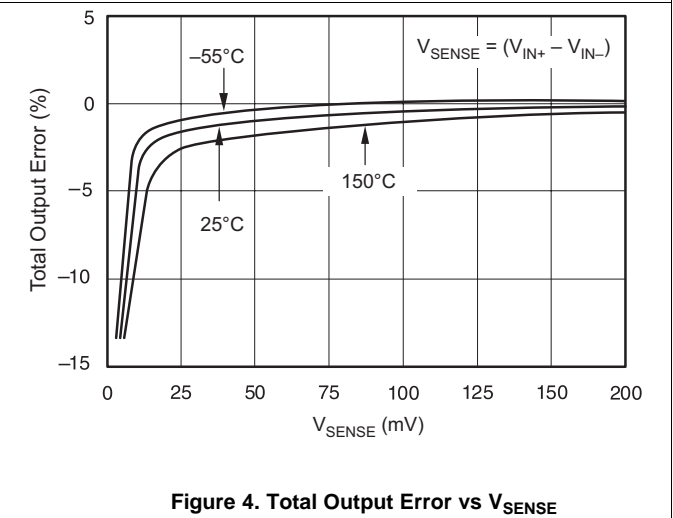
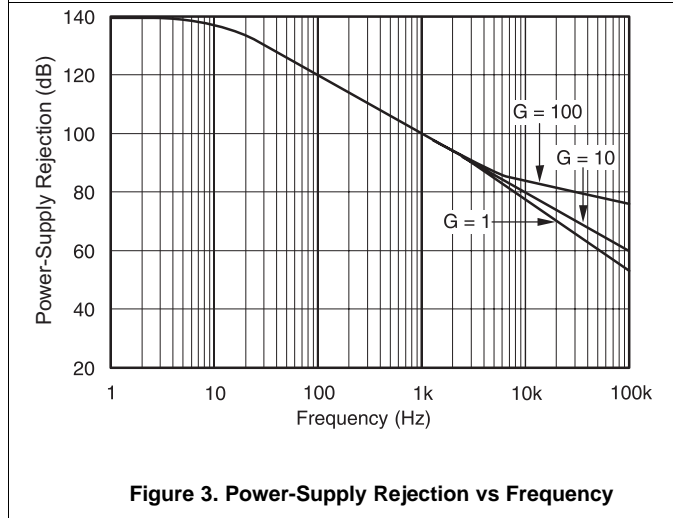
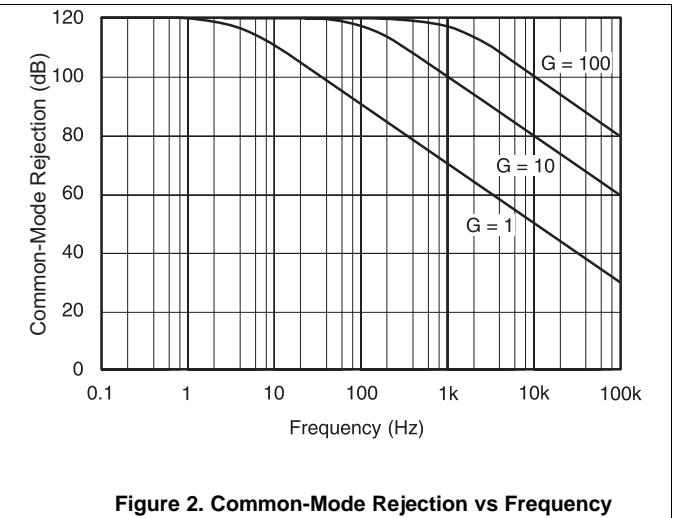
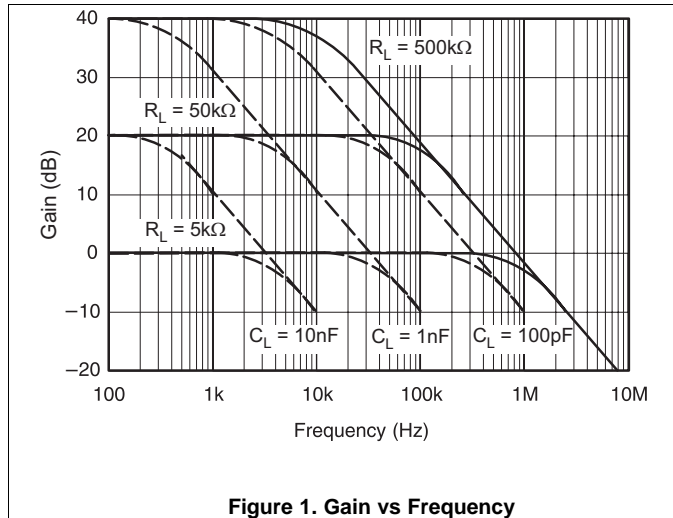

Typical Characteristics (continued)

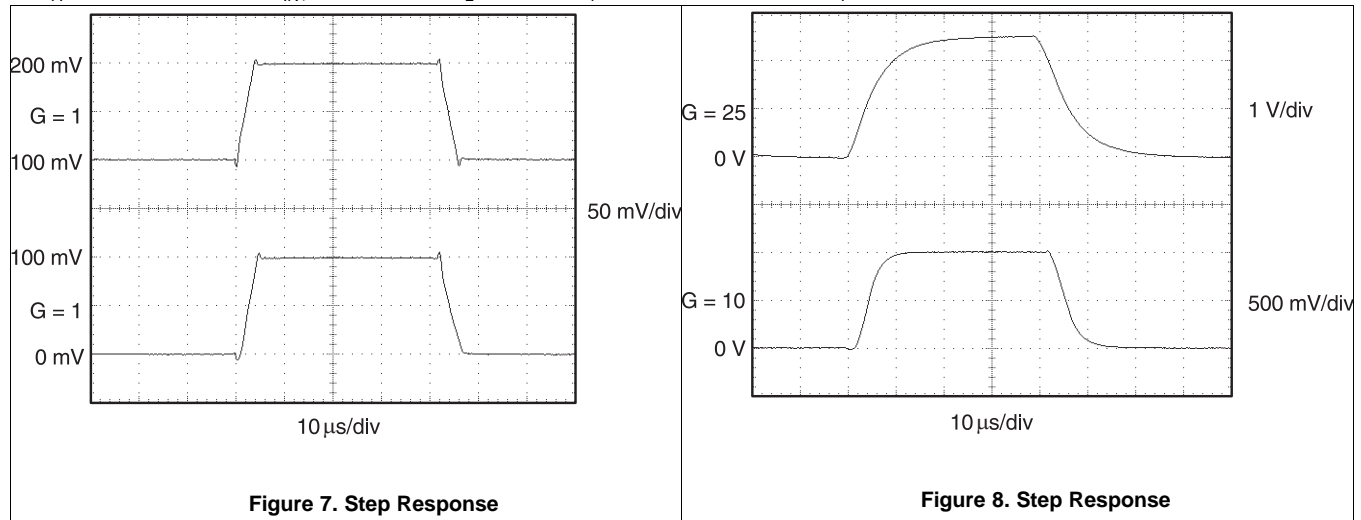
 at $T_A = 25^\circ\text{C}$, $V_+ = 5\text{ V}$, $V_{IN+} = 12\text{ V}$, and $R_L = 125\text{ k}\Omega$ (unless otherwise noted)

7 Detailed Description

7.1 Overview

The INA138-Q1 and INA168-Q1 devices (INA1x8-Q1) are comprised of a high-voltage, precision operational amplifier, precision thin film resistors trimmed in production to an absolute tolerance, and a low-noise output transistor. The INA1x8-Q1 are powered from a single power supply, and the input voltages can exceed the power supply voltage. The INA1x8-Q1 are ideal for measuring small differential voltages, such as those generated across a shunt resistor, in the presence of large common-mode voltages. The [Functional Block Diagram](#) shows the functional components within both the INA138-Q1 and INA168-Q1 devices.

7.2 Functional Block Diagram

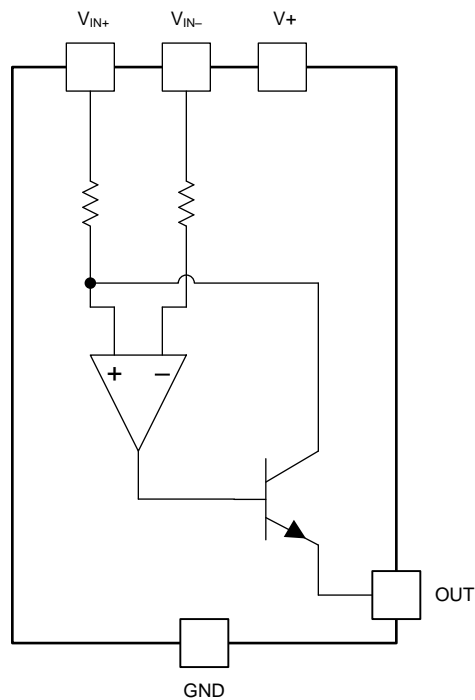

7.3 Feature Description

7.3.1 Output Voltage Range

The output of the INA1x8-Q1 is a current that is converted to a voltage by the load resistor, R_L . The output current remains accurate within the compliance voltage range of the output circuitry. The shunt voltage and the input common-mode and power-supply voltages limit the maximum possible output swing. The maximum output voltage ($V_{out\ max}$) compliance is limited by either [Equation 1](#) or [Equation 2](#), whichever is lower:

$$V_{out\ max} = (V+) - 0.7\ V - (V_{IN+} - V_{IN-}) \quad (1)$$

or

$$V_{out\ max} = V_{IN-} - 0.5\ V \quad (2)$$

7.3.2 Bandwidth

Measurement bandwidth is affected by the value of the load resistor, R_L . High gain produced by high values of R_L yields a narrower measurement bandwidth (see the [Typical Characteristics](#) section). For the widest possible bandwidth, keep the capacitive load on the output to a minimum. Reduction in bandwidth due to capacitive load is shown in the [Typical Characteristics](#) section.

If bandwidth limiting (filtering) is desired, add a capacitor to the output (see [Figure 12](#)). This capacitor does not cause instability.

7.4 Device Functional Modes

For proper operation, the INA1x8-Q1 must operate within the specified limits. Operating either device outside of their specified power-supply voltage range, or their specified common-mode range, results in unexpected behavior, and is not recommended. Additionally, operating the output beyond the specified limits with respect to power-supply voltage and input common-mode voltage also produces unexpected results. See the [Electrical Characteristics](#) section for the device specifications.

8 Application and Implementation

NOTE

Information in the following applications sections is not part of the TI component specification, and TI does not warrant its accuracy or completeness. TI's customers are responsible for determining suitability of components for their purposes. Customers should validate and test their design implementation to confirm system functionality.

8.1 Application Information

8.1.1 Operation

[Figure 9](#) illustrates the basic circuit diagram for both the INA138-Q1 and INA168-Q1. Load current I_S is drawn from supply V_P through shunt resistor R_S . The voltage drop in the shunt resistor is forced across R_{G1} by the internal op amp, causing current to flow into the collector of Q1. External resistor R_L converts the output current, I_O , to a voltage, V_{OUT} , at the OUT pin. The transfer function for the INA1x8-Q1 is shown in [Equation 3](#):

$$I_O = g_m (V_{IN+} - V_{IN-})$$

where

- $g_m = 200\ \mu A/V$ (3)

In the circuit of [Figure 9](#), the input voltage, $(V_{IN+} - V_{IN-})$, is equal to $I_S \times R_S$. The output voltage, V_{OUT} , is equal to $I_O \times R_L$. The transconductance, g_m , of the INA1x8-Q1 is $200\ \mu A/V$. The complete transfer function for the current measurement amplifier in this application is shown in [Equation 4](#):

$$V_{OUT} = (I_S) (R_S) (200\ \mu A/V) (R_L) \quad (4)$$

The maximum differential input voltage for accurate measurements is 0.5 V, producing a 100- μA output current. A differential input voltage of up to 2 V does not cause damage. Differential measurements (V_{IN+} and V_{IN-} pins) must be unipolar, with a more-positive voltage applied to the V_{IN+} pin. If a more-negative voltage is applied to the V_{IN+} pin, I_O goes to zero, but no damage occurs.

Application Information (continued)

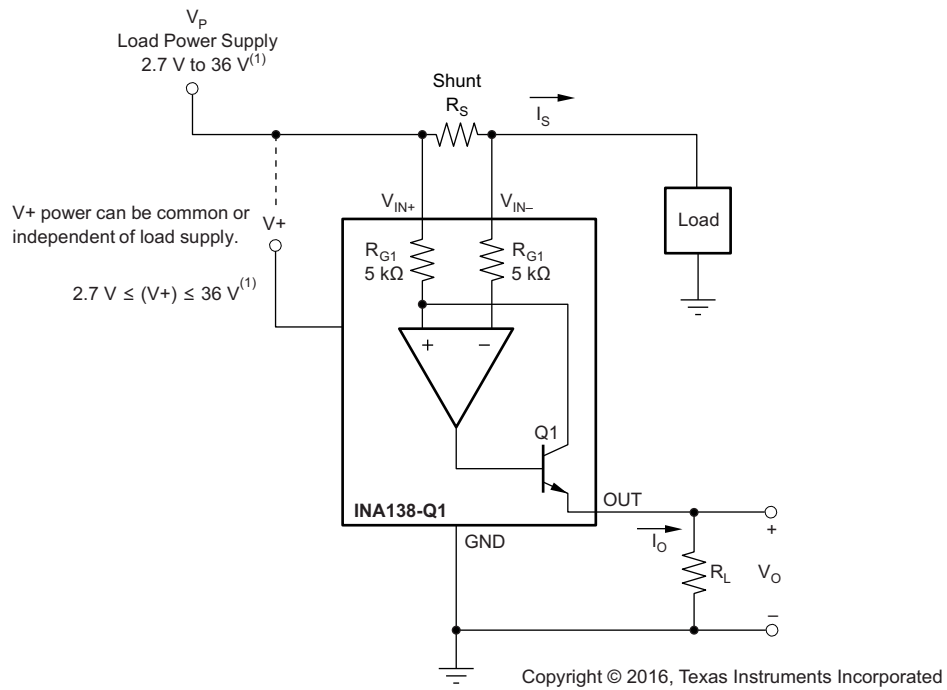

(1) Maximum V_P and V_+ voltage is 60 V with INA168-Q1.

Figure 9. Basic Circuit Connections

Table 1. Voltage Gains and Corresponding Load-Resistor Values

VOLTAGE GAIN	EXACT R_L (k Ω)	NEAREST 1% R_L (k Ω)
1	5	4.99
2	10	10
5	25	24.9
10	50	49.9
20	100	100
50	250	249
100	500	499

8.2 Typical Applications

The INA1x8-Q1 are designed for current-shunt measurement circuits (see [Figure 9](#)) but its basic function is useful in a wide range of circuitry. With a little creativity, many unforeseen uses can be found in measurement and level-shifting circuits. A few ideas are illustrated in the following subsections.

8.2.1 Buffering Output to Drive an ADC

Digitize the output of the INA138-Q1 or INA168-Q1 devices using a 1-MSPS analog-to-digital converter (ADC).

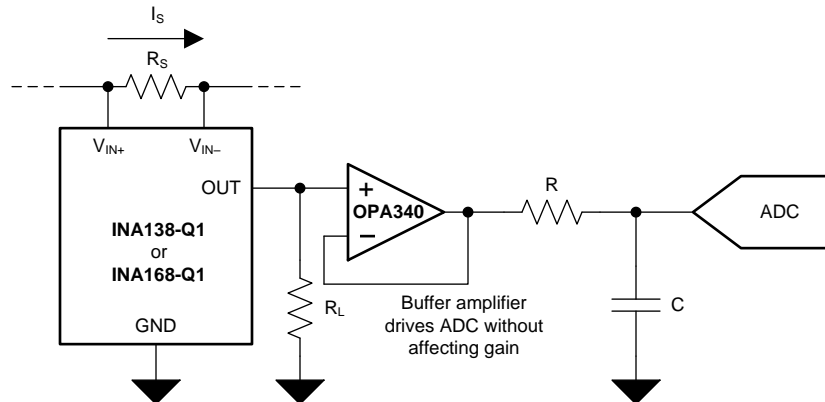

Figure 10. Buffering Output to Drive an ADC

8.2.1.1 Design Requirements

For this design example, use the input parameters shown in [Table 2](#).

Table 2. Design Parameters

DESIGN PARAMETER	EXAMPLE VALUE
Supply voltage, V+	5 V
Common-mode voltage, V _{CM}	INA138-Q1: 2.7 V to 36 V
	INA168-Q1: 2.7 V to 60 V
Full-scale shunt voltage, V _{SENSE}	50 mV to 100 mV
Load resistor, R _L	5 kΩ to 500 kΩ

8.2.1.2 Detailed Design Procedure

8.2.1.2.1 Selecting R_S and R_L

In [Figure 10](#), the value chosen for the shunt resistor, R_S, depends on the application and is a compromise between small-signal accuracy and maximum permissible voltage loss in the measurement line. High values of R_S provide better accuracy at lower currents by minimizing the effects of offset, while low values of R_S minimize voltage loss in the supply line. For most applications, best performance is attained with an R_S value that provides a full-scale shunt voltage range of 50 mV to 100 mV. Maximum input voltage for accurate measurements is 500 mV.

Choose an R_L that provides the desired full-scale output voltage. The output impedance of the INA1x8-Q1 OUT pin is very high, permitting the use of R_L values up to 500 kΩ with excellent accuracy. The input impedance of any additional circuitry at the output must be much higher than the value of R_L to avoid degrading accuracy.

Some ADCs have input impedances that significantly affects measurement gain. The input impedance of the ADC can be included as part of the effective R_L if the ADC input can be modeled as a resistor to ground. Alternatively, an op amp can be used to buffer the ADC input, as shown in [Figure 10](#). The INA1x8-Q1 are current output devices, and as such, have an inherently large output impedance. The output currents from the amplifier are converted to an output voltage using the load resistor, R_L, connected from the amplifier output to ground. The ratio of the load resistor value to that of the internal resistor value determines the voltage gain of the system.

In many applications, digitizing the output of the INA1x8-Q1 is required. Digitizing is accomplished by connecting the output of the amplifier to an ADC. It is very common for an ADC to have a dynamic input impedance. If the INA1x8-Q1 output is connected directly to an ADC input, the input impedance of the ADC is effectively connected in parallel with gain setting resistor R_L . This parallel impedance combination affects the gain of the system and the impact on the gain is difficult to estimate accurately. A simple solution that eliminates the paralleling of impedances, and simplifies the gain of the circuit is to place a buffer amplifier, such as the [OPA340](#), between the output of the INA1x8-Q1 and the input to the ADC.

[Figure 10](#) illustrates this concept. Notice that a low-pass filter is placed between the OPA340 output and the input to the ADC. The filter capacitor is required to provide any instantaneous demand for current required by the input stage of the ADC. The filter resistor is required to isolate the OPA340 output from the filter capacitor in order to maintain circuit stability. The values for the filter components vary according to the operational amplifier used for the buffer and the particular ADC selected. More information regarding the design of the low-pass filter is found in the TI Precision Design, [16 bit 1MSPS Data Acquisition Reference Design for Single-Ended Multiplexed Applications](#).

[Figure 11](#) shows the expected results when driving an ADC at 1 MSPS with and without buffering the INA1x8-Q1 output. Without the buffer, the high impedance of the INA1x8-Q1 reacts with the input capacitance and sample-and-hold capacitance of the ADC, and does not allow the sampled value to reach the correct final value before the ADC is reset, and the next conversion starts. Adding the buffer amplifier significantly reduces the output impedance driving the sample-and-hold circuitry, and allows for higher conversion rates.

8.2.1.3 Application Curve

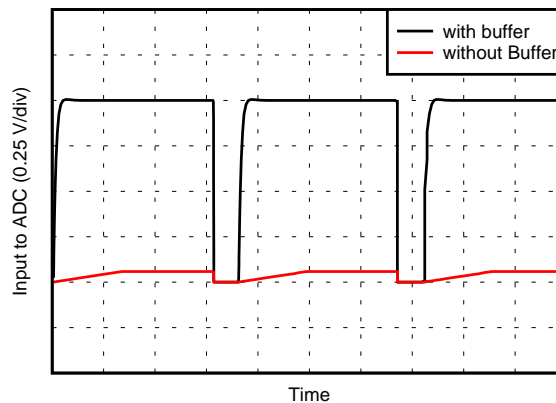

Figure 11. Driving an ADC With and Without a Buffer

8.2.2 Output Filter

Filter the output of the INA1x8-Q1 devices.

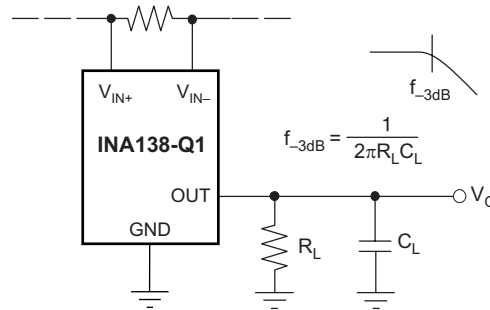

Figure 12. Output Filter

8.2.2.1 Design Requirements

For this design example, use the input parameters shown in Table 3.

Table 3. Design Parameters

DESIGN PARAMETER	EXAMPLE VALUE
Supply voltage, V+	INA138-Q1: 2.7 V to 36 V
	INA168-Q1: 2.7 V to 60 V
Common-mode voltage, V _{CM}	INA138-Q1: 2.7 V to 36 V
	INA168-Q1: 2.7 V to 60 V
Full-scale shunt voltage, V _{SENSE}	50 mV to 100 mV
Load resistor, R _L	5 kΩ to 500 kΩ

8.2.2.2 Detailed Design Procedure

A low-pass filter can be formed at the output of the INA1x8-Q1 simply by placing a capacitor of the desired value in parallel with the load resistor. First, determine the value of the load resistor needed to achieve the desired gain by using Table 1. Next, determine the capacitor value that results in the desired cutoff frequency according to the equation shown in Figure 12. Figure 13 shows various combinations of gain settings (determined by R_L) and filter capacitors.

8.2.2.3 Application Curve

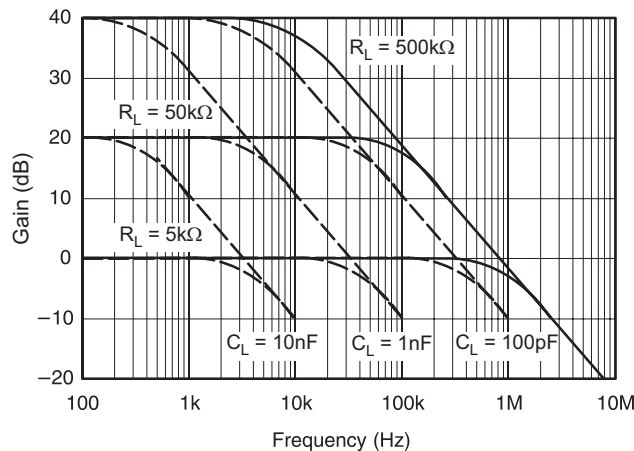
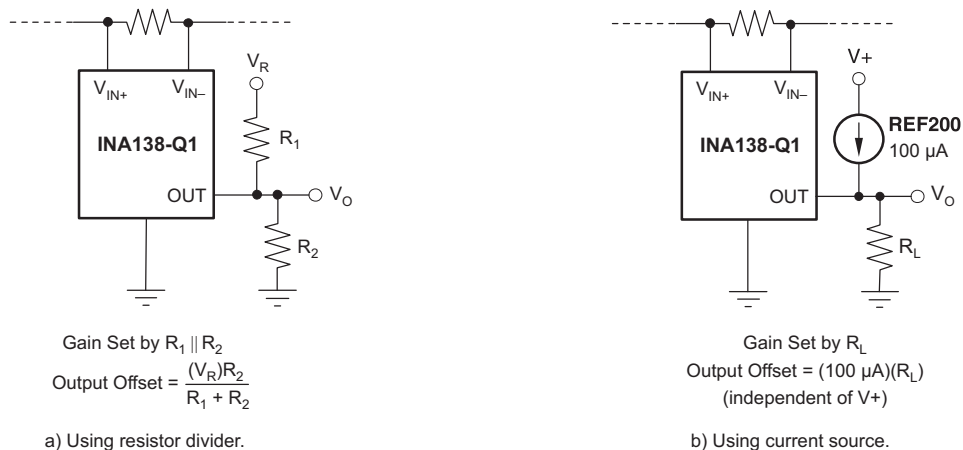

Figure 13. Gain vs Frequency

8.2.3 Offsetting the Output Voltage

For many applications using only a single power supply, the output voltage may have to be level shifted away from ground when there is no load current flowing in the shunt resistor. Level shifting the output of the INA1x8-Q1 is easily accomplished by one of two simple methods shown in Figure 14. Method (a) on the left-hand side of Figure 14 shows a simple voltage-divider method. This method is useful for applications that require the output of the INA1x8-Q1 to remain centered with respect to the power supply at zero load current through the shunt resistor. Using this method, the gain is determined by the parallel combination of R_1 and R_2 , while the output offset is determined by the voltage divider ratio of R_1 and R_2 , as shown in Figure 14(a). For applications that require a fixed value of output offset independent of the power-supply voltage, use current-source method (b) shown on the right-hand side of Figure 14. With this method, a REF200 constant current source is used to generate a constant output offset. Using this method, the gain is determined by R_L , and the offset is determined by the product of the value of the current source and R_L .



Copyright © 2016, Texas Instruments Incorporated

Figure 14. Offsetting the Output Voltage

8.2.4 Bipolar Current Measurement

Configure the INA1x8-Q1 as illustrated in Figure 15 for applications where bidirectional current measurement is required. Two INA1x8-Q1 devices are required; connect the inputs across the shunt resistor; see Figure 15. A comparator, such as the TLV3201, is used to detect the polarity of the load current. The magnitude of the load current is monitored across the resistor connected between ground and the connection labeled *Output*. In this example, the 100-k Ω resistor results in a gain of 20 V/V. The 10-k Ω resistors connected in series with the INA1x8-Q1 output current are used to develop a voltage across the comparator inputs. Two diodes are required to prevent current flow into the INA1x8-Q1 output because only one device at a time provides current to the *Output* connection of the circuit. The circuit functionality is illustrated in Figure 16.

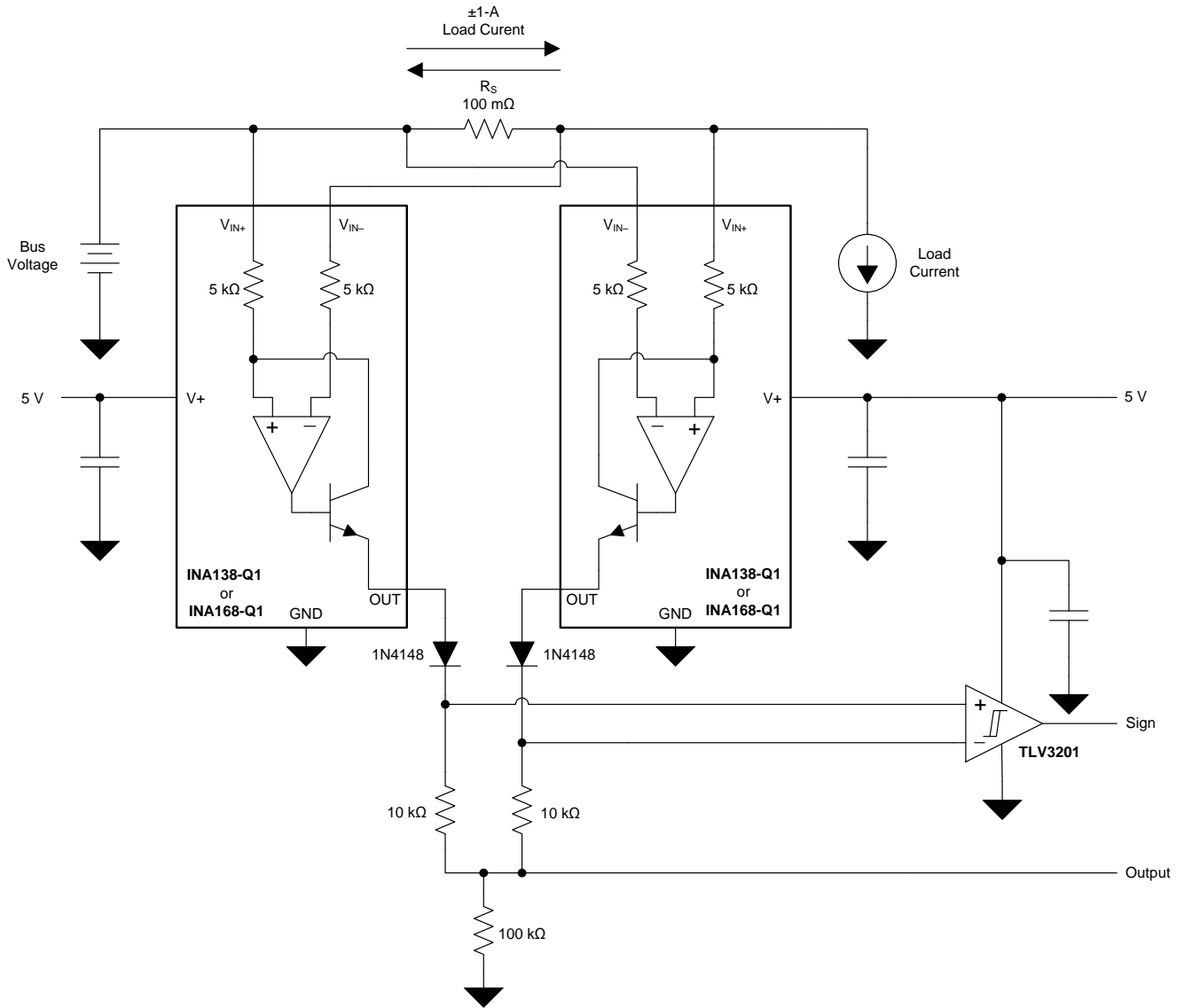

Figure 15. Bipolar Current Measurement

8.2.4.1 Application Curve

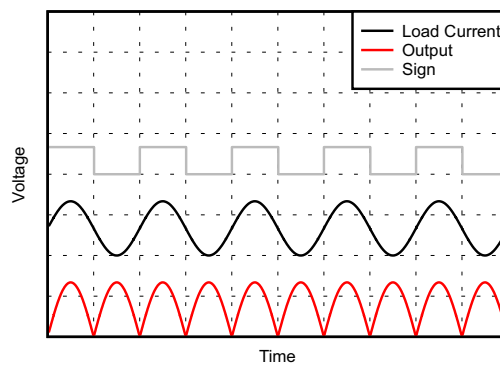

Figure 16. Bipolar Current Measurements Results (Arbitrary Scale)

8.2.5 Bipolar Current Measurement Using Differential Input of an ADC

Use the INA1x8-Q1 with an ADC such as the [ADS7870](#) programmed for differential-mode operation; [Figure 17](#) shows this configuration. In this configuration, the use of two INA138-Q1s or INA168-Q1s allows for bidirectional current measurement. Depending on the polarity of the current, one of the INA devices provides an output voltage, while the other INA device output is zero. In this way, the ADC reads the polarity of current directly, without the need for additional circuitry.

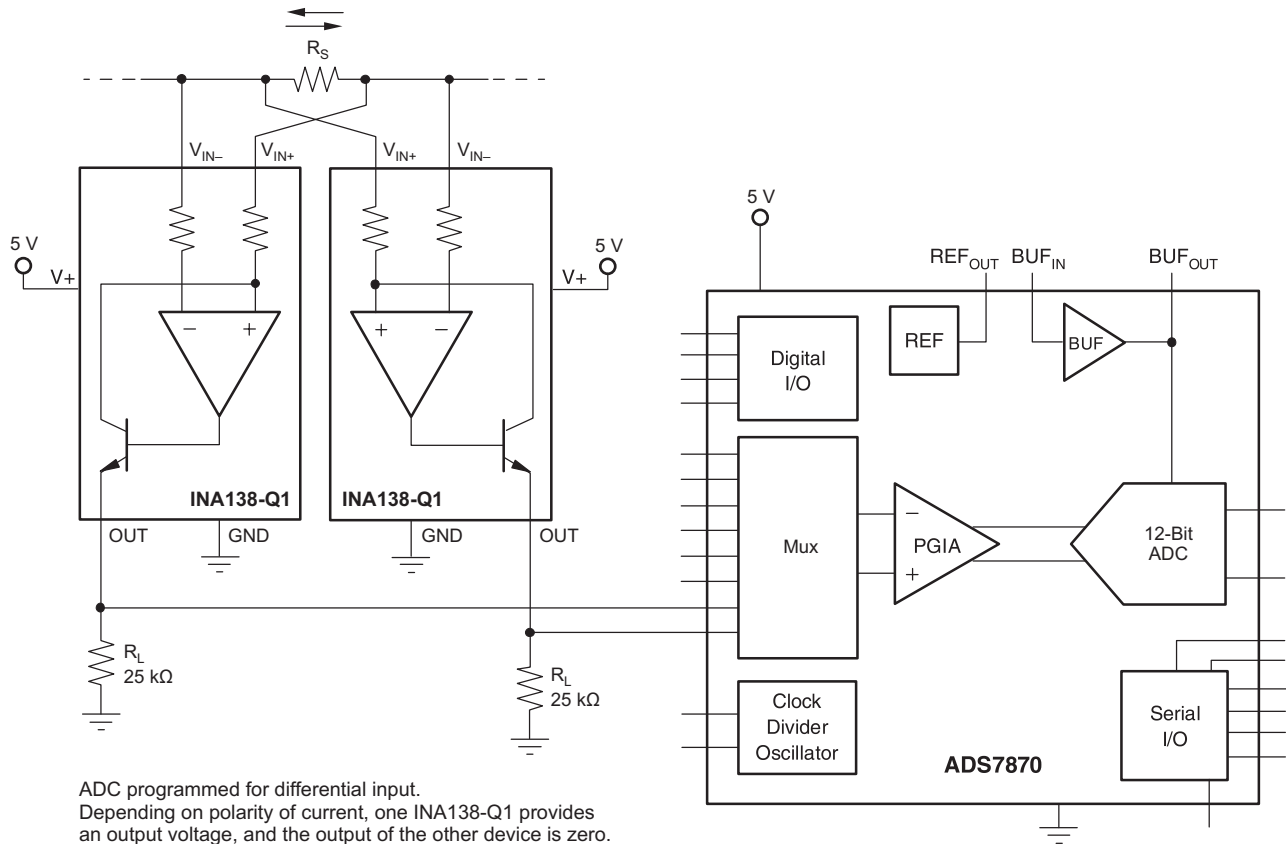
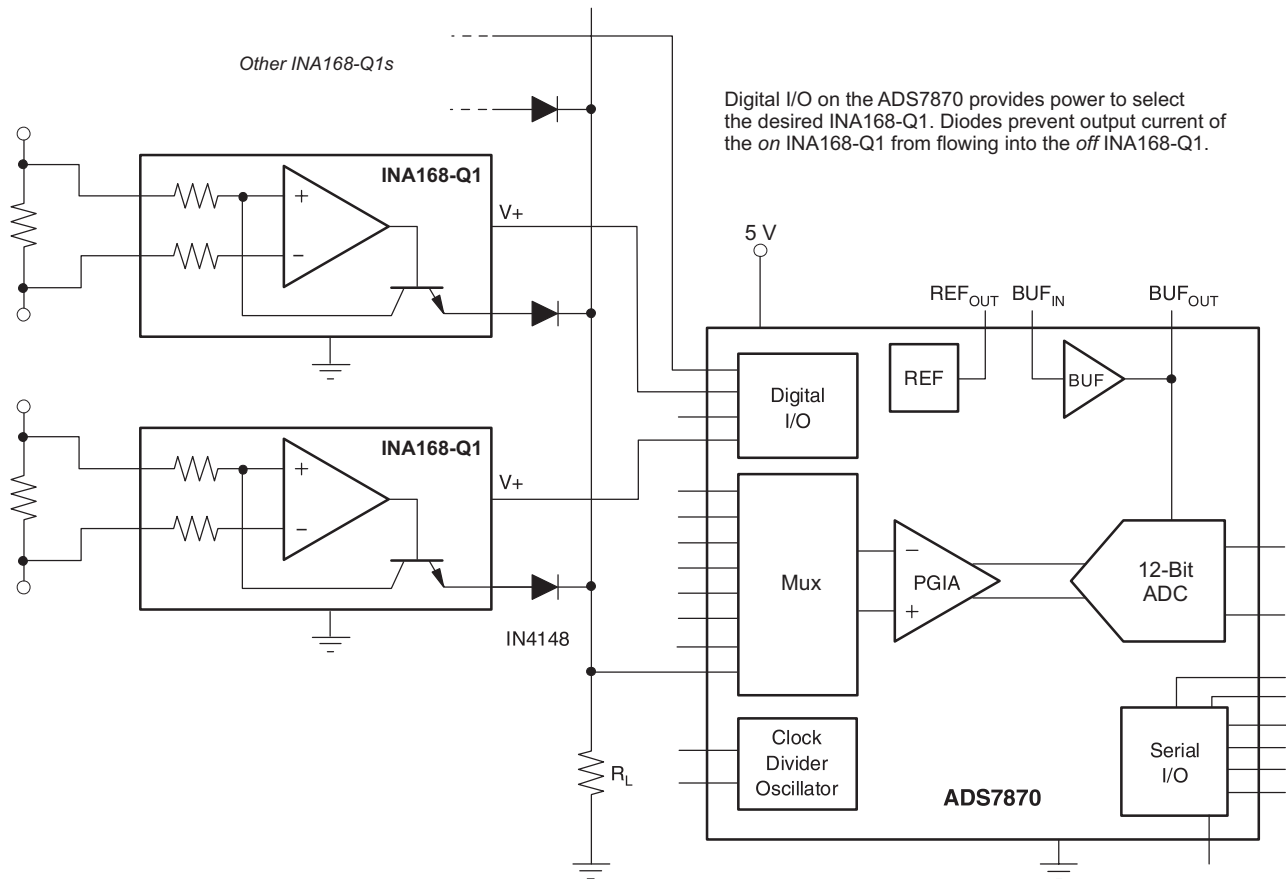

Figure 17. Bipolar Current Measurement Using Differential Input of the ADC

8.2.6 Multiplexed Measurement Using Logic Signal for Power

Measure multiple loads as shown in [Figure 18](#). In this configuration, each INA138-Q1 or INA168-Q1 device is powered by the digital I/O from the [ADS7870](#). Multiplexing is achieved by switching on or off each desired I/O.



Copyright © 2016, Texas Instruments Incorporated

Figure 18. Multiplexed Measurement Using Logic Signal for Power

9 Power Supply Recommendations

The input circuitry of the INA1x8-Q1 can accurately measure beyond the power-supply voltage, $V+$. For example, the $V+$ power supply can be 5 V, whereas the load power-supply voltage goes up to 36 V with the INA138-Q1, or 60 V with the INA168-Q1. However, the output voltage range of the OUT pin is limited by the lesser of the two voltages (see the [Output Voltage Range](#) section). Place a 0.1- μF capacitor near the power-supply pin on the INA1x8-Q1. Additional capacitance may be required for applications with noisy power-supply voltages.

10 Layout

10.1 Layout Guidelines

Figure 19 shows the basic connection of the INA1x8-Q1 in the TSSOP-8 package. Connect input pins $V_{\text{IN}+}$ and $V_{\text{IN}-}$ as closely as possible to the shunt resistor to minimize any resistance in series with the shunt resistance. Output resistor R_L is shown connected between the OUT pin and ground. Best accuracy is achieved with the output voltage measured directly across R_L . Measuring directly across R_L is especially important in high-current systems where load current could flow in the ground connections and affect measurement accuracy.

No power-supply bypass capacitors are required for stability of the INA1x8-Q1. However, applications with noisy or high-impedance power supplies may require decoupling capacitors to reject power-supply noise. Connect bypass capacitors close to the device pins.

10.2 Layout Example

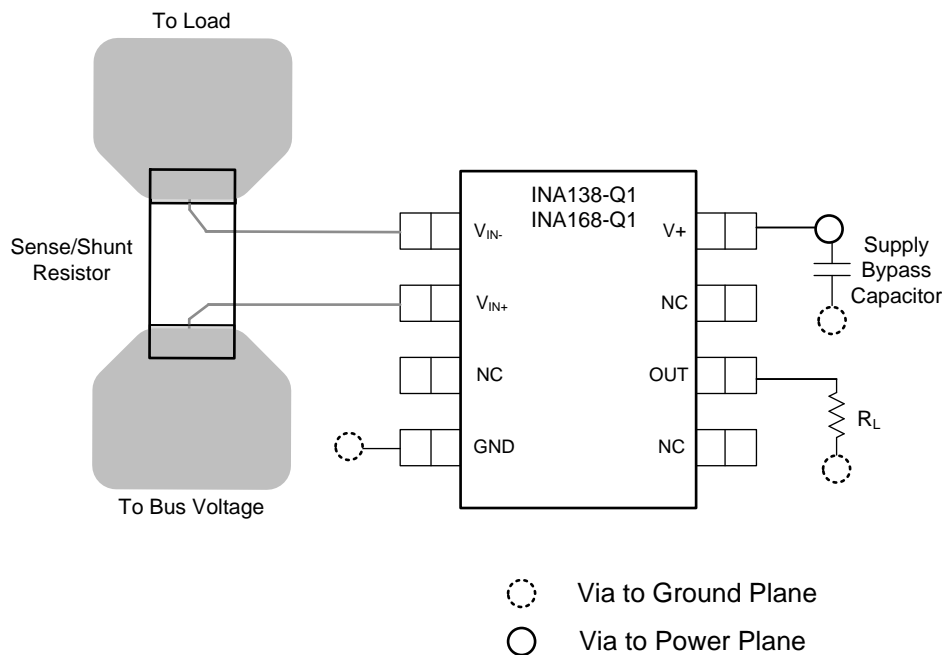

Figure 19. Typical Layout Example

11 Device and Documentation Support

11.1 Documentation Support

11.1.1 Related Documentation

For related documentation see the following:

[16 bit 1MSPS Data Acquisition Reference Design for Single-Ended Multiplexed Applications TI Precision Design](#)

11.2 Related Links

Table 4 lists quick access links. Categories include technical documents, support and community resources, tools and software, and quick access to order now.

Table 4. Related Links

PARTS	PRODUCT FOLDER	ORDER NOW	TECHNICAL DOCUMENTS	TOOLS & SOFTWARE	SUPPORT & COMMUNITY
INA138-Q1	Click here	Click here	Click here	Click here	Click here
INA168-Q1	Click here	Click here	Click here	Click here	Click here

11.3 Receiving Notification of Documentation Updates

To receive notification of documentation updates, navigate to the device product folder on ti.com. In the upper right corner, click on *Alert me* to register and receive a weekly digest of any product information that has changed. For change details, review the revision history included in any revised document.

11.4 Community Resources

The following links connect to TI community resources. Linked contents are provided "AS IS" by the respective contributors. They do not constitute TI specifications and do not necessarily reflect TI's views; see TI's [Terms of Use](#).

TI E2E™ Online Community *TI's Engineer-to-Engineer (E2E) Community*. Created to foster collaboration among engineers. At e2e.ti.com, you can ask questions, share knowledge, explore ideas and help solve problems with fellow engineers.

Design Support *TI's Design Support* Quickly find helpful E2E forums along with design support tools and contact information for technical support.

11.5 Trademarks

E2E is a trademark of Texas Instruments.
All other trademarks are the property of their respective owners.

11.6 Electrostatic Discharge Caution



This integrated circuit can be damaged by ESD. Texas Instruments recommends that all integrated circuits be handled with appropriate precautions. Failure to observe proper handling and installation procedures can cause damage.

ESD damage can range from subtle performance degradation to complete device failure. Precision integrated circuits may be more susceptible to damage because very small parametric changes could cause the device not to meet its published specifications.

11.7 Glossary

SLYZ022 — *TI Glossary*.

This glossary lists and explains terms, acronyms, and definitions.

12 Mechanical, Packaging, and Orderable Information

The following pages include mechanical, packaging, and orderable information. This information is the most current data available for the designated devices. This data is subject to change without notice and revision of this document. For browser-based versions of this data sheet, refer to the left-hand navigation.

PACKAGING INFORMATION

Orderable Device	Status (1)	Package Type	Package Drawing	Pins	Package Qty	Eco Plan (2)	Lead finish/ Ball material (6)	MSL Peak Temp (3)	Op Temp (°C)	Device Marking (4/5)	Samples
INA138QPWRQ1	ACTIVE	TSSOP	PW	8	2000	RoHS & Green	NIPDAU	Level-2-260C-1 YEAR	-40 to 125	INA138	Samples
INA168QDBVRQ1	ACTIVE	SOT-23	DBV	5	3000	RoHS & Green	NIPDAU	Level-2-260C-1 YEAR	-40 to 125	LUIQ	Samples
INA168QPWRQ1	ACTIVE	TSSOP	PW	8	2000	RoHS & Green	NIPDAU	Level-1-260C-UNLIM	-40 to 125	INA168	Samples

(1) The marketing status values are defined as follows:

ACTIVE: Product device recommended for new designs.

LIFEBUY: TI has announced that the device will be discontinued, and a lifetime-buy period is in effect.

NRND: Not recommended for new designs. Device is in production to support existing customers, but TI does not recommend using this part in a new design.

PREVIEW: Device has been announced but is not in production. Samples may or may not be available.

OBSELETE: TI has discontinued the production of the device.

(2) **RoHS:** TI defines "RoHS" to mean semiconductor products that are compliant with the current EU RoHS requirements for all 10 RoHS substances, including the requirement that RoHS substance do not exceed 0.1% by weight in homogeneous materials. Where designed to be soldered at high temperatures, "RoHS" products are suitable for use in specified lead-free processes. TI may reference these types of products as "Pb-Free".

RoHS Exempt: TI defines "RoHS Exempt" to mean products that contain lead but are compliant with EU RoHS pursuant to a specific EU RoHS exemption.

Green: TI defines "Green" to mean the content of Chlorine (Cl) and Bromine (Br) based flame retardants meet JS709B low halogen requirements of <=1000ppm threshold. Antimony trioxide based flame retardants must also meet the <=1000ppm threshold requirement.

(3) MSL, Peak Temp. - The Moisture Sensitivity Level rating according to the JEDEC industry standard classifications, and peak solder temperature.

(4) There may be additional marking, which relates to the logo, the lot trace code information, or the environmental category on the device.

(5) Multiple Device Markings will be inside parentheses. Only one Device Marking contained in parentheses and separated by a "~" will appear on a device. If a line is indented then it is a continuation of the previous line and the two combined represent the entire Device Marking for that device.

(6) Lead finish/Ball material - Orderable Devices may have multiple material finish options. Finish options are separated by a vertical ruled line. Lead finish/Ball material values may wrap to two lines if the finish value exceeds the maximum column width.

Important Information and Disclaimer:The information provided on this page represents TI's knowledge and belief as of the date that it is provided. TI bases its knowledge and belief on information provided by third parties, and makes no representation or warranty as to the accuracy of such information. Efforts are underway to better integrate information from third parties. TI has taken and continues to take reasonable steps to provide representative and accurate information but may not have conducted destructive testing or chemical analysis on incoming materials and chemicals. TI and TI suppliers consider certain information to be proprietary, and thus CAS numbers and other limited information may not be available for release.

In no event shall TI's liability arising out of such information exceed the total purchase price of the TI part(s) at issue in this document sold by TI to Customer on an annual basis.

OTHER QUALIFIED VERSIONS OF INA138-Q1, INA168-Q1 :

- Catalog: [INA138](#), [INA168](#)

NOTE: Qualified Version Definitions:

- Catalog - TI's standard catalog product

TAPE AND REEL INFORMATION



QUADRANT ASSIGNMENTS FOR PIN 1 ORIENTATION IN TAPE



*All dimensions are nominal

Device	Package Type	Package Drawing	Pins	SPQ	Reel Diameter (mm)	Reel Width W1 (mm)	A0 (mm)	B0 (mm)	K0 (mm)	P1 (mm)	W (mm)	Pin1 Quadrant
INA138QPWRQ1	TSSOP	PW	8	2000	330.0	12.4	7.0	3.6	1.6	8.0	12.0	Q1
INA168QDBVRQ1	SOT-23	DBV	5	3000	180.0	8.4	3.15	3.1	1.55	4.0	8.0	Q3
INA168QPWRQ1	TSSOP	PW	8	2000	330.0	12.4	7.0	3.6	1.6	8.0	12.0	Q1

TAPE AND REEL BOX DIMENSIONS



*All dimensions are nominal

Device	Package Type	Package Drawing	Pins	SPQ	Length (mm)	Width (mm)	Height (mm)
INA138QPWRQ1	TSSOP	PW	8	2000	367.0	367.0	35.0
INA168QDBVRQ1	SOT-23	DBV	5	3000	210.0	185.0	35.0
INA168QPWRQ1	TSSOP	PW	8	2000	367.0	367.0	35.0

EXAMPLE BOARD LAYOUT

DBV0005A

SOT-23 - 1.45 mm max height

SMALL OUTLINE TRANSISTOR



LAND PATTERN EXAMPLE
EXPOSED METAL SHOWN
SCALE:15X



SOLDER MASK DETAILS

4214839/J 02/2024

NOTES: (continued)

- 6. Publication IPC-7351 may have alternate designs.
- 7. Solder mask tolerances between and around signal pads can vary based on board fabrication site.

EXAMPLE STENCIL DESIGN

DBV0005A

SOT-23 - 1.45 mm max height

SMALL OUTLINE TRANSISTOR



SOLDER PASTE EXAMPLE
BASED ON 0.125 mm THICK STENCIL
SCALE:15X

4214839/J 02/2024

NOTES: (continued)

8. Laser cutting apertures with trapezoidal walls and rounded corners may offer better paste release. IPC-7525 may have alternate design recommendations.
9. Board assembly site may have different recommendations for stencil design.

PW0008A



PACKAGE OUTLINE
TSSOP - 1.2 mm max height

SMALL OUTLINE PACKAGE

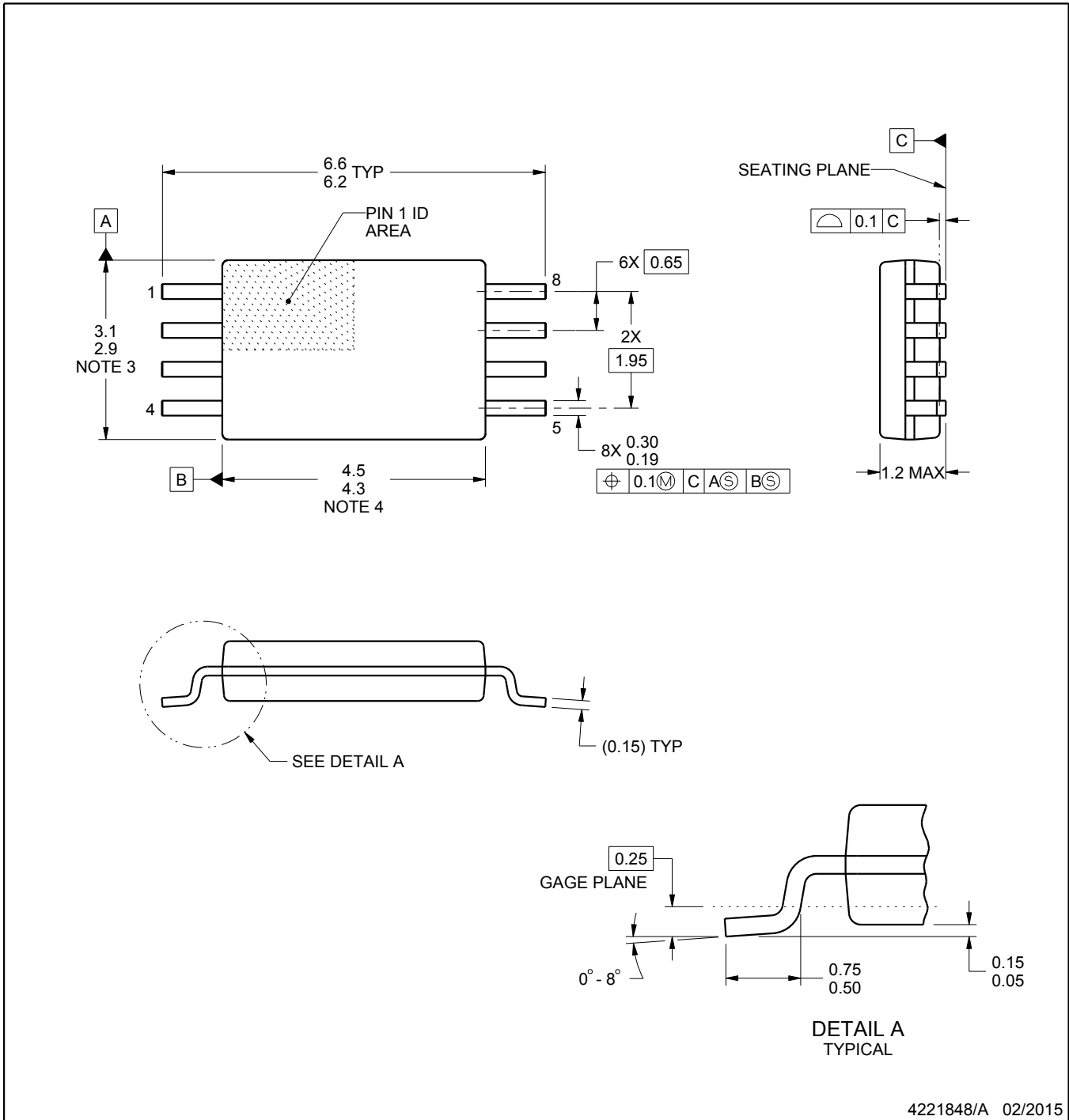

4221848/A 02/2015

NOTES:

1. All linear dimensions are in millimeters. Any dimensions in parenthesis are for reference only. Dimensioning and tolerancing per ASME Y14.5M.
2. This drawing is subject to change without notice.
3. This dimension does not include mold flash, protrusions, or gate burrs. Mold flash, protrusions, or gate burrs shall not exceed 0.15 mm per side.
4. This dimension does not include interlead flash. Interlead flash shall not exceed 0.25 mm per side.
5. Reference JEDEC registration MO-153, variation AA.

EXAMPLE BOARD LAYOUT

PW0008A

TSSOP - 1.2 mm max height

SMALL OUTLINE PACKAGE

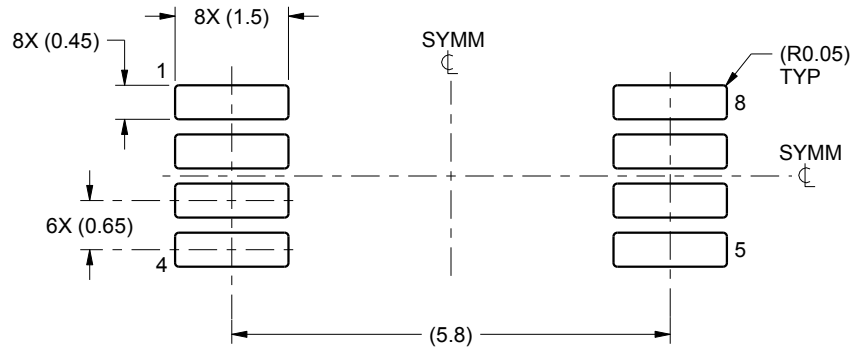

LAND PATTERN EXAMPLE
SCALE:10X



SOLDER MASK DETAILS
NOT TO SCALE

4221848/A 02/2015

NOTES: (continued)

- 6. Publication IPC-7351 may have alternate designs.
- 7. Solder mask tolerances between and around signal pads can vary based on board fabrication site.

EXAMPLE STENCIL DESIGN

PW0008A

TSSOP - 1.2 mm max height

SMALL OUTLINE PACKAGE

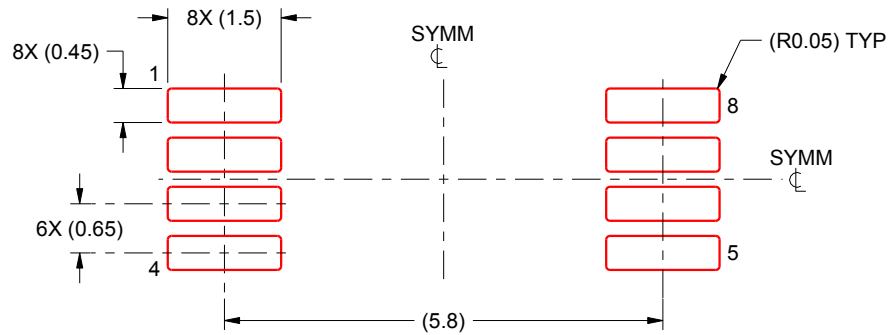

SOLDER PASTE EXAMPLE
BASED ON 0.125 mm THICK STENCIL
SCALE:10X

4221848/A 02/2015

NOTES: (continued)

8. Laser cutting apertures with trapezoidal walls and rounded corners may offer better paste release. IPC-7525 may have alternate design recommendations.
9. Board assembly site may have different recommendations for stencil design.

IMPORTANT NOTICE AND DISCLAIMER

TI PROVIDES TECHNICAL AND RELIABILITY DATA (INCLUDING DATA SHEETS), DESIGN RESOURCES (INCLUDING REFERENCE DESIGNS), APPLICATION OR OTHER DESIGN ADVICE, WEB TOOLS, SAFETY INFORMATION, AND OTHER RESOURCES "AS IS" AND WITH ALL FAULTS, AND DISCLAIMS ALL WARRANTIES, EXPRESS AND IMPLIED, INCLUDING WITHOUT LIMITATION ANY IMPLIED WARRANTIES OF MERCHANTABILITY, FITNESS FOR A PARTICULAR PURPOSE OR NON-INFRINGEMENT OF THIRD PARTY INTELLECTUAL PROPERTY RIGHTS.

These resources are intended for skilled developers designing with TI products. You are solely responsible for (1) selecting the appropriate TI products for your application, (2) designing, validating and testing your application, and (3) ensuring your application meets applicable standards, and any other safety, security, regulatory or other requirements.

These resources are subject to change without notice. TI grants you permission to use these resources only for development of an application that uses the TI products described in the resource. Other reproduction and display of these resources is prohibited. No license is granted to any other TI intellectual property right or to any third party intellectual property right. TI disclaims responsibility for, and you will fully indemnify TI and its representatives against, any claims, damages, costs, losses, and liabilities arising out of your use of these resources.

TI's products are provided subject to [TI's Terms of Sale](#) or other applicable terms available either on [ti.com](https://www.ti.com) or provided in conjunction with such TI products. TI's provision of these resources does not expand or otherwise alter TI's applicable warranties or warranty disclaimers for TI products.

TI objects to and rejects any additional or different terms you may have proposed.

Mailing Address: Texas Instruments, Post Office Box 655303, Dallas, Texas 75265
Copyright © 2024, Texas Instruments Incorporated

Looking for pricing, stock, or lifecycle information?

Click below to explore more details on WIN SOURCE:

 [View INA168QDBVRQ1](#) on WIN SOURCE

 [Texas Instruments](#) Information

Optimize Your Supply Chain with WIN SOURCE Solutions

-  Global Sourcing Solution
-  Obsolete Management
-  Cost Control Management
-  Shortage Management
-  Alternative Solution
-  Excess Inventory Management