

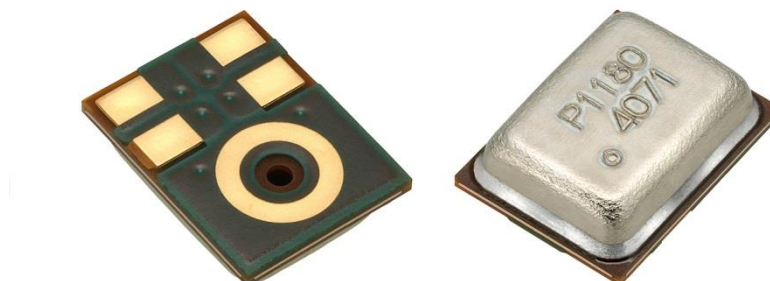

**THE DATASHEET OF
SPH0641LU4H-1**



Digital Zero-Height SiSonic™ Microphone With Multi-Mode And Ultrasonic Support



The SPH0641LU4H-1 is a miniature, high-performance, low power, bottom port silicon digital microphone with a single bit PDM output. Using Knowles' proven high performance SiSonic™ MEMS technology, the SPH0641LU4H-1 consists of an acoustic sensor, a low noise input buffer, and a sigma-delta modulator. This microphone is suitable for applications such as cellphones, smart phones, laptop computers, sensors, digital still cameras, portable music recorders, and other portable electronic devices where excellent wideband audio performance and RF immunity are required. In addition, the SPH0641LU4H-1 offers multiple performance modes and supports ultrasonic applications.

Features:

- High SNR of 64.3dB
- Low Current Consumption of 235uA in Low-Power Mode
- Multiple performance modes (Sleep, Low-Power, Standard Performance and Ultrasonic Modes)
- Flat Frequency Response
- RF Shielded
- Zero-Height Mic™
- Supports Dual Multiplexed Channels
- Omnidirectional
- Ultrasonic Support
- Sensitivity Matching
- Small Size
- Standard SMD Reflow
- LGA Package

1. ABSOLUTE MAXIMUM RATINGS

Parameter	Absolute Maximum Rating	Units
V_{DD} , DATA to Ground	-0.3, +5.0	V
CLOCK to Ground	-0.3, +5.0	V
SELECT to Ground	-0.3, +5.0	V
Input Current	±5	mA
Short Circuit Current to/from DATA	Indefinite to Ground or V_{DD}	sec
Temperature Range	-40 to +100	°C

Stresses exceeding these “Absolute Maximum Ratings” may cause permanent damage to the device. These are stress ratings only. Functional operation at these or any other conditions beyond those indicated under “Acoustic & Electrical Specifications” is not implied. Exposure beyond those indicated under “Acoustic & Electrical Specifications” for extended periods may affect device reliability.

2. ACOUSTIC & ELECTRICAL SPECIFICATIONS

TEST CONDITIONS: 23 ±2°C, 55±20% R.H., V_{DD} =1.8 V, f_{CLOCK} =2.4 MHz, SELECT pin grounded, no load, unless otherwise indicated

General Microphone Specifications

Parameter	Symbol	Conditions	Min	Typ	Max	Units
Supply Voltage	V_{DD}		1.62	-	3.6	V
Clock Frequency Range	Sleep Mode		0		250	KHz
	Low-Power Mode		351		815	KHz
	Standard Performance Mode		1.024		2.475	MHz
	Ultrasonic Mode		3.072		4.8	MHz
Sleep Current ^{1,3}	I_{SLEEP}	$f_{CLOCK} \leq 250$ kHz	-	80		µA
DC Output		Fullscale = ±100	-	0	-	% FS
Directivity			Omnidirectional			
Polarity		Increasing sound	Increasing density of 1's			
Data Format			½ Cycle PDM			
Short Circuit Current	I_{SC}	Grounded DATA pin	1	-	20	mA
Output Load	C_{LOAD}		-	-	140	pF
Fall-asleep Time ^{4,5}		$f_{CLOCK} \leq 250$ kHz	-	-	10	ms
Wake-up Time ^{4,6}		$f_{CLOCK} \geq 351$ kHz	-	-	15	ms

SPH0641LU4H-1

Parameter	Symbol	Conditions	Min	Typ	Max	Units
Power-up Time ^{4,6}		$V_{DD} \geq V(\text{min})$	-	-	50	ms
Mode-Change Time ⁴			-	-	10	ms

Ultrasonic Mode

TEST CONDITIONS: $f_{\text{CLOCK}} = 3.072 \text{ MHz}$, $V_{DD} = 1.8 \text{ V}$, unless otherwise indicated

Parameter	Symbol	Conditions	Min	Typ	Max	Units
Supply Current ^{2,3}	I_{DD}		-	845	1000	μA
Sensitivity	S	94 dB SPL @ 1 kHz	-27	-26	-25	dBFS
Signal to Noise Ratio	SNR	94 dB SPL @ 1 kHz, A-weighted	-	64.3	-	dB(A)
Total Harmonic Distortion	THD	94 dB SPL @ 1 kHz, S = Typ	-	0.2	-	%
Acoustic Overload Point	AOP	10% THD @ 1 kHz, S = Typ	-	120	-	dB SPL
Power Supply Rejection Ratio	PSRR	200 mVpp sinewave @ 1 kHz	-	55	-	dBV/FS
Power Supply Rejection	PSR+N	100 mVpp square wave @ 217 Hz, A-weighted	-	-84	-	dBFS (A)

Standard Performance Mode

TEST CONDITIONS: $f_{\text{CLOCK}} = 2.4 \text{ MHz}$, $V_{DD} = 1.8 \text{ V}$, unless otherwise indicated

Parameter	Symbol	Conditions	Min	Typ	Max	Units
Supply Current ^{1,2,3}	I_{DD}	$f_{\text{CLOCK}} = 2.4 \text{ MHz}$	-	620	700	μA
Sensitivity ¹	S	94 dB SPL @ 1 kHz	-27	-26	-25	dBFS
Signal to Noise Ratio	SNR	94 dB SPL @ 1 kHz, A-weighted, $f_{\text{CLOCK}} = 2.4 \text{ MHz}$	-	64.3	-	dB(A)
Total Harmonic Distortion	THD	94 dB SPL @ 1 kHz, S = Typ	-	0.2	-	%
Acoustic Overload Point	AOP	10% THD @ 1 kHz, S = Typ	-	120	-	dB SPL
Power Supply Rejection Ratio	PSRR	200 mVpp sinewave @ 1 kHz	-	55	-	dBV/FS
Power Supply Rejection	PSR+N	100 mVpp square wave @ 217 Hz, A-weighted	-	-84	-	dBFS (A)

SPH0641LU4H-1

Low-Power Mode

TEST CONDITIONS: $f_{\text{CLOCK}} = 768 \text{ kHz}$, $V_{\text{DD}} = 1.8 \text{ V}$, unless otherwise indicated

Parameter	Symbol	Conditions	Min	Typ	Max	Units
Supply Current ^{2,3}	I_{DD}	$f_{\text{CLOCK}} = 768 \text{ kHz}$	-	235	270	μA
Sensitivity	S	94 dB SPL @ 1 kHz	-27	-26	-25	dBFS
Signal to Noise Ratio	SNR	94 dB SPL @ 1 kHz, A-weighted (20 Hz - 8 kHz)	-	64	-	dB(A)
Total Harmonic Distortion	THD	94 dB SPL @ 1 kHz, S = Typ	-	0.2	-	%
Acoustic Overload Point	AOP	10% THD @ 1 kHz, S = Typ	-	120	-	dB SPL
Power Supply Rejection Ratio	PSRR	200 mVpp sinewave @ 1 kHz	-	59	-	dBV/FS
Power Supply Rejection	PSR+N	100 mVpp square wave @ 217 Hz, A-weighted (20Hz - 8kHz)	-	-86	-	dBFS (A)

Microphone Interface Specifications

Parameter	Symbol	Conditions	Min	Typ	Max	Units
Logic Input High	V_{IH}		$0.7 \times V_{\text{DD}}$	-	3.6	V
Logic Input Low	V_{IL}		-0.3	-	$0.3 \times V_{\text{DD}}$	V
Logic Output High	V_{OH}	$I_{\text{OUT}} = 2 \text{ mA}$	$V_{\text{DD}} - 0.45$	-	V_{DD}	V
Logic Output Low	V_{OL}	$I_{\text{OUT}} = 2 \text{ mA}$	0	-	0.45	V
Clock Duty Cycle		$f_{\text{CLOCK}} \leq 2.4 \text{ MHz}$	40	-	60	%
		$2.4 \text{ MHz} < f_{\text{CLOCK}} \leq 4.8 \text{ MHz}$	48	50	52	%
Clock Rise/Fall Time	t_{EDGE}		-	-	3	ns
Delay Time for Data Assertion	t_{DD}		18	28	40	ns
Delay Time for High Z ⁷	t_{DZ}		3	-	16	ns

¹ 100% tested.

² I_{DD} varies with C_{LOAD} according to: $\Delta I_{\text{DD}} = 0.5 \times V_{\text{DD}} \times \Delta C_{\text{LOAD}} \times f_{\text{CLOCK}}$.

³ Typical and Maximum specifications are measured at standard test conditions.

⁴ Valid microphone states are: Powered Down Mode (mic off), Sleep Mode (low current, DATA = high-Z, fast startup), Low-Power Mode (low clock speed), Standard Performance Mode (normal operation), and Ultrasonic Mode (high clock speed).

⁵ Time from $f_{\text{CLOCK}} < 250 \text{ kHz}$ to I_{SLEEP} specification is met when transitioning from Active Mode to Sleep Mode.

⁶ Time from $f_{\text{CLOCK}} \geq 351 \text{ kHz}$ to all applicable specifications are met when transitioning from Sleep Mode to Active Mode.

⁷ t_{HOLD} is dependent on C_{LOAD} .

3. MICROPHONE STATE DIAGRAM

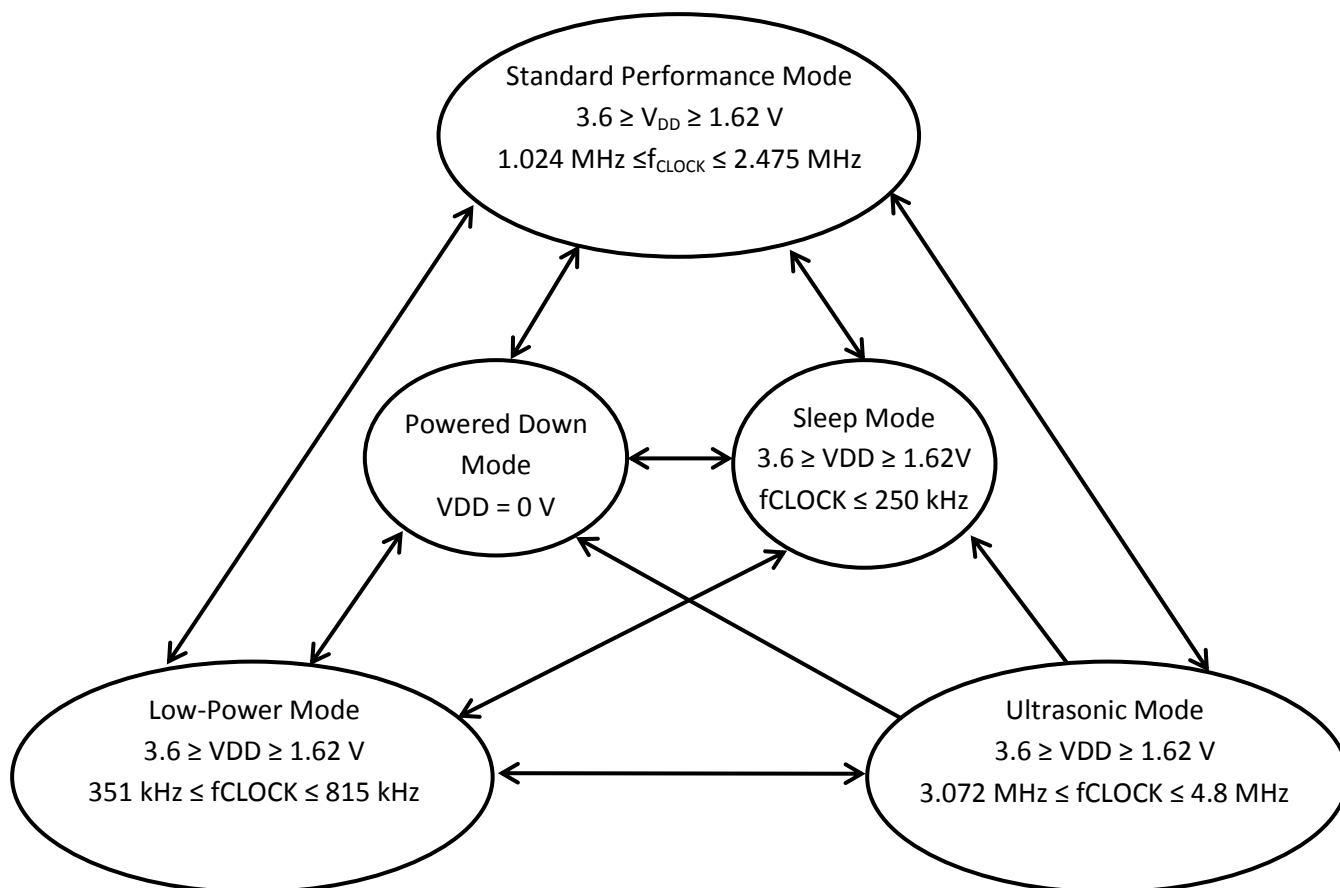

Note: Do not power up into ultrasonic mode.
Do not wake-up from sleep mode into ultrasonic mode.

4. FREQUENCY RESPONSE CURVE

Typical Free Field Response
Normalized to 1 kHz
CLK=2.4MHz VDD=1.8V

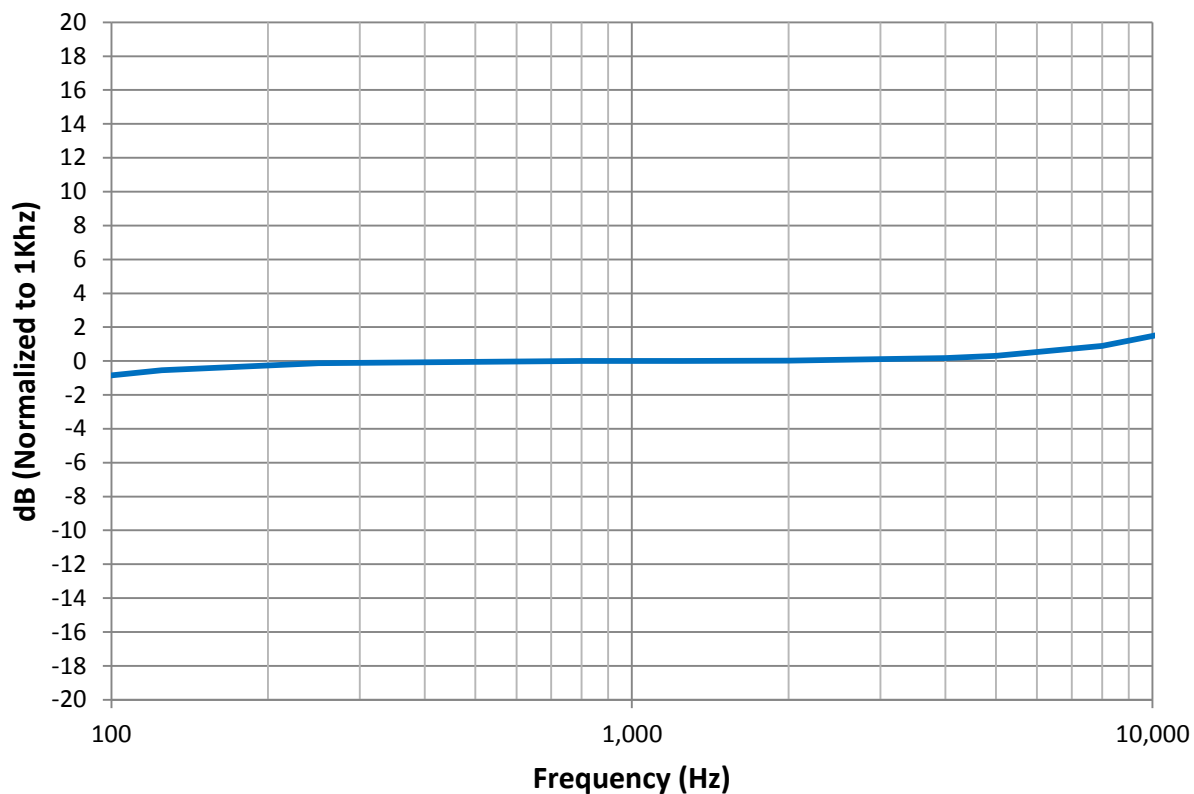

5. ULTRASONIC RESPONSE CURVE

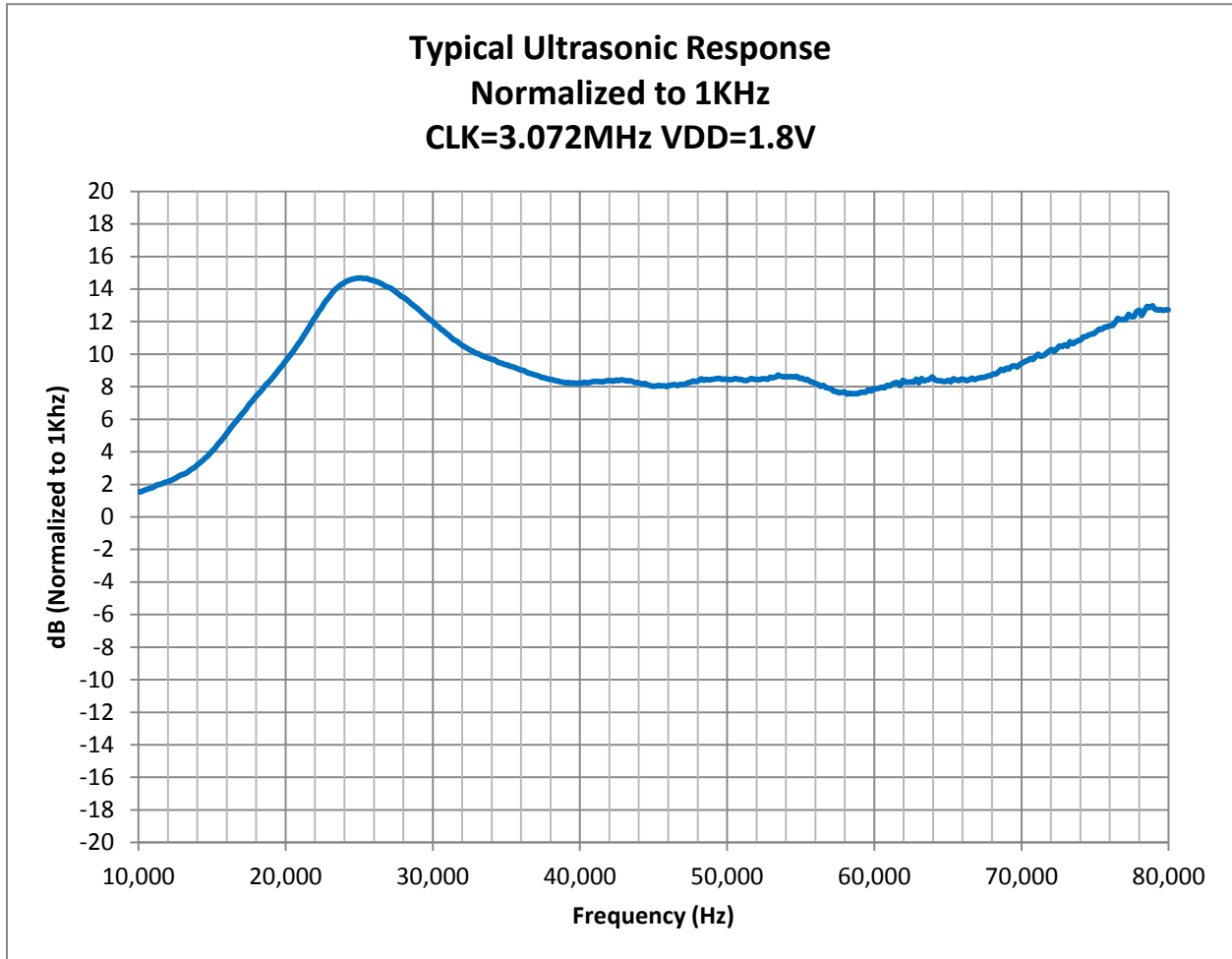

6. INTERFACE CIRCUIT

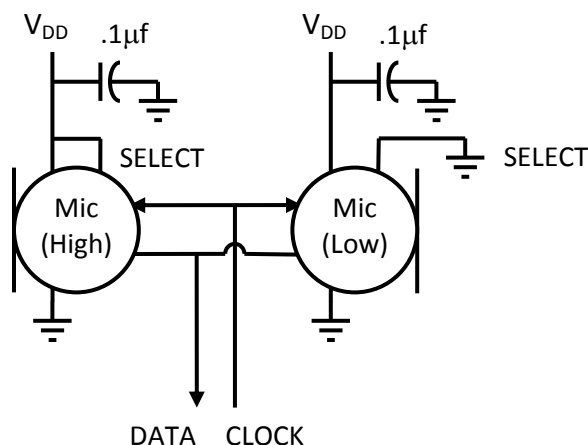

Microphone	SELECT	Asserts DATA On	Latch DATA On
Mic (High)	V _{DD}	Rising Clock Edge	Falling Clock Edge
Mic (Low)	GND	Falling Clock Edge	Rising Clock Edge

Note: Bypass capacitors near each Mic V_{DD} PIN are recommended to provide maximum SNR performance. Capacitors near the microphone should not contain Class 2 dielectrics. Detailed information on acoustic, mechanical, and system integration can be found in the latest *SiSonic™ Design Guide* application note.

7. TIMING DIAGRAM

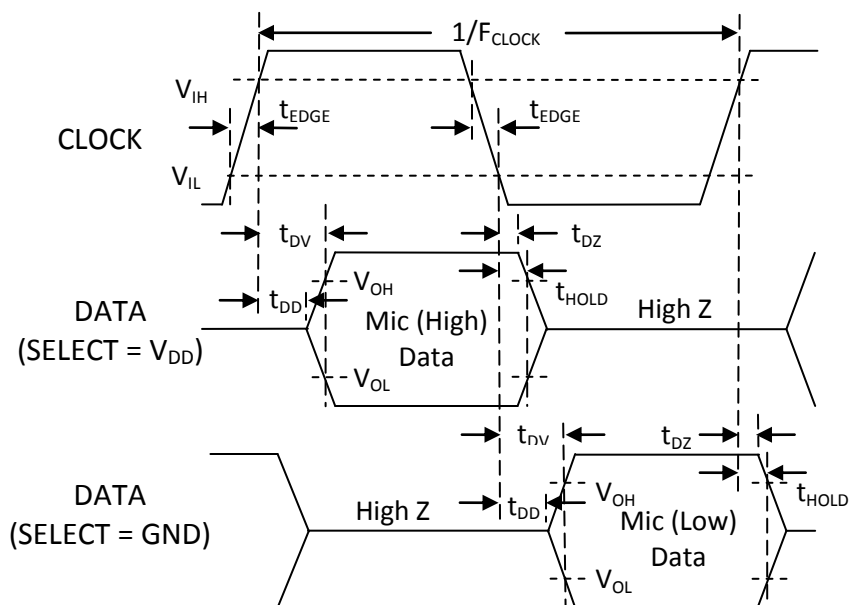

8. MECHANICAL SPECIFICATIONS

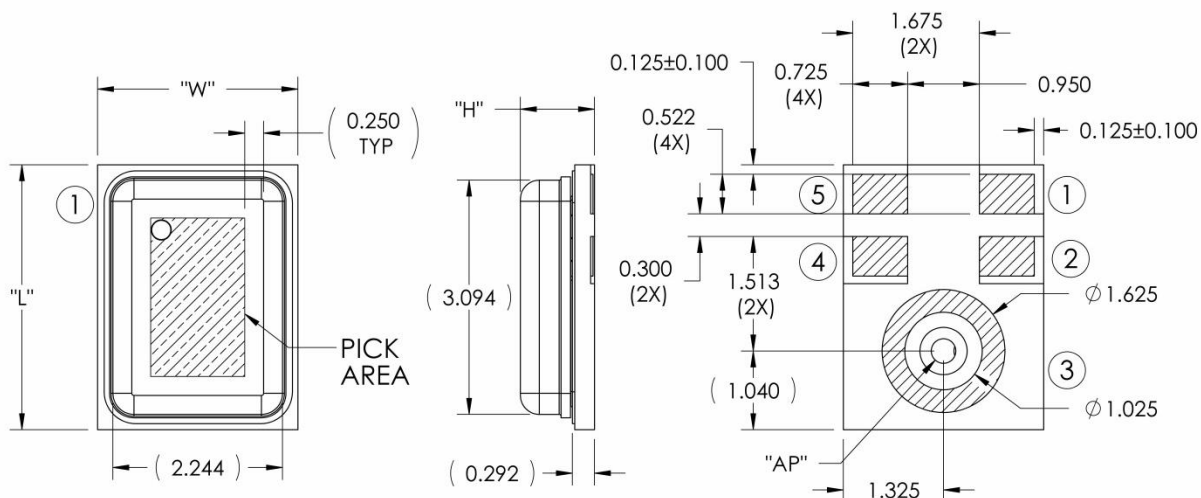

Item	Dimension	Tolerance
Length (L)	3.50	±0.10
Width (W)	2.65	±0.10
Height (H)	0.98	±0.10
Acoustic Port (AP)	∅0.325	±0.05

Pin #	Pin Name	Type	Description
1	DATA	Digital O	PDM Output
2	SELECT	Digital I	Lo/Hi (L/R) Select This pin is internally pulled low but should not be left floating.
3	GROUND	Power	Ground
4	CLOCK	Digital I	Clock Input
5	V _{DD}	Power	Power Supply

Notes: Pick Area only extends to 0.25 mm of any edge or hole unless otherwise specified.

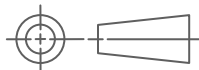

Dimensions are in millimeters unless otherwise specified.

Tolerance is ±0.15mm unless otherwise specified

9. EXAMPLE LAND PATTERN

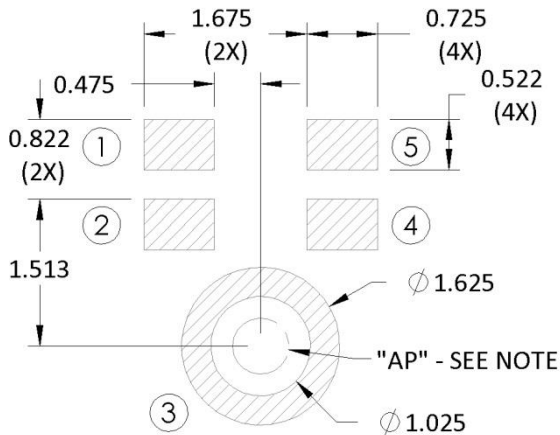

10. EXAMPLE SOLDER STENCIL PATTERN

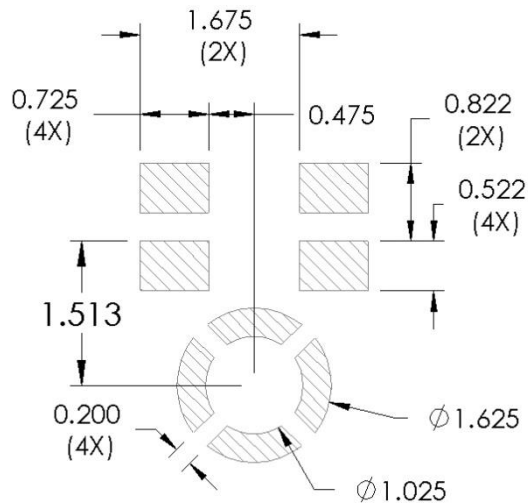

Notes: Dimensions are in millimeters unless otherwise specified.

Detailed information on AP size considerations can be found in the latest *SiSonic™ Design Guide* application note.

Further optimizations based on application should be performed.

11. PACKAGING & MARKING DETAIL

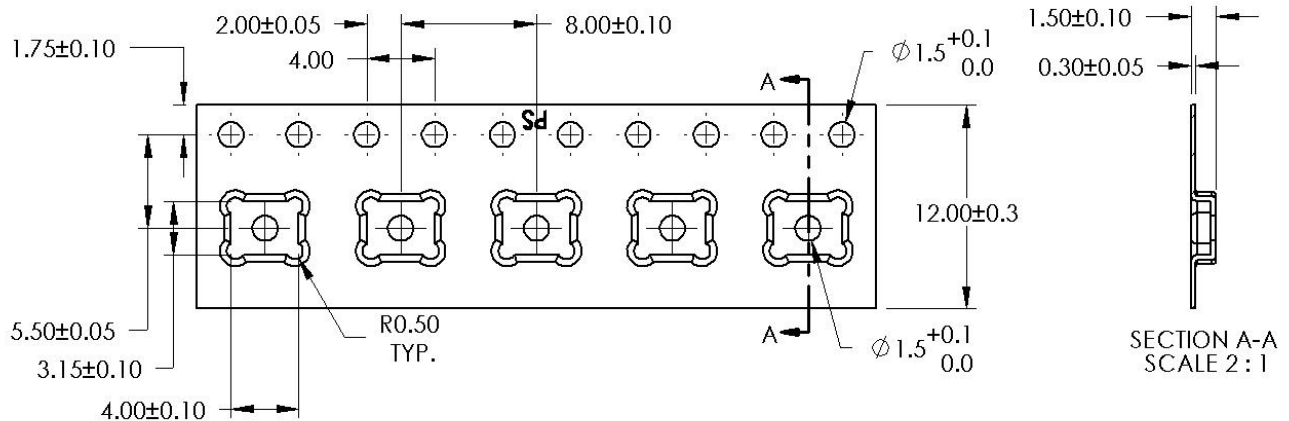

Model Number	Suffix	Reel Diameter	Quantity Per Reel
SPH0641LU4H-1	-8	13"	5,900

Alpha Character A:

“S”: Knowles SiSonic™ Production

“E”: Knowles Engineering Samples

“P”: Knowles Prototype Samples

“JIN NUMBER”:

Unique Job Identification Number for product traceability

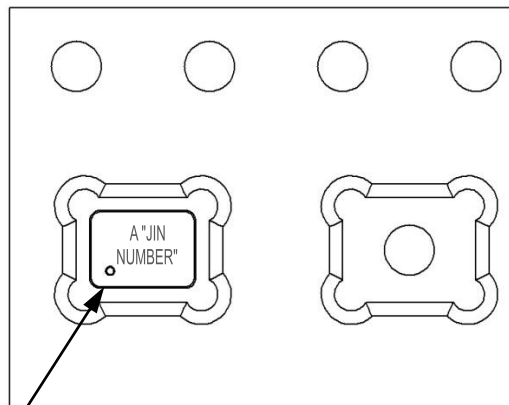

Pin 1

Notes: Dimensions are in millimeters unless otherwise specified.

Vacuum pickup only in the pick area indicated in Mechanical Specifications.

Tape & reel per EIA-481.

Labels applied directly to reel and external package.

Shelf life: Twelve (12) months when devices are to be stored in factory supplied, unopened ESD moisture sensitive bag under maximum environmental conditions of 30°C, 70% R.H.

12. RECOMMENDED REFLOW PROFILE

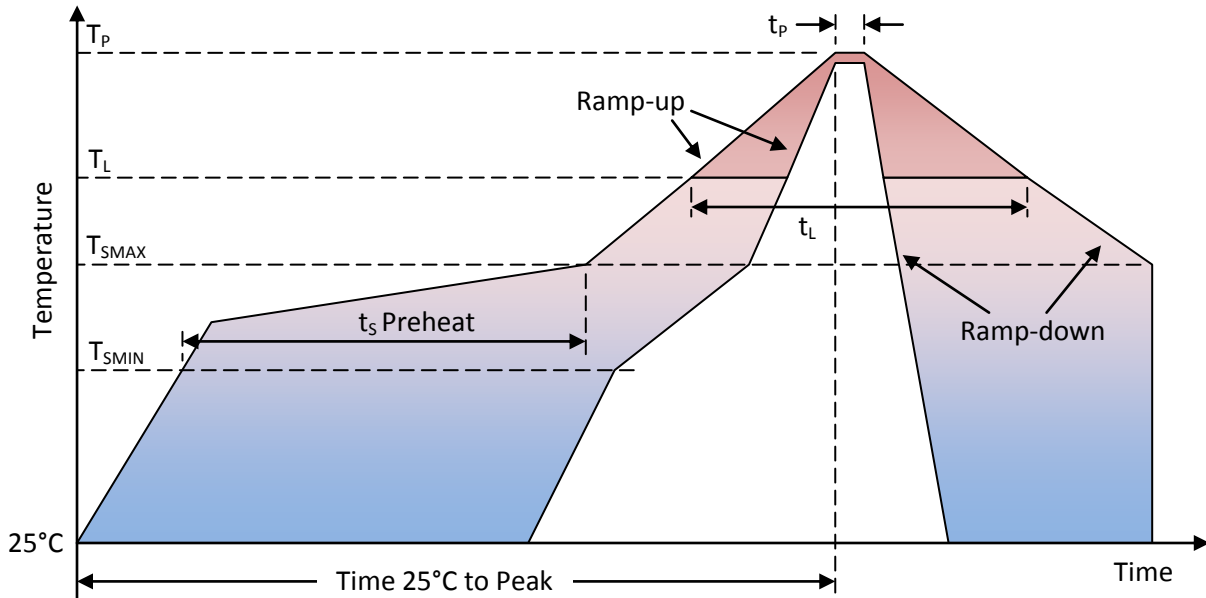

Profile Feature	Pb-Free
Average Ramp-up rate (T_{SMAX} to T_P)	3°C/second max.
Preheat <ul style="list-style-type: none"> • Temperature Min (T_{SMIN}) • Temperature Max (T_{SMAX}) • Time (T_{SMIN} to T_{SMAX}) (t_s) 	150°C 200°C 60-180 seconds
Time maintained above: <ul style="list-style-type: none"> • Temperature (T_L) • Time (t_L) 	217°C 60-150 seconds
Peak Temperature (T_P)	260°C
Time within 5°C of actual Peak Temperature (t_p)	20-40 seconds
Ramp-down rate (T_P to T_{SMAX})	6°C/second max
Time 25°C to Peak Temperature	8 minutes max

Notes: Based on IPC/JDEC J-STD-020 Revision C.

All temperatures refer to topside of the package, measured on the package body surface.

13. ADDITIONAL NOTES

(A) MSL (moisture sensitivity level) Class 1.

(B) Maximum of 3 reflow cycles is recommended.

(C) In order to minimize device damage:

- Do not board wash or clean after the reflow process.
- Do not brush board with or without solvents after the reflow process.
- Do not directly expose to ultrasonic processing, welding, or cleaning.
- Do not insert any object in port hole of device at any time.
- Do not apply over 30 psi of air pressure into the port hole.
- Do not pull a vacuum over port hole of the microphone.
- Do not apply a vacuum when repacking into sealed bags at a rate faster than 0.5 atm/sec.

14. MATERIALS STATEMENT

Meets the requirements of the European RoHS directive 2011/65/EC as amended.

Meets the requirements of the industry standard IEC 61249-2-21:2003 for halogenated substances and Knowles Green Materials Standards Policy section on Halogen-Free.

Ozone depleting substances are not used in the product or the processes used to make the product, including compounds listed in Annex A, B, and C of the “Montreal Protocol on Substances That Deplete the Ozone Layer.”

15. RELIABILITY SPECIFICATIONS

Test	Description
Thermal Shock	100 cycles air-to-air thermal shock from -40°C to +125°C with 15 minute soaks. (IEC 68-2-4)
High Temperature Storage	1,000 hours at +105°C environment (IEC 68-2-2 Test Ba)
Low Temperature Storage	1,000 hours at -40°C environment (IEC 68-2-2 Test Aa)
High Temperature Bias	1,000 hours at +105°C under bias (IEC 68-2-2 Test Ba)
Low Temperature Bias	1,000 hours at -40°C under bias (IEC 68-2-2 Test Aa)
Temperature / Humidity Bias	1,000 hours at +85°C/85% R.H. under bias. (JESD22-A101A-B)
Vibration	4 cycles of 20 to 2,000 Hz sinusoidal sweep with 20 G peak acceleration lasting 12 minutes in X, Y, and Z directions. (Mil-Std-883E, method 2007.2 A)
ESD-LID/GND	3 discharges of ±8 kV direct contact to lid while unit is grounded. (IEC 61000-4-2)
ESD-MM	3 discharges of ±200V direct contact to I/O pins. (ESD STM5.2)
Reflow	5 reflow cycles with peak temperature of +260°C
Mechanical Shock	3 pulses of 10,000 G in the X, Y, and Z direction (IEC 68-2-27, Test Ea)

Note: After reliability tests are performed, the sensitivity of the microphones shall not deviate more than 3 dB from its initial value.

After 3 reflow cycles, the sensitivity of the microphones shall not deviate more than 1 dB from its initial value.

16. SPECIFICATION REVISIONS

Revision	Specification Changes	Date
A	Initial Release(C10115945)	5/16/14
B	Updated State Diagram(DCN 15-180)	4/06/15

Information contained herein is subject to change without notice. It may be used by a party at their own discretion and risk. We do not guarantee any results or assume any liability in connection with its use. This publication is not to be taken as a license to operate under any existing patents.

Looking for pricing, stock, or lifecycle information?

Click below to explore more details on WIN SOURCE:

 [View SPH0641LU4H-1 on WIN SOURCE](#)

 [Knowles](#) Information

Optimize Your Supply Chain with WIN SOURCE Solutions

-  Global Sourcing Solution
-  Obsolete Management
-  Cost Control Management
-  Shortage Management
-  Alternative Solution
-  Excess Inventory Management