



**THE DATASHEET OF  
ICL7667CPA+**



# MAXIM

## Dual Power MOSFET Driver

ICL7667

### General Description

The ICL7667 is a dual monolithic power MOSFET driver designed to translate TTL inputs to high voltage/current outputs. Its low delay and transition times make it ideal to drive power MOSFETs for switching power supplies, motor controllers, and DC-DC converters. The ICL7667's CMOS output stage drives within millivolts of the supply rail, allowing the power MOSFETs their minimum ON resistance. The ICL7667's high speed minimizes power losses in switching power supplies and DC-DC converters due to rapid charging/discharging of the gate capacitance of the power MOSFETs. The ICL7667 inputs are TTL compatible, enabling direct interface to common switched mode power supply controllers.

### Features

- ◆ Fast Rise and Fall Times – Typically 20ns with 1000pF Load
- ◆ Wide Supply Range:  $V_{DD} = 4.5V$  to 17V
- ◆ Low Power Consumption:  
6mW with Inputs Low  
120mW with Inputs High
- ◆ TTL/CMOS Input Compatible
- ◆ Low  $R_{OUT}$  – Typically 4 $\Omega$
- ◆ Pin Equivalent to DS0026/DS0056, TSC426, SG1626/SG2626/SG3626

### Applications

Switching Power Supplies  
DC-DC Converters  
Motor Controllers  
Pin Diode Drivers

### Ordering Information

PART	TEMP. RANGE	PACKAGE
ICL7667CBA	0°C to +70°C	8 Lead SO
ICL7667CPA	0°C to +70°C	8 Lead Plastic DIP
ICL7667CJA	0°C to +70°C	8 Lead CERDIP
ICL7667MJA	-55°C to +125°C	8 Lead CERDIP

### Functional Diagram

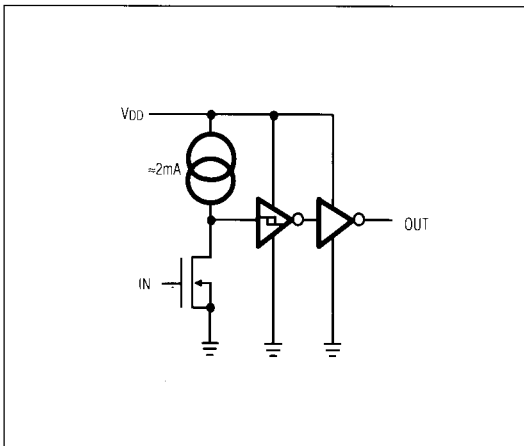

### Pin Configuration

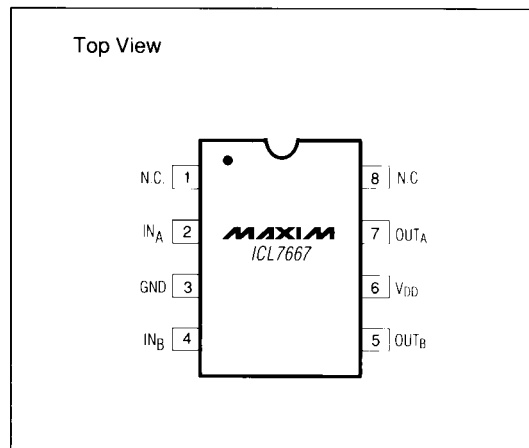

**ICL7667**

## Dual Power MOSFET Driver

### ABSOLUTE MAXIMUM RATINGS

Supply Voltage $V_{DD}$ to GND	18V	Maximum Chip Temperature	+150°C
Input Voltage	$V_{DD} + 0.3V$ to GND $- 0.3V$	Storage Temperature	-55°C to 160°C
Package Dissipation (derate linearly above 50°C by 5.5mW/°C)		Lead Temperature (Soldering 10 seconds)	+300°C
Plastic Dip	300mW		
Small Outline	200mW		
CERDIP	400mW		

Stresses above those listed under "Absolute Maximum Ratings" may cause permanent damage to the device. These are stress ratings only, and functional operation of the device at these or any other conditions above those indicated in the operational sections of the specification is not implied. Exposure to absolute maximum rating conditions for extended periods may affect the device reliability.

### ELECTRICAL CHARACTERISTICS ( $V_{DD} = 15V$ , Over Temperature, unless otherwise noted.)

PARAMETER	SYMBOL	CONDITIONS	MIN	TYP	MAX	UNITS
Logic 1 Input Voltage	$V_{IH}$	$V_{DD} = 4.5V$ to 17V	2.0			V
Logic 0 Input Voltage	$V_{IL}$	$V_{DD} = 4.5V$ to 17V			0.8	V
Input Current	$I_{IN}$	$V_{IN} = 0V$ to 15V	-0.1		0.1	$\mu A$
Output High Voltage	$V_{OH}$	$V_{DD} = 15V$ , No load	14.95			V
Output Low Voltage	$V_{OL}$	$V_{DD} = 15V$ , No load			0.05	V
Output Resistance	$R_{OUT}$	$V_{IN} = V_{IL}$ , $I_{OUT} = +10mA$ , $T_A = 25^\circ C$ $V_{IN} = V_{IH}$ , $I_{OUT} = -10mA$ , $T_A = 25^\circ C$ $V_{IN} = V_{IL}$ , $I_{OUT} = +10mA$ $V_{IN} = V_{IH}$ , $I_{OUT} = -10mA$		4 4 6 6	10 12 12 13	$\Omega$
Power Supply Current	$I_{DD}$	$V_{IN} = +3V$ , both inputs, $T_A = 25^\circ C$ $V_{IN} = 0V$ , both inputs, $T_A = 25^\circ C$ $V_{IN} = +3V$ , both inputs $V_{IN} = 0V$ , both inputs			7 0.4 8 0.4	mA
Delay Time	$t_{D1}$ (Note 1)	Figure 1, $C_{LOAD} = 1nF$ , $T_A = 25^\circ C$ Figure 1, $C_{LOAD} = 1nF$		20 25	30 40	ns
Delay Time	$t_{D2}$ (Note 1)	Figure 1, $C_{LOAD} = 1nF$ , $T_A = 25^\circ C$ Figure 1, $C_{LOAD} = 1nF$		25 30	50 60	
Rise Time	$t_R$ (Note 1)	Figure 1, $C_{LOAD} = 1nF$ , $T_A = 25^\circ C$ Figure 1, $C_{LOAD} = 1nF$		20 25	30 40	
Fall Time	$t_F$ (Note 1)	Figure 1, $C_{LOAD} = 1nF$ , $T_A = 25^\circ C$ Figure 1, $C_{LOAD} = 1nF$		20 25	30 40	

**Note 1:** Switching times guaranteed by design, not tested.

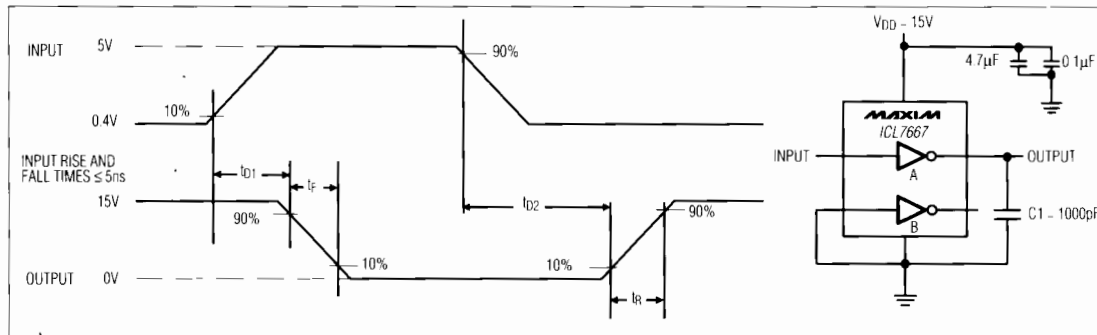
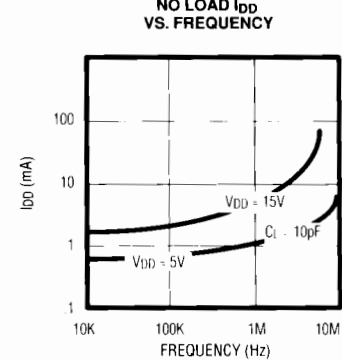
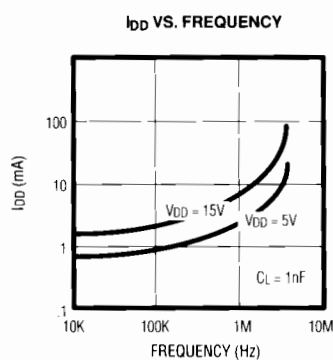
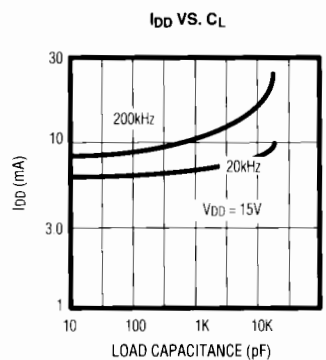
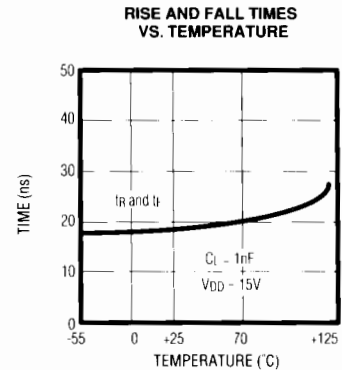
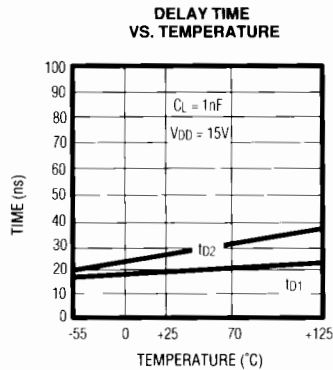
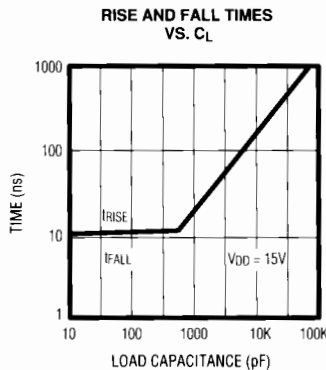

Figure 1. Test Circuit

# Dual Power MOSFET Driver

## Typical Operating Characteristics

ICL7667



### Introduction

The ICL7667 is a dual inverting power MOSFET driver. Its delay times are nearly independent of  $V_{DD}$ . The high current output inverters can rapidly charge and discharge the gate capacitance of even the largest power MOSFETs. Since the ICL7667's inputs are CMOS, very little current is required to interface to the ICL7667. Although the ICL7667 has an input that is easy to drive, the input must never be allowed to stay between  $V_{IH}$  and  $V_{IL}$  for more than 50ns.

Other potential applications include charge pump voltage inverters and charge pump voltage multipliers.

### Circuit Description

The input stage of the ICL7667 consists of a large N channel transistor with a 2mA current source as a pull-up device. The second stage inverter has a feedback device to provide some hysteresis for cleaner input switching. The output stage is a very large inverter with separate gate drives to minimize crowbar current through the supplies. The simplicity of the circuit allows for very fast delay and switching times. Unused inputs should always be connected to ground to minimize supply current. Paralleling outputs can be done by tying both inputs together and tying both outputs together.

## Dual Power MOSFET Driver

### Supply Bypassing and Grounding

Supply bypassing and grounding are extremely important with the ICL7667 product as the peak currents (both supply and output) are >1 amp. Ground drops are a form of negative feedback with inverters and will degrade the delay and transition time of the ICL7667. The suggested bypass capacitors are a 4.7µF (low ESR) capacitor in parallel with a 0.1µF ceramic capacitor. These should be mounted as close as possible to the ICL7667. Use a ground plane if possible, or use separate ground returns for the inputs and outputs.

### Output Ringing

Ringing is a common problem with large dV/dt and/or large AC currents. Some preventative suggestions are:

- 1.) Use a small resistor 5-20Ω in series with the output. (This will unfortunately degrade the output transition times);
- 2.) Reduce the inductance of the ground by using a ground plane;
- 3.) Use lower ESR capacitors to bypass the ICL7667.

### Power Dissipation

The power dissipation of the ICL7667 consists of three parts:

- 1.) Input inverter losses;
- 2.) Crowbar current through the output devices;
- 3.) Output current (either capacitive or resistive).

The sum of these is the total power dissipation and must be kept below the maximum power dissipation listed for the package.

The Input inverter losses come from the DC current in the input inverter. This current is 0.4mA when both inputs are low and 4mA when both inputs are high.

The Crowbar current through the output devices is the current "glitch" when the output is making a transition. This current is large (approximately 100mA) but lasts for only a few nanoseconds. It generally is a small portion of the total supply current unless the switching frequency is high and the capacitive load is very small (<100pF).

The Output current can be resistive current (example, driving an LED) or capacitive current (example, driving the gate of a power MOSFET). The ICL7667 power when driving a ground referenced resistive load is:

$$P = D \times R_{ON(MAX)} \times I_{LOAD}^2$$

where D is the percentage of time the ICL7667 output pulls high,  $R_{ON(MAX)}$  is the maximum on resistance of the ICL7667 with  $V_{IN} = V_{IH}$ , and  $I_{LOAD}$  is the load current flowing into the ICL7667.

If the output load is capacitive, then the power is:

$$P = C_{LOAD} \times V_{DD}^2 \times FREQ$$

where  $C_{LOAD}$  is the capacitive load,  $V_{DD}$  is the ICL7667 supply, and FREQ is the toggle frequency.

### Chip Topography

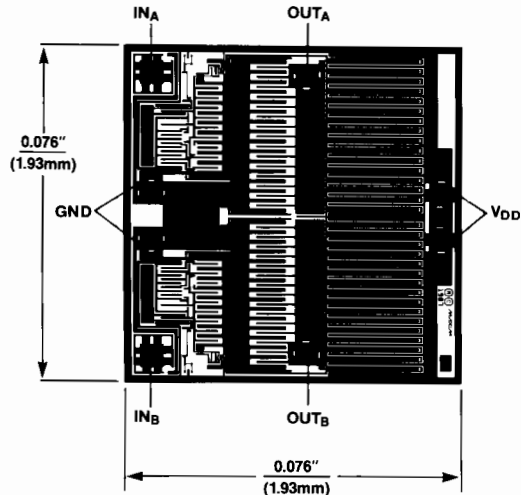

Maxim cannot assume responsibility for use of any circuitry other than circuitry entirely embodied in a Maxim product. No circuit patent licenses are implied. Maxim reserves the right to change the circuitry and specifications without notice at any time.

4 **Maxim Integrated Products, 120 San Gabriel Drive, Sunnyvale, CA 94086 (408) 737-7600**

## Looking for pricing, stock, or lifecycle information?

Click below to explore more details on WIN SOURCE:

 [View ICL7667CPA+](#) on WIN SOURCE

 [Maxim Integrated](#) Information

## Optimize Your Supply Chain with WIN SOURCE Solutions

-  Global Sourcing Solution
-  Obsolete Management
-  Cost Control Management
-  Shortage Management
-  Alternative Solution
-  Excess Inventory Management