

TPIC6B596 POWER LOGIC 8-BIT SHIFT REGISTER

SLIS095A – MARCH 2000 – REVISED MAY 2005

- Low $r_{DS(on)}$. . . 5 Ω
- Avalanche Energy . . . 30 mJ
- Eight Power DMOS-Transistor Outputs of 150-mA Continuous Current
- 500-mA Typical Current-Limiting Capability
- Output Clamp Voltage . . . 50 V
- Enhanced Cascading for Multiple Stages
- All Registers Cleared With Single Input
- Low Power Consumption

description

The TPIC6B596 is a monolithic, high-voltage, medium-current power 8-bit shift register designed for use in systems that require relatively high load power. The device contains a built-in voltage clamp on the outputs for inductive transient protection. Power driver applications include relays, solenoids, and other medium-current or high-voltage loads.

This device contains an 8-bit serial-in, parallel-out shift register that feeds an 8-bit D-type storage register. Data transfers through both the shift and storage registers on the rising edge of the shift-register clock (SRCK) and the register clock (RCK), respectively. The storage register transfers data to the output buffer when shift-register clear (\overline{SRCLR}) is high. When \overline{SRCLR} is low, all registers in the device are cleared. When output enable (\overline{G}) is held high, all data in the output buffers is held low and all drain outputs are off. When \overline{G} is held low, data from the storage register is transparent to the output buffers. When data in the output buffers is low, the DMOS-transistor outputs are off. When data is high, the DMOS-transistor outputs have sink-current capability. The serial output (SER OUT) is clocked out of the device on the falling edge of SRCK to provide additional hold time for cascaded applications. This will provide improved performance for applications where clock signals may be skewed, devices are not located near one another, or the system must tolerate electromagnetic interference.

Outputs are low-side, open-drain DMOS transistors with output ratings of 50 V and 150-mA continuous sink-current capability. Each output provides a 500-mA typical current limit at $T_C = 25^\circ\text{C}$. The current limit decreases as the junction temperature increases for additional device protection.

The TPIC6B596 is characterized for operation over the operating case temperature range of -40°C to 125°C .

DW OR N PACKAGE
(TOP VIEW)

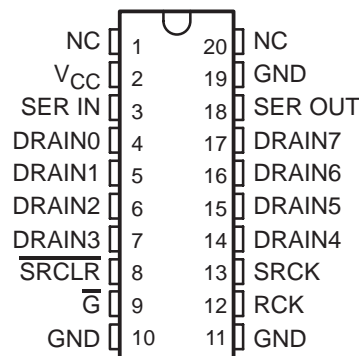

NC – No internal connection

logic symbol†

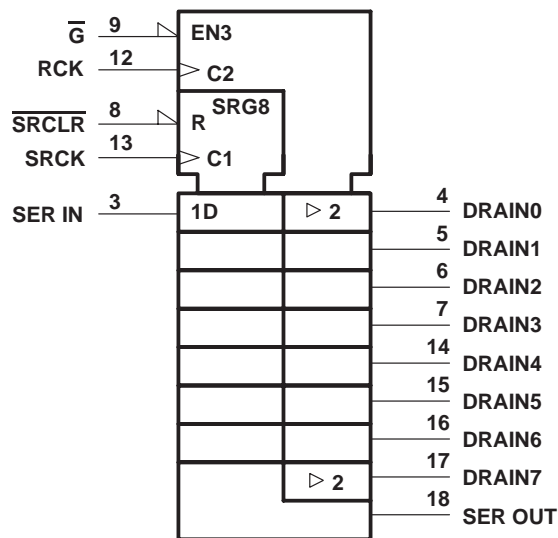

† This symbol is in accordance with ANSI/IEEE Std 91-1984 and IEC Publication 617-12.



Please be aware that an important notice concerning availability, standard warranty, and use in critical applications of Texas Instruments semiconductor products and disclaimers thereto appears at the end of this data sheet.

PRODUCTION DATA information is current as of publication date. Products conform to specifications per the terms of Texas Instruments standard warranty. Production processing does not necessarily include testing of all parameters.

 **TEXAS
INSTRUMENTS**

POST OFFICE BOX 655303 • DALLAS, TEXAS 75265

Copyright © 2000 – 2005, Texas Instruments Incorporated

TPIC6B596 POWER LOGIC 8-BIT SHIFT REGISTER

SLIS095A – MARCH 2000 – REVISED MAY 2005

logic diagram (positive logic)

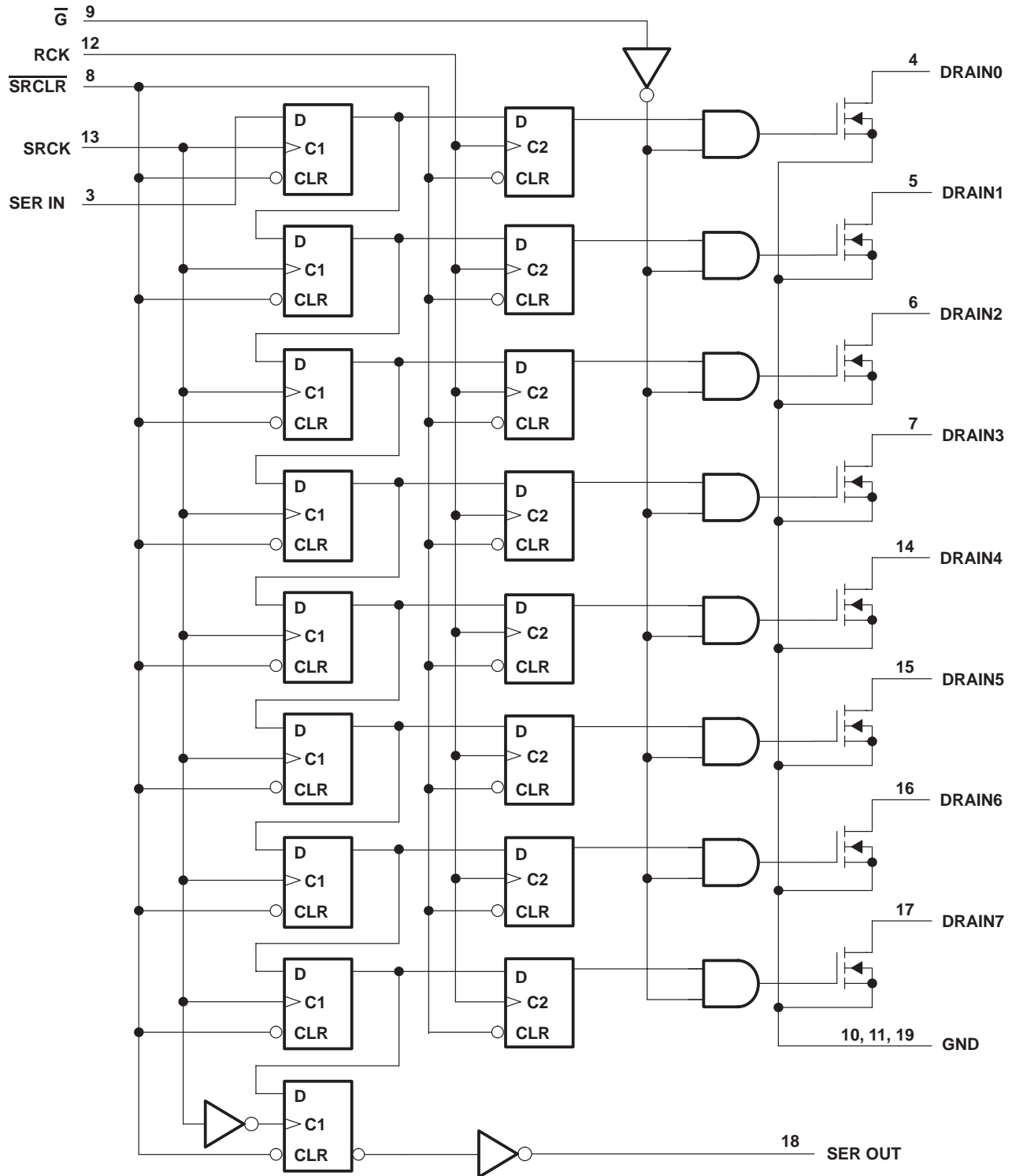

schematic of inputs and outputs

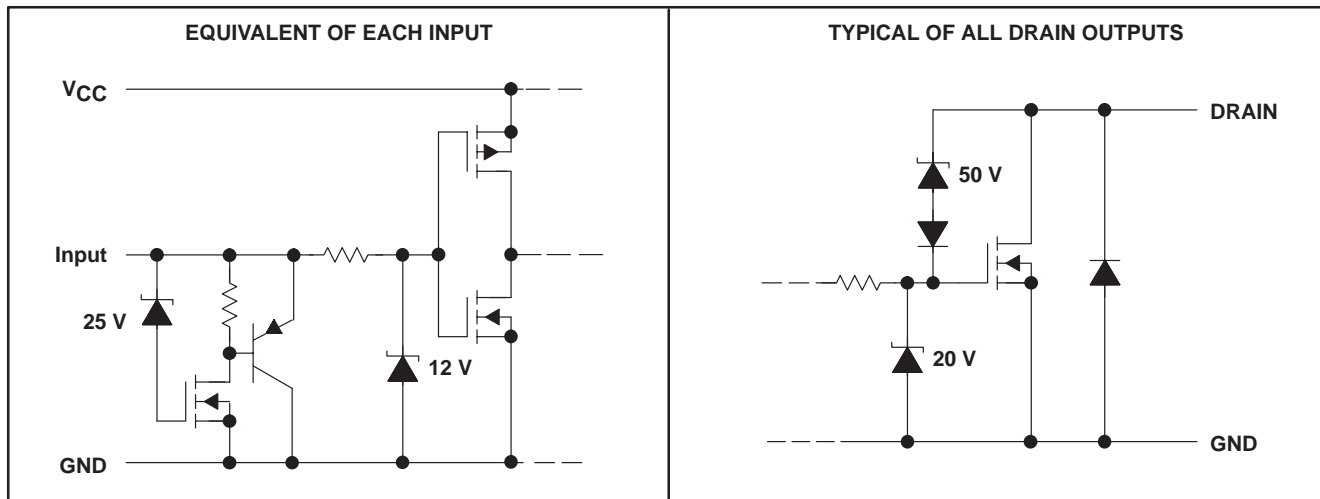

absolute maximum ratings over recommended operating case temperature range (unless otherwise noted)†

Logic supply voltage, V_{CC} (see Note 1)	7 V
Logic input voltage range, V_I	-0.3 V to 7 V
Power DMOS drain-to-source voltage, V_{DS} (see Note 2)	50 V
Continuous source-to-drain diode anode current	500 mA
Pulsed source-to-drain diode anode current (see Note 3)	1 A
Pulsed drain current, each output, all outputs on, I_D , $T_C = 25^\circ\text{C}$ (see Note 3)	500 mA
Continuous drain current, each output, all outputs on, I_D , $T_C = 25^\circ\text{C}$	150 mA
Peak drain current single output, I_{DM} , $T_C = 25^\circ\text{C}$ (see Note 3)	500 mA
Single-pulse avalanche energy, E_{AS} (see Figure 4)	30 mJ
Avalanche current, I_{AS} (see Note 4)	500 mA
Continuous total dissipation	See Dissipation Rating Table
Operating virtual junction temperature range, T_J	-40°C to 150°C
Operating case temperature range, T_C	-40°C to 125°C
Storage temperature range	-65°C to 150°C
Lead temperature 1,6 mm (1/16 inch) from case for 10 seconds	260°C

† Stresses beyond those listed under “absolute maximum ratings” may cause permanent damage to the device. These are stress ratings only, and functional operation of the device at these or any other conditions beyond those indicated under “recommended operating conditions” is not implied. Exposure to absolute-maximum-rated conditions for extended periods may affect device reliability.

- NOTES:
1. All voltage values are with respect to GND.
 2. Each power DMOS source is internally connected to GND.
 3. Pulse duration $\leq 100 \mu\text{s}$ and duty cycle $\leq 2\%$.
 4. DRAIN supply voltage = 15 V, starting junction temperature (T_{JS}) = 25°C, $L = 200 \text{ mH}$, $I_{AS} = 0.5 \text{ A}$ (see Figure 4).

DISSIPATION RATING TABLE

PACKAGE	$T_C \leq 25^\circ\text{C}$ POWER RATING	DERATING FACTOR ABOVE $T_C = 25^\circ\text{C}$	$T_C = 125^\circ\text{C}$ POWER RATING
DW	1389 mW	11.1 mW/°C	278 mW
N	1050 mW	10.5 mW/°C	263 mW

TPIC6B596

POWER LOGIC 8-BIT SHIFT REGISTER

SLIS095A – MARCH 2000 – REVISED MAY 2005

recommended operating conditions

	MIN	MAX	UNIT
Logic supply voltage, V_{CC}	4.5	5.5	V
High-level input voltage, V_{IH}	0.85 V_{CC}		V
Low-level input voltage, V_{IL}	0.15 V_{CC}		V
Pulsed drain output current, $T_C = 25^\circ\text{C}$, $V_{CC} = 5\text{ V}$ (see Notes 3 and 5)	-500	500	mA
Setup time, SER IN high before SRCK \uparrow , t_{SU} (see Figure 2)	15		ns
Hold time, SER IN high after SRCK \uparrow , t_H (see Figure 2)	15		ns
Pulse duration, t_W (see Figure 2)	40		ns
Operating case temperature, T_C	-40	125	$^\circ\text{C}$

NOTES: 3. Pulse duration $\leq 100\ \mu\text{s}$ and duty cycle $\leq 2\%$.
5. Technique should limit $T_J - T_C$ to 10°C maximum.

electrical characteristics, $V_{CC} = 5\text{ V}$, $T_C = 25^\circ\text{C}$ (unless otherwise noted)

PARAMETER	TEST CONDITIONS	MIN	TYP	MAX	UNIT	
$V_{(BR)DSX}$ Drain-to-source breakdown voltage	$I_D = 1\text{ mA}$	50			V	
V_{SD} Source-to-drain diode forward voltage	$I_F = 100\text{ mA}$		0.85	1	V	
V_{OH} High-level output voltage, SER OUT	$I_{OH} = -20\ \mu\text{A}$, $V_{CC} = 4.5\text{ V}$	4.4	4.49		V	
	$I_{OH} = -4\text{ mA}$, $V_{CC} = 4.5\text{ V}$	4	4.2			
V_{OL} Low-level output voltage, SER OUT	$I_{OL} = 20\ \mu\text{A}$, $V_{CC} = 4.5\text{ V}$		0.005	0.1	V	
	$I_{OL} = 4\text{ mA}$, $V_{CC} = 4.5\text{ V}$		0.3	0.5		
I_{IH} High-level input current	$V_{CC} = 5.5\text{ V}$, $V_I = V_{CC}$			1	μA	
I_{IL} Low-level input current	$V_{CC} = 5.5\text{ V}$, $V_I = 0$			-1	μA	
I_{CC} Logic supply current	$V_{CC} = 5.5\text{ V}$	All outputs off	20	100	μA	
		All outputs on	150	300		
$I_{CC}(\text{FRQ})$ Logic supply current at frequency	$f_{SRCK} = 5\text{ MHz}$, $C_L = 30\text{ pF}$, All outputs off, See Figures 2 and 6		0.4	5	mA	
I_N Nominal current	$V_{DS(\text{on})} = 0.5\text{ V}$, $I_N = I_D$, $T_C = 85^\circ\text{C}$	See Notes 5, 6, and 7		90	mA	
I_{DSX} Off-state drain current	$V_{DS} = 40\text{ V}$, $V_{CC} = 5.5\text{ V}$		0.1	5	μA	
	$V_{DS} = 40\text{ V}$, $V_{CC} = 5.5\text{ V}$, $T_C = 125^\circ\text{C}$		0.15	8		
$r_{DS(\text{on})}$ Static drain-source on-state resistance	$I_D = 100\text{ mA}$, $V_{CC} = 4.5\text{ V}$	See Notes 5 and 6 and Figures 7 and 8		4.2	5.7	Ω
	$I_D = 100\text{ mA}$, $T_C = 125^\circ\text{C}$, $V_{CC} = 4.5\text{ V}$			6.8	9.5	
	$I_D = 350\text{ mA}$, $V_{CC} = 4.5\text{ V}$			5.5	8	

NOTES: 5. Technique should limit $T_J - T_C$ to 10°C maximum.
6. These parameters are measured with voltage-sensing contacts separate from the current-carrying contacts.
7. Nominal current is defined for a consistent comparison between devices from different sources. It is the current that produces a voltage drop of 0.5 V at $T_C = 85^\circ\text{C}$.



switching characteristics, $V_{CC} = 5\text{ V}$, $T_C = 25^\circ\text{C}$

PARAMETER		TEST CONDITIONS	MIN	TYP	MAX	UNIT
t_{PLH}	Propagation delay time, low-to-high-level output from \overline{G}	$C_L = 30\text{ pF}$, $I_D = 100\text{ mA}$, See Figures 1, 2, and 9		150		ns
t_{PHL}	Propagation delay time, high-to-low-level output from \overline{G}			90		ns
t_r	Rise time, drain output			200		ns
t_f	Fall time, drain output			200		ns
t_{pd}	Propagation delay time, SRCK \downarrow to SEROUT	$C_L = 30\text{ pF}$, See Figure 2		15		ns
$f(\text{SRCK})$	Serial clock frequency	$C_L = 30\text{ pF}$, See Note 8			10	MHz
t_a	Reverse-recovery-current rise time	$I_F = 100\text{ mA}$, $di/dt = 20\text{ A}/\mu\text{s}$, See Notes 5 and 6 and Figure 3		100		ns
t_{rr}	Reverse-recovery time			300		

- NOTES: 5. Technique should limit $T_J - T_C$ to 10°C maximum.
 6. These parameters are measured with voltage-sensing contacts separate from the current-carrying contacts.
 8. This is the maximum serial clock frequency assuming cascaded operation where serial data is passed from one stage to a second stage. The clock period allows for SRCK \rightarrow SEROUT propagation delay and setup time plus some timing margin.

thermal resistance

PARAMETER		TEST CONDITIONS	MIN	MAX	UNIT
$R_{\theta JA}$	Thermal resistance, junction-to-ambient	DW package		90	$^\circ\text{C}/\text{W}$
		N package		95	

PARAMETER MEASUREMENT INFORMATION

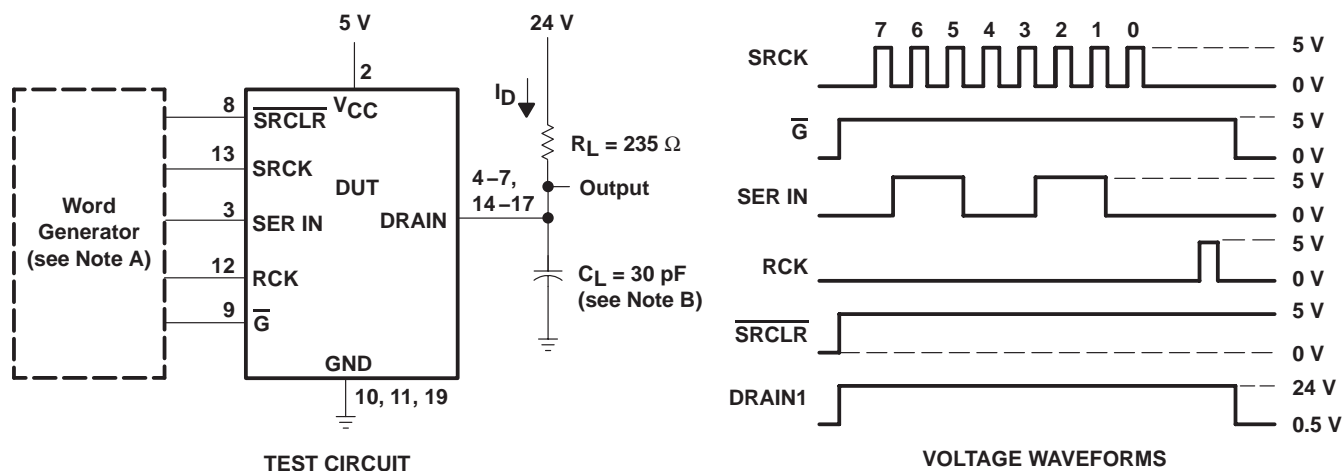

- NOTES: A. The word generator has the following characteristics: $t_r \leq 10\text{ ns}$, $t_f \leq 10\text{ ns}$, $t_w = 300\text{ ns}$, pulsed repetition rate (PRR) = 5 kHz, $Z_O = 50\ \Omega$.
 B. C_L includes probe and jig capacitance.

Figure 1. Resistive-Load Test Circuit and Voltage Waveforms

TPIC6B596 POWER LOGIC 8-BIT SHIFT REGISTER

SLIS095A – MARCH 2000 – REVISED MAY 2005

PARAMETER MEASUREMENT INFORMATION

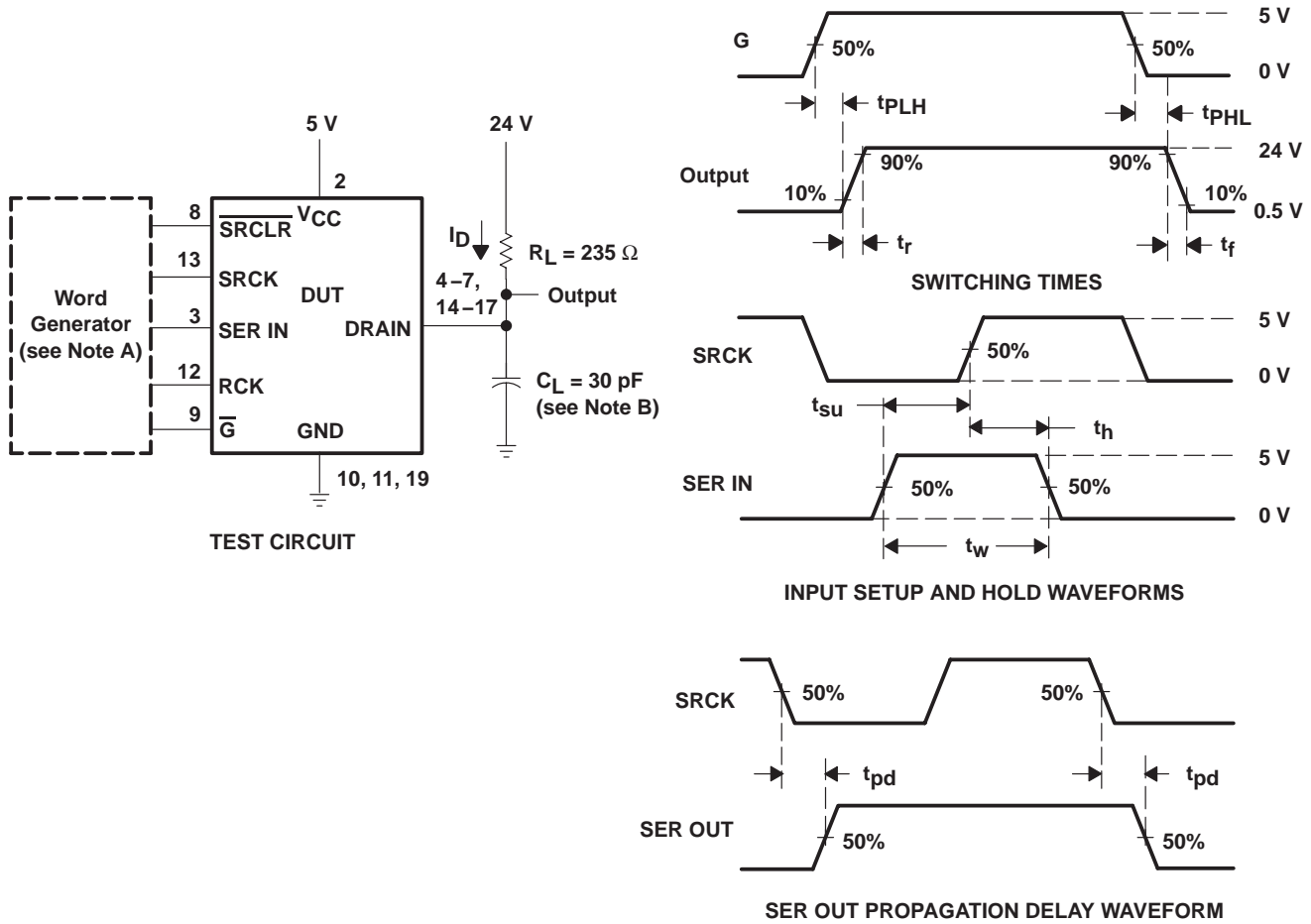

- NOTES: A. The word generator has the following characteristics: $t_r \leq 10 \text{ ns}$, $t_f \leq 10 \text{ ns}$, $t_w = 300 \text{ ns}$, pulsed repetition rate (PRR) = 5 kHz, $Z_O = 50 \Omega$.
 B. C_L includes probe and jig capacitance.

Figure 2. Test Circuit, Switching Times, and Voltage Waveforms

PARAMETER MEASUREMENT INFORMATION

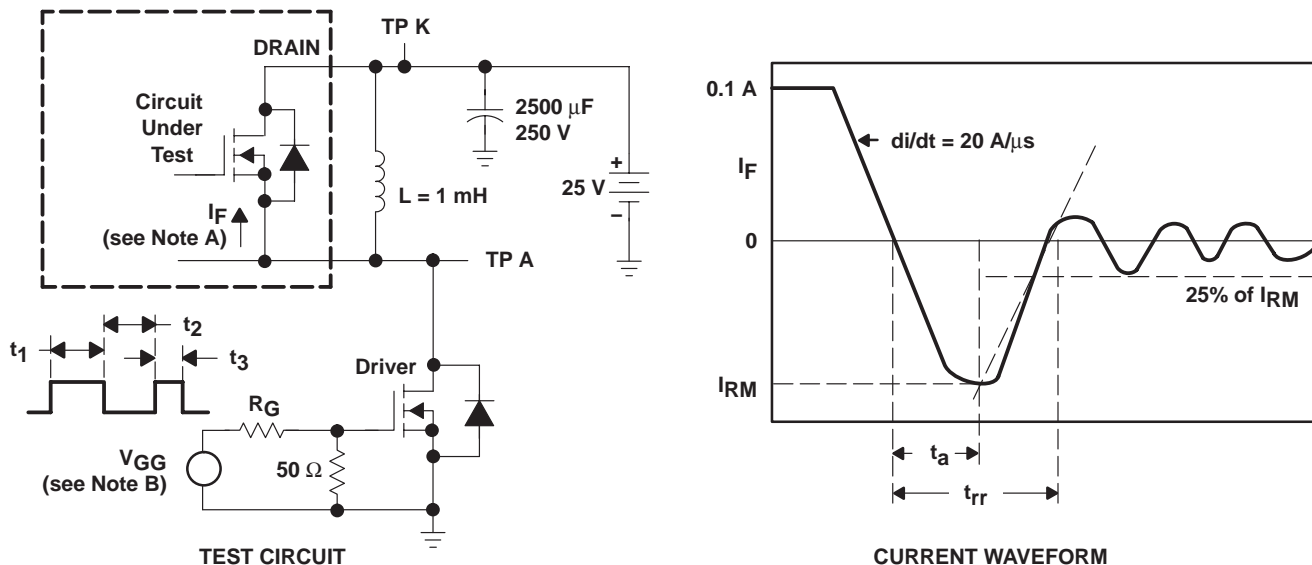

- NOTES: A. The DRAIN terminal under test is connected to the TP K test point. All other terminals are connected together and connected to the TP A test point.
 B. The V_{GG} amplitude and R_G are adjusted for $di/dt = 20 \text{ A}/\mu\text{s}$. A V_{GG} double-pulse train is used to set $I_F = 0.1 \text{ A}$, where $t_1 = 10 \mu\text{s}$, $t_2 = 7 \mu\text{s}$, and $t_3 = 3 \mu\text{s}$.

Figure 3. Reverse-Recovery-Current Test Circuit and Waveforms of Source-to-Drain Diode

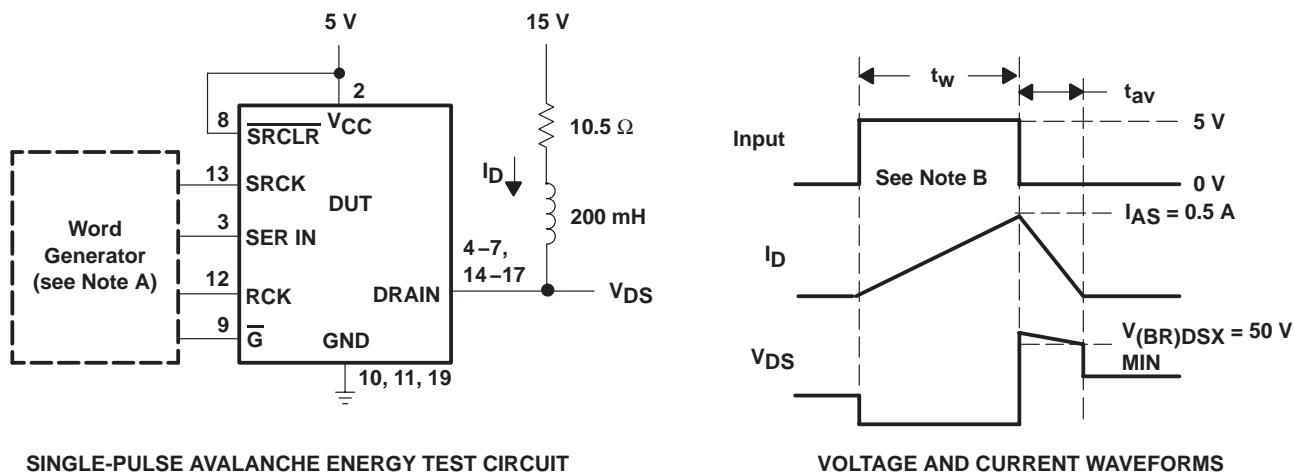

- NOTES: A. The word generator has the following characteristics: $t_r \leq 10 \text{ ns}$, $t_f \leq 10 \text{ ns}$, $Z_0 = 50 \Omega$.
 B. Input pulse duration, t_w , is increased until peak current $I_{AS} = 0.5 \text{ A}$.
 Energy test level is defined as $E_{AS} = I_{AS} \times V_{(BR)DSX} \times t_{AV}/2 = 30 \text{ mJ}$.

Figure 4. Single-Pulse Avalanche Energy Test Circuit and Waveforms

TPIC6B596 POWER LOGIC 8-BIT SHIFT REGISTER

SLIS095A – MARCH 2000 – REVISED MAY 2005

TYPICAL CHARACTERISTICS

PEAK AVALANCHE CURRENT
vs
TIME DURATION OF AVALANCHE

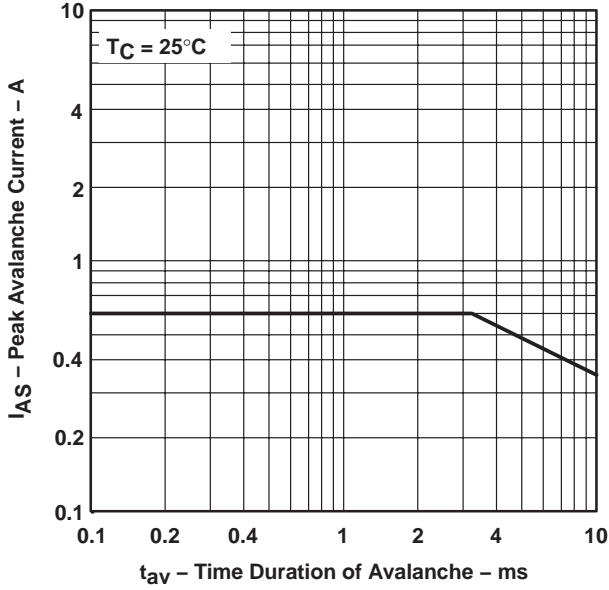

Figure 5

SUPPLY CURRENT
vs
FREQUENCY

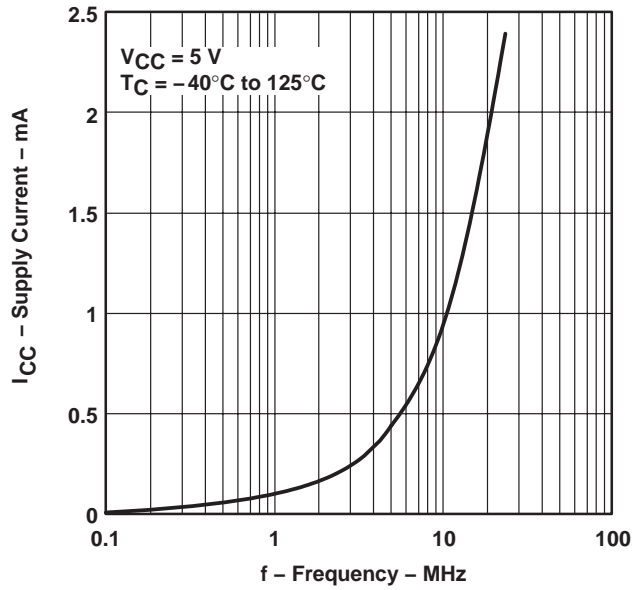

Figure 6

DRAIN-TO-SOURCE ON-STATE RESISTANCE
vs
DRAIN CURRENT

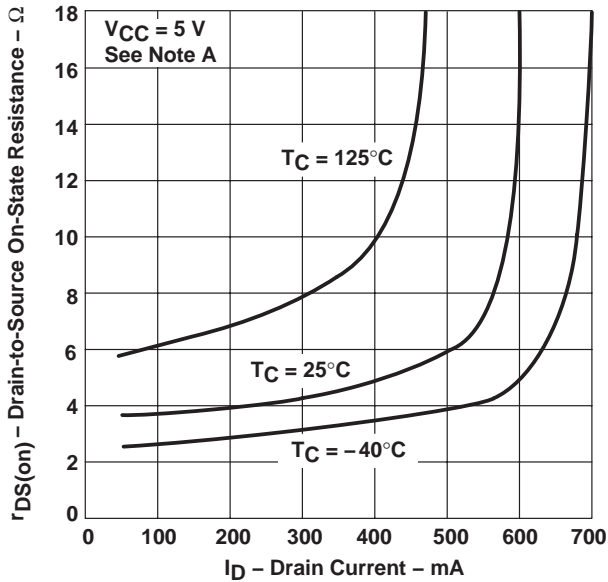

Figure 7

STATIC DRAIN-TO-SOURCE ON-STATE RESISTANCE
vs
LOGIC SUPPLY VOLTAGE

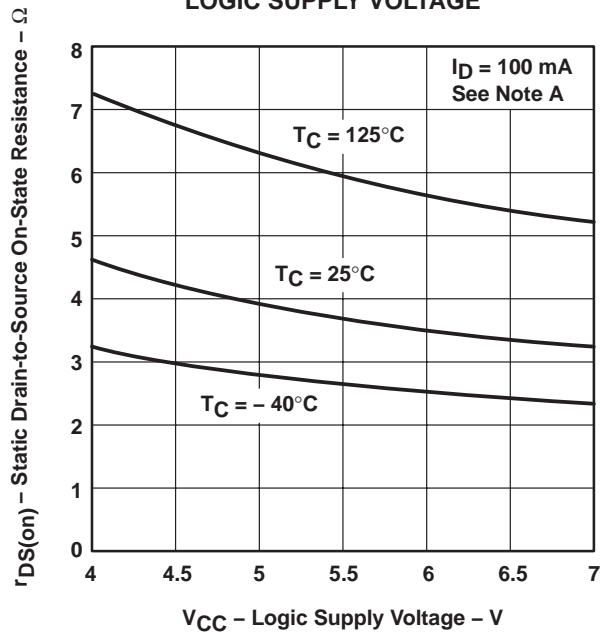

Figure 8

TYPICAL CHARACTERISTICS

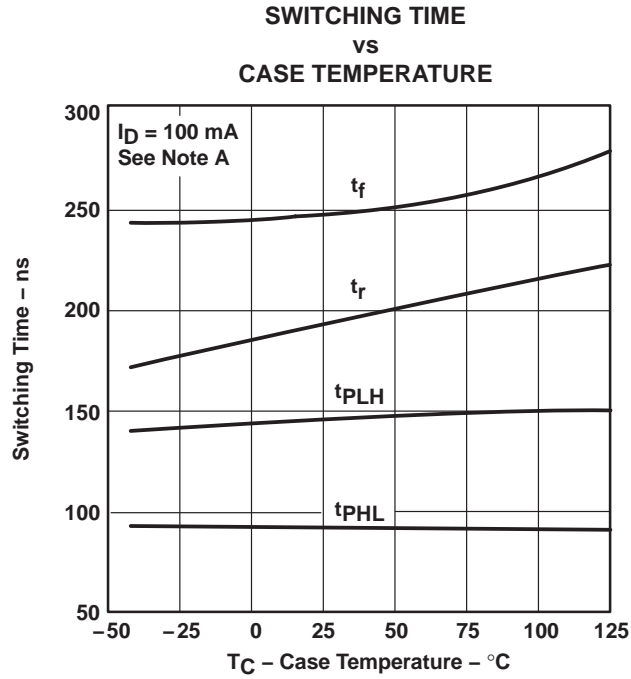

Figure 9

NOTE A: Technique should limit $T_J - T_C$ to 10°C maximum.

TPIC6B596 POWER LOGIC 8-BIT SHIFT REGISTER

SLIS095A – MARCH 2000 – REVISED MAY 2005

THERMAL INFORMATION

MAXIMUM CONTINUOUS
DRAIN CURRENT OF EACH OUTPUT
vs
NUMBER OF OUTPUTS CONDUCTING
SIMULTANEOUSLY

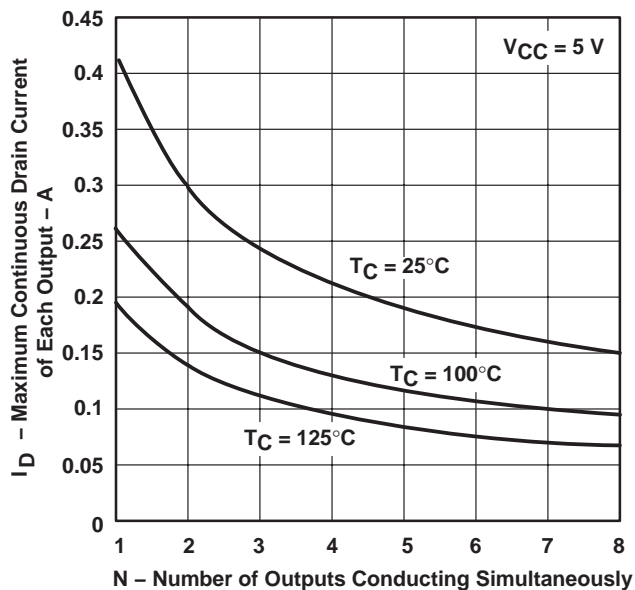

Figure 10

MAXIMUM PEAK DRAIN CURRENT
OF EACH OUTPUT
vs
NUMBER OF OUTPUTS CONDUCTING
SIMULTANEOUSLY

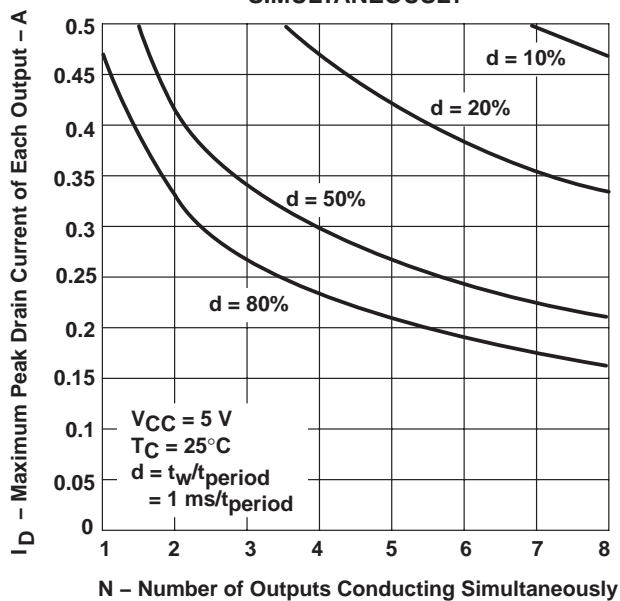

Figure 11

Revision History

DATE	REV	PAGE	SECTION	DESCRIPTION
5/18/05	A	5	Figure 1	Changed SRCLR timing diagram
3/2000	*			Original reversion

NOTE: Page numbers for previous revisions may differ from page numbers in the current version.

PACKAGING INFORMATION

Orderable Device	Status (1)	Package Type	Package Drawing	Pins	Package Qty	Eco Plan (2)	Lead/Ball Finish	MSL Peak Temp (3)	Op Temp (°C)	Top-Side Markings (4)	Samples
TPIC6B596DW	ACTIVE	SOIC	DW	20	25	Green (RoHS & no Sb/Br)	CU NIPDAU	Level-1-260C-UNLIM	-40 to 125	TPIC6B596	Samples
TPIC6B596DWG4	ACTIVE	SOIC	DW	20	25	Green (RoHS & no Sb/Br)	CU NIPDAU	Level-1-260C-UNLIM		TPIC6B596	Samples
TPIC6B596DWR	ACTIVE	SOIC	DW	20	2000	Green (RoHS & no Sb/Br)	CU NIPDAU	Level-1-260C-UNLIM	-40 to 125	TPIC6B596	Samples
TPIC6B596DWRG4	ACTIVE	SOIC	DW	20	2000	Green (RoHS & no Sb/Br)	CU NIPDAU	Level-1-260C-UNLIM		TPIC6B596	Samples
TPIC6B596N	ACTIVE	PDIP	N	20	20	Pb-Free (RoHS)	CU NIPDAU	N / A for Pkg Type	-40 to 125	TPIC6B596N	Samples

(1) The marketing status values are defined as follows:

ACTIVE: Product device recommended for new designs.

LIFEBUY: TI has announced that the device will be discontinued, and a lifetime-buy period is in effect.

NRND: Not recommended for new designs. Device is in production to support existing customers, but TI does not recommend using this part in a new design.

PREVIEW: Device has been announced but is not in production. Samples may or may not be available.

OBSOLETE: TI has discontinued the production of the device.

(2) Eco Plan - The planned eco-friendly classification: Pb-Free (RoHS), Pb-Free (RoHS Exempt), or Green (RoHS & no Sb/Br) - please check <http://www.ti.com/productcontent> for the latest availability information and additional product content details.

TBD: The Pb-Free/Green conversion plan has not been defined.

Pb-Free (RoHS): TI's terms "Lead-Free" or "Pb-Free" mean semiconductor products that are compatible with the current RoHS requirements for all 6 substances, including the requirement that lead not exceed 0.1% by weight in homogeneous materials. Where designed to be soldered at high temperatures, TI Pb-Free products are suitable for use in specified lead-free processes.

Pb-Free (RoHS Exempt): This component has a RoHS exemption for either 1) lead-based flip-chip solder bumps used between the die and package, or 2) lead-based die adhesive used between the die and leadframe. The component is otherwise considered Pb-Free (RoHS compatible) as defined above.

Green (RoHS & no Sb/Br): TI defines "Green" to mean Pb-Free (RoHS compatible), and free of Bromine (Br) and Antimony (Sb) based flame retardants (Br or Sb do not exceed 0.1% by weight in homogeneous material)

(3) MSL, Peak Temp. -- The Moisture Sensitivity Level rating according to the JEDEC industry standard classifications, and peak solder temperature.

(4) Multiple Top-Side Markings will be inside parentheses. Only one Top-Side Marking contained in parentheses and separated by a "~" will appear on a device. If a line is indented then it is a continuation of the previous line and the two combined represent the entire Top-Side Marking for that device.

Important Information and Disclaimer: The information provided on this page represents TI's knowledge and belief as of the date that it is provided. TI bases its knowledge and belief on information provided by third parties, and makes no representation or warranty as to the accuracy of such information. Efforts are underway to better integrate information from third parties. TI has taken and continues to take reasonable steps to provide representative and accurate information but may not have conducted destructive testing or chemical analysis on incoming materials and chemicals. TI and TI suppliers consider certain information to be proprietary, and thus CAS numbers and other limited information may not be available for release.

In no event shall TI's liability arising out of such information exceed the total purchase price of the TI part(s) at issue in this document sold by TI to Customer on an annual basis.

TAPE AND REEL INFORMATION



QUADRANT ASSIGNMENTS FOR PIN 1 ORIENTATION IN TAPE



*All dimensions are nominal

Device	Package Type	Package Drawing	Pins	SPQ	Reel Diameter (mm)	Reel Width W1 (mm)	A0 (mm)	B0 (mm)	K0 (mm)	P1 (mm)	W (mm)	Pin1 Quadrant
TPIC6B596DWR	SOIC	DW	20	2000	330.0	24.4	10.8	13.3	2.7	12.0	24.0	Q1
TPIC6B596DWRG4	SOIC	DW	20	2000	330.0	24.4	10.8	13.3	2.7	12.0	24.0	Q1

TAPE AND REEL BOX DIMENSIONS

*All dimensions are nominal

Device	Package Type	Package Drawing	Pins	SPQ	Length (mm)	Width (mm)	Height (mm)
TPIC6B596DWR	SOIC	DW	20	2000	350.0	350.0	43.0
TPIC6B596DWRG4	SOIC	DW	20	2000	350.0	350.0	43.0

N (R-PDIP-T**)

PLASTIC DUAL-IN-LINE PACKAGE

16 PINS SHOWN



- NOTES:
- A. All linear dimensions are in inches (millimeters).
 - B. This drawing is subject to change without notice.
 - Falls within JEDEC MS-001, except 18 and 20 pin minimum body length (Dim A).
 - The 20 pin end lead shoulder width is a vendor option, either half or full width.

DW0020A



PACKAGE OUTLINE

SOIC - 2.65 mm max height

SOIC



4220724/A 05/2016

NOTES:

1. All linear dimensions are in millimeters. Dimensions in parenthesis are for reference only. Dimensioning and tolerancing per ASME Y14.5M.
2. This drawing is subject to change without notice.
3. This dimension does not include mold flash, protrusions, or gate burrs. Mold flash, protrusions, or gate burrs shall not exceed 0.15 mm per side.
4. This dimension does not include interlead flash. Interlead flash shall not exceed 0.43 mm per side.
5. Reference JEDEC registration MS-013.

EXAMPLE BOARD LAYOUT

DW0020A

SOIC - 2.65 mm max height

SOIC



LAND PATTERN EXAMPLE
SCALE:6X



SOLDER MASK DETAILS

4220724/A 05/2016

NOTES: (continued)

- 6. Publication IPC-7351 may have alternate designs.
- 7. Solder mask tolerances between and around signal pads can vary based on board fabrication site.

EXAMPLE STENCIL DESIGN

DW0020A

SOIC - 2.65 mm max height

SOIC



SOLDER PASTE EXAMPLE
BASED ON 0.125 mm THICK STENCIL
SCALE:6X

4220724/A 05/2016

NOTES: (continued)

8. Laser cutting apertures with trapezoidal walls and rounded corners may offer better paste release. IPC-7525 may have alternate design recommendations.
9. Board assembly site may have different recommendations for stencil design.

IMPORTANT NOTICE AND DISCLAIMER

TI PROVIDES TECHNICAL AND RELIABILITY DATA (INCLUDING DATASHEETS), DESIGN RESOURCES (INCLUDING REFERENCE DESIGNS), APPLICATION OR OTHER DESIGN ADVICE, WEB TOOLS, SAFETY INFORMATION, AND OTHER RESOURCES "AS IS" AND WITH ALL FAULTS, AND DISCLAIMS ALL WARRANTIES, EXPRESS AND IMPLIED, INCLUDING WITHOUT LIMITATION ANY IMPLIED WARRANTIES OF MERCHANTABILITY, FITNESS FOR A PARTICULAR PURPOSE OR NON-INFRINGEMENT OF THIRD PARTY INTELLECTUAL PROPERTY RIGHTS.

These resources are intended for skilled developers designing with TI products. You are solely responsible for (1) selecting the appropriate TI products for your application, (2) designing, validating and testing your application, and (3) ensuring your application meets applicable standards, and any other safety, security, or other requirements. These resources are subject to change without notice. TI grants you permission to use these resources only for development of an application that uses the TI products described in the resource. Other reproduction and display of these resources is prohibited. No license is granted to any other TI intellectual property right or to any third party intellectual property right. TI disclaims responsibility for, and you will fully indemnify TI and its representatives against, any claims, damages, costs, losses, and liabilities arising out of your use of these resources.

TI's products are provided subject to TI's Terms of Sale (www.ti.com/legal/termsofsale.html) or other applicable terms available either on ti.com or provided in conjunction with such TI products. TI's provision of these resources does not expand or otherwise alter TI's applicable warranties or warranty disclaimers for TI products.

Mailing Address: Texas Instruments, Post Office Box 655303, Dallas, Texas 75265
Copyright © 2019, Texas Instruments Incorporated

Looking for pricing, stock, or lifecycle information?

Click below to explore more details on WIN SOURCE:

 [View TPIC6B596N](#) on WIN SOURCE

 [Texas Instruments](#) Information

Optimize Your Supply Chain with WIN SOURCE Solutions

-  Global Sourcing Solution
-  Obsolete Management
-  Cost Control Management
-  Shortage Management
-  Alternative Solution
-  Excess Inventory Management