



**THE DATASHEET OF  
IR3087MPBF**



***XPHASE™* PHASE IC WITH *OPTI-PHASE™*, OVP, AND OVERTEMP DETECT**

**DESCRIPTION**

The IR3087 Phase IC combined with an IR *XPhase™* Control IC provides a full featured and flexible way to implement power solutions for the latest high performance CPUs and ASICs. The “Control” IC provides overall system control and interfaces with any number of “Phase” ICs which each drive and monitor a single phase of a multiphase converter. The *XPhase™* architecture results in a power supply that is smaller, less expensive, and easier to design while providing higher efficiency than conventional approaches.

The IR3087 with *Opti-Phase™* is intended for applications demanding increased efficiency under medium to light load conditions. Both gate drivers will drive low at a programmable output current threshold. This effectively disconnects the phase from the load eliminating power losses due to switching and circulating currents.

**FEATURES**

- 2.5A Average Gate Drive Current
- Loss-Less Inductor Current Sense
- Internal Inductor DCR Temperature Compensation
- Programmable Phase Delay
- Programmable Feed-Forward Voltage Mode PWM Ramp
- Sub 100ns Minimum Pulse Width supports 1MHz per-phase operation
- Current Sense Amplifier drives a single wire Average Current Share Bus
- Current Share Amplifier reduces PWM Ramp slope to ensure sharing between phases
- *Body Braking™* disables Synchronous MOSFET for improved transient response and prevents negative output voltage at converter turn-off
- *Opti-Phase™* reduces the number of phases for improved light to medium load efficiency
- OVP comparator with 150ns response
- Programmable Phase Over-Temperature Detection
- Small thermally enhanced 20L MLPQ package

**APPLICATION CIRCUIT**

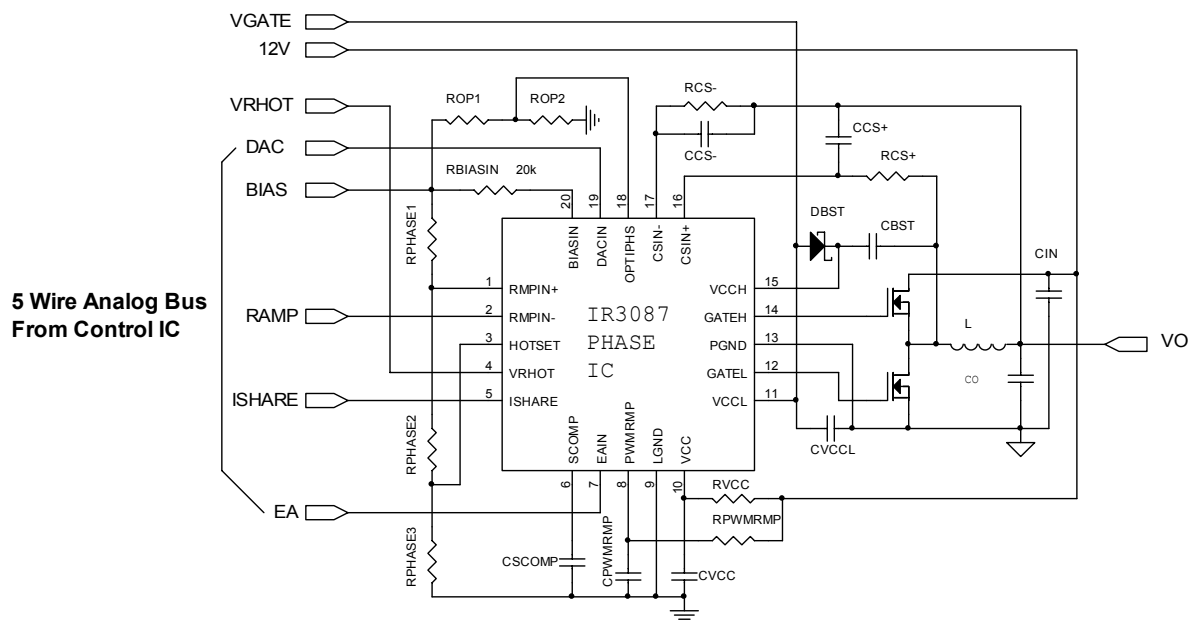

**ORDERING INFORMATION**

Device	Order Quantity
IR3087MTRPbF	3000 per reel
IR3087MPbF	100 piece strips

**ABSOLUTE MAXIMUM RATINGS**

Operating Junction Temperature.....150°C  
 Storage Temperature Range.....-65°C to 150°C  
 ESD Rating.....HBM Class 1C JEDEC standard

PIN #	PIN NAME	V <sub>MAX</sub>	V <sub>MIN</sub>	I <sub>SOURCE</sub>	I <sub>SINK</sub>
1	RMPIN+	20V	-0.3V	1mA	1mA
2	RMPIN-	20V	-0.3V	1mA	1mA
3	HOTSET	20V	-0.3V	1mA	1mA
4	VRHOT	20V	-0.3V	1mA	30mA
5	ISHARE	20V	-0.3V	5mA	5mA
6	SCOMP	20V	-0.3V	1mA	1mA
7	EAIN	20V	-0.3V	1mA	1mA
8	PWMRMP	20V	-0.3V	1mA	20mA
9	LGND	n/a	n/a	50mA	n/a
10	VCC	24V	-0.3V	n/a	50mA
11	VCCL	27V	-0.3V	n/a	3A for 100ns, 200mA DC
12	GATEL	27V	-0.3V DC, -2V for 100ns	3A for 100ns, 200mA DC	3A for 100ns, 200mA DC
13	PGND	0.3V	-0.3V	3A for 100ns, 200mA DC	n/a
14	GATEH	30V	-0.3V DC, -2V for 100ns	3A for 100ns, 200mA DC	3A for 100ns, 200mA DC
15	VCCH	30V	-0.3V	n/a	3A for 100ns, 200mA DC
16	CSIN+	20V	-0.3V	1mA	1mA
17	CSIN-	20V	-0.3V	1mA	1mA
18	OPTIPHS	20V	-0.3V	1mA	1mA
19	DACIN	20V	-0.3V	1mA	1mA
20	BIASIN	20V	-0.3V	1mA	1mA

**ELECTRICAL SPECIFICATIONS**

Unless otherwise specified, these specifications apply over:  $8.4V \leq V_{CC} \leq 21V$ ,  $6V \leq V_{CCH} \leq 28V$ ,  $6V \leq V_{CCL} \leq 14V$ , and  $0^{\circ}C \leq T_J \leq 125^{\circ}C$ ,  $C_{GATEH} = 3.3nF$ ,  $C_{GATEL} = 6.8nF$

PARAMETER	TEST CONDITION	MIN	TYP	MAX	UNIT
<b>Gate Drivers</b>					
GATEH Rise Time	VCCH = 12V, Measure 2V to 9V transition time		22	50	ns
GATEH Fall Time	VCCH = 12V, Measure 9V to 2V transition time		22	50	ns
GATEL Rise Time	VCCL = 12V, Measure 2V to 9V transition time		50	75	ns
GATEL Fall Time	VCCL = 12V, Measure 9V to 2V transition time		50	75	ns
GATEL low to GATEH high delay	VCCH = VCCL = 12V, Measure the time from GATEL falling to 1V to GATEH rising to 1V	10	25	50	ns
GATEH low to GATEL high delay	VCCH = VCCL = 12V, Measure the time from GATEH falling to 1V to GATEL rising to 1V	10	25	50	ns
Disable Pull-Down Current	Force GATEH or GATEL = 2V with BIASIN = 0V	15	25	40	$\mu A$
<b>Current Sense Amplifier</b>					
CSIN+ Bias Current		-0.5	-0.25	0	$\mu A$
CSIN- Bias Current		-1	-0.4	0	$\mu A$
Input Offset Voltage	CSIN+ = CSIN- = DACIN. Measure input referred offset from DACIN	-3	0.5	5	mV
Gain at $T_J = 25^{\circ}C$		32	34	36	V/V
Gain at $T_J = 125^{\circ}C$		27	29	31	V/V
Slew Rate	Current Sense Amplifier output is an internal node. Slew rate at the ISHARE pin will be set by the internal 10k $\Omega$ resistor and any stray external capacitance		12.5		V/ $\mu s$
Differential Input Range		-20		100	mV
Common Mode Input Range		0		4	V
Rout at $T_J = 25^{\circ}C$		7.9	10.5	13.1	k $\Omega$
Rout at $T_J = 125^{\circ}C$		9.3	12.4	15.5	k $\Omega$
<b>Ramp Discharge Clamp</b>					
Clamp Voltage	Force I(PWMRMP) = 500 $\mu A$ . Measure V(PWMRMP) – V(DACIN)	-10	5	20	mV
Clamp Discharge Current		4	8		mA

PARAMETER	TEST CONDITION	MIN	TYP	MAX	UNIT
<b>Ramp Comparator</b>					
Input Offset Voltage		20	40	80	mV
Hysteresis	Note 1	-10	0	10	mV
RMPIN+, RMPIN- Bias Current		-1	0	1	μA
Propagation Delay	VCCH = 12V. Measure time from RMPIN input (50mV overdrive) to GATEL transition to <11V.	100	150	240	ns
<b>PWM Comparator</b>					
PWM Comparator Input Offset Voltage		-5	5	15	mV
EAIN & PWMRMP Bias Current	Clamp and Current Share Adjust OFF	-1	-0.4	1	μA
Propagation Delay	VCCH = 12V. Measure time from PWMRMP input (50mV overdrive) to GATEH transition to < 11V.		70	150	ns
Common Mode Input Range	Exceeding the Common Mode input range results in 100% duty cycle			5	V
<b>Share Adjust Error Amplifier</b>					
Input Offset Voltage		10	20	30	mV
Input Voltage Range	EAIN – PWMRMP, Note 1	-3.5		3.5	V
PWMRMP Adjust Current		4	8		mA
Transconductance	I(PWMRMP) = 3.5mA, Note 1	0.9	1.6	2.3	A/V
SCOMP Source/Sink Current	Note 1	20	30	40	μA
SCOMP Activation Voltage	Amount SCOMP must increase from its minimum voltage until the Ramp Slope Adjust current equals = 10μA	60	150	300	mV
PWMRMP Min Voltage	I(PWMRMP) = 500μA	150	225	350	mV
<b>0% Duty Cycle Comparator</b>					
Threshold Voltage	Compare to V(DACIN)	86	88	92	%
Propagation Delay	VCCL = 12V. Measure time from EAIN < 0.9 x V(DACIN) (200mV overdrive) to GATEL transition to < 11V. Note 1.		100	150	ns
<b>Opti-Phase™ Comparator</b>					
Threshold Voltage	VDACIN = 0.8V, V(OPTIPHS) = 0.25V	-5	35	75	mV
Threshold Voltage	VDACIN = 0.8V, V(OPTIPHS) = 1.0V	-55	10	90	mV
Threshold Voltage	VDACIN = 0.8V, V(OPTIPHS) = 2.0V	-135	-25	105	mV
Threshold Voltage	VDACIN = 1.2V, V(OPTIPHS) = 0.25V	-10	45	90	mV
Threshold Voltage	VDACIN = 1.2V, V(OPTIPHS) = 1.0V	-55	25	105	mV
Threshold Voltage	VDACIN = 1.2V, V(OPTIPHS) = 2.0V	-130	0	135	mV
Threshold Voltage	VDACIN = 1.6V, V(OPTIPHS) = 0.25V	-15	50	115	mV
Threshold Voltage	VDACIN = 1.6V, V(OPTIPHS) = 1.0V	-50	40	120	mV
Threshold Voltage	VDACIN = 1.6V, V(OPTIPHS) = 2.0V	-125	10	155	mV
Propagation Delay			200		ns
OPTIPHS Bias Current		-1	-0.2	1	μA
Disable Comparator Threshold	V(BIASIN) – V(OPTIPHS)	100	400	750	mV

PARAMETER	TEST CONDITION	MIN	TYP	MAX	UNIT
<b>OVP Comparator</b>					
Threshold Voltage	Compare to V(DACIN)	100	125	160	mV
Propagation Delay	VCCL = 12V. Measure time from CSIN > V(DACIN) (200mV overdrive) to GATEL transition to <11V.		150	250	ns
<b>General</b>					
VCC Supply Current			10	14	mA
VCCL Supply Current			2.5	5	mA
VCCH Supply Current	$4V \leq V_{CCH} \leq 14V$		5.5	8	mA
	$14V \leq V_{CCH} \leq 28V$		6.5	10	mA
BIASIN Bias Current		-5	-2.5	2	$\mu A$
DACIN Bias Current		-2	-1	1	$\mu A$
<b>VRHOT Comparator</b>					
HOTSET Bias Current		-6	-4	-2	$\mu A$
Output Voltage	$I(VRHOT) = 29mA$		300	400	mV
VRHOT Leakage Current	$V(VRHOT) = 5.5V$		0	10	$\mu A$
Threshold Hysteresis	$T_J \geq 85^\circ C$	3.0	7.0	11.0	$^\circ C$
		<b>MIN</b>	<b>TYP</b>	<b>MAX</b>	
Threshold Voltage	$T_J \geq 85^\circ C$	$4.73mV/^\circ C \times T_J + 1.36V$	$4.73mV/^\circ C \times T_J + 1.46V$	$4.73mV/^\circ C \times T_J + 1.56V$	V

**Note 1:** Guaranteed by design, but not tested in production

**PIN DESCRIPTION**

PIN#	PIN SYMBOL	PIN DESCRIPTION
1	RMPIN+	Non-inverting input to Ramp Comparator
2	RMPIN-	Inverting input to Ramp Comparator
3	HOTSET	Inverting input to VRHOT comparator. Connect resistor divider from VBIAS to LGND to program VRHOT threshold. Diode or thermistor may be substituted for lower resistor for enhanced/remote temperature sensing.
4	VRHOT	Open Collector output of the VRHOT comparator which drives low if IC junction temperature exceeds the user programmable limit. Connect external pull-up.
5	ISHARE	Output of the Current Sense Amplifier and input to the Share Adjust Error Amplifier. Voltage on this pin is equal to $V(DACIN) + 34 * [V(CSIN+) - V(CSIN-)]$ . Connecting ISHARE pins together creates a Share Bus enabling current sharing between Phase ICs. The Share bus is also used by the Control IC for voltage positioning and Over-Current protection.
6	SCOMP	Compensation for the Current Share control loop. Connect a capacitor to ground to set the control loop's bandwidth.
7	EAIN	PWM comparator input from the error amplifier output of Control IC. Both Gate Driver outputs drive low if the voltage on this pin is less than 88% of V(DACIN).
8	PWMRMP	PWM comparator ramp input. Connect a resistor from this pin to the converter input voltage and a capacitor to LGND to program the PWM ramp.
9	LGND	Signal ground and IC substrate connection
10	VCC	Power for internal circuitry
11	VCCL	Power for Low-Side Gate Driver
12	GATEL	Low-Side Gate Driver Output and input to GATEH non-overlap comparator
13	PGND	Return for Gate Drivers
14	GATEH	High-Side Gate Driver Output and input to GATEL non-overlap comparator
15	VCCH	Power for High-Side Gate Driver
16	CSIN+	Non-inverting input to the Current Sense Amplifier
17	CSIN-	Inverting input to the Current Sense Amplifier and non-inverting input to the OVP comparator
18	OPTIPHS	Input to the <i>Opti-Phase</i> <sup>TM</sup> Comparator. If the voltage on this pin exceeds the voltage on the ISHARE pin minus the voltage on the DACIN pin the GATEX pins will drive low. Connect external resistor divider to BIASIN, OPTIPHS and LGND to program, or connect to BIASIN to disable.
19	DACIN	Reference voltage input from the Control IC and also inverting input to the OVP comparator. Current sensing and PWM operation referenced to this pin.
20	BIASIN	System reference voltage for internal circuitry

**SYSTEM THEORY OF OPERATION**

**XPhase™ Architecture**

The XPhase™ architecture is designed for multiphase interleaved buck converters which are used in applications requiring small size, design flexibility, low voltage, high current and fast transient response. The architecture can control converters of any phase number where flexibility facilitates the design trade-off of multiphase converters. The scalable architecture can be applied to other applications which require high current or multiple output voltages.

As shown in Figure 1, the XPhase™ architecture consists of a Control IC and a scalable array of phase converters each using a single Phase IC. The Control IC communicates with the Phase ICs through a 5-wire analog bus, i.e. bias voltage, phase timing, average current, error amplifier output, and VID voltage. The Control IC incorporates all the system functions, i.e. VID, PWM ramp oscillator, error amplifier, bias voltage, and fault protections etc. The Phase IC implements the functions required by the converter of each phase, i.e. the gate drivers, PWM comparator and latch, over-voltage protection, and current sensing and sharing.

There is no unused or redundant silicon with the XPhase™ architecture compared to others such as a 4 phase controller that can be configured for 2, 3, or 4 phase operation. PCB Layout is easier since the 5 wire bus eliminates the need for point-to-point wiring between the Control IC and each Phase. The critical gate drive and current sense connections are short and local to the Phase ICs. This improves the PCB layout by lowering the parasitic inductance of the gate drive circuits and reducing the noise of the current sense signal.

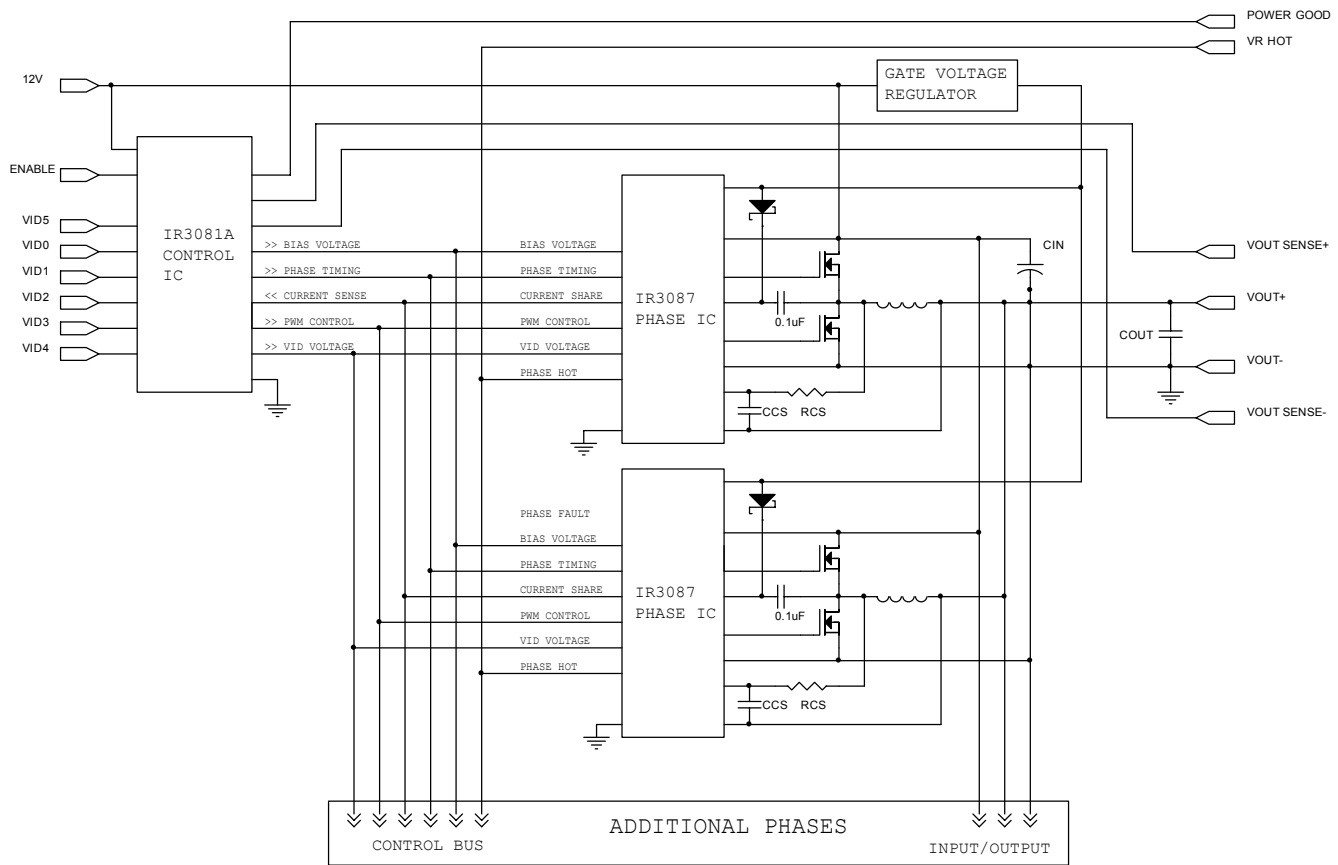

Figure 1. System Block Diagram

**PWM Control Method**

The PWM block diagram of the *XPhase*<sup>TM</sup> architecture is shown in Figure 2. Feed-forward voltage mode control with trailing edge modulation is used. A high-gain wide-bandwidth voltage type error amplifier in the Control IC is used for the voltage control loop. An external RC circuit connected to the input voltage and ground is used to program the slope of the PWM ramp and to provide the feed-forward control at each phase. The PWM ramp slope will change with the input voltage and automatically compensate for changes in the input voltage. The input voltage can change due to variations in the silver box output voltage or due to the wire and PCB-trace voltage drop related to changes in load current.

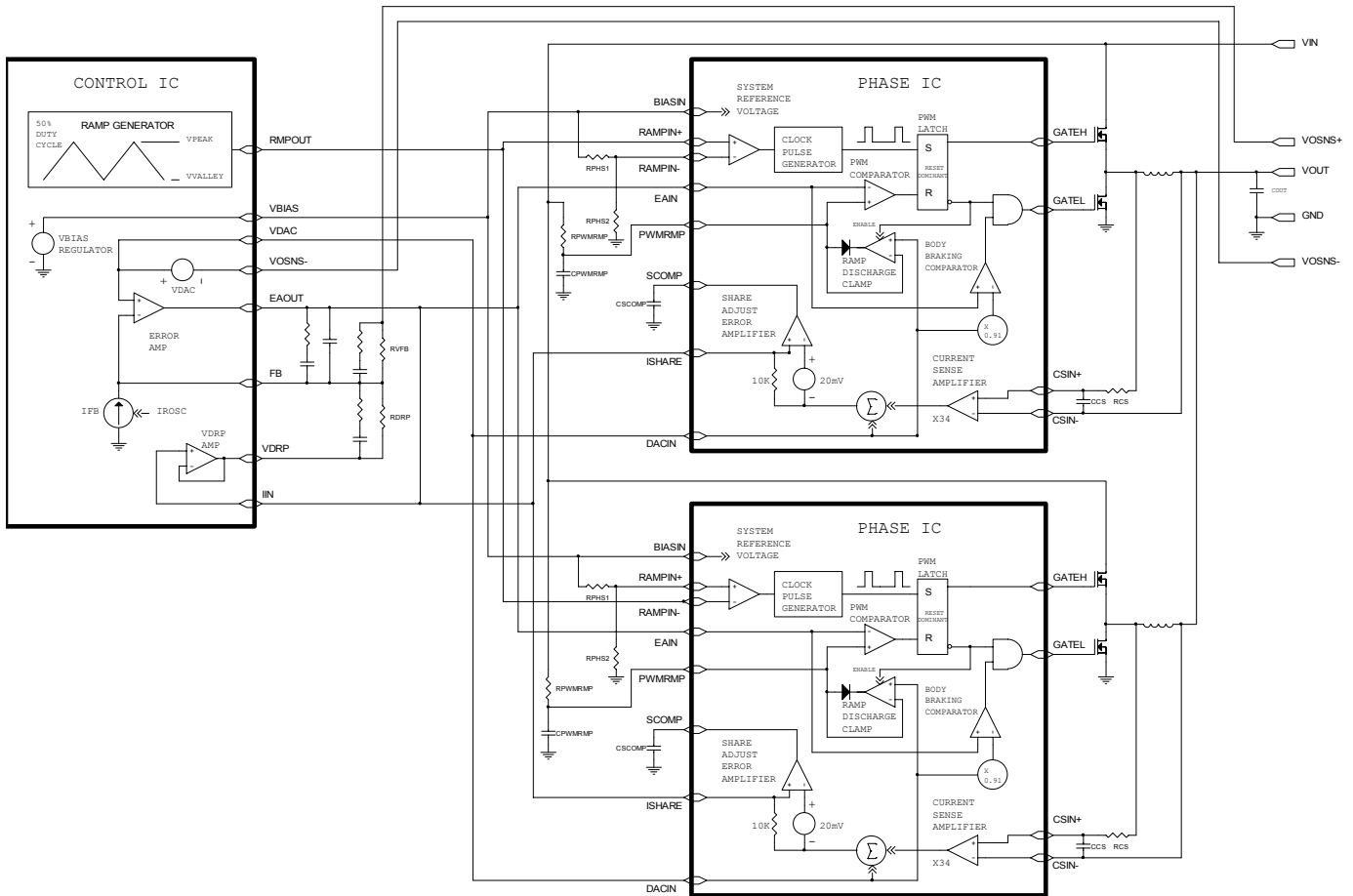

Figure 2. PWM Block Diagram

**Frequency and Phase Timing Control**

An oscillator with programmable frequency is located in the Control IC. The output of the oscillator is a 50% duty cycle triangle waveform with peak and valley voltages of approximately 4.6V and 0.9V respectively. This signal is used to program both the switching frequency and phase timing of the Phase ICs. The Phase IC is programmed by resistor divider RPHS1 and RPHS2 connected between the VBIAS reference voltage and the Phase IC LGND pin. A comparator in the Phase ICs detects the crossing of the oscillator waveform over the voltage generated by the resistor divider and triggers a clock pulse that starts the PWM cycle. The peak and valley voltages track the VBIAS voltage reducing potential Phase IC timing errors. Figure 3 shows the Phase timing for an 8 phase converter. Note that both slopes of the triangle waveform can be used for phase timing by swapping the RMPIN+ and RMPIN- pins, as shown in Figure 2.

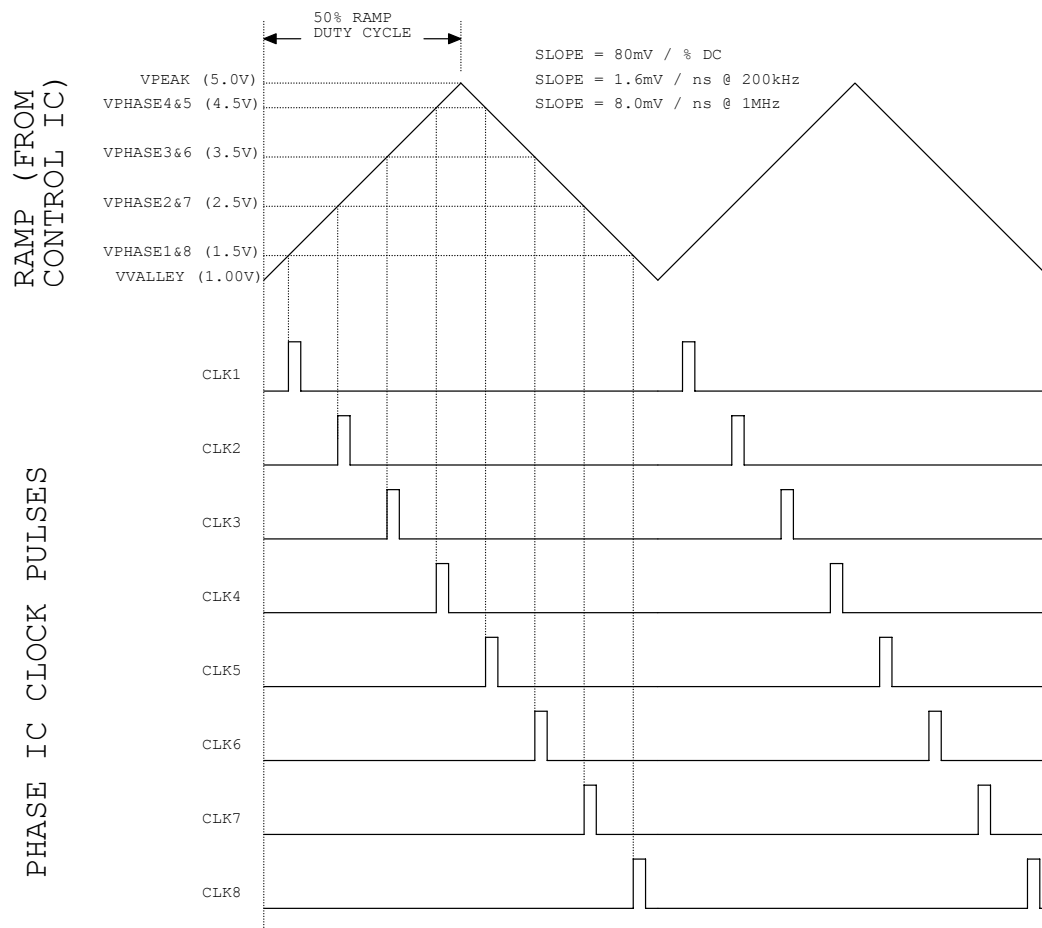

Figure 3. 8 Phase Oscillator Waveforms

### PWM Operation

The PWM comparator is located in the Phase IC. Upon receiving a clock pulse, the PWM latch is set; the PWMRMP voltage begins to increase; the low side driver is turned off, and the high side driver is then turned on after the non-overlap time. When the PWMRMP voltage exceeds the Error Amplifier's output voltage, the PWM latch is reset. This turns off the high side driver and then turns on the low side driver after the non-overlap time; it activates the Ramp Discharge Clamp, which quickly discharges the PWMRMP capacitor to the VDAC voltage of the Control IC until the next clock pulse.

The PWM latch is reset dominant allowing all phases to go to zero duty cycle within a few tens of nanoseconds in response to a load step decrease. Phases can overlap and go to 100% duty cycle in response to a load step increase with turn-on gated by the clock pulses. An Error Amplifier output voltage greater than the common mode input range of the PWM comparator results in 100% duty cycle regardless of the voltage of the PWM ramp. This arrangement guarantees the Error Amplifier is always in control and can demand 0 to 100% duty cycle as required. It also favors response to a load step decrease which is appropriate given the low output to input voltage ratio of most systems. The inductor current will increase much more rapidly than decrease in response to load transients.

This control method is designed to provide "single cycle transient response" where the inductor current changes in response to load transients within a single switching cycle maximizing the effectiveness of the power train and minimizing the output capacitor requirements. An additional advantage is that differences in ground or input voltage at the phases have no effect on operation since the PWM ramps are referenced to VDAC.

Figure 4 depicts PWM operating waveforms under various conditions.

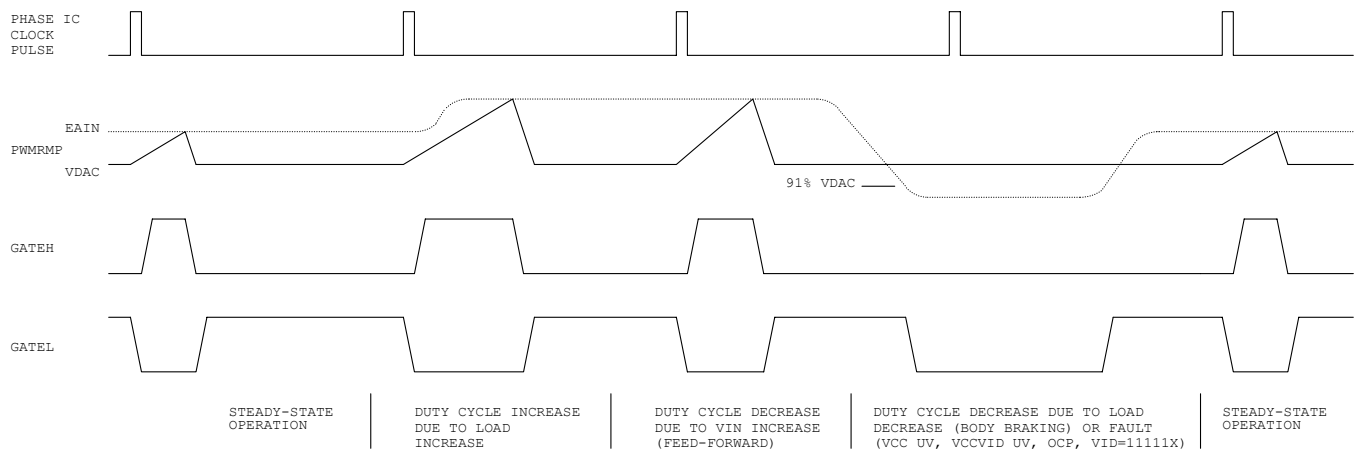

Figure 4. PWM Operating Waveforms

### Body Braking™

In a conventional synchronous buck converter, the minimum time required to reduce the current in the inductor in response to a load step decrease is;

$$T_{SLEW} = \frac{L * (I_{MAX} - I_{MIN})}{V_O}$$

The slew rate of the inductor current can be significantly increased by turning off the synchronous rectifier in response to a load step decrease. The switch node voltage is then forced to decrease until conduction of the synchronous rectifier's body diode occurs. This increases the voltage across the inductor from  $V_{out}$  to  $V_{out} + V_{BODYDIODE}$ . The minimum time required to reduce the current in the inductor in response to a load transient decrease is now;

$$T_{SLEW} = \frac{L * (I_{MAX} - I_{MIN})}{V_O + V_{BODYDIODE}}$$

Since the voltage drop in the body diode is often higher than output voltage, the inductor current slew rate can be increased by 2X or more. This patent pending technique is referred to as "body braking" and is accomplished through the "0% Duty Cycle Comparator" located in the Phase IC. If the Error Amplifier's output voltage drops below 88% of the VDAC voltage this comparator turns off the low side gate driver.

### Lossless Average Inductor Current Sensing

Inductor current can be sensed by connecting a resistor and a capacitor in parallel with the inductor and measuring the voltage across the capacitor, as shown in Figure 5. The equation of the sensing network is,

$$v_C(s) = v_L(s) \frac{1}{1 + sR_{CS}C_{CS}} = i_L(s) \frac{R_L + sL}{1 + sR_{CS}C_{CS}}$$

Usually the resistor  $R_{CS}$  and capacitor  $C_{CS}$  are chosen so that the time constant of  $R_{CS}$  and  $C_{CS}$  equals the time constant of the inductor which is the inductance  $L$  over the inductor DCR ( $R_L$ ). If the two time constants match, the voltage across  $C_{CS}$  is proportional to the current through  $L$ , and the sense circuit can be treated as if only a sense resistor with the value of  $R_L$  was used. The mismatch of the time constants does not affect the measurement of inductor DC current, but affects the AC component of the inductor current.

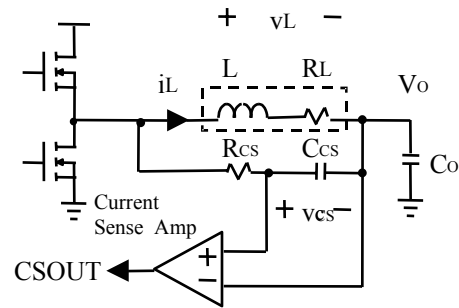

Figure 5. Inductor Current Sensing and Current Sense Amplifier

The advantage of sensing the inductor current versus high side or low side sensing is that actual output current being delivered to the load is obtained rather than peak or sampled information about the switch currents. The output voltage can be positioned to meet a load line based on real time information. Except for a sense resistor in series with inductor, this is the only sense method that can support a single cycle transient response. Other methods provide no information during either load increase (low side sensing) or load decrease (high side sensing).

An additional problem associated with peak or valley current mode control for voltage positioning is that they suffer from peak-to-average errors. These errors will show in many ways but one example is the effect of frequency variation. If the frequency of a particular unit is 10% low, the peak to peak inductor current will be 10% larger and the output impedance of the converter will drop by about 10%. Variations in inductance, current sense amplifier bandwidth, PWM prop delay, any added slope compensation, input voltage, and output voltage are all additional sources of peak-to-average errors.

### Current Sense Amplifier

This is a high speed differential current sense amplifier, as shown in Figure 5. Its gain decreases with increasing temperature and is nominally 34 at 25°C and 29 at 125°C (-1470 ppm/°C). This reduction of gain tends to compensate the 3850 ppm/°C increase in inductor DCR. Since in most designs the Phase IC junction is hotter than the inductor these two effects tend to cancel such that no additional temperature compensation of the load line is required.

The current sense amplifier can accept positive differential input up to 100mV and negative up to -20mV before clipping. The output of the current sense amplifier is summed with the DAC voltage and sent to the Control IC and other Phases through an on-chip 10KΩ resistor connected to the ISHARE pin. The ISHARE pins of all the phases are tied together and the voltage on the share bus represents the average current being delivered to the load and is used by the Control IC for voltage positioning and current limit protection.

### Average Current Share Loop

Current sharing between phases of the converter is achieved by the average current share loop in each Phase IC. The output of the current sense amplifier is compared with the share bus less a 20mV offset. If current in a phase is smaller than the average current, the share adjust error amplifier of the phase will activate a current source that reduces the slope of its PWM ramp thereby increasing its duty cycle and output current. The crossover frequency of the current share loop can be programmed with a capacitor at the SCOMP pin so that the share loop does not interact with the output voltage loop.

**IR3087 THEORY OF OPERATION**

**Block Diagram**

The Block diagram of the IR3087 is shown in Figure 6, and specific features are discussed in the following sections.

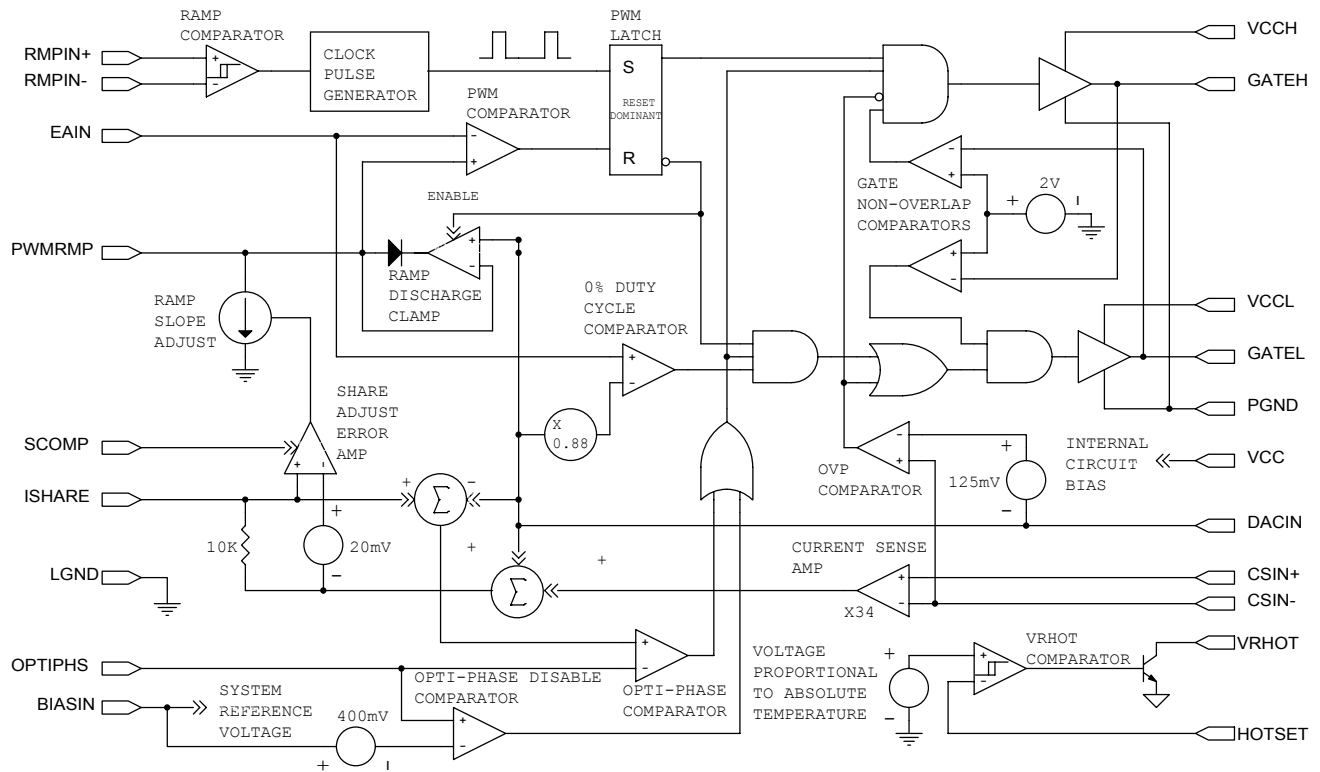

Figure 6. IR3087 Block Diagram

**Tri-State Gate Drivers**

The gate drivers can deliver up to 3A peak current. An adaptive non-overlap circuit monitors the voltage on the GATEH and GATEL pins to prevent MOSFET shoot-through current while minimizing body diode conduction.

An Enable signal is provided by the Control IC to the Phase IC without the addition of a dedicated signal line. The Error Amplifier output of the Control IC drives low in response to any fault condition such as input under voltage or output overload. The IR3087 0% duty cycle comparator detects this and drives both gate outputs low. This tri-state operation prevents negative inductor current and negative output voltage during power-down.

The Gate Drivers revert to a high impedance “off” state if VCCL and VCCH supply voltages are below the normal operating range. An 80kΩ resistor is connected across the GATEH/GATEL and PGND pins to prevent the GATEH/GATEL voltage from rising due to leakage or other cause under these conditions.

**Over Voltage Protection (OVP)**

The IR3087 includes over-voltage protection that turns on the low side MOSFET to protect the load in the event of a shorted high-side MOSFET or connection of the converter output to an excessive output voltage. A comparator monitors the voltage at the CSIN- pin which is usually connected directly to the converter output. If the voltage exceeds the DACIN voltage plus 125mV typical (100mV minimum and 160mV maximum), the GATEL pin drives high. The OVP circuit overrides the normal PWM operation and will fully turn-on the low side MOSFET within approximately 150ns. The low side MOSFET will remain ON until the over-voltage condition ceases.

When designing for OVP the overall system must be considered. In many cases the over-current protection of the AC-DC or DC-DC converter supplying the multiphase converter will be triggered thus providing effective protection without damage as long as all PCB traces and components are sized to handle the worst-case maximum current. If this is not possible a fuse can be added in the input supply to the multiphase converter. One scenario to be careful of is where the input voltage to the multiphase converter may be pulled below the level where the ICs can provide adequate voltage to the low side MOSFET thus defeating OVP.

Dynamic changes in the VID code to a lower output voltage may trigger OVP. For example; a 250mV decrease in output voltage combined with a light load condition will cause the low side MOSFETs to turn on and interfere with Body Braking™. This will not cause a problem, however, as Body Braking™ will resume once the output voltage is less than 125mV above the VID voltage.

Since CSIN- pin is also used as the inductor current sensing input, it is usually connected to the local converter output, which may be far away from the load of the multiphase converter. Excessive distribution impedance between the converter and load may trigger OVP during normal operation. If the voltage drop across the distribution impedance exceeds the minimum OVP comparator threshold of 100mV plus VID offset and voltage positioning, the IR3087 can not be used. The IR3088A Phase IC without OVP should be used instead in applications with excessive distribution impedance and very small or no AVP. For example, a converter having 25mV of VID offset, 125mV of AVP at full load, and 100mV of drop in the distribution path at full load would be OK, since  $100\text{mV} + 25\text{mV} + 125\text{mV} = 250\text{mV}$  which is greater than the 100mV drop. However, a converter having 25mV of VID offset, no AVP, and 130mV of drop in the distribution path would require IR3088A, since  $100\text{mV} + 25\text{mV} + 0\text{mV} = 125\text{mV}$  which is smaller than the 130mV drop.

Converter with higher output voltage than VID voltage may also trigger OVP during normal operation, and IR3088A should be used to replace IR3087.

### Thermal Monitoring (VRHOT)

The IR3087 senses its own die temperature and produces a voltage at the input of the VRHOT comparator that is proportional to temperature. An external resistor divider connected from VBIAS to the HOTSET pin and ground can be used to program the thermal trip point of the VRHOT comparator. The VRHOT pin is an open-collector output and should be pulled up to a voltage source through a resistor. If the thermal trip point is reached the VRHOT output drives low.

### Opti-Phase™

The number of phases chosen for a particular design is based upon meeting thermal requirements and minimizing the number of input and output capacitors at the maximum output current. At currents less than the maximum efficiency will increase if less phases are used. Turning off phases as the output current decreases increases efficiency by eliminating the gate charging losses, MOSFET switching losses, and circulating currents in the MOSFETS and output inductors. For each unique design there will be an optimal point where phases should be turned off, one after another, to achieve the maximum efficiency over the entire output current range.

The IR3087 implements patent pending *Opti-Phase*™ control allowing programmable shutdown of phases as a function of converter output current. The *Opti-Phase*™ comparator monitors the voltage on the ISHARE pin less the voltage on the DACIN pin. This voltage provides a direct indication of converter output current. A resistor divider connected between the BIASIN, OPTIPHS, and LGND pins programs the threshold of the *Opti-Phase*™ comparator. If the converter output current drops below the programmed level the GATEH and GATEL pins will both drive low turning off the MOSFETs and causing the inductor current to begin to decay. The output voltage will begin to sag causing the Control IC to immediately increase the duty cycle of the remaining phase(s) to compensate. The voltage on the ISHARE will remain constant as it represents the converter output current rather than the current in the individual phases.

*Opti-Phase*™ can be disabled by connecting the OPTIPHS pin to the BIASIN pin. This must be done on at least one phase IC per converter to ensure operation under zero load conditions.

**APPLICATIONS INFORMATION**

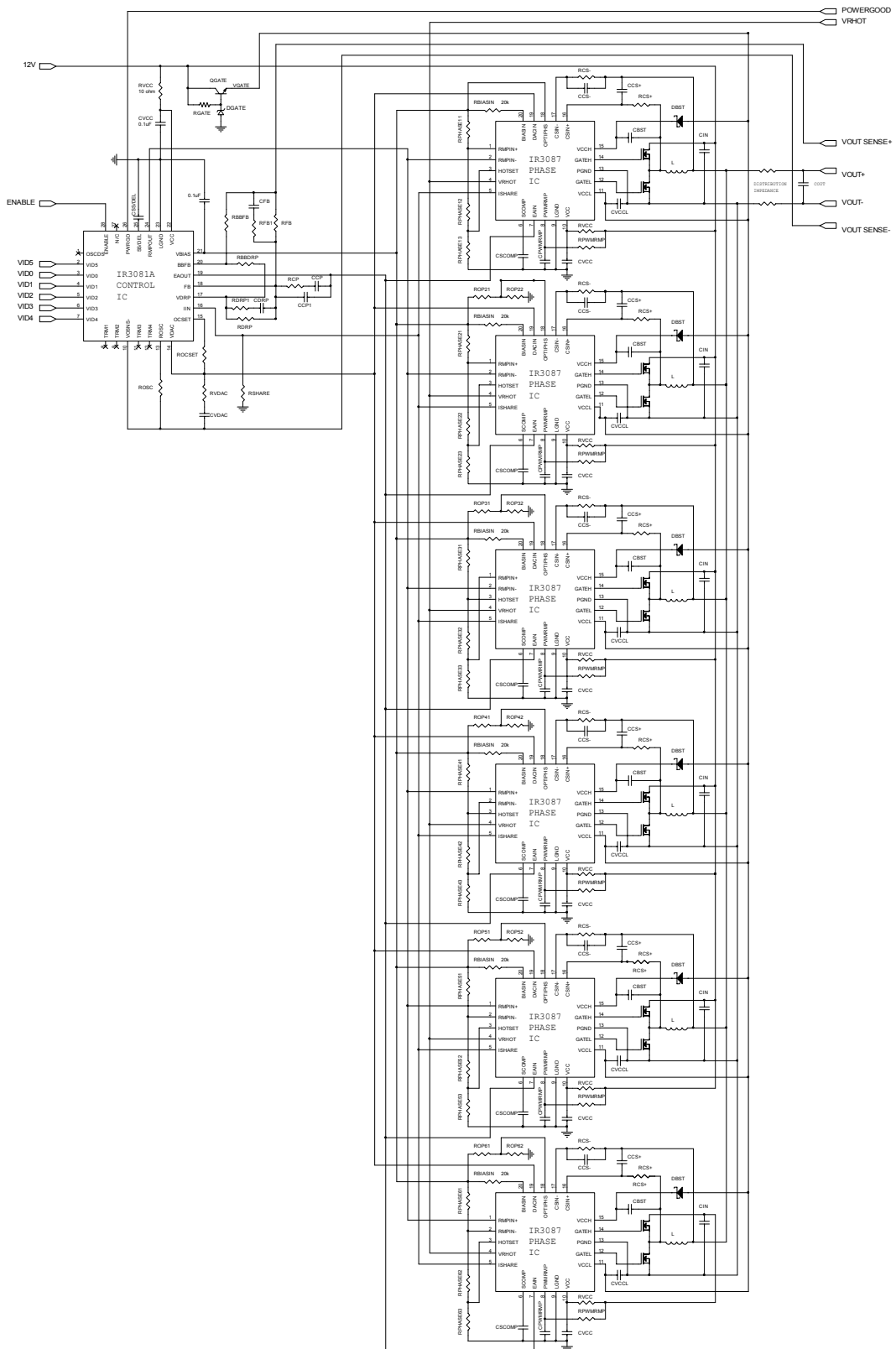

Figure 7. 6 Phase IR3081A/3087 VRM / EVRD 10 Converter

## DESIGN PROCEDURES - IR3081A AND IR3087 CHIPSET

### IR3081A EXTERNAL COMPONENTS

#### Oscillator Resistor $R_{osc}$

The oscillator of IR3081A generates a triangle waveform to synchronize the phase ICs, and the switching frequency of the each phase converter equals the oscillator frequency, which is set by the external resistor  $R_{osc}$  according to the curve in Figure 13.

#### Soft Start Capacitor $C_{SS/DEL}$

Because the capacitor  $C_{SS/DEL}$  programs four different time parameters, i.e. soft start delay time, soft start time, over-current latch delay time, and power good delay time, they should be considered together while choosing  $C_{SS/DEL}$ .

The  $SS/DEL$  pin voltage controls the slew rate of the converter output voltage, as shown in Figure 10. After the  $ENABLE$  pin voltage rises above 0.6V, there is a soft-start delay time  $t_{SSDEL}$ , after which the error amplifier output is released to allow the soft start. The soft start time  $t_{ss}$  represents the time during which converter voltage rises from zero to  $V_O$ .  $t_{ss}$  can be programmed by an external capacitor, which is determined by Equation (1).

$$C_{SS/DEL} = \frac{I_{CHG} * t_{SS}}{V_O} = \frac{70 * 10^{-6} * t_{SS}}{V_O} \quad (1)$$

Once  $C_{SS/DEL}$  is chosen, the soft start delay time  $t_{SSDEL}$ , the over-current fault latch delay time  $t_{OCDEL}$ , and the delay time  $t_{VccPG}$  from output voltage ( $V_O$ ) in regulation to Power Good are fixed and shown in Equations (2), (3) and (4) respectively.

$$t_{SSDEL} = \frac{C_{SS/DEL} * 1.3}{I_{CHG}} = \frac{C_{SS/DEL} * 1.3}{70 * 10^{-6}} \quad (2)$$

$$t_{OCDEL} = \frac{C_{SS/DEL} * 0.115}{I_{OCDISCHG}} = \frac{C_{SS/DEL} * 0.115}{40 * 10^{-6}} \quad (3)$$

$$t_{VccPG} = \frac{C_{SS/DEL} * (3.8 - 0.065 - V_O - 1.3)}{I_{CHG}} = \frac{C_{SS/DEL} * (3.735 - V_O - 1.3)}{70 * 10^{-6}} \quad (4)$$

#### VDAC Slew Rate Programming Capacitor $C_{VDAC}$ and Resistor $R_{VDAC}$

The slew rate of VDAC down-slope  $SR_{DOWN}$  can be programmed by the external capacitor  $C_{VDAC}$  as defined in Equation (5), where  $I_{SINK}$  is the sink current of VDAC pin as shown in Figure 15. The resistor  $R_{VDAC}$  is used to compensate VDAC circuit and is determined by Equation (6). The slew rate of VDAC up-slope  $SR_{UP}$  is proportional to that of VDAC down-slope and is given by Equation (7), where  $I_{SOURCE}$  is the source current of VDAC pin as shown in Figure 15.

$$C_{VDAC} = \frac{I_{SINK}}{SR_{DOWN}} \quad (5)$$

$$R_{VDAC} = 0.5 + \frac{3.2 * 10^{-15}}{C_{VDAC}^2} \quad (6)$$

$$SR_{UP} = \frac{I_{SOURCE}}{C_{VDAC}} \quad (7)$$

### Over Current Setting Resistor *ROCSET*

The inductor DC resistance is utilized to sense the inductor current. The copper wire of inductor has a constant temperature coefficient of 3850 ppm/°C, and therefore the maximum inductor DCR can be calculated from Equation (8), where  $R_{L\_MAX}$  and  $R_{L\_ROOM}$  are the inductor DCR at maximum temperature  $T_{L\_MAX}$  and room temperature  $T_{ROOM}$  respectively.

$$R_{L\_MAX} = R_{L\_ROOM} * [1 + 3850 * 10^{-6} * (T_{L\_MAX} - T_{ROOM})] \quad (8)$$

The current sense amplifier gain of IR3087 decreases with temperature at the rate of 1470 ppm/°C, which compensates part of the inductor DCR increase. The phase IC die temperature is only a couple of degrees Celsius higher than the PCB temperature due to the low thermal impedance of MLPQ package. The minimum current sense amplifier gain at the maximum phase IC temperature  $T_{IC\_MAX}$  is calculated from Equation (9).

$$G_{CS\_MIN} = G_{CS\_ROOM} * [1 - 1470 * 10^{-6} * (T_{IC\_MAX} - T_{ROOM})] \quad (9)$$

The total input offset voltage ( $V_{CS\_TOFST}$ ) of current sense amplifier in phase ICs is the sum of input offset ( $V_{CS\_OFST}$ ) of the amplifier itself and that created by the amplifier input bias currents flowing through the current sense resistors  $R_{CS+}$  and  $R_{CS-}$ .

$$V_{CS\_TOFST} = V_{CS\_OFST} + I_{CSIN+} * R_{CS+} - I_{CSIN-} * R_{CS-} \quad (10)$$

The over current limit is set by the external resistor  $ROCSET$  as defined in Equation (11), where  $I_{LIMIT}$  is the required over current limit.  $I_{OCSET}$ , the bias current of  $OCSET$  pin, changes with switching frequency setting resistor  $ROSC$  and is determined by the curve in Figure 14.  $K_P$  is the ratio of inductor peak current over average current in each phase and is calculated from Equation (12).

$$R_{OCSET} = \left[ \frac{I_{LIMIT}}{n} * R_{L\_MAX} * (1 + K_P) + V_{CS\_TOFST} \right] * G_{CS\_MIN} / I_{OCSET} \quad (11)$$

$$K_P = \frac{(V_I - V_O) * V_O / (L * V_I * f_{SW} * 2)}{I_O / n} \quad (12)$$

### No Load Output Voltage Setting Resistor *RFB* and Adaptive Voltage Positioning Resistor *RDRP*

A resistor between FB pin and the converter output is used to create output voltage offset  $V_{O\_NLOFST}$ , which is the difference between  $V_{DAC}$  voltage and output voltage at no load condition. Adaptive voltage positioning further lowers the converter voltage by  $R_O * I_O$ , where  $R_O$  is the required output impedance of the converter.

$R_{FB}$  is not only determined by  $I_{FB}$ , the current flowing out of FB pin as shown in Figure 14, but also affected by the adaptive voltage positioning resistor  $R_{DRP}$  and total input offset voltage of current sense amplifiers.  $R_{FB}$  and  $R_{DRP}$  are determined by (13) and (14) respectively.

$$R_{FB} = \frac{R_{L\_MAX} * V_{O\_NLOFST} - V_{CS\_TOFST} * n * R_O}{I_{FB} * R_{L\_MAX}} \quad (13)$$

$$R_{DRP} = \frac{R_{FB} * R_{L\_MAX} * G_{CS\_MIN}}{n * R_O} \quad (14)$$

### Body Braking™ Related Resistors *RBBFB* and *RBBDRP*

The body braking™ during Dynamic VID can be disabled by connecting  $BBFB$  pin to ground. If the feature is enabled, Resistors  $R_{BBFB}$  and  $R_{BBDRP}$  are needed to restore the feedback voltage of the error amplifier after Dynamic VID step down. Usually  $R_{BBFB}$  and  $R_{BBDRP}$  are chosen to match  $R_{FB}$  and  $R_{DRP}$  respectively.

## IR3087 EXTERNAL COMPONENTS

### PWM Ramp Resistor $R_{PWMRMP}$ and Capacitor $C_{PWMRMP}$

PWM ramp is generated by connecting the resistor  $R_{PWMRMP}$  between a voltage source and  $PWMRMP$  pin as well as the capacitor  $C_{PWMRMP}$  between  $PWMRMP$  and  $LGND$ . Choose the desired PWM ramp magnitude  $V_{PWMRMP}$  and the capacitor  $C_{PWMRMP}$  in the range of 100pF and 470pF, and then calculate the resistor  $R_{PWMRMP}$  from Equation (15). To achieve feed-forward voltage mode control, the resistor  $R_{PWMRMP}$  should be connected to the input of the converter.

$$R_{PWMRMP} = \frac{V_O}{V_{IN} * f_{SW} * C_{PWMRMP} * [\ln(V_{IN} - V_{DAC}) - \ln(V_{IN} - V_{DAC} - V_{PWMRMP})]} \quad (15)$$

### Inductor Current Sensing Capacitor $C_{CS+}$ and Resistors $R_{CS+}$ and $R_{CS-}$

The DC resistance of the inductor is utilized to sense the inductor current. Usually the resistor  $R_{CS+}$  and capacitor  $C_{CS+}$  in parallel with the inductor are chosen to match the time constant of the inductor, and therefore the voltage across the capacitor  $C_{CS+}$  represents the inductor current. If the two time constants are not the same, the AC component of the capacitor voltage is different from that of the real inductor current. The time constant mismatch does not affect the average current sharing among the multiple phases, but affect the current signal  $ISHARE$  as well as the output voltage during the load current transient if adaptive voltage positioning is adopted.

Measure the inductance  $L$  and the inductor DC resistance  $R_L$ . Pre-select the capacitor  $C_{CS+}$  and calculate  $R_{CS+}$  as follows.

$$R_{CS+} = \frac{L/R_L}{C_{CS+}} \quad (16)$$

The bias current flowing out of the non-inverting input of the current sense amplifier creates a voltage drop across  $R_{CS+}$ , which is equivalent to an input offset voltage of the current sense amplifier. The offset affects the accuracy of converter current signal  $ISHARE$  as well as the accuracy of the converter output voltage if adaptive voltage positioning is adopted. To reduce the offset voltage, a resistor  $R_{CS-}$  should be added between the amplifier inverting input and the converter output. The resistor  $R_{CS-}$  is determined by the ratio of the bias current from the non-inverting input and the bias current from the inverting input.

$$R_{CS-} = \frac{I_{CSIN+}}{I_{CSIN-}} * R_{CS+} \quad (17)$$

If  $R_{CS-}$  is not used,  $R_{CS+}$  should be chosen so that the offset voltage is small enough. Usually  $R_{CS+}$  should be less than 2 k $\Omega$  and therefore a larger  $C_{CS+}$  value is needed.

### Over Temperature Setting Resistors $R_{HOTSET1}$ and $R_{HOTSET2}$

The threshold voltage of  $VRHOT$  comparator is proportional to the die temperature  $T_J$  ( $^{\circ}C$ ) of phase IC. Determine the relationship between the die temperature of phase IC and the temperature of the power converter according to the power loss, PCB layout and airflow etc, and then calculate  $HOTSET$  threshold voltage corresponding to the allowed maximum temperature from Equation (18).

$$V_{HOTSET} = 4.73 * 10^{-3} * T_J + 1.46 \quad (18)$$

There are two ways to set the over temperature threshold, central setting and local setting. In the central setting, only one resistor divider is used, and the setting voltage is connected to  $HOTSET$  pins of all the phase ICs. To reduce the influence of noise on the accuracy of over temperature setting, a 0.1uF capacitor should be placed next to  $HOTSET$  pin of each phase IC. In the local setting, a resistor divider per phase is needed, and the setting voltage is connected to  $HOTSET$  pin of each phase. The 0.1uF decoupling capacitor is not necessary. Use  $V_{BIAS}$  as the reference voltage. If  $R_{HOTSET1}$  is pre-selected,  $R_{HOTSET2}$  can be calculated as follows.

$$R_{HOTSET2} = \frac{R_{HOTSET1} * V_{HOTSET}}{V_{BIAS} - V_{HOTSET}} \quad (19)$$

### Phase Delay Timing Resistors $R_{PHASE1}$ and $R_{PHASE2}$

The phase delay of the interleaved multiphase converter is programmed by the resistor divider connected at RMPIN+ or RMPIN- depending on which slope of the oscillator ramp is used for the phase delay programming of phase IC, as shown in Figure 3.

If the upslope is used, RMPIN+ pin of the phase IC should be connected to RMPOUT pin of the control IC and RMPIN- pin should be connected to the resistor divider. When RMPOUT voltage is above the trip voltage at RMPIN- pin, the PWM latch is set. GATEL becomes low, and GATEH becomes high after the non-overlap time.

If down slope is used, RMPIN- pin of the phase IC should be connected to RMPOUT pin of the control IC and RMPIN+ pin should be connected to the resistor divider. When RMPOUT voltage is below the trip voltage at RMPIN- pin, the PWM latch is set. GATEL becomes low, and GATEH becomes high after the non-overlap time.

Use VBIAS voltage as the reference for the resistor divider since the oscillator ramp magnitude from control IC tracks VBIAS voltage. Try to avoid both edges of the oscillator ramp for better noise immunity. Determine the ratio of the programming resistors corresponding to the desired switching frequencies and phase numbers. If the resistor  $R_{PHASEx1}$  is pre-selected, the resistor  $R_{PHASEx2}$  is determined as:

$$R_{PHASEx2} = \frac{RA_{PHASEx} * R_{PHASEx1}}{1 - RA_{PHASEx}} \quad (20)$$

### Combined Over Temperature and Phase Delay Setting Resistors $R_{PHASE1}$ , $R_{PHASE2}$ and $R_{PHASE3}$

The over temperature setting resistor divider can be combined with the phase delay resistor divider to save one resistor per phase.

Calculate the HOTSET threshold voltage  $V_{HOTSET}$  corresponding to the allowed maximum temperature from Equation (18). If the over temperature setting voltage is lower than the phase delay setting voltage,  $V_{BIAS} * R_{PHASEx}$ , connect RMPIN+ or RMPIN- pin between  $R_{PHASEx1}$  and  $R_{PHASEx2}$ , and connect HOTSET pin between  $R_{PHASEx2}$  and  $R_{PHASEx3}$ . Pre-select  $R_{PHASEx1}$ ,

$$R_{PHASEx2} = \frac{(RA_{PHASEx} * V_{BIAS} - V_{HOTSET}) * R_{PHASEx1}}{V_{BIAS} * (1 - RA_{PHASEx})} \quad (21)$$

$$R_{PHASEx3} = \frac{V_{HOTSET} * R_{PHASEx1}}{V_{BIAS} * (1 - RA_{PHASEx})} \quad (22)$$

If the over temperature setting voltage is higher than the phase delay setting voltage,  $V_{BIAS} * R_{PHASEx}$ , connect HOTSET pin between  $R_{PHASEx1}$  and  $R_{PHASEx2}$ . and connect RMPIN+ or RMPIN- between  $R_{PHASEx2}$  and  $R_{PHASEx3}$ . Pre-select  $R_{PHASEx1}$ ,

$$R_{PHASEx2} = \frac{(V_{HOTSET} - RA_{PHASEx} * V_{BIAS}) * R_{PHASEx1}}{V_{BIAS} - V_{HOTSET}} \quad (23)$$

$$R_{PHASEx3} = \frac{RA_{PHASEx} * V_{BIAS} * R_{PHASEx1}}{V_{BIAS} - V_{HOTSET}} \quad (24)$$

### Bootstrap Capacitor $CBST$

Depending on the duty cycle and gate drive current of the phase IC, a 0.1uF to 1uF capacitor is needed for the bootstrap circuit.

### Decoupling Capacitors for Phase IC

0.1uF-1uF decoupling capacitors are required at VCC and VCCL pins of phase ICs.

**Opti-Phase Resistors  $R_{OP1}$  and  $R_{OP2}$**

A resistor divider is used to program OPTIPHS pin voltage, which represents the load current threshold below which the phase is shut down to reduce the switching loss. Pre-select  $R_{OP1}$ , and calculate  $R_{OP2}$  according to Equation (25), where  $I_{O\_OP}$  is the Opti-Phase shedding current threshold.

$$R_{OP2} = \frac{R_{OP1} * [(I_{O\_OP} / n) * R_L + V_{CS\_TOFST}] * G_{CS}}{V_{BLAS} - [(I_{O\_OP} / n) * R_L + V_{CS\_TOFST}] * G_{CS}} \quad (25)$$

The connection of OPTIPHS pin to VBIAS pin disables this function and keeps the phase always on.

**VOLTAGE LOOP COMPENSATION**

The adaptive voltage positioning (AVP) is usually adopted in the computer applications to improve the transient response and reduce the power loss at heavy load. Like current mode control, the adaptive voltage positioning loop introduces extra zero to the voltage loop and splits the double poles of the power stage, which make the voltage loop compensation much easier.

Resistors  $R_{FB}$  and  $R_{DRP}$  are chosen according to Equations (13) and (14), and the selection of compensation types depends on the output capacitors used in the converter. For the applications using Electrolytic, Polymer or AL-Polymer capacitors and running at lower frequency, type II compensation shown in Figure 8(a) is usually enough. While for the applications using ceramic capacitors and running at higher frequency, type III compensation shown in Figure 8(b) is preferred.

For applications where AVP is not required, the compensation is the same as for the regular voltage mode control. For converter using Polymer, AL-Polymer, and ceramic capacitors, which have much higher ESR zero frequency, type III compensation is required as shown in Figure 8(b) with  $R_{DRP}$  and  $C_{DRP}$  removed.

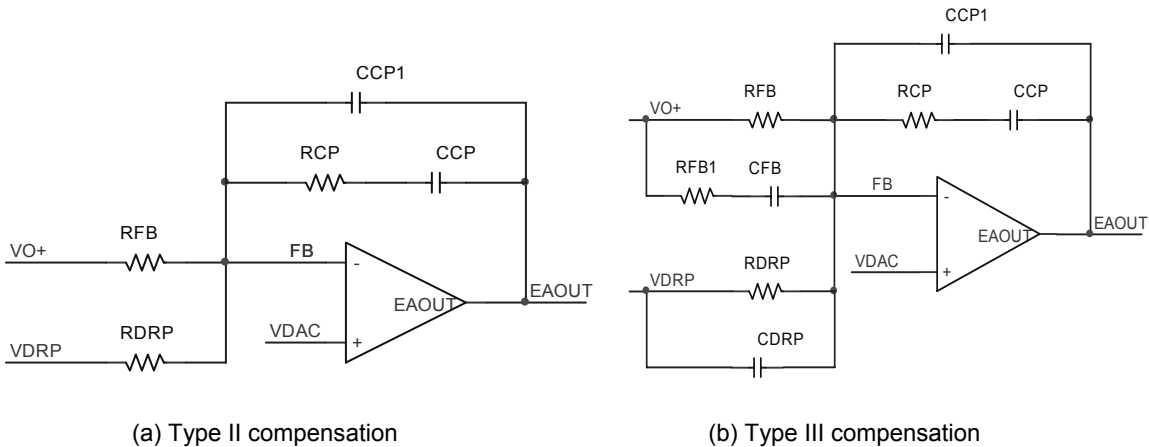

Figure 8. Voltage loop compensation network

### Type II Compensation for AVP Applications

Determine the compensation at no load, the worst case condition. Choose the crossover frequency  $f_c$  between 1/10 and 1/5 of the switching frequency per phase. Assume the time constant of the resistor and capacitor across the output inductors matches that of the inductor, and determine  $R_{CP}$  and  $C_{CP}$  from Equations (26) and (27), where  $L_E$  and  $C_E$  are the equivalent inductance of output inductors and the equivalent capacitance of output capacitors respectively.

$$R_{CP} = \frac{(2\pi * f_c)^2 * L_E * C_E * R_{FB} * V_{PWMRMP}}{V_O * \sqrt{1 + (2\pi * f_c * C * R_C)^2}} \quad (26)$$

$$C_{CP} = \frac{10 * \sqrt{L_E * C_E}}{R_{CP}} \quad (27)$$

$CCP1$  is optional and may be needed in some applications to reduce the jitter caused by the high frequency noise. A ceramic capacitor between 10pF and 220pF is usually enough.

### Type III Compensation for AVP Applications

Determine the compensation at no load, the worst case condition. Assume the time constant of the resistor and capacitor across the output inductors matches that of the inductor, the crossover frequency and phase margin of the voltage loop can be estimated by Equations (28) and (29), where  $R_{LE}$  is the equivalent resistance of inductor DCR. .

$$f_{C1} = \frac{R_{DRP}}{2\pi * C_E * G_{CS} * R_{FB} * R_{LE}} \quad (28)$$

$$\theta_{C1} = 90 - A \tan(0.5) * \frac{180}{\pi} \quad (29)$$

Choose the desired crossover frequency  $f_c$  around  $f_{c1}$  estimated by Equation (28) or choose  $f_c$  between 1/10 and 1/5 of the switching frequency per phase, and select the components to ensure the slope of close loop gain is -20dB/Dec around the crossover frequency. Choose resistor  $R_{FB1}$  according to Equation (30), and determine  $C_{FB}$  and  $R_{DRP}$  from Equations (31) and (32).

$$R_{FB1} = \frac{1}{2} R_{FB} \quad \text{to} \quad R_{FB1} = \frac{2}{3} R_{FB} \quad (30)$$

$$C_{FB} = \frac{1}{4\pi * f_c * R_{FB1}} \quad (31)$$

$$C_{DRP} = \frac{(R_{FB} + R_{FB1}) * C_{FB}}{R_{DRP}} \quad (32)$$

$R_{CP}$  and  $C_{CP}$  have limited effect on the crossover frequency, and are used only to fine tune the crossover frequency and transient load response. Determine  $R_{CP}$  and  $C_{CP}$  from Equations (33) and (34).

$$R_{CP} = \frac{(2\pi * f_c)^2 * L_E * C_E * R_{FB} * V_{PWMRMP}}{V_O} \quad (33)$$

$$C_{CP} = \frac{10 * \sqrt{L_E * C_E}}{R_{CP}} \quad (34)$$

$CCP1$  is optional and may be needed in some applications to reduce the jitter caused by the high frequency noise. A ceramic capacitor between 10pF and 220pF is usually enough.

### Type III Compensation for Non-AVP Applications

Resistor  $R_{FB}$  is chosen according to Equations (13), and resistor  $R_{DRP}$  and capacitor  $C_{DRP}$  are not needed. Choose the crossover frequency  $f_c$  between 1/10 and 1/5 of the switching frequency per phase and select the desired phase margin  $\theta_c$ . Calculate  $K$  factor from Equation (35), and determine the component values based on Equations (36) to (40),

$$K = \tan\left[\frac{\pi}{4} * \left(\frac{\theta_c}{180} + 1.5\right)\right] \quad (35)$$

$$R_{CP} = R_{FB} * \frac{(2\pi * \sqrt{L_E * C_E} * f_c)^2 * V_{PWMRMP}}{V_O * K} \quad (36)$$

$$C_{CP} = \frac{K}{2\pi * f_c * R_{CP}} \quad (37)$$

$$C_{CP1} = \frac{1}{2\pi * f_c * K * R_{CP}} \quad (38)$$

$$C_{FB} = \frac{K}{2\pi * f_c * R_{FB}} \quad (39)$$

$$R_{FB1} = \frac{1}{2\pi * f_c * K * C_{FB}} \quad (40)$$

### CURRENT SHARE LOOP COMPENSATION

The crossover frequency of the current share loop should be at least one decade lower than that of the voltage loop in order to eliminate the interaction between the two loops. A capacitor from SCOMP to ground is usually enough for the share loop compensation. Choose the crossover frequency of current share loop ( $f_{CI}$ ) based on the crossover frequency of voltage loop ( $f_c$ ), and determine the  $C_{SCOMP}$ ,

$$C_{SCOMP} = \frac{0.65 * R_{PWMRMP} * V_I * I_O * G_{CS\_ROOM} * R_{LE} * [1 + 2\pi * f_{CI} * C_E * (V_O / I_O)] * F_{MI}}{V_O * 2\pi * f_{CI} * 1.05 * 10^6} \quad (41)$$

Where  $F_{MI}$  is the PWM gain in the current share loop,

$$F_{MI} = \frac{R_{PWMRMP} * C_{PWMRMP} * f_{SW} * V_{PWMRMP}}{(V_I - V_{PWMRMP} - V_{DAC}) * (V_I - V_{DAC})} \quad (42)$$

## DESIGN EXAMPLE 1 - VRM 10 2U CONVERTER

### SPECIFICATIONS

Input Voltage:  $V_I=12\text{ V}$   
 DAC Voltage:  $V_{DAC}=1.35\text{ V}$   
 No Load Output Voltage Offset:  $V_{O\_NLOFST}=20\text{ mV}$   
 Output Current:  $I_O=105\text{ ADC}$   
 Maximum Output Current:  $I_{OMAX}=120\text{ ADC}$   
 Output Impedance:  $R_O=0.91\text{ m}\Omega$   
 VCC Ready to VCC Power Good Delay:  $t_{VCCPG}=0\text{-}10\text{ mS}$   
 Soft Start Time:  $t_{SS}=2\text{ mS}$   
 Over Current Delay:  $t_{OCDEL}<0.5\text{ mS}$   
 Dynamic VID Down-Slope Slew Rate:  $SR_{DOWN}=2.5\text{ mV/uS}$   
 Over Temperature Threshold:  $T_{PCB}=115\text{ }^\circ\text{C}$

### POWER STAGE

Phase Number:  $n=6$   
 Switching Frequency:  $f_{sw}=400\text{ kHz}$   
 Output Inductors:  $L=220\text{ nH}$ ,  $R_L=0.47\text{ m}\Omega$   
 Output Capacitors: AL-Polymer,  $C=560\text{ uF}$ ,  $R_C=7\text{ m}\Omega$ , Number  $C_n=10$

### IR3081A EXTERNAL COMPONENTS

#### Oscillator Resistor $R_{osc}$

Once the switching frequency is chosen,  $R_{osc}$  can be determined from the curve in Figure 13. For switching frequency of 400kHz per phase, choose  $R_{osc}=30.1\text{ k}\Omega$

#### Soft Start Capacitor $C_{SS/DEL}$

Determine the soft start capacitor from the required soft start time.

$$C_{SS/DEL} = \frac{I_{CHG} * t_{SS}}{V_O} = \frac{70 * 10^{-6} * 2 * 10^{-3}}{1.35 - 20 * 10^{-3}} = 0.1\text{ uF}$$

The soft start delay time is

$$t_{SSDEL} = \frac{C_{SS/DEL} * 1.3}{I_{CHG}} = \frac{0.1 * 10^{-6} * 1.3}{70 * 10^{-6}} = 1.86\text{ mS}$$

The power good delay time is

$$t_{VCCPG} = \frac{C_{SS/DEL} * (3.735 - V_O - 1.3)}{I_{CHG}} = \frac{0.1 * 10^{-6} * (3.735 - 1.33 - 1.3)}{70 * 10^{-6}} = 1.58\text{ ms}$$

Over current delay time is

$$t_{OCDEL} = \frac{C_{SS/DEL} * 0.115}{I_{OCDISCHG}} = \frac{0.1 * 10^{-6} * 0.115}{40 * 10^{-6}} = 0.29\text{ ms}$$

#### VDAC Slew Rate Programming Capacitor $C_{VDAC}$ and Resistor $R_{VDAC}$

From Figure 15, the sink current of VDAC pin corresponding to 400kHz ( $R_{osc}=30.1\text{ k}\Omega$ ) is 76uA. Calculate the VDAC down-slope slew-rate programming capacitor from the required down-slope slew rate.

$$C_{VDAC} = \frac{I_{SINK}}{SR_{DOWN}} = \frac{76 * 10^{-6}}{2.5 * 10^{-3} / 10^{-6}} = 30.4nF, \text{ Choose } C_{VDAC}=33nF$$

Calculate the programming resistor.

$$R_{VDAC} = 0.5 + \frac{3.2 * 10^{-15}}{C_{VDAC}^2} = 0.5 + \frac{3.2 * 10^{-15}}{(33 * 10^{-9})^2} = 3.5\Omega$$

From Figure 15, the source current of VDAC pin is 110uA. The VDAC up-slope slew rate is

$$SR_{UP} = \frac{I_{SOURCE}}{C_{VDAC}} = \frac{110 * 10^{-6}}{33 * 10^{-9}} = 3.3mV / \mu s$$

### Over Current Setting Resistor *ROCSET*

The room temperature is 25°C and the target PCB temperature is 100 °C. The phase IC die temperature is about 1 °C higher than that of phase IC, and the inductor temperature is close to PCB temperature.

Calculate Inductor DC resistance at 100 °C,

$$R_{L\_MAX} = R_{L\_ROOM} * [1 + 3850 * 10^{-6} * (T_{L\_MAX} - T_{ROOM})] = 0.47 * 10^{-3} * [1 + 3850 * 10^{-6} * (100 - 25)] = 0.61m\Omega$$

The current sense amplifier gain is 34 at 25°C, and its gain at 101°C is calculated as,

$$G_{CS\_MIN} = G_{CS\_ROOM} * [1 - 1470 * 10^{-6} * (T_{IC\_MAX} - T_{ROOM})] = 34 * [1 - 1470 * 10^{-6} * (101 - 25)] = 30.2$$

Set the over current limit at 135A. From Figure 14, the bias current of OCSET pin (IOCSET) is 41uA with ROSC=30.1kΩ. The total current sense amplifier input offset voltage is 0.55mV, which includes the offset created by the current sense amplifier input resistor mismatch.

Calculate constant KP, the ratio of inductor peak current over average current in each phase,

$$K_P = \frac{(V_I - V_O) * V_O / (L * V_I * f_{SW} * 2)}{I_{LIMIT} / n} = \frac{(12 - 1.33) * 1.33 / (220 * 10^{-9} * 12 * 400 * 10^3 * 2)}{135 / 6} = 0.3$$

$$R_{OCSET} = \left[ \frac{I_{LIMIT}}{n} * R_{L\_MAX} * (1 + K_P) + V_{CS\_TOFST} \right] * G_{CS\_MIN} / I_{OCSET}$$

$$= \left( \frac{135}{6} * 0.61 * 10^{-3} * 1.3 + 0.55 * 10^{-3} \right) * 30.2 / (41 * 10^{-6}) = 13.3k\Omega$$

### No Load Output Voltage Setting Resistor *RFB* and Adaptive Voltage Positioning Resistor *RDRP*

From Figure 14, the bias current of FB pin is 41uA with ROSC=30.1kΩ.

$$R_{FB} = \frac{R_{L\_MAX} * V_{O\_NLOFST} - V_{CS\_TOFST} * n * R_O}{I_{FB} * R_{L\_MAX}} = \frac{0.61 * 10^{-3} * 20 * 10^{-3} - 0.55 * 10^{-3} * 6 * 0.91 * 10^{-3}}{41 * 10^{-6} * 0.61 * 10^{-3}} = 365\Omega$$

$$R_{DRP} = \frac{R_{FB} * R_{L\_MAX} * G_{CS\_MIN}}{n * R_O} = \frac{365 * 0.61 * 10^{-3} * 30.2}{6 * 0.91 * 10^{-3}} = 1.21k\Omega$$

### Body Braking Related Resistors *RBBFB* and *RBBDRP*

N/A. The body braking during Dynamic VID is disabled.

## IR3087 EXTERNAL COMPONENTS

### PWM Ramp Resistor $R_{PWMRMP}$ and Capacitor $C_{PWMRMP}$

Set PWM ramp magnitude  $V_{PWMRMP}=0.8V$ . Choose 220pF for PWM ramp capacitor  $C_{PWMRMP}$ , and calculate the resistor  $R_{PWMRMP}$ ,

$$R_{PWMRMP} = \frac{V_O}{V_{IN} * f_{SW} * C_{PWMRMP} * [\ln(V_{IN} - V_{DAC}) - \ln(V_{IN} - V_{DAC} - V_{PWMRMP})]}$$

$$= \frac{1.33}{12 * 400 * 10^3 * 220 * 10^{-12} * [\ln(12 - 1.35) - \ln(12 - 1.35 - 0.8)]} = 16.1k\Omega, \text{ choose } R_{PWMRMP}=16.2k\Omega$$

### Inductor Current Sensing Capacitor $C_{CS+}$ and Resistors $R_{CS+}$ and $R_{CS-}$

Choose  $C_{CS+}=47nF$ , and calculate  $R_{CS+}$ ,

$$R_{CS+} = \frac{L/R_L}{C_{CS+}} = \frac{220 * 10^{-9} / (0.47 * 10^{-3})}{47 * 10^{-9}} = 10.0k\Omega$$

The bias currents of CSIN+ and CSIN- are 0.25uA and 0.4uA respectively. Calculate resistor  $R_{CS-}$ ,

$$R_{CS-} = \frac{0.25}{0.4} * R_{CS+} = \frac{0.25}{0.4} * 10.0 * 10^3 = 6.2k\Omega, \text{ choose } R_{CS-}=6.19k\Omega$$

### Over Temperature Setting Resistors $R_{HOTSET1}$ and $R_{HOTSET2}$

Use central over-temperature setting and set the temperature threshold at 115 °C, which corresponds to the IC die temperature of 116 °C. Calculate the HOTSET threshold voltage corresponding to the temperature thresholds.

$$V_{HOTSET} = 4.73 * 10^{-3} * T_J + 1.241 = 4.73 * 10^{-3} * 116 + 1.241 = 1.79V$$

Pre-select  $R_{HOTSET1}=10.0k\Omega$ ,

$$R_{HOTSET2} = \frac{R_{HOTSET1} * V_{HOTSET}}{V_{BIAS} - V_{HOTSET}} = \frac{10 * 10^3 * 1.79}{6.8 - 1.79} = 3.57k\Omega$$

### Phase Delay Timing Resistors $R_{PHASE1}$ and $R_{PHASE2}$

Use central over-temperature setting and set the temperature threshold at 115 °C, which corresponds to the IC die temperature of 116 °C. Calculate the HOTSET threshold voltage corresponding to the temperature thresholds.

The phase delay resistor ratios for phases 1 to 6 at 400kHz of switching frequencies are  $R_{PHASE1}=0.628$ ,  $R_{PHASE2}=0.415$ ,  $R_{PHASE3}=0.202$ ,  $R_{PHASE4}=0.246$ ,  $R_{PHASE5}=0.441$  and  $R_{PHASE6}=0.637$  starting from down-slope. Pre-select  $R_{PHASE11}=R_{PHASE21}=R_{PHASE31}=R_{PHASE41}=R_{PHASE51}=R_{PHASE61}=10k\Omega$ ,

$$R_{PHASE12} = \frac{R_{PHASE1}}{1 - R_{PHASE1}} * R_{PHASE11} = \frac{0.628}{1 - 0.628} * 10 * 10^3 = 16.9k\Omega$$

$R_{PHASE22}=7.15k\Omega$ ,  $R_{PHASE32}=2.55k\Omega$ ,  $R_{PHASE42}=3.24k\Omega$ ,  $R_{PHASE52}=7.87k\Omega$ ,  $R_{PHASE62}=17.4k\Omega$

### Bootstrap Capacitor $C_{BST}$

Choose  $C_{BST}=0.1\mu F$

### Decoupling Capacitors for Phase IC and Power Stage

Choose  $C_{VCC}=0.1\mu F$ ,  $C_{VCCL}=0.1\mu F$

### Opti-Phase Resistors $R_{OP1}$ and $R_{OP2}$

Disable Opti-phase function for phase 1 to keep it running at any load condition. Set the Opti-Phase shedding current threshold for phases 2 to 5 at 20 A. Pre-select  $R_{OP21} = 10.0 \text{ k}\Omega$ , and calculate  $R_{OP22}$ .

$$R_{OP22} = \frac{R_{OP21} * [(I_{O\_OP} / n) * R_L + V_{CS\_TOFST}] * G_{CS}}{V_{BIAS} - [(I_{O\_OP} / n) * R_L + V_{CS\_TOFST}] * G_{CS}} = \frac{20 * 10^3 * [(20 / 6) * 0.47 * 10^{-3} + 0.55 * 10^{-3}] * 34}{6.8 - [(20 / 6) * 0.47 * 10^{-3} + 0.55 * 10^{-3}] * 34} = 438 \Omega$$

Choose  $R_{OP22} = 442 \Omega$

$R_{OP31} = R_{OP41} = R_{OP51} = R_{OP61} = 10.0 \text{ k}\Omega$

$R_{OP32} = R_{OP42} = R_{OP52} = R_{OP62} = 442 \Omega$

### VOLTAGE LOOP COMPENSATION

Type II compensation is used for the converter with AL-Polymer output capacitors. Choose the crossover frequency  $f_c = 40 \text{ kHz}$ , which is 1/10 of the switching frequency per phase, and determine  $R_{CP}$  and  $C_{CP}$ .

$$R_{CP} = \frac{(2\pi * f_c)^2 * L_E * C_E * R_{FB} * V_{RAMP}}{V_O * \sqrt{1 + (2\pi * f_c * C * R_C)^2}} = \frac{(2\pi * 40 * 10^3)^2 * (220 * 10^{-9} / 6) * (560 * 10^{-6} * 10) * 365 * 0.8}{(1.35 - 20 * 10^{-3}) * \sqrt{1 + (2\pi * 40 * 10^3 * 560 * 10^{-6} * 7 * 10^{-3})^2}} = 2.0 \text{ k}\Omega$$

$$C_{CP} = \frac{10 * \sqrt{L_E * C_E}}{R_{CP}} = \frac{10 * \sqrt{(220 * 10^{-9} / 6) * (560 * 10^{-6} * 10)}}{2.0 * 10^3} = 71 \text{ nF}, \text{ Choose } C_{CP} = 68 \text{ nF}$$

Choose  $C_{CP1} = 47 \text{ pF}$  to reduce high frequency noise.

### CURRENT SHARE LOOP COMPENSATION

The crossover frequency of the current share loop  $f_{CI}$  should be at least one decade lower than that of the voltage loop  $f_c$ . Choose the crossover frequency of current share loop  $f_{CI} = 4 \text{ kHz}$ , and calculate  $C_{SCOMP}$ ,

$$F_{MI} = \frac{R_{PWRMP} * C_{PWRMP} * f_{SW} * V_{PWRMP}}{(V_I - V_{PWRMP} - V_{DAC}) * (V_I - V_{DAC})} = \frac{16.2 * 10^3 * 220 * 10^{-12} * 400 * 10^3 * 0.8}{(12 - 0.8 - 1.35) * (12 - 1.35)} = 0.011$$

$$C_{SCOMP} = \frac{0.65 * R_{PWRMP} * V_I * I_O * G_{CS\_ROOM} * R_{LE} * [1 + 2\pi * f_{CI} * C_E * (V_O / I_O)] * F_{MI}}{V_O * 2\pi * f_{CI} * 1.05 * 10^6}$$

$$= \frac{0.65 * 16.2 * 10^3 * 12 * 105 * 34 * (0.47 * 10^{-3} / 6) * [1 + 2\pi * 4 * 10^3 * 560 * 10^{-6} * 10 * (1.33 - 105 * 9.1 * 10^{-4}) / 105] * 0.011}{(1.33 - 105 * 9.1 * 10^{-4}) * 2\pi * 4 * 10^3 * 1.05 * 10^6}$$

$$= 31.4 \text{ nF}$$

Choose  $C_{SCOMP} = 33 \text{ nF}$ .

## DESIGN EXAMPLE 2 - EVRD 10 HIGH FREQUENCY ALL-CERAMIC CONVERTER

### SPECIFICATIONS

Input Voltage:  $V_I=12\text{ V}$   
 DAC Voltage:  $V_{DAC}=1.3\text{ V}$   
 No Load Output Voltage Offset:  $V_{O\_NLOFST}=20\text{ mV}$   
 Output Current:  $I_O=105\text{ ADC}$   
 Maximum Output Current:  $I_{OMAX}=120\text{ ADC}$   
 Output Impedance:  $R_O=0.91\text{ m}\Omega$   
 VCC Ready to VCC Power Good Delay:  $t_{VCCPG}=0\text{-}10\text{mS}$   
 Soft Start Time:  $t_{SS}=3\text{mS}$   
 Over Current Delay:  $t_{OCDEL}<0.5\text{mS}$   
 Dynamic VID Down-Slope Slew Rate:  $SR_{DOWN}=2.5\text{mV/uS}$   
 Over Temperature Threshold:  $T_{PCB}=115\text{ }^\circ\text{C}$

### POWER STAGE

Phase Number:  $n=6$   
 Switching Frequency:  $f_{sw}=800\text{ kHz}$   
 Output Inductors:  $L=100\text{ nH}$ ,  $R_L=0.5\text{ m}\Omega$   
 Output Capacitors: Ceramic,  $C=22\mu\text{F}$ ,  $R_C=2\text{m}\Omega$ , Number  $C_n=62$

### IR3081A EXTERNAL COMPONENTS

#### Oscillator Resistor $R_{osc}$

Once the switching frequency is chosen,  $R_{osc}$  can be determined from the curve in Figure 13 data sheet. For switching frequency of 800kHz per phase, choose  $R_{osc}=13.3\text{k}\Omega$

#### Soft Start Capacitor $C_{SS/DEL}$

Determine the soft start capacitor from the required soft start time.

$$C_{SS/DEL} = \frac{I_{CHG} * t_{SS}}{V_O} = \frac{70 * 10^{-6} * 3 * 10^{-3}}{1.3 - 20 * 10^{-3}} = 0.16\mu\text{F}, \text{ choose } C_{SS/DEL}=0.15\mu\text{F}$$

The soft start delay time is

$$t_{SSDEL} = \frac{C_{SS/DEL} * 1.3}{I_{CHG}} = \frac{0.15 * 10^{-6} * 1.3}{70 * 10^{-6}} = 2.8\text{mS}$$

The power good delay time is

$$t_{VCCPG} = \frac{C_{SS/DEL} * (3.735 - V_O - 1.3)}{I_{CHG}} = \frac{0.15 * 10^{-6} * (3.735 - 1.33 - 1.3)}{70 * 10^{-6}} = 2.4\text{ms}$$

Over current delay time is

$$t_{OCDEL} = \frac{C_{SS/DEL} * 0.115}{I_{OCDISCHG}} = \frac{0.15 * 10^{-6} * 0.115}{40 * 10^{-6}} = 0.43\text{ms}$$

#### VDAC Slew Rate Programming Capacitor $C_{VDAC}$ and Resistor $R_{VDAC}$

From Figure 15, the sink current of VDAC pin corresponding to 800kHz ( $R_{osc}=13.3\text{k}\Omega$ ) is 170uA. Calculate the VDAC down-slope slew-rate programming capacitor from the required down-slope slew rate.

$$C_{VDAC} = \frac{I_{SINK}}{SR_{DOWN}} = \frac{170 * 10^{-6}}{2.5 * 10^{-3} / 10^{-6}} = 68nF$$

Calculate the programming resistor.

$$R_{VDAC} = 0.5 + \frac{3.2 * 10^{-15}}{C_{VDAC}^2} = 0.5 + \frac{3.2 * 10^{-15}}{(68 * 10^{-9})^2} = 1.2\Omega$$

From Figure 15, the source current of VDAC pin is 250uA. The VDAC up-slope slew rate is

$$SR_{UP} = \frac{I_{SOURCE}}{C_{VDAC}} = \frac{250 * 10^{-6}}{68 * 10^{-9}} = 3.7mV / \mu S$$

### Over Current Setting Resistor $R_{OCSET}$

The room temperature is 25°C and the target PCB temperature is 100 °C. The phase IC die temperature is about 1 °C higher than that of phase IC, and the inductor temperature is close to PCB temperature.

Calculate Inductor DC resistance at 100 °C,

$$R_{L\_MAX} = R_{L\_ROOM} * [1 + 3850 * 10^{-6} * (T_{L\_MAX} - T_{ROOM})] = 0.5 * 10^{-3} * [1 + 3850 * 10^{-6} * (100 - 25)] = 0.64m\Omega$$

The current sense amplifier gain is 34 at 25°C, and its gain at 101°C is calculated as,

$$G_{CS\_MIN} = G_{CS\_ROOM} * [1 - 1470 * 10^{-6} * (T_{IC\_MAX} - T_{ROOM})] = 34 * [1 - 1470 * 10^{-6} * (101 - 25)] = 30.2$$

Set the over current limit at 135A. From Figure 14, the bias current of OCSET pin (IOCSET) is 90uA with  $R_{OSC}=13.3k\Omega$ . The total current sense amplifier input offset voltage is 0.55mV, which includes the offset created by the current sense amplifier input resistor mismatch.

Calculate constant  $K_P$ , the ratio of inductor peak current over average current in each phase,

$$K_P = \frac{(V_I - V_O) * V_O / (L * V_I * f_{SW} * 2)}{I_{LIMIT} / n} = \frac{(12 - 1.28) * 1.28 / (100 * 10^{-9} * 12 * 800 * 10^3 * 2)}{135 / 6} = 0.32$$

$$R_{OCSET} = \left[ \frac{R_{LIMIT}}{n} * R_{L\_MAX} * (1 + K_P) + V_{CS\_TOFST} \right] * G_{CS\_MIN} / I_{OCSET}$$

$$= \left( \frac{135}{6} * 0.64 * 10^{-3} * 1.32 + 0.55 * 10^{-3} \right) * 30.2 / (90 * 10^{-6}) = 6.34k\Omega$$

### No Load Output Voltage Setting Resistor $R_{FB}$ and Adaptive Voltage Positioning Resistor $R_{DRP}$

From Figure 14, the bias current of FB pin is 90uA with  $R_{OSC}=13.3k\Omega$ .

$$R_{FB} = \frac{R_{L\_MAX} * V_{O\_NLOFST} - V_{CS\_TOFST} * n * R_O}{I_{FB} * R_{L\_MAX}} = \frac{0.64 * 10^{-3} * 20 * 10^{-3} - 0.55 * 10^{-3} * 6 * 0.91 * 10^{-3}}{90 * 10^{-6} * 0.64 * 10^{-3}} = 162\Omega$$

$$R_{DRP} = \frac{R_{FB} * R_{L\_MAX} * G_{CS\_MIN}}{n * R_O} = \frac{162 * 0.64 * 10^{-3} * 30.2}{6 * 0.91 * 10^{-3}} = 576\Omega$$

### Body Braking Related Resistors $R_{BFB}$ and $R_{BDRP}$

N/A. The body braking during Dynamic VID is disabled.

## IR3087 EXTERNAL COMPONENTS

### PWM Ramp Resistor $R_{PWMRMP}$ and Capacitor $C_{PWMRMP}$

Set PWM ramp magnitude  $V_{PWMRMP}=0.75V$ . Choose 100pF for PWM ramp capacitor  $C_{PWMRMP}$ , and calculate the resistor  $R_{PWMRMP}$ ,

$$R_{PWMRMP} = \frac{V_O}{V_{IN} * f_{SW} * C_{PWMRMP} * [\ln(V_{IN} - V_{DAC}) - \ln(V_{IN} - V_{DAC} - V_{PWMRMP})]}$$

$$= \frac{1.28}{12 * 800 * 10^3 * 100 * 10^{-12} * [\ln(12 - 1.3) - \ln(12 - 1.3 - 0.75)]} = 18.2k\Omega$$

### Inductor Current Sensing Capacitor $C_{CS+}$ and Resistors $R_{CS+}$ and $R_{CS-}$

Choose 47nF for capacitor  $C_{CS+}$ , and calculate  $R_{CS+}$ ,

$$R_{CS+} = \frac{L/R_L}{C_{CS+}} = \frac{100 * 10^{-9} / (0.5 * 10^{-3})}{47 * 10^{-9}} = 4.22k\Omega$$

The bias currents of CSIN+ and CSIN- are 0.25uA and 0.4uA respectively. Calculate resistor  $R_{CS-}$ ,

$$R_{CS-} = \frac{0.25}{0.4} * R_{CS+} = \frac{0.25}{0.4} * 4.22 * 10^3 = 2.61k\Omega$$

### Combined Over Temperature and Phase Delay Setting Resistors $R_{PHASEx1}$ , $R_{PHASEx2}$ and $R_{PHASEx3}$

The over temperature setting resistor divider is combined with the phase delay resistor divider. Set the temperature threshold at 115 °C, which corresponds to the IC die temperature of 116 °C, and calculate the HOTSET threshold voltage corresponding to the temperature thresholds.

$$V_{HOTSET} = 4.73 * 10^{-3} * T_J + 1.241 = 4.73 * 10^{-3} * 116 + 1.241 = 1.79V$$

The phase delay resistor ratios for phases 1 to 6 at 800kHz of switching frequencies are  $R_{PHASE1}=0.665$ ,  $R_{PHASE2}=0.432$ ,  $R_{PHASE3}=0.198$ ,  $R_{PHASE4}=0.206$ ,  $R_{PHASE5}=0.401$  and  $R_{PHASE6}=0.597$  starting from down-slope.

The over temperature setting voltage of phases 1, 2, 5, and 6 is lower than the phase delay setting voltage,  $V_{BIAS} * R_{PHASEx}$ . Pre-select  $R_{PHASE11}=10k\Omega$ ,

$$R_{PHASEx2} = \frac{(R_{PHASEx1} * V_{BIAS} - V_{HOTSET}) * R_{PHASEx1}}{V_{BIAS} * (1 - R_{PHASEx})} = \frac{(0.665 * 6.8 - 1.79) * 10 * 10^3}{6.8 * (1 - 0.665)} = 12.1k\Omega$$

$$R_{PHASEx3} = \frac{V_{HOTSET} * R_{PHASEx1}}{V_{BIAS} * (1 - R_{PHASEx})} = \frac{1.79 * 12.1 * 10^3}{6.8 * (1 - 0.665)} = 7.87k\Omega$$

$R_{PHASE21}=10k\Omega$ ,  $R_{PHASE22}=2.94k\Omega$ ,  $R_{PHASE23}=4.64k\Omega$

$R_{PHASE51}=10k\Omega$ ,  $R_{PHASE52}=2.32k\Omega$ ,  $R_{PHASE53}=4.42k\Omega$

$R_{PHASE61}=10k\Omega$ ,  $R_{PHASE62}=8.25k\Omega$ ,  $R_{PHASE63}=6.49k\Omega$

The over temperature setting voltage of Phases 3 and 4 is higher than the phase delay setting voltage,  $V_{BIAS} * R_{PHASEx}$ . Pre-select  $R_{PHASE31}=10k\Omega$ ,

$$R_{PHASE32} = \frac{(V_{HOTSET} - R_{PHASE31} * V_{BIAS}) * R_{PHASE31}}{V_{BIAS} - V_{HOTSET}} = \frac{(1.79 - 0.198 * 6.8) * 10 * 10^3}{6.8 - 1.79} = 887\Omega$$

$$R_{PHASE33} = \frac{R_{PHASE31} * V_{BIAS} * R_{PHASE31}}{V_{BIAS} - V_{HOTSET}} = \frac{0.198 * 6.8 * 10 * 10^3}{6.8 - 1.79} = 2.67k\Omega$$

RPHASE41=10kΩ, RPHASE42=768Ω, RPHASE43=2.80kΩ

### Bootstrap Capacitor CBST

Choose CBST=0.1uF

### Decoupling Capacitors for Phase IC and Power Stage

Choose CVCC=0.1uF, CVCCL=0.1uF

### Opti-Phase Resistors ROP1 and ROP2

Disable Opti-phase function for phase 1 to keep it running at any load condition. Set the Opti-Phase shedding current threshold for phases 2 to 5 at 20 A. Pre-select ROP21 = 10.0 kΩ, and calculate ROP22.

$$R_{OP22} = \frac{R_{OP21} * [(I_{O\_OP} / n) * R_L + V_{CS\_TOFST}] * G_{CS}}{V_{BIAS} - [(I_{O\_OP} / n) * R_L + V_{CS\_TOFST}] * G_{CS}} = \frac{20 * 10^3 * [(20 / 6) * 0.5 * 10^{-3} + 0.55 * 10^{-3}] * 34}{6.8 - [(20 / 6) * 0.5 * 10^{-3} + 0.55 * 10^{-3}] * 34} = 464\Omega$$

ROP31 = ROP41 = ROP51 = ROP61 = 10.0 kΩ

ROP32 = ROP42 = ROP52 = ROP62 = 464 Ω

### VOLTAGE LOOP COMPENSATION

Type III compensation is used for the converter with only ceramic output capacitors. The crossover frequency and phase margin of the voltage loop can be estimated as follows.

$$f_{C1} = \frac{R_{DRP}}{2\pi * C_E * G_{CS} * R_{FB} * R_{LE}} = \frac{576}{2\pi * (62 * 22 * 10^{-6}) * 34 * 162 * (0.5 * 10^{-3} / 6)} = 146kHz$$

$$\theta_{C1} = 90 - A \tan(0.5) * \frac{180}{\pi} = 63^\circ$$

$$\text{Choose } R_{FB1} = \frac{2}{3} * R_{FB} = \frac{2}{3} * 162 = 110\Omega$$

Choose the desired crossover frequency fc (=140kHz) around fc1 estimated above, and calculate

$$C_{FB} = \frac{1}{4\pi * f_c * R_{FB1}} = \frac{1}{4\pi * 140 * 10^3 * 110} = 5.2nF, \text{ choose } C_{FB}=5.6nF$$

$$C_{DRP} = \frac{(R_{FB} + R_{FB1}) * C_{FB}}{R_{DRP}} = \frac{(162 + 110) * 5.6 * 10^{-9}}{576} = 2.7nF$$

$$R_{CP} = \frac{(2\pi * f_c)^2 * L_E * C_E * R_{FB} * V_{RAMP}}{V_O} = \frac{(2\pi * 140 * 10^3)^2 * (100 * 10^{-9} / 6) * (22 * 10^{-6} * 62) * 162 * 0.75}{1.3 - 20 * 10^{-3}} = 1.65k\Omega$$

$$C_{CP} = \frac{10 * \sqrt{L_E * C_E}}{R_{CP}} = \frac{10 * \sqrt{(100 * 10^{-9} / 6) * (22 * 10^{-6} * 62)}}{1.65 * 10^3} = 27nF$$

Choose CCP1=47pF to reduce high frequency noise.

### CURRENT SHARE LOOP COMPENSATION

The crossover frequency of the current share loop  $f_{CI}$  should be at least one decade lower than that of the voltage loop  $f_c$ . Choose the crossover frequency of current share loop  $f_{CI}=3.5\text{kHz}$ , and calculate  $C_{SCOMP}$ ,

$$F_{MI} = \frac{R_{PWRMP} * C_{PWRMP} * f_{SW} * V_{PWRMP}}{(V_I - V_{PWRMP} - V_{DAC}) * (V_I - V_{DAC})} = \frac{18.2 * 10^3 * 100 * 10^{-12} * 800 * 10^3 * 0.75}{(12 - 0.75 - 1.3) * (12 - 1.3)} = 0.011$$

$$C_{SCOMP} = \frac{0.65 * R_{PWRMP} * V_I * I_O * G_{CS\_ROOM} * R_{LE} * [1 + 2\pi * f_{CI} * C_E * (V_O / I_O)] * F_{MI}}{V_O * 2\pi * f_{CI} * 1.05 * 10^6}$$

$$= \frac{0.65 * 18.2 * 10^3 * 12 * 105 * 34 * (0.5 * 10^{-3} / 6) * [1 + 2\pi * 3500 * 22 * 10^{-6} * 62 * (1.33 - 105 * 9.1 * 10^{-4}) / 105] * 0.011}{(1.33 - 105 * 9.1 * 10^{-4}) * 2\pi * 3500 * 1.05 * 10^6}$$

$$= 20.6\text{nF}$$

**LAYOUT GUIDELINES**

The following layout guidelines are recommended to reduce the parasitic inductance and resistance of the PCB layout, therefore minimizing the noise coupled to the IC.

- Dedicate at least one middle layer for a ground plane, which is then split into signal ground plane (LGND) and power ground plane (PGND).
- Connect PGND to LGND pins of each phase IC to the ground tab, which is tied to LGND and PGND planes respectively through vias.
- In order to reduce the noise coupled to SCOMP pin of phase IC, use a dedicated wire to connect the capacitor CSCOMP directly to LGND pin. However, connect PWM ramp capacitor CPWMRMP, phase delay programming resistor RPHASE2 or RPHASE3, decoupling capacitor CVCC to LGND plane through vias.
- Place current sense resistors and capacitors (RCS+, RCS-, CCS+, and CCS-) close to phase IC. Use Kelvin connection for the inductor current sense wires, but separate the two wires by ground polygon. The wire from the inductor terminal to RCS- should not cross over the fast transition nodes, i.e. switching nodes, gate drive outputs and bootstrap nodes.
- Place the decoupling capacitors CVCC and CVCCL as close as possible to VCC and VCCL pins of the phase IC respectively.
- Place the phase IC as close as possible to the MOSFETs to reduce the parasitic resistance and inductance of the gate drive paths.
- Place the input ceramic capacitors close to the drain of top MOSFET and the source of bottom MOSFET. Use combination of different packages of ceramic capacitors.
- There are two switching power loops. One loop includes the input capacitors, top MOSFET, inductor, output capacitors and the load; another loop consists of bottom MOSFET, inductor, output capacitors and the load. Route the switching power paths using wide and short traces or polygons; use multiple vias for connections between layers.

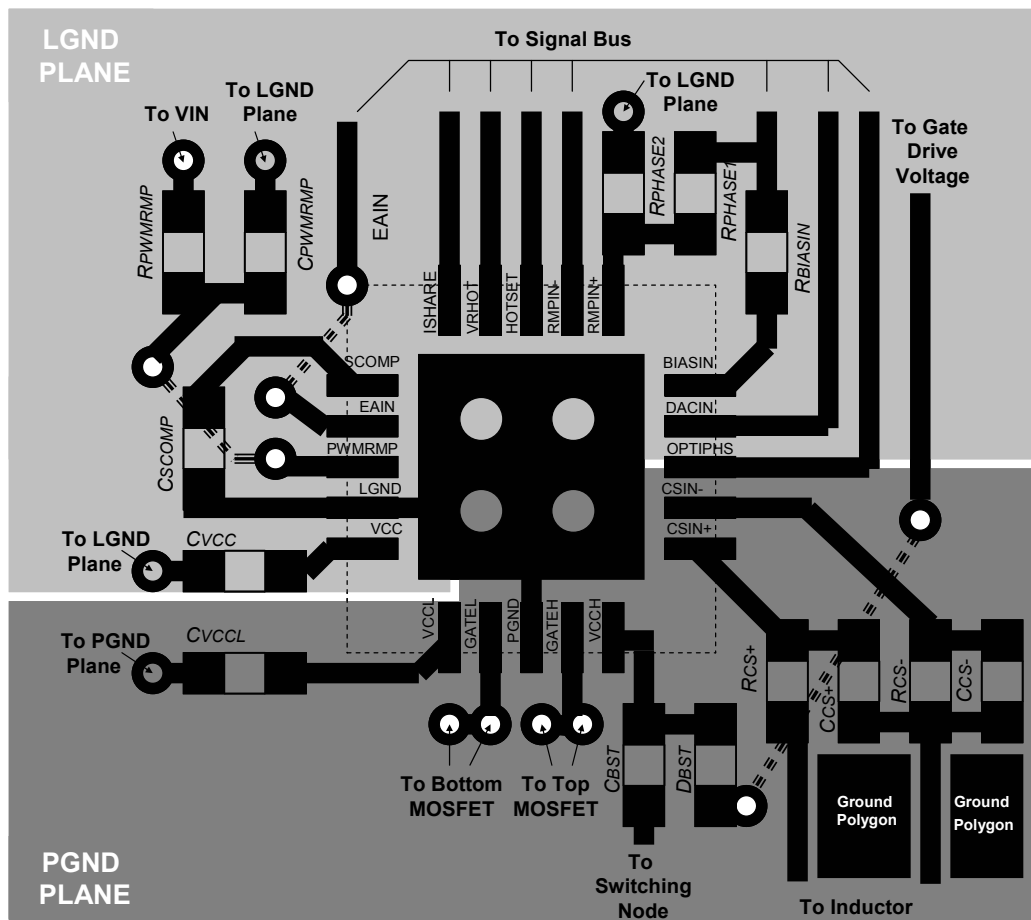

**PCB Metal and Component Placement**

- Lead land width should be equal to nominal part lead width. The minimum lead to lead spacing should be  $\geq 0.2\text{mm}$  to minimize shorting.
- Lead land length should be equal to maximum part lead length + 0.2 mm outboard extension + 0.05mm inboard extension. The outboard extension ensures a large and inspectable toe fillet, and the inboard extension will accommodate any part misalignment and ensure a fillet.
- Center pad land length and width should be equal to maximum part pad length and width. However, the minimum metal to metal spacing should be  $\geq 0.17\text{mm}$  for 2 oz. Copper ( $\geq 0.1\text{mm}$  for 1 oz. Copper and  $\geq 0.23\text{mm}$  for 3 oz. Copper)
- Four 0.3mm diameter vias shall be placed in the pad land spaced at 1.2mm, and connected to ground to minimize the noise effect on the IC, and to transfer heat to the PCB.

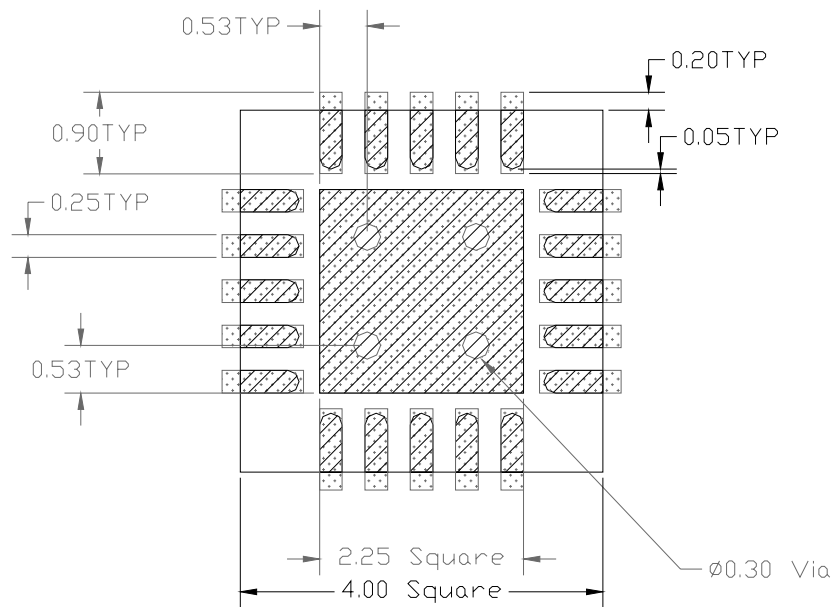

All Dimensions in mm

-  PCB Copper
-  Component

**Solder Resist**

- The solder resist should be pulled away from the metal lead lands by a minimum of 0.06mm. The solder resist mis-alignment is a maximum of 0.05mm and it is recommended that the lead lands are all Non Solder Mask Defined (NSMD). Therefore pulling the S/R 0.06mm will always ensure NSMD pads.
- The minimum solder resist width is 0.13mm, therefore it is recommended that the solder resist is completely removed from between the lead lands forming a single opening for each “group” of lead lands.
- At the inside corner of the solder resist where the lead land groups meet, it is recommended to provide a fillet so a solder resist width of  $\geq 0.17\text{mm}$  remains.
- The land pad should be Solder Mask Defined (SMD), with a minimum overlap of the solder resist onto the copper of 0.06mm to accommodate solder resist mis-alignment. In 0.5mm pitch cases it is allowable to have the solder resist opening for the land pad to be smaller than the part pad.
- Ensure that the solder resist in-between the lead lands and the pad land is  $\geq 0.15\text{mm}$  due to the high aspect ratio of the solder resist strip separating the lead lands from the pad land.
- The 4 vias in the land pad should be tented with solder resist 0.4mm diameter, or 0.1mm larger than the diameter of the via.

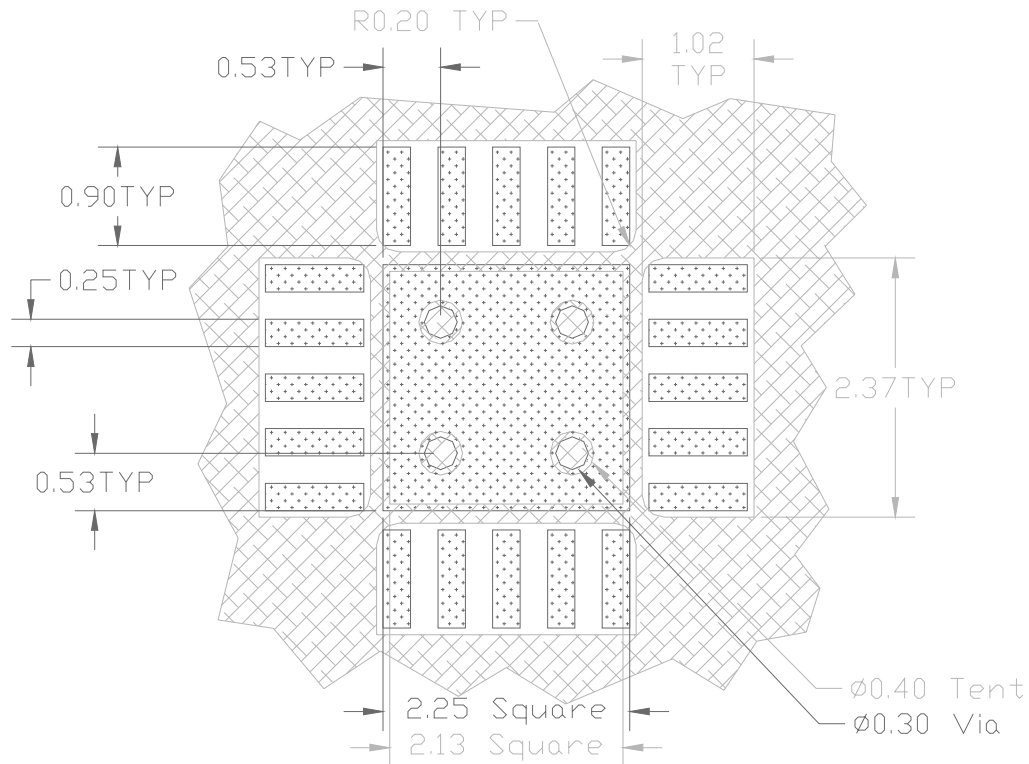

All Dimensions in mm

- PCB Copper
- PCB Solder Resist

**Stencil Design**

- The stencil apertures for the lead lands should be approximately 80% of the area of the lead lands. Reducing the amount of solder deposited will minimize the occurrence of lead shorts. Since for 0.5mm pitch devices the leads are only 0.25mm wide, the stencil apertures should not be made narrower; openings in stencils < 0.25mm wide are difficult to maintain repeatable solder release.
- The stencil lead land apertures should therefore be shortened in length by 80% and centered on the lead land.
- The land pad aperture should be striped with 0.25mm wide openings and spaces to deposit approximately 50% area of solder on the center pad. If too much solder is deposited on the center pad the part will float and the lead lands will be open.
- The maximum length and width of the land pad stencil aperture should be equal to the solder resist opening minus an annular 0.2mm pull back to decrease the incidence of shorting the center land to the lead lands when the part is pushed into the solder paste.

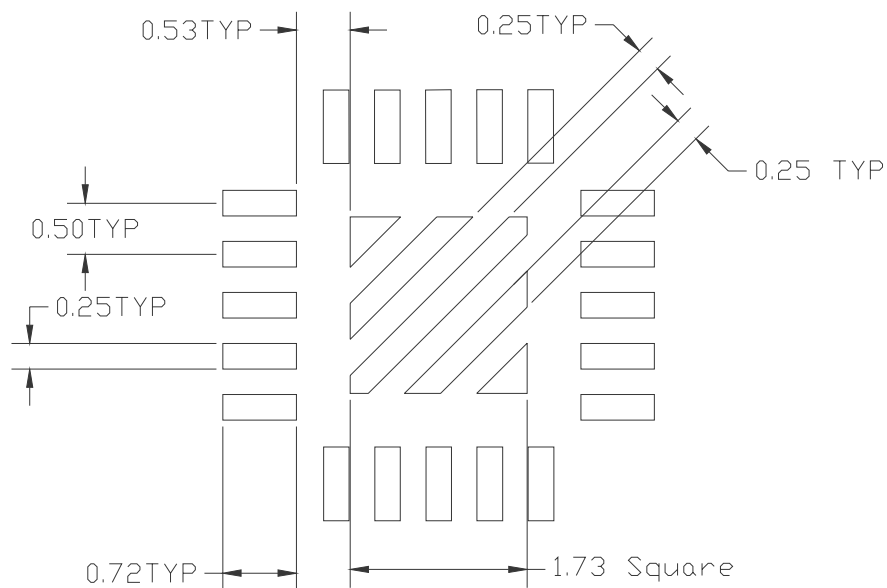

Stencil Aperture  
All Dimensions in mm

**PACKAGE INFORMATION**

**20L MLPQ (4 x 4 mm Body) –  $\theta_{JA} = 32^{\circ}\text{C/W}$ ,  $\theta_{JC} = 3^{\circ}\text{C/W}$**

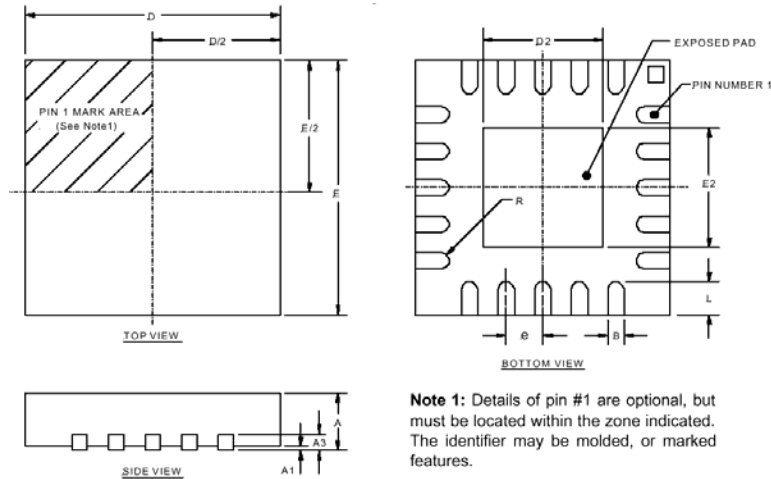

**Note 1:** Details of pin #1 are optional, but must be located within the zone indicated. The identifier may be molded, or marked features.



SYMBOL	20-PIN 4x4		
	MIN	NOM	MAX
A	0.80	0.90	1.00
A1	0.00	0.02	0.05
A3	0.20 REF		
B	0.18	0.23	0.30
D	4.00 BSC		
D2	2.00	2.15	2.25
E	4.00 BSC		
E2	2.00	2.15	2.25
e	0.50 BSC		
L	0.45	0.55	0.65
R	0.09	---	---

NOTE: ALL MEASUREMENTS ARE IN MILLIMETERS.

Data and specifications subject to change without notice. This product has been designed and qualified for the Consumer market. Qualification Standards can be found on IR's Web site.

## Looking for pricing, stock, or lifecycle information?

Click below to explore more details on WIN SOURCE:

-  [View IR3087MPBF on WIN SOURCE](#)
-  [Infineon Technologies](#) Information

## Optimize Your Supply Chain with WIN SOURCE Solutions

-  Global Sourcing Solution
-  Obsolete Management
-  Cost Control Management
-  Shortage Management
-  Alternative Solution
-  Excess Inventory Management