



**THE DATASHEET OF
DS91M040TSQX/NOPB**



DS91M040 125 MHz Quad M-LVDS Transceiver

Check for Samples: [DS91M040](#)

FEATURES

- DC - 125 MHz / 250 Mbps Low Jitter, Low Skew, Low Power Operation
- Wide Input Common Mode Voltage Range Allows up to $\pm 1V$ of GND Noise
- Conforms to TIA/EIA-899 M-LVDS Standard
- Pin Selectable M-LVDS Receiver Type (1 or 2)
- Controlled Transition Times (2.0 ns typ) Minimize Reflections
- 8 kV ESD on M-LVDS I/O pins protects adjoining components
- Flow-Through Pinout Simplifies PCB Layout
- Small 5 mm x 5 mm WQFN-32 Space Saving Package

APPLICATIONS

- Multidrop / Multipoint Clock and Data Distribution
- High-Speed, Low Power, Short-Reach Alternative to TIA/EIA-485/422
- Clock Distribution in AdvancedTCA (ATCA) and MicroTCA (μ TCA, uTCA) Backplanes

System Diagram

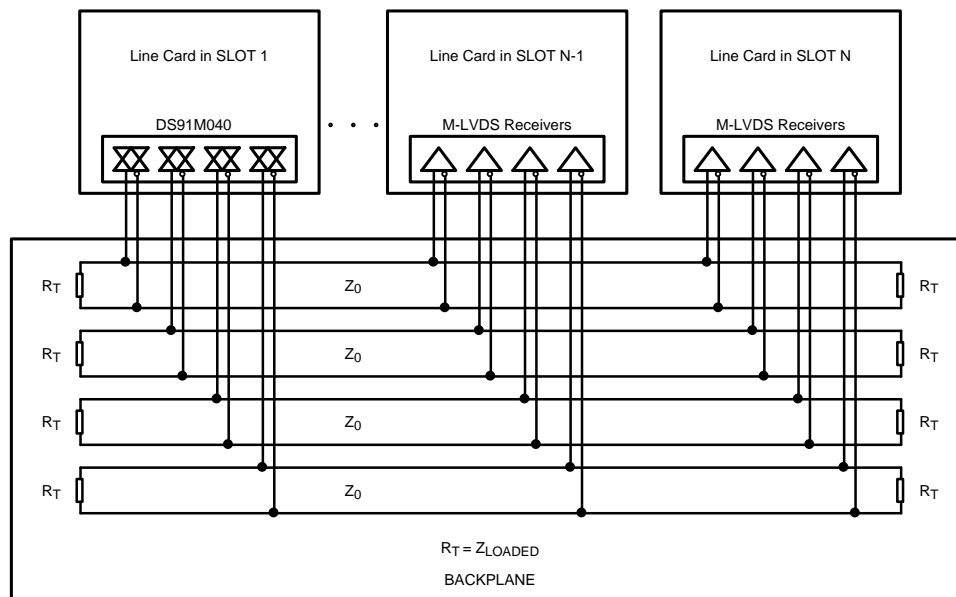

DESCRIPTION

The DS91M040 is a quad M-LVDS transceiver designed for driving / receiving clock or data signals to / from up to four multipoint networks.

M-LVDS (Multipoint LVDS) is a new family of bus interface devices based on LVDS technology specifically designed for multipoint and multidrop cable and backplane applications. It differs from standard LVDS in providing increased drive current to handle double terminations that are required in multipoint applications. Controlled transition times minimize reflections that are common in multipoint configurations due to unterminated stubs. M-LVDS devices also have a very large input common mode voltage range for additional noise margin in heavily loaded and noisy backplane environments.

A single DS91M040 channel is a half-duplex transceiver that accepts LVTTTL/LVCMOS signals at the driver inputs and converts them to differential M-LVDS signal levels. The receiver inputs accept low voltage differential signals (LVDS, BLVDS, M-LVDS, LVPECL and CML) and convert them to 3V LVCMOS signals. The DS91M040 supports both M-LVDS type 1 and type 2 receiver inputs.



Please be aware that an important notice concerning availability, standard warranty, and use in critical applications of Texas Instruments semiconductor products and disclaimers thereto appears at the end of this data sheet.

All trademarks are the property of their respective owners.

Connection Diagram

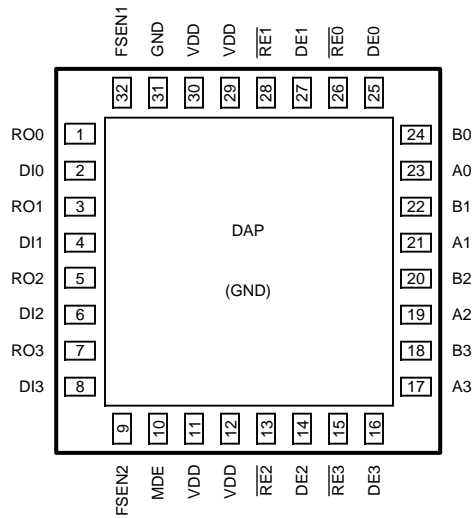

Logic Diagram

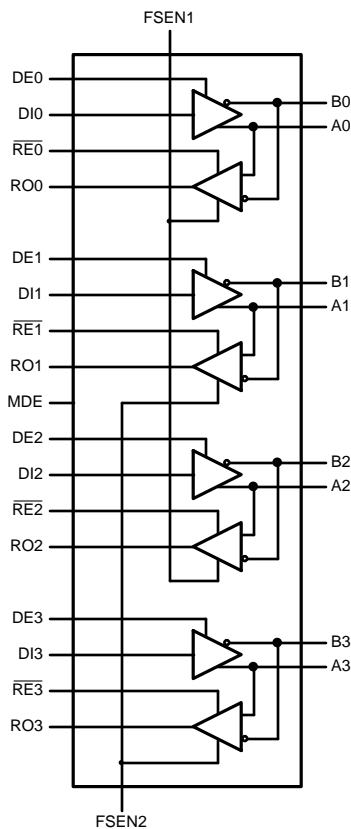

PIN DESCRIPTIONS

Number	Name	I/O, Type	Description
1, 3, 5, 7	RO	O, LVCMOS	Receiver output pin.
26, 28, 13, 15	\overline{RE}	I, LVCMOS	Receiver enable pin: When \overline{RE} is high, the receiver is disabled. When \overline{RE} is low, the receiver is enabled. There is a 300 k Ω pullup resistor on this pin.
25, 27, 14, 16	DE	I, LVCMOS	Driver enable pin: When DE is low, the driver is disabled. When DE is high, the driver is enabled. There is a 300 k Ω pulldown resistor on this pin.
2, 4, 6, 8	DI	I, LVCMOS	Driver input pin.
31, DAP	GND	Power	Ground pin and pad.
17, 19, 21, 23	A	I/O, M-LVDS	Non-inverting driver output pin/Non-inverting receiver input pin
18, 20, 22, 24	B	I/O, M-LVDS	Inverting driver output pin/Inverting receiver input pin
11, 12, 29, 30	V _{DD}	Power	Power supply pin, +3.3V \pm 0.3V
32	FSEN1	I, LVCMOS	Failsafe enable pin with a 300 k Ω pullup resistor. This pin enables Type 2 receiver on inputs 0 and 2. FSEN1 = L --> Type 1 receiver inputs FSEN1 = H --> Type 2 receiver inputs
9	FSEN2	I, LVCMOS	Failsafe enable pin with a 300 k Ω pullup resistor. This pin enables Type 2 receiver on inputs 1 and 3. FSEN2 = L --> Type 1 receiver inputs FSEN2 = H --> Type 2 receiver inputs
10	MDE	I, LVCMOS	Master enable pin. When MDE is H, the device is powered up. When MDE is L, the device overrides all other control and powers down.

M-LVDS Receiver Types

The EIA/TIA-899 M-LVDS standard specifies two different types of receiver input stages. A type 1 receiver has a conventional threshold that is centered at the midpoint of the input amplitude, $V_{ID}/2$. A type 2 receiver has a built in offset that is 100mV greater than $V_{ID}/2$. The type 2 receiver offset acts as a failsafe circuit where open or short circuits at the input will always result in the output stage being driven to a low logic state.

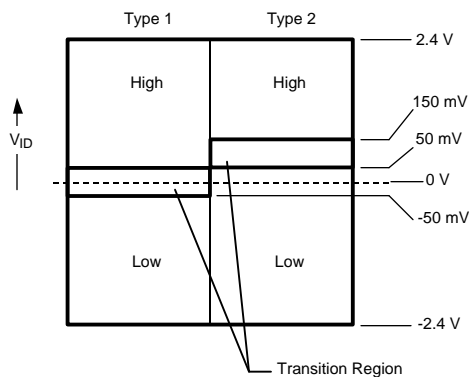

Figure 1. M-LVDS Receiver Input Thresholds



These devices have limited built-in ESD protection. The leads should be shorted together or the device placed in conductive foam during storage or handling to prevent electrostatic damage to the MOS gates.

Absolute Maximum Ratings⁽¹⁾⁽²⁾

Power Supply Voltage		-0.3V to +4V
LVC MOS Input Voltage		-0.3V to ($V_{DD} + 0.3V$)
LVC MOS Output Voltage		-0.3V to ($V_{DD} + 0.3V$)
M-LVDS I/O Voltage		-1.9V to +5.5V
M-LVDS Output Short Circuit Current Duration		Continuous
Junction Temperature		+140°C
Storage Temperature Range		-65°C to +150°C
Lead Temperature Range Soldering (4 sec.)		+260°C
Maximum Package Power Dissipation @ +25°C	RTV Package	3.91W
	Derate RTV Package	34 mW/°C above +25°C
Package Thermal Resistance (4-Layer, 2 oz. Cu, JEDEC)	θ_{JA}	+29.4°C/W
	θ_{JC}	+2.8°C/W
ESD Susceptibility	HBM ⁽³⁾	≥8 kV
	MM ⁽⁴⁾	≥250V
	CDM ⁽⁵⁾	≥1250V

- (1) "Absolute Maximum Ratings" indicate limits beyond which damage to the device may occur, including inoperability and degradation of device reliability and/or performance. Functional operation of the device and/or non-degradation at the Absolute Maximum Ratings or other conditions beyond those indicated in the Recommended Operating Conditions is not implied. The Recommended Operating Conditions indicate conditions at which the device is functional and the device should not be operated beyond such conditions.
- (2) If Military/Aerospace specified devices are required, please contact the TI Sales Office/ Distributors for availability and specifications.
- (3) Human Body Model, applicable std. JESD22-A114C
- (4) Machine Model, applicable std. JESD22-A115-A
- (5) Field Induced Charge Device Model, applicable std. JESD22-C101-C

Recommended Operating Conditions

	Min	Typ	Max	Units
Supply Voltage, V_{DD}	3.0	3.3	3.6	V
Voltage at Any Bus Terminal (Separate or Common-Mode)	-1.4		+3.8	V
Differential Input Voltage V_{ID}			2.4	V
LVTTTL Input Voltage High V_{IH}	2.0		V_{DD}	V
LVTTTL Input Voltage Low V_{IL}	0		0.8	V
Operating Free Air Temperature T_A	-40	+25	+85	°C

DC Electrical Characteristics⁽¹⁾⁽²⁾⁽³⁾⁽⁴⁾

Over recommended operating supply and temperature ranges unless otherwise specified.

Symbol	Parameter	Conditions	Min	Typ	Max	Units	
M-LVDS Driver							
$ V_{AB} $	Differential output voltage magnitude	$R_L = 50\Omega, C_L = 5\text{ pF}$	480		650	mV	
ΔV_{AB}	Change in differential output voltage magnitude between logic states	Figure 2 Figure 4	-50	0	+50	mV	
$V_{OS(SS)}$	Steady-state common-mode output voltage	$R_L = 50\Omega, C_L = 5\text{ pF}$	0.3	1.6	2.1	V	
$ \Delta V_{OS(SS)} $	Change in steady-state common-mode output voltage between logic states	Figure 2 Figure 3	0		+50	mV	
$V_{A(OC)}$	Maximum steady-state open-circuit output voltage	Figure 5	0		2.4	V	
$V_{B(OC)}$	Maximum steady-state open-circuit output voltage		0		2.4	V	
$V_{P(H)}$	Voltage overshoot, low-to-high level output ⁽⁵⁾	$R_L = 50\Omega, C_L = 5\text{ pF}, C_D = 0.5\text{ pF}$			$1.2V_{SS}$	V	
$V_{P(L)}$	Voltage overshoot, high-to-low level output ⁽⁵⁾	Figure 7 Figure 8	-0.2V ss			V	
I_{IH}	High-level input current (LVTTTL inputs)	$V_{IH} = 3.6\text{V}$	-15		15	μA	
I_{IL}	Low-level input current (LVTTTL inputs)	$V_{IL} = 0.0\text{V}$	-15		15	μA	
V_{CL}	Input Clamp Voltage (LVTTTL inputs)	$I_{IN} = -18\text{ mA}$	-1.5			V	
I_{OS}	Differential short-circuit output current ⁽⁶⁾	Figure 6	-43		43	mA	
M-LVDS Receiver							
V_{IT+}	Positive-going differential input voltage threshold	See Truth Tables	Type 1		16	50	mV
			Type 2		100	150	mV
V_{IT-}	Negative-going differential input voltage threshold	See Truth Tables	Type 1	-50	20		mV
			Type 2	50	94		mV
V_{OH}	High-level output voltage (LVTTTL output)	$I_{OH} = -8\text{ mA}$	2.4	2.7		V	
V_{OL}	Low-level output voltage (LVTTTL output)	$I_{OL} = 8\text{ mA}$		0.28	0.4	V	
I_{OZ}	TRI-STATE output current	$V_O = 0\text{V}$ or 3.6V	-10		10	μA	
I_{OSR}	Short-circuit receiver output current (LVTTTL output)	$V_O = 0\text{V}$		-50	-90	mA	

- (1) The Electrical Characteristics tables list ensured specifications under the listed Recommended Operating Conditions except as otherwise modified or specified by the Electrical Characteristics Conditions and/or Notes. Typical specifications are estimations only and are not ensured.
- (2) Current into device pins is defined as positive. Current out of device pins is defined as negative. All voltages are referenced to ground except V_{OD} and ΔV_{OD} .
- (3) Typical values represent most likely parametric norms for $V_{DD} = +3.3\text{V}$ and $T_A = +25^\circ\text{C}$, and at the Recommended Operation Conditions at the time of product characterization and are not specified.
- (4) C_L includes fixture capacitance and C_D includes probe capacitance.
- (5) Specification is ensured by characterization and is not tested in production.
- (6) Output short circuit current (I_{OS}) is specified as magnitude only, minus sign indicates direction only.

DC Electrical Characteristics⁽¹⁾⁽²⁾⁽³⁾⁽⁴⁾ (continued)

Over recommended operating supply and temperature ranges unless otherwise specified.

Symbol	Parameter	Conditions	Min	Typ	Max	Units
M-LVDS Bus (Input and Output) Pins						
I_A	Transceiver input/output current	$V_A = 3.8V, V_B = 1.2V$			32	μA
		$V_A = 0V$ or $2.4V, V_B = 1.2V$	-20		+20	μA
		$V_A = -1.4V, V_B = 1.2V$	-32			μA
I_B	Transceiver input/output current	$V_B = 3.8V, V_A = 1.2V$			32	μA
		$V_B = 0V$ or $2.4V, V_A = 1.2V$	-20		+20	μA
		$V_B = -1.4V, V_A = 1.2V$	-32			μA
I_{AB}	Transceiver input/output differential current ($I_A - I_B$)	$V_A = V_B, -1.4V \leq V \leq 3.8V$	-4		+4	μA
$I_{A(OFF)}$	Transceiver input/output power-off current	$V_A = 3.8V, V_B = 1.2V,$ $DE = 0V$ $0V \leq V_{DD} \leq 1.5V$			32	μA
		$V_A = 0V$ or $2.4V, V_B = 1.2V,$ $DE = 0V$ $0V \leq V_{DD} \leq 1.5V$	-20		+20	μA
		$V_A = -1.4V, V_B = 1.2V,$ $DE = 0V$ $0V \leq V_{DD} \leq 1.5V$	-32			μA
$I_{B(OFF)}$	Transceiver input/output power-off current	$V_B = 3.8V, V_A = 1.2V,$ $DE = 0V$ $0V \leq V_{DD} \leq 1.5V$			32	μA
		$V_B = 0V$ or $2.4V, V_A = 1.2V,$ $DE = 0V$ $0V \leq V_{DD} \leq 1.5V$	-20		+20	μA
		$V_B = -1.4V, V_A = 1.2V,$ $DE = 0V$ $0V \leq V_{DD} \leq 1.5V$	-32			μA
$I_{AB(OFF)}$	Transceiver input/output power-off differential current ($I_{A(OFF)} - I_{B(OFF)}$)	$V_A = V_B, -1.4V \leq V \leq 3.8V,$ $DE = 0V$ $0V \leq V_{DD} \leq 1.5V$	-4		+4	μA
C_A	Transceiver input/output capacitance	$V_{DD} = OPEN$		7.8		pF
C_B	Transceiver input/output capacitance			7.8		pF
C_{AB}	Transceiver input/output differential capacitance			3		pF
$C_{A/B}$	Transceiver input/output capacitance balance (C_A/C_B)			1		
SUPPLY CURRENT (V_{CC})						
I_{CCD}	Driver Supply Current	$R_L = 50\Omega, DE = H, \overline{RE} = H$		67	75	mA
I_{CCZ}	TRI-STATE Supply Current	$DE = L, \overline{RE} = H$		22	26	mA
I_{CCR}	Receiver Supply Current	$DE = L, \overline{RE} = L$		32	38	mA
I_{CCPD}	Power Down Supply Current	$MDE = L$		3	5	mA

Switching Characteristics⁽¹⁾⁽²⁾⁽³⁾

Over recommended operating supply and temperature ranges unless otherwise specified.

Symbol	Parameter	Conditions	Min	Typ	Max	Units
DRIVER AC SPECIFICATIONS						
t_{PLH}	Differential Propagation Delay Low to High	$R_L = 50\Omega$, $C_L = 5\text{ pF}$,	1.5	3.3	5.5	ns
t_{PHL}	Differential Propagation Delay High to Low	$C_D = 0.5\text{ pF}$	1.5	3.3	5.5	ns
t_{SKD1}	Pulse Skew ⁽⁴⁾⁽⁵⁾	Figure 7 Figure 8		30	125	ps
t_{SKD2}	Channel-to-Channel Skew ⁽⁴⁾⁽⁶⁾			100	200	ps
t_{SKD3}	Part-to-Part Skew ⁽⁴⁾⁽⁷⁾			0.8	1.6	ns
t_{SKD4}	Part-to-Part Skew ⁽⁴⁾⁽⁸⁾				4	ns
t_{TLH}	Rise Time ⁽⁴⁾		1.2	2.0	3.0	ns
t_{THL}	Fall Time ⁽⁴⁾		1.2	2.0	3.0	ns
t_{PZH}	Enable Time (Z to Active High)	$R_L = 50\Omega$, $C_L = 5\text{ pF}$,		7.5	11.5	ns
t_{PZL}	Enable Time (Z to Active Low)	$C_D = 0.5\text{ pF}$		8.0	11.5	ns
t_{PLZ}	Disable Time (Active Low to Z)	Figure 9 Figure 10		7.0	11.5	ns
t_{PHZ}	Disable Time (Active High to Z)			7.0	11.5	ns
RECEIVER AC SPECIFICATIONS						
t_{PLH}	Propagation Delay Low to High	$C_L = 15\text{ pF}$	1.5	3.0	4.5	ns
t_{PHL}	Propagation Delay High to Low	Figure 11 Figure 12 Figure 13	1.5	3.1	4.5	ns
t_{SKD1A}	Pulse Skew (Receiver Type 1) ⁽⁴⁾⁽⁵⁾			55	325	ps
t_{SKD1B}	Pulse Skew (Receiver Type 2) ⁽⁴⁾⁽⁵⁾			475	800	ps
t_{SKD2}	Channel-to-Channel Skew ⁽⁴⁾⁽⁶⁾			60	300	ps
t_{SKD3}	Part-to-Part Skew ⁽⁴⁾⁽⁷⁾			0.6	1.2	ns
t_{SKD4}	Part-to-Part Skew ⁽⁸⁾				3	ns
t_{TLH}	Rise Time ⁽⁴⁾		0.3	1.1	1.6	ns
t_{THL}	Fall Time ⁽⁴⁾		0.3	0.65	1.6	ns
t_{PZH}	Enable Time (Z to Active High)	$R_L = 500\Omega$, $C_L = 15\text{ pF}$		3	5.5	ns
t_{PZL}	Enable Time (Z to Active Low)	Figure 14 Figure 15		3	5.5	ns
t_{PLZ}	Disable Time (Active Low to Z)			3.5	5.5	ns
t_{PHZ}	Disable Time (Active High to Z)			3.5	5.5	ns
GENERIC AC SPECIFICATIONS						
t_{WKUP}	Wake Up Time ⁽⁴⁾ (Master Device Enable (MDE) time)				500	ms
f_{MAX}	Maximum Operating Frequency ⁽⁴⁾		125			MHz

- (1) The Electrical Characteristics tables list ensured specifications under the listed Recommended Operating Conditions except as otherwise modified or specified by the Electrical Characteristics Conditions and/or Notes. Typical specifications are estimations only and are not ensured.
- (2) Typical values represent most likely parametric norms for $V_{DD} = +3.3\text{V}$ and $T_A = +25^\circ\text{C}$, and at the Recommended Operation Conditions at the time of product characterization and are not specified.
- (3) C_L includes fixture capacitance and C_D includes probe capacitance.
- (4) Specification is ensured by characterization and is not tested in production.
- (5) t_{SKD1} , $|t_{PLHD} - t_{PHLD}|$, Pulse Skew, is the magnitude difference in differential propagation delay time between the positive going edge and the negative going edge of the same channel.
- (6) t_{SKD2} , Channel-to-Channel Skew, is the difference in propagation delay (t_{PLHD} or t_{PHLD}) among all output channels.
- (7) t_{SKD3} , Part-to-Part Skew, is defined as the difference between the minimum and maximum differential propagation delays. This specification applies to devices at the same V_{DD} and within 5°C of each other within the operating temperature range.
- (8) t_{SKD4} , Part-to-Part Skew, is the differential channel-to-channel skew of any event between devices. This specification applies to devices over recommended operating temperature and voltage ranges, and across process distribution. t_{SKD4} is defined as $|\text{Max} - \text{Min}|$ differential propagation delay.

Test Circuits and Waveforms

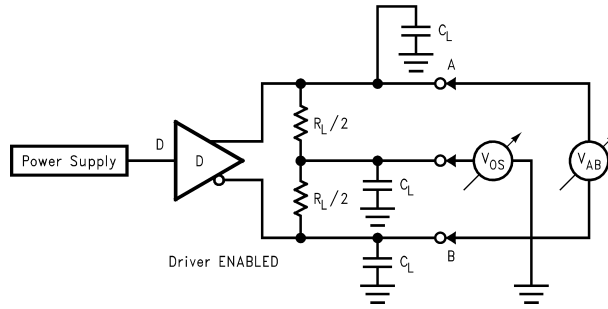

Figure 2. Differential Driver Test Circuit

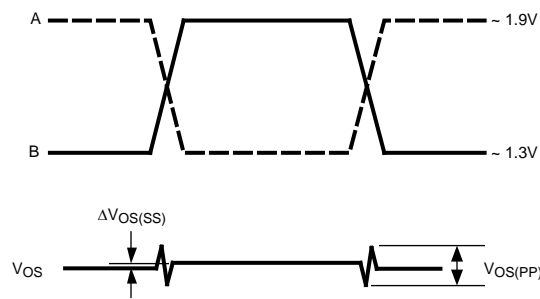

Figure 3. Differential Driver Waveforms

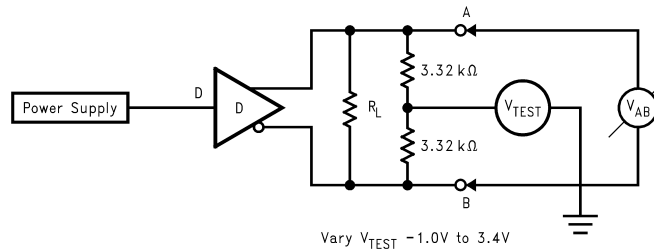

Figure 4. Differential Driver Full Load Test Circuit

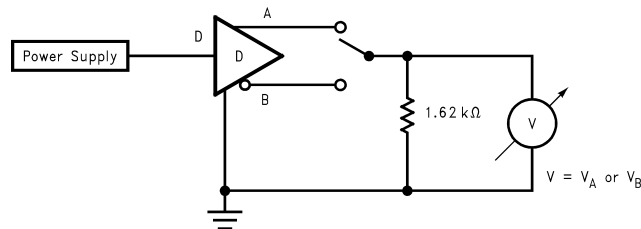

Figure 5. Differential Driver DC Open Test Circuit

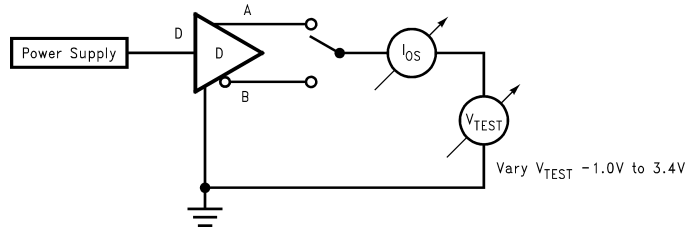

Figure 6. Differential Driver Short-Circuit Test Circuit

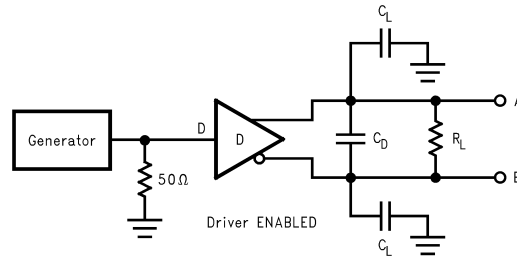

Figure 7. Driver Propagation Delay and Transition Time Test Circuit

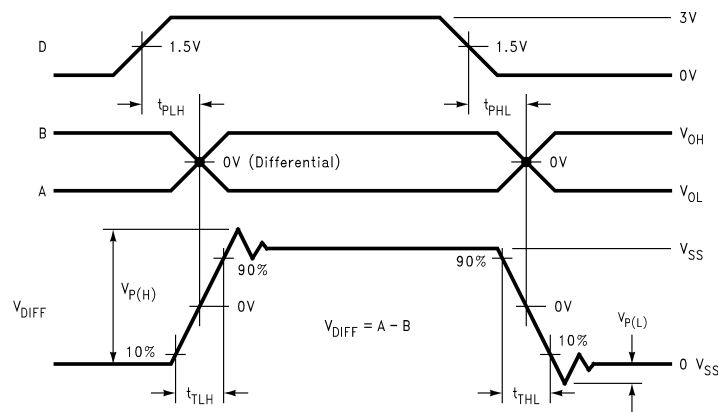

Figure 8. Driver Propagation Delays and Transition Time Waveforms

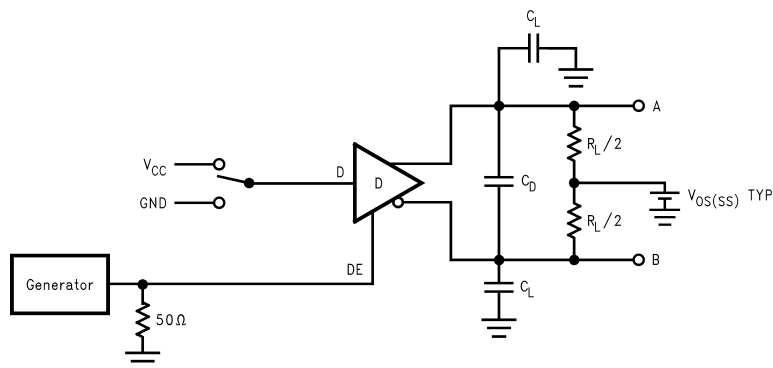

Figure 9. Driver TRI-STATE Delay Test Circuit

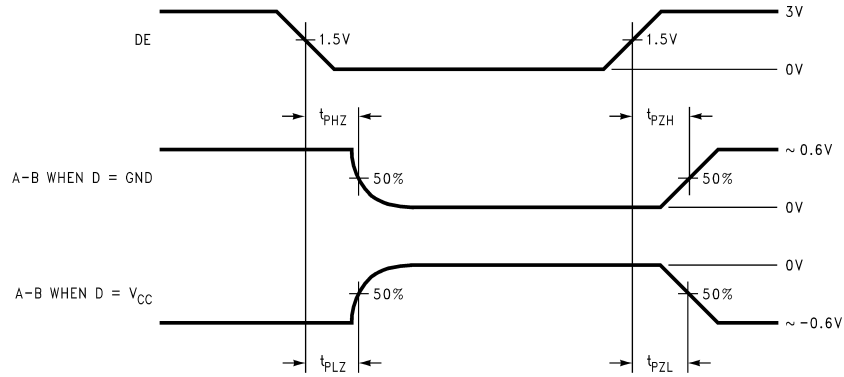

Figure 10. Driver TRI-STATE Delay Waveforms

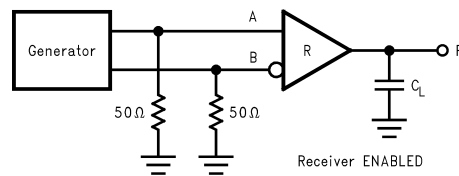

Figure 11. Receiver Propagation Delay and Transition Time Test Circuit

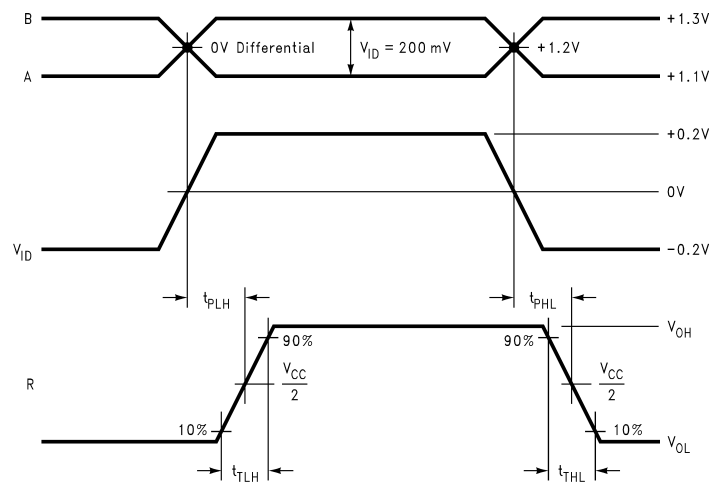

Figure 12. Type 1 Receiver Propagation Delay and Transition Time Waveforms

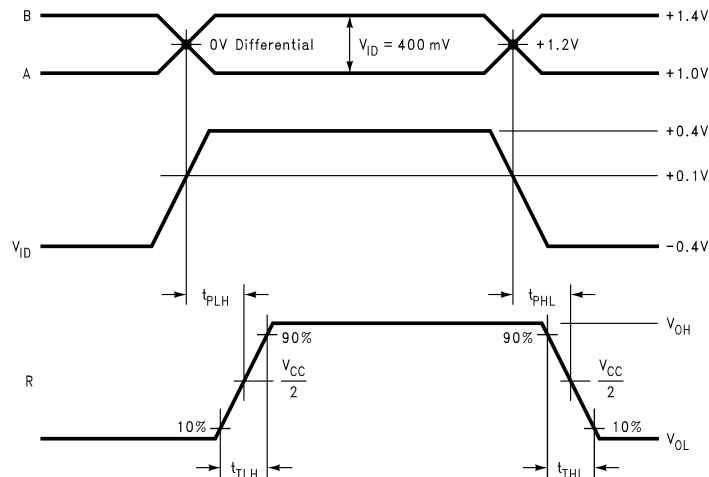

Figure 13. Type 2 Receiver Propagation Delay and Transition Time Waveforms

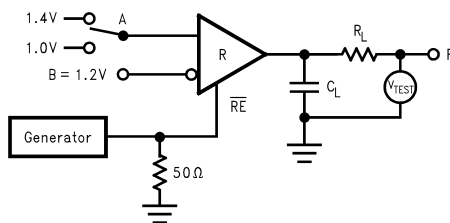

Figure 14. Receiver TRI-STATE Delay Test Circuit

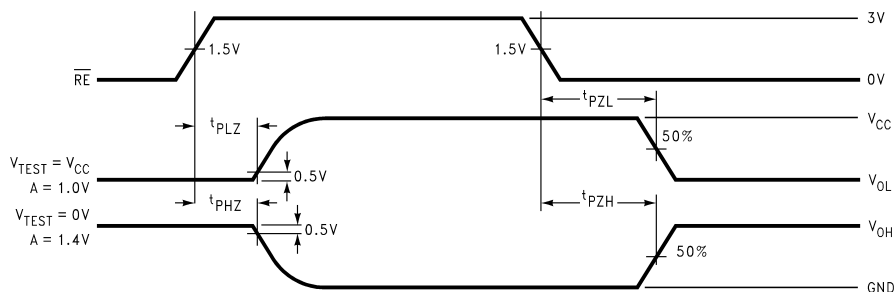

Figure 15. Receiver TRI-STATE Delay Waveforms

TRUTH TABLES

DS91M040 Transmitting⁽¹⁾

Inputs			Outputs	
RE	DE	DI	B	A
X	H	H	L	H
X	H	L	H	L
X	L	X	Z	Z

(1) X — Don't care condition
Z — High impedance state

DS91M040 as Type 1 Receiving⁽¹⁾

Inputs				Output
FSEN	\overline{RE}	DE	A – B	RO
L	L	X	$\geq +0.05V$	H
L	L	X	$\leq -0.05V$	L
L	L	X	$-0.05V \leq A-B \leq +0.05V$	Undefined
L	H	X	X	Z

- (1) X — Don't care condition
Z — High impedance state

DS91M040 as Type 2 Receiving⁽¹⁾

Inputs				Output
FSEN	\overline{RE}	DE	A – B	RO
H	L	X	$\geq +0.15V$	H
H	L	X	$\leq +0.05V$	L
H	L	X	$+0.05V \leq A-B \leq +0.15V$	Undefined
H	H	X	X	Z

- (1) X — Don't care condition
Z — High impedance state

DS91M040 Type 1 Receiver Input Threshold Test Voltages⁽¹⁾

Applied Voltages		Resulting Differential Input Voltage	Resulting Common-Mode Input Voltage	Receiver Output
V_{IA}	V_{IB}	V_{ID}	V_{ICM}	R
2.400V	0.000V	2.400V	1.200V	H
0.000V	2.400V	-2.400V	1.200V	L
3.800V	3.750V	0.050V	3.775V	H
3.750V	3.800V	-0.050V	3.775V	L
-1.350V	-1.400V	0.050V	-1.375V	H
-1.400V	-1.350V	-0.050V	-1.375V	L

- (1) H — High Level
L — Low Level

Output state assumes that the receiver is enabled ($\overline{RE} = L$)

DS91M040 Type 2 Receiver Input Threshold Test Voltages⁽¹⁾

Applied Voltages		Resulting Differential Input Voltage	Resulting Common-Mode Input Voltage	Receiver Output
V_{IA}	V_{IB}	V_{ID}	V_{IC}	R
2.400V	0.000V	2.400V	1.200V	H
0.000V	2.400V	-2.400V	1.200V	L
3.800V	3.650V	0.150V	3.725V	H
3.800V	3.750V	0.050V	3.775V	L
-1.250V	-1.400V	0.150V	-1.325V	H
-1.350V	-1.400V	0.050V	-1.375V	L

- (1) H — High Level
L — Low Level

Output state assumes that the receiver is enabled ($\overline{RE} = L$)

Typical Performance Characteristics

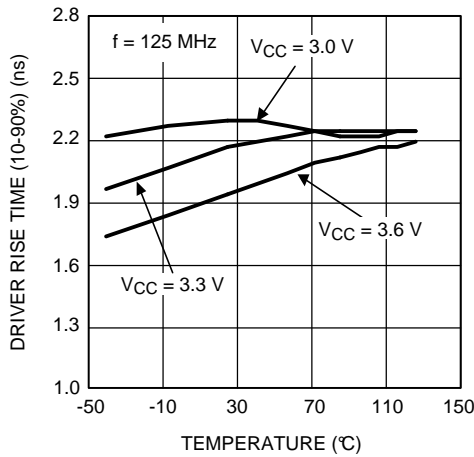

Figure 16. Driver Rise Time as a Function of Temperature

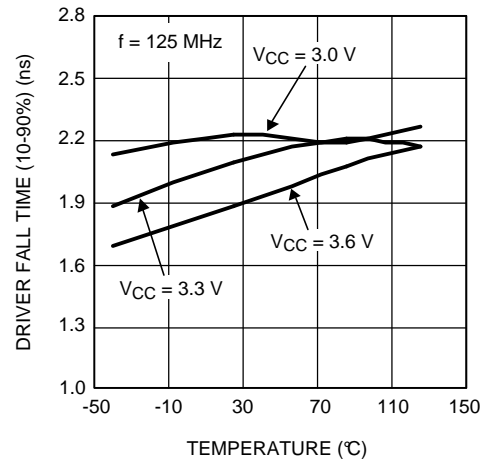

Figure 17. Driver Fall Time as a Function of Temperature

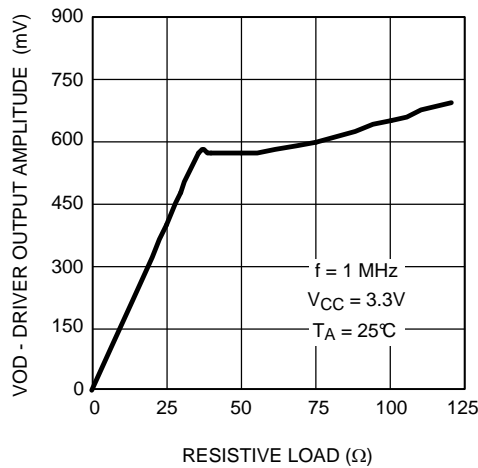

Figure 18. Driver Output Signal Amplitude as a Function of Resistive Load

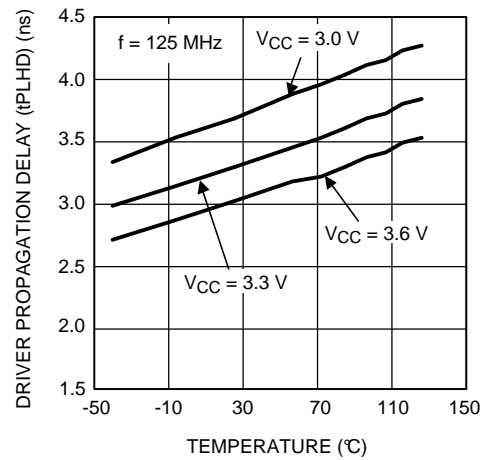

Figure 19. Driver Propagation Delay (tPLHD) as a Function of Temperature

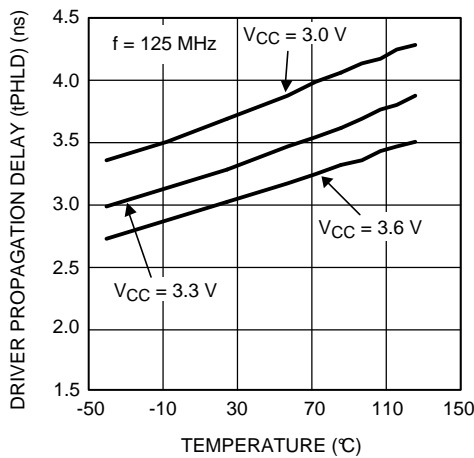

Figure 20. Driver Propagation Delay (tPHLD) as a Function of Temperature

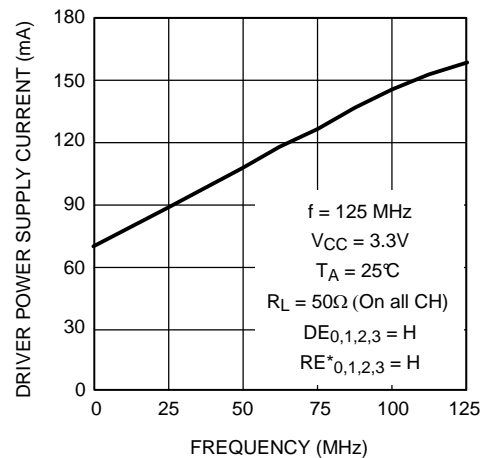

Figure 21. Driver Power Supply Current as a Function of Frequency

Typical Performance Characteristics (continued)

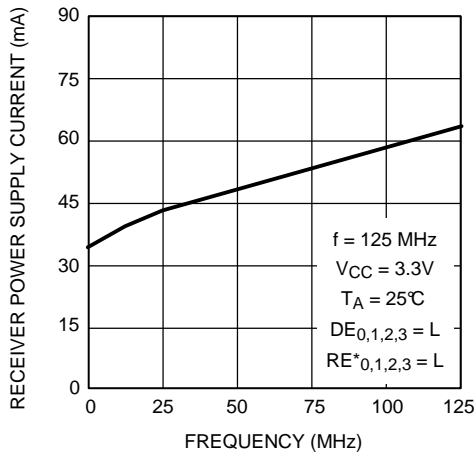

Figure 22. Receiver Power Supply Current as a Function of Frequency

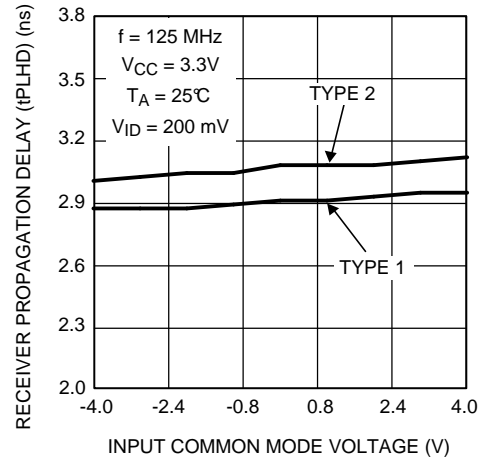

Figure 23. Receiver Propagation Delay (tPLHD) as a Function of Input Common Mode Voltage

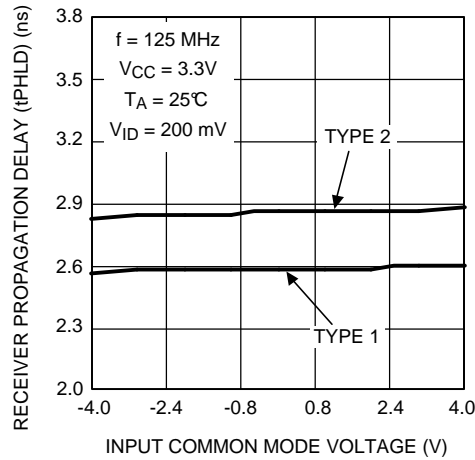

Figure 24. Receiver Propagation Delay (tPHLD) as a Function of Input Common Mode Voltage

REVISION HISTORY**Changes from Revision L (April 2013) to Revision M****Page**

-
- Changed layout of National Data Sheet to TI format [14](#)
-

PACKAGING INFORMATION

Orderable Device	Status (1)	Package Type	Package Drawing	Pins	Package Qty	Eco Plan (2)	Lead/Ball Finish	MSL Peak Temp (3)	Op Temp (°C)	Top-Side Markings (4)	Samples
DS91M040TSQ/NOPB	ACTIVE	WQFN	RTV	32	1000	Green (RoHS & no Sb/Br)	CU SN	Level-3-260C-168 HR	-40 to 85	M040TS	Samples
DS91M040TSQE/NOPB	ACTIVE	WQFN	RTV	32	250	Green (RoHS & no Sb/Br)	CU SN	Level-3-260C-168 HR	-40 to 85	M040TS	Samples
DS91M040TSQX/NOPB	ACTIVE	WQFN	RTV	32	4500	Green (RoHS & no Sb/Br)	CU SN	Level-3-260C-168 HR	-40 to 85	M040TS	Samples

(1) The marketing status values are defined as follows:

ACTIVE: Product device recommended for new designs.

LIFEBUY: TI has announced that the device will be discontinued, and a lifetime-buy period is in effect.

NRND: Not recommended for new designs. Device is in production to support existing customers, but TI does not recommend using this part in a new design.

PREVIEW: Device has been announced but is not in production. Samples may or may not be available.

OBsolete: TI has discontinued the production of the device.

(2) Eco Plan - The planned eco-friendly classification: Pb-Free (RoHS), Pb-Free (RoHS Exempt), or Green (RoHS & no Sb/Br) - please check <http://www.ti.com/productcontent> for the latest availability information and additional product content details.

TBD: The Pb-Free/Green conversion plan has not been defined.

Pb-Free (RoHS): TI's terms "Lead-Free" or "Pb-Free" mean semiconductor products that are compatible with the current RoHS requirements for all 6 substances, including the requirement that lead not exceed 0.1% by weight in homogeneous materials. Where designed to be soldered at high temperatures, TI Pb-Free products are suitable for use in specified lead-free processes.

Pb-Free (RoHS Exempt): This component has a RoHS exemption for either 1) lead-based flip-chip solder bumps used between the die and package, or 2) lead-based die adhesive used between the die and leadframe. The component is otherwise considered Pb-Free (RoHS compatible) as defined above.

Green (RoHS & no Sb/Br): TI defines "Green" to mean Pb-Free (RoHS compatible), and free of Bromine (Br) and Antimony (Sb) based flame retardants (Br or Sb do not exceed 0.1% by weight in homogeneous material)

(3) MSL, Peak Temp. -- The Moisture Sensitivity Level rating according to the JEDEC industry standard classifications, and peak solder temperature.

(4) Multiple Top-Side Markings will be inside parentheses. Only one Top-Side Marking contained in parentheses and separated by a "~" will appear on a device. If a line is indented then it is a continuation of the previous line and the two combined represent the entire Top-Side Marking for that device.

Important Information and Disclaimer: The information provided on this page represents TI's knowledge and belief as of the date that it is provided. TI bases its knowledge and belief on information provided by third parties, and makes no representation or warranty as to the accuracy of such information. Efforts are underway to better integrate information from third parties. TI has taken and continues to take reasonable steps to provide representative and accurate information but may not have conducted destructive testing or chemical analysis on incoming materials and chemicals. TI and TI suppliers consider certain information to be proprietary, and thus CAS numbers and other limited information may not be available for release.

In no event shall TI's liability arising out of such information exceed the total purchase price of the TI part(s) at issue in this document sold by TI to Customer on an annual basis.

TAPE AND REEL INFORMATION

QUADRANT ASSIGNMENTS FOR PIN 1 ORIENTATION IN TAPE



*All dimensions are nominal

Device	Package Type	Package Drawing	Pins	SPQ	Reel Diameter (mm)	Reel Width W1 (mm)	A0 (mm)	B0 (mm)	K0 (mm)	P1 (mm)	W (mm)	Pin1 Quadrant
DS91M040TSQ/NOPB	WQFN	RTV	32	1000	178.0	12.4	5.3	5.3	1.3	8.0	12.0	Q1
DS91M040TSQE/NOPB	WQFN	RTV	32	250	178.0	12.4	5.3	5.3	1.3	8.0	12.0	Q1
DS91M040TSQX/NOPB	WQFN	RTV	32	4500	330.0	12.4	5.3	5.3	1.3	8.0	12.0	Q1

TAPE AND REEL BOX DIMENSIONS

*All dimensions are nominal

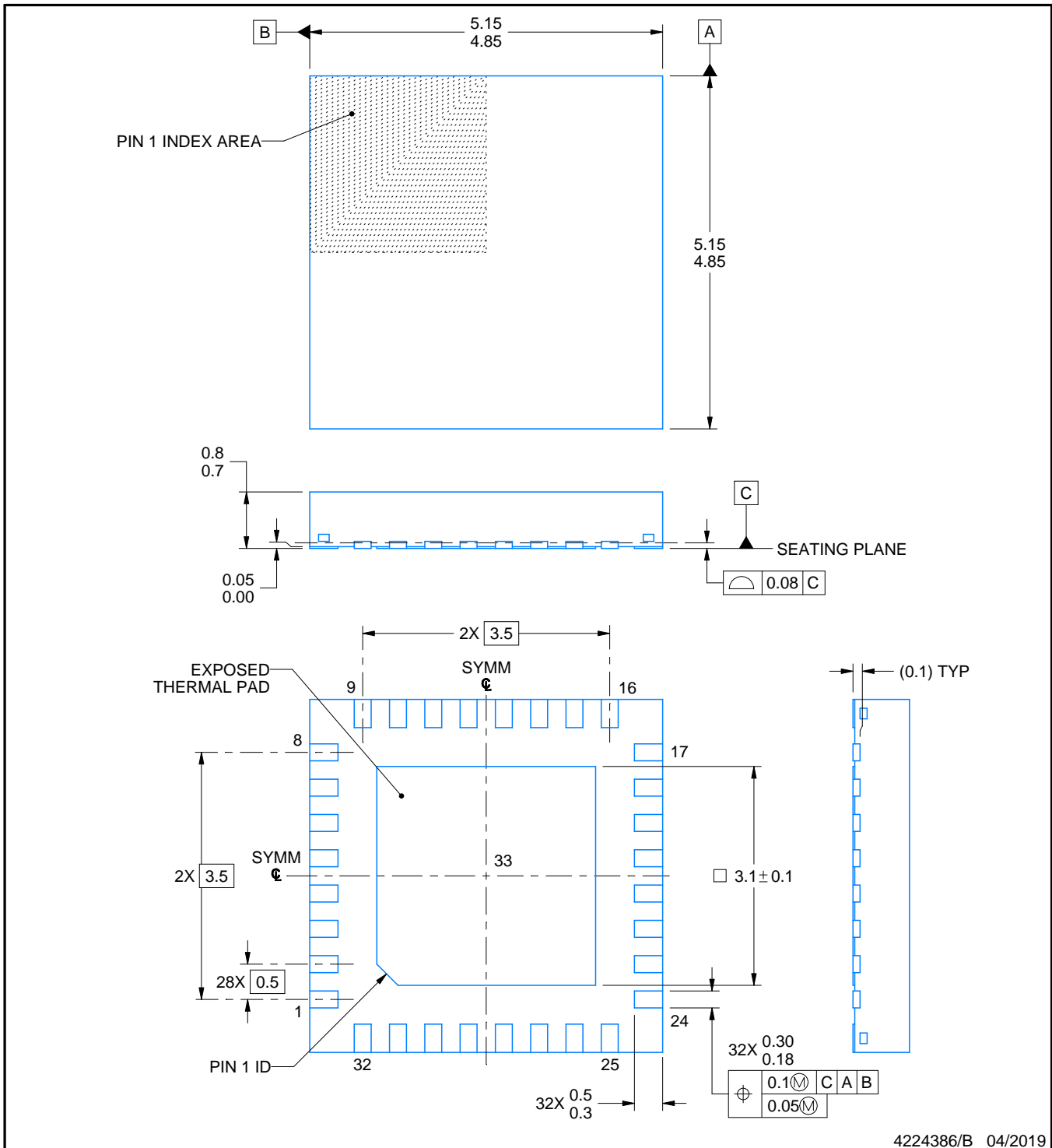
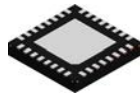
Device	Package Type	Package Drawing	Pins	SPQ	Length (mm)	Width (mm)	Height (mm)
DS91M040TSQ/NOPB	WQFN	RTV	32	1000	210.0	185.0	35.0
DS91M040TSQE/NOPB	WQFN	RTV	32	250	210.0	185.0	35.0
DS91M040TSQX/NOPB	WQFN	RTV	32	4500	367.0	367.0	35.0



NOTES:

1. All linear dimensions are in millimeters. Any dimensions in parenthesis are for reference only. Dimensioning and tolerancing per ASME Y14.5M.
2. This drawing is subject to change without notice.
3. The package thermal pad must be soldered to the printed circuit board for thermal and mechanical performance.

EXAMPLE BOARD LAYOUT

RTV0032A

WQFN - 0.8 mm max height

PLASTIC QUAD FLATPACK - NO LEAD

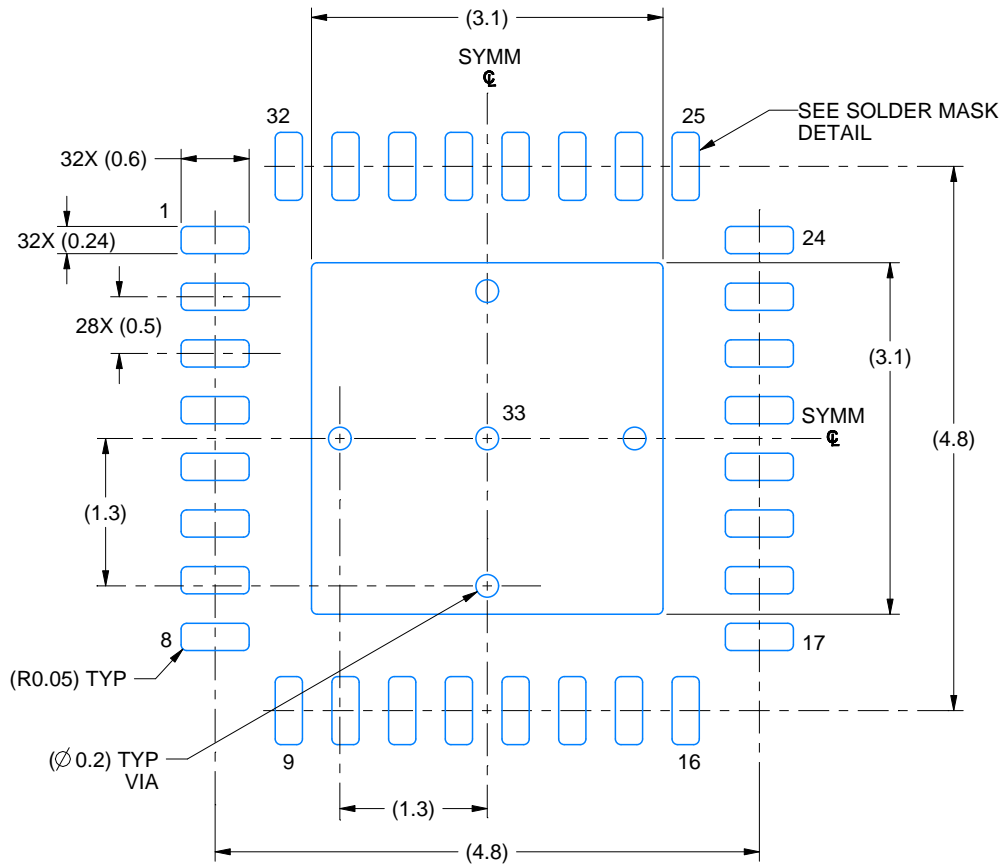

LAND PATTERN EXAMPLE
EXPOSED METAL SHOWN
SCALE: 15X

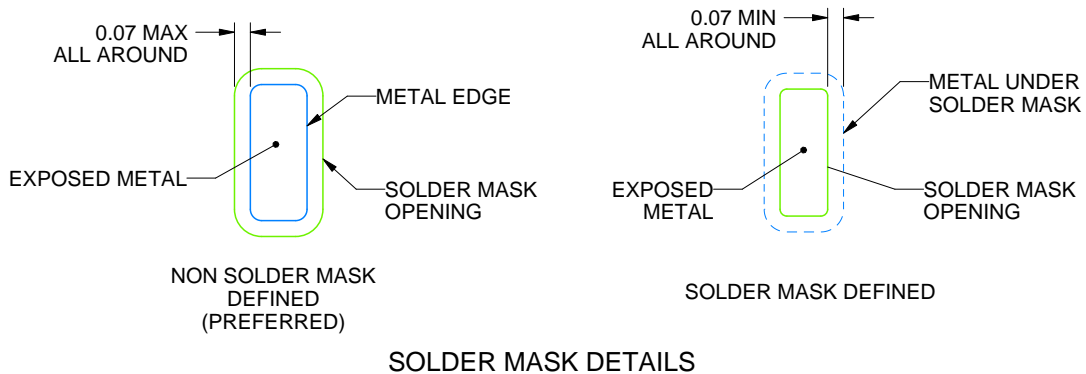

SOLDER MASK DETAILS

4224386/B 04/2019

NOTES: (continued)

4. This package is designed to be soldered to a thermal pad on the board. For more information, see Texas Instruments literature number SLUA271 (www.ti.com/lit/sluea271).
5. Vias are optional depending on application, refer to device data sheet. If any vias are implemented, refer to their locations shown on this view. It is recommended that vias under paste be filled, plugged or tented.

EXAMPLE STENCIL DESIGN

RTV0032A

WQFN - 0.8 mm max height

PLASTIC QUAD FLATPACK - NO LEAD

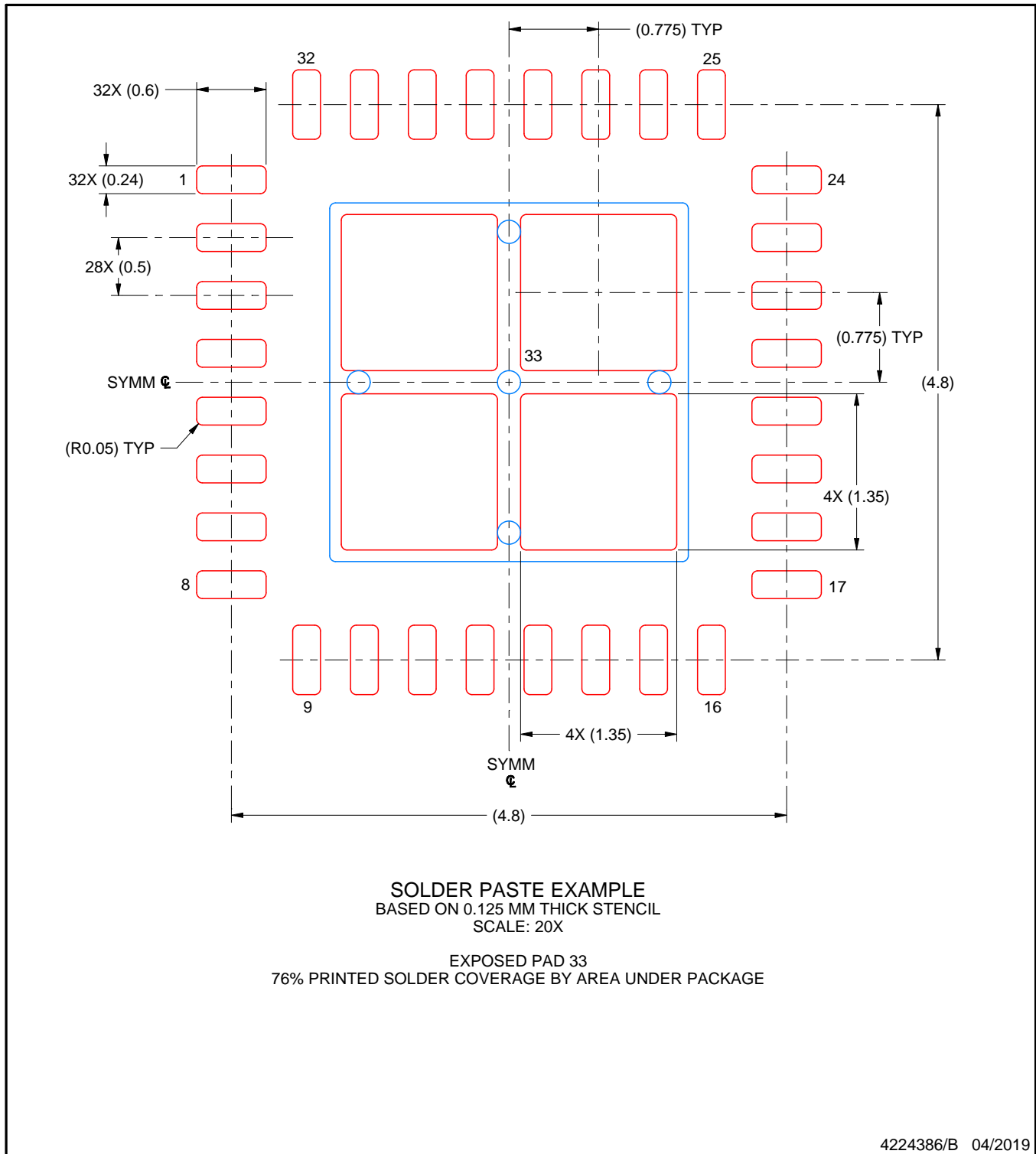

SOLDER PASTE EXAMPLE
BASED ON 0.125 MM THICK STENCIL
SCALE: 20X

EXPOSED PAD 33
76% PRINTED SOLDER COVERAGE BY AREA UNDER PACKAGE

4224386/B 04/2019

NOTES: (continued)

6. Laser cutting apertures with trapezoidal walls and rounded corners may offer better paste release. IPC-7525 may have alternate design recommendations.

IMPORTANT NOTICE AND DISCLAIMER

TI PROVIDES TECHNICAL AND RELIABILITY DATA (INCLUDING DATASHEETS), DESIGN RESOURCES (INCLUDING REFERENCE DESIGNS), APPLICATION OR OTHER DESIGN ADVICE, WEB TOOLS, SAFETY INFORMATION, AND OTHER RESOURCES "AS IS" AND WITH ALL FAULTS, AND DISCLAIMS ALL WARRANTIES, EXPRESS AND IMPLIED, INCLUDING WITHOUT LIMITATION ANY IMPLIED WARRANTIES OF MERCHANTABILITY, FITNESS FOR A PARTICULAR PURPOSE OR NON-INFRINGEMENT OF THIRD PARTY INTELLECTUAL PROPERTY RIGHTS.

These resources are intended for skilled developers designing with TI products. You are solely responsible for (1) selecting the appropriate TI products for your application, (2) designing, validating and testing your application, and (3) ensuring your application meets applicable standards, and any other safety, security, or other requirements. These resources are subject to change without notice. TI grants you permission to use these resources only for development of an application that uses the TI products described in the resource. Other reproduction and display of these resources is prohibited. No license is granted to any other TI intellectual property right or to any third party intellectual property right. TI disclaims responsibility for, and you will fully indemnify TI and its representatives against, any claims, damages, costs, losses, and liabilities arising out of your use of these resources.

TI's products are provided subject to TI's Terms of Sale (www.ti.com/legal/termsofsale.html) or other applicable terms available either on ti.com or provided in conjunction with such TI products. TI's provision of these resources does not expand or otherwise alter TI's applicable warranties or warranty disclaimers for TI products.

Mailing Address: Texas Instruments, Post Office Box 655303, Dallas, Texas 75265
Copyright © 2019, Texas Instruments Incorporated

Looking for pricing, stock, or lifecycle information?

Click below to explore more details on WIN SOURCE:

 [View DS91M040TSQX/NOPB on WIN SOURCE](#)

 [Texas Instruments](#) Information

Optimize Your Supply Chain with WIN SOURCE Solutions

-  Global Sourcing Solution
-  Obsolete Management
-  Cost Control Management
-  Shortage Management
-  Alternative Solution
-  Excess Inventory Management