



**THE DATASHEET OF  
M29W160EB70N6F TR**



# Parallel NOR Flash Embedded Memory

## M29W160ET, M29W160EB

### Features

- Supply voltage
  - $V_{CC} = 2.7\text{--}3.6\text{V}$  (program, erase, read)
- Access times
  - 70, 90ns
- Program time
  - 10 $\mu\text{s}$  per byte/word (TYP)
- Memory organization
  - 3 parameter and 31 main blocks
  - 1 boot block (top or bottom location)
- Program/erase controller
  - Embedded byte/word program algorithms
- Erase suspend and resume capability
  - Read or program another block during an ERASE SUSPEND operation
- UNLOCK BYPASS PROGRAM COMMAND
  - Fast buffered/batch programming
- Temporary block unprotect mode
- Common Flash interface
  - 64-bit security code
- Low power consumption: Standby and automatic mode
- 100,000 PROGRAM/ERASE cycles per block
- Electronic signature
  - Manufacturer code: 0020h
  - Top device code M29W160ET: 22C4h
  - Bottom device code M29W160EB: 2249h
- Packages
  - 48-pin TSOP (N) 12mm x 20mm
  - 48-ball TFBGA (ZA) 6mm x 8mm
  - 64-ball FBGA (ZS) 11mm x 13mm
- Automotive grade parts available

## Part Numbering Information

Devices are shipped from the factory with memory content bits erased to 1. For available options, such as packages or speed, or for further information, contact your Micron sales representative. Part numbers can be verified at [www.micron.com](http://www.micron.com). Feature and specification comparison by device type is available at [www.micron.com/products](http://www.micron.com/products). Contact the factory for devices not found.

**Table 1: Part Number Information**

Part Number Category	Category Details	Notes
Device Type	M29 = Parallel Flash memory	
Operating Voltage	W = 2.7 to 3.6V	
Device function	160E = 16Mb memory array	
Configuration	T = Top boot B = Bottom boot	
Speed	7A = 70ns	1
	70 = 70 ns	2
	80 = 80ns	3
	90 = 90ns	4
Package	N = 48-pin TSOP, 12mm x 20mm	
	ZA = 48-ball TFBGA, 6mm x 8mm, 0.80mm pitch	
	ZS = 64-ball Fortified BGA, 11mm x 13mm, 1mm pitch	
Temperature Range	6 = -40° to 85°C	
	3 = -40°C to 125°C	
Voltage Extension	Blank = Standard option	
	S = $V_{CC,min}$ extension to 2.5V of $V_{CC}$ and available only with 80ns speed class option	
Shipping Options	Blank = Standard packing	
	T = Tape and reel packing	
	E = RoHS-compliant package, standard packing	
	F = RoHS-compliant package, tape and reel packing	

- Notes:
1. Device speed in conjunction with temperature range = 6 to denote automotive grade (-40° to 85°C) parts.
  2. Device speed in conjunction with temperature range = 6 to denote industrial grade (-40° to 85°C) parts, or in conjunction with temperature range = 3 to denote automotive grade (-40° to 125°C) parts.
  3. Access time, automotive device, in conjunction with temperature range = 3 and voltage extension = S.
  4. Device speed in conjunction with temperature range = 6 to denote industrial grade (-40° to 85°C) parts.



## Contents

Important Notes and Warnings .....	7
General Description .....	8
Signal Assignments .....	10
Signal Descriptions .....	13
Memory Organization .....	15
Memory Configuration .....	15
Memory Map, x8 – 16Mb Density .....	15
Memory Map, x16 – 16Mb Density .....	16
Bus Operations .....	17
Read .....	17
Write .....	17
Standby and Automatic Standby .....	17
Output Disable .....	17
Commands .....	18
READ Operations .....	19
READ/RESET Command .....	19
READ CFI Command .....	19
AUTO SELECT Operations .....	20
AUTO SELECT Command .....	20
Read Device ID .....	20
Block and Chip Protection .....	21
BLOCK PROTECT Command .....	21
Block Protection Using Programmer Equipment .....	22
In-System Block Protection .....	24
BYPASS Operations .....	26
UNLOCK BYPASS Command .....	26
UNLOCK BYPASS RESET Command .....	26
PROGRAM Operations .....	26
PROGRAM Command .....	26
UNLOCK BYPASS PROGRAM Command .....	26
ERASE Operations .....	27
CHIP ERASE Command .....	27
BLOCK ERASE Command .....	27
ERASE SUSPEND Command .....	28
ERASE RESUME Command .....	28
Status Register .....	29
Data Polling Bit (DQ7) .....	29
Toggle Bit (DQ6) .....	29
Error Bit (DQ5) .....	29
Erase Timer Bit (DQ3) .....	30
Alternative Toggle Bit (DQ2) .....	30
Absolute Ratings and Operating Conditions .....	33
DC Characteristics .....	35
Read AC Characteristics .....	36
Write AC Characteristics .....	38
Program/Erase Characteristics .....	42
Reset Characteristics .....	43
Package Dimensions .....	44
Revision History .....	47
Rev. C – 2/18 .....	47



## 16Mb: 3V Embedded Parallel NOR Flash Features

---

Rev. B – 06/13 .....	47
Rev. A – 07/12 .....	47

**List of Figures**

Figure 1: Logic Diagram .....	9
Figure 2: 48-Pin TSOP 160ET/B .....	10
Figure 3: 48-Ball TFBGA 160ET/B .....	11
Figure 4: 64-Ball FBGA 160ET/B .....	12
Figure 5: Block Protect Flowchart – Programmer Equipment .....	22
Figure 6: Chip Unprotect Flowchart – Programmer Equipment .....	23
Figure 7: Block Protect Flowchart – In-System Equipment .....	24
Figure 8: Chip Protection Flowchart – In-System Equipment .....	25
Figure 9: Data Polling Flowchart .....	31
Figure 10: Data Toggle Flowchart .....	32
Figure 11: AC Measurement Load Circuit .....	34
Figure 12: AC Measurement I/O Waveform .....	34
Figure 13: Random AC Timing .....	37
Figure 14: WE#-Controlled AC Timing .....	39
Figure 15: CE#-Controlled AC Timing .....	41
Figure 16: Reset/Block Temporary Unprotect AC Waveforms .....	43
Figure 17: 48-Pin TSOP – 12mm x 20mm .....	44
Figure 18: 48-Ball TFBGA – 6mm x 8mm .....	45
Figure 19: 64-Ball FBGA – 11mm x 13mm .....	46



## List of Tables

Table 1: Part Number Information .....	2
Table 2: Signal Names .....	9
Table 3: Signal Descriptions .....	13
Table 4: x8 Top Boot, Blocks [34:0] .....	15
Table 5: x8 Bottom Boot, Blocks [34:0] .....	15
Table 6: x16 Top Boot, Blocks [34:0] .....	16
Table 7: x16 Bottom Boot, Blocks [34:0] .....	16
Table 8: Bus Operations .....	17
Table 9: Commands – 16-Bit Mode (BYTE# = V <sub>IL</sub> ) .....	18
Table 10: Commands – 8-Bit Mode (BYTE# = V <sub>IL</sub> ) .....	18
Table 11: Read Electronic Signature .....	20
Table 12: Block and Chip Protection Signal Settings .....	21
Table 13: Status Register Bits .....	30
Table 14: Absolute Maximum/Minimum Ratings .....	33
Table 15: Operating Conditions .....	33
Table 16: Input/Output Capacitance .....	34
Table 17: DC Current Characteristics .....	35
Table 18: DC Voltage Characteristics .....	35
Table 19: Read AC Characteristics .....	36
Table 20: WE#-Controlled Write AC Characteristics .....	38
Table 21: CE#-Controlled Write AC Characteristics .....	40
Table 22: Program/Erase Times and Endurance Cycles .....	42
Table 23: Reset/Block Temporary Unprotect AC Characteristics .....	43

## Important Notes and Warnings

Micron Technology, Inc. ("Micron") reserves the right to make changes to information published in this document, including without limitation specifications and product descriptions. This document supersedes and replaces all information supplied prior to the publication hereof. You may not rely on any information set forth in this document if you obtain the product described herein from any unauthorized distributor or other source not authorized by Micron.

**Automotive Applications.** Products are not designed or intended for use in automotive applications unless specifically designated by Micron as automotive-grade by their respective data sheets. Distributor and customer/distributor shall assume the sole risk and liability for and shall indemnify and hold Micron harmless against all claims, costs, damages, and expenses and reasonable attorneys' fees arising out of, directly or indirectly, any claim of product liability, personal injury, death, or property damage resulting directly or indirectly from any use of non-automotive-grade products in automotive applications. Customer/distributor shall ensure that the terms and conditions of sale between customer/distributor and any customer of distributor/customer (1) state that Micron products are not designed or intended for use in automotive applications unless specifically designated by Micron as automotive-grade by their respective data sheets and (2) require such customer of distributor/customer to indemnify and hold Micron harmless against all claims, costs, damages, and expenses and reasonable attorneys' fees arising out of, directly or indirectly, any claim of product liability, personal injury, death, or property damage resulting from any use of non-automotive-grade products in automotive applications.

**Critical Applications.** Products are not authorized for use in applications in which failure of the Micron component could result, directly or indirectly in death, personal injury, or severe property or environmental damage ("Critical Applications"). Customer must protect against death, personal injury, and severe property and environmental damage by incorporating safety design measures into customer's applications to ensure that failure of the Micron component will not result in such harms. Should customer or distributor purchase, use, or sell any Micron component for any critical application, customer and distributor shall indemnify and hold harmless Micron and its subsidiaries, subcontractors, and affiliates and the directors, officers, and employees of each against all claims, costs, damages, and expenses and reasonable attorneys' fees arising out of, directly or indirectly, any claim of product liability, personal injury, or death arising in any way out of such critical application, whether or not Micron or its subsidiaries, subcontractors, or affiliates were negligent in the design, manufacture, or warning of the Micron product.

**Customer Responsibility.** Customers are responsible for the design, manufacture, and operation of their systems, applications, and products using Micron products. ALL SEMICONDUCTOR PRODUCTS HAVE INHERENT FAILURE RATES AND LIMITED USEFUL LIVES. IT IS THE CUSTOMER'S SOLE RESPONSIBILITY TO DETERMINE WHETHER THE MICRON PRODUCT IS SUITABLE AND FIT FOR THE CUSTOMER'S SYSTEM, APPLICATION, OR PRODUCT. Customers must ensure that adequate design, manufacturing, and operating safeguards are included in customer's applications and products to eliminate the risk that personal injury, death, or severe property or environmental damages will result from failure of any semiconductor component.

**Limited Warranty.** In no event shall Micron be liable for any indirect, incidental, punitive, special or consequential damages (including without limitation lost profits, lost savings, business interruption, costs related to the removal or replacement of any products or rework charges) whether or not such damages are based on tort, warranty, breach of contract or other legal theory, unless explicitly stated in a written agreement executed by Micron's duly authorized representative.

## General Description

The M29W160ET/B (2Mb x8 or 1Mb x16) is a nonvolatile device that can be read, erased and reprogrammed. These operations can be performed using a single low voltage (2.7–3.6V) supply. On power-up the memory defaults to read mode where it can be read in the same way as a ROM or EPROM.

The device is divided into blocks that can be erased independently to preserve valid data while old data is erased. Each block can be protected independently to prevent accidental PROGRAM or ERASE commands from modifying the memory. PROGRAM and ERASE commands are written to the command interface of the memory. An on-chip program/erase controller simplifies the process of programming or erasing the memory by taking care of all of the special operations that are required to update the memory contents.

The end of a PROGRAM or ERASE operation can be detected and any error conditions identified. The command set required to control the memory is consistent with JEDEC standards.

The blocks in the memory are asymmetrically arranged. The first or last 64KB have been divided into four additional blocks. The 16KB boot block can be used for a small initialization code to start the microprocessor, the two 8 KB parameter blocks can be used for parameter storage, and the remaining 32KB is a small main block where the application may be stored.

CE#, OE#, and WE# signals control the bus operation. They enable simple connection to most microprocessors, often without additional logic.

The device supplied with all the bits erased (set to 1).

**Figure 1: Logic Diagram**

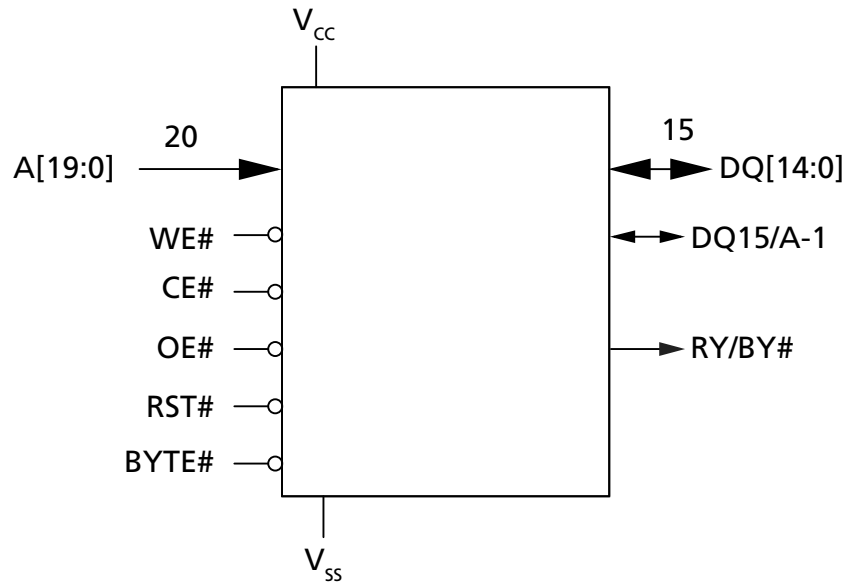
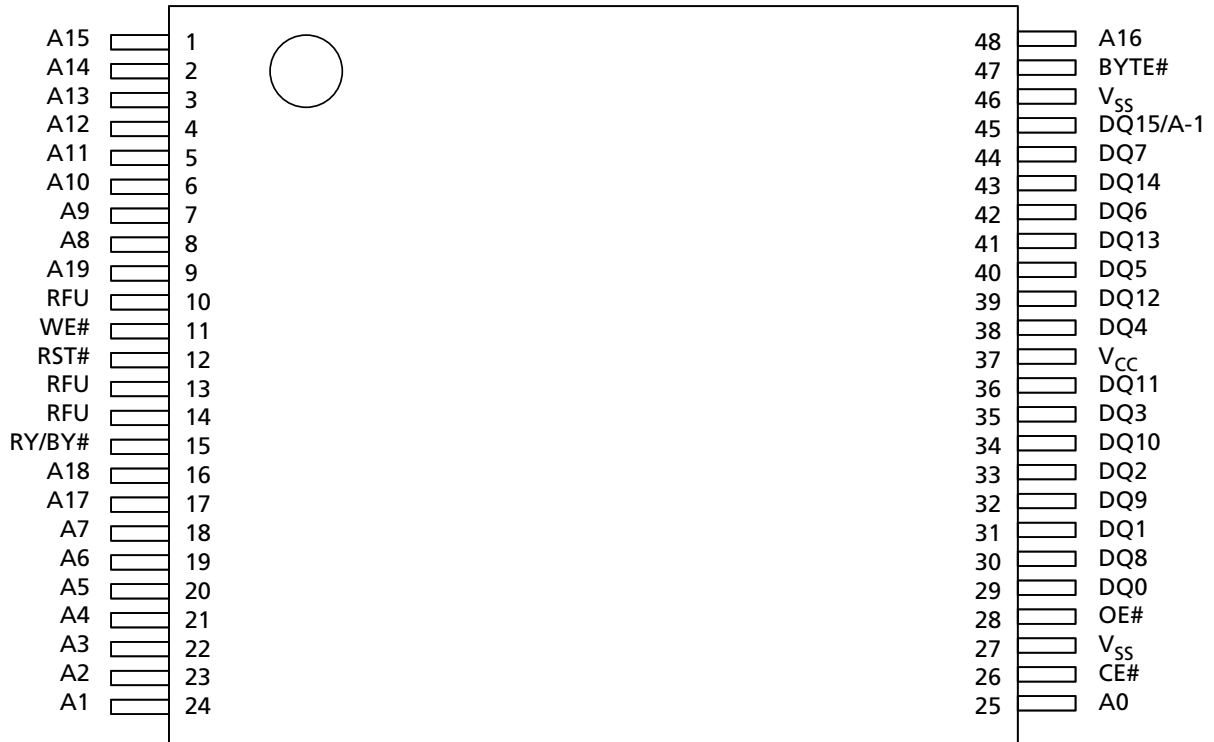

**Table 2: Signal Names**

Name	Description	Type
A[19:0]	Address inputs	Input
CE#	Chip enable	Input
OE#	Output enable	Input
WE#	Write enable	Input
BYTE#	Byte/word organization select	Input
RST#	Reset/block temporary unprotect	Input
DQ[7:0]	Data I/O	I/O
DQ[14:8]	Data I/O	I/O
DQ15/A-1	Data I/O or address input	I/O
RY/BY#	Ready/busy output	Output
V <sub>CC</sub>	Core power supply	Supply
V <sub>SS</sub>	Ground	Supply
NC	Not connected internally	-

## Signal Assignments

Figure 2: 48-Pin TSOP 160ET/B



Note: 1. RFU = reserved for future use.

**Figure 3: 48-Ball TFBGA 160ET/B**

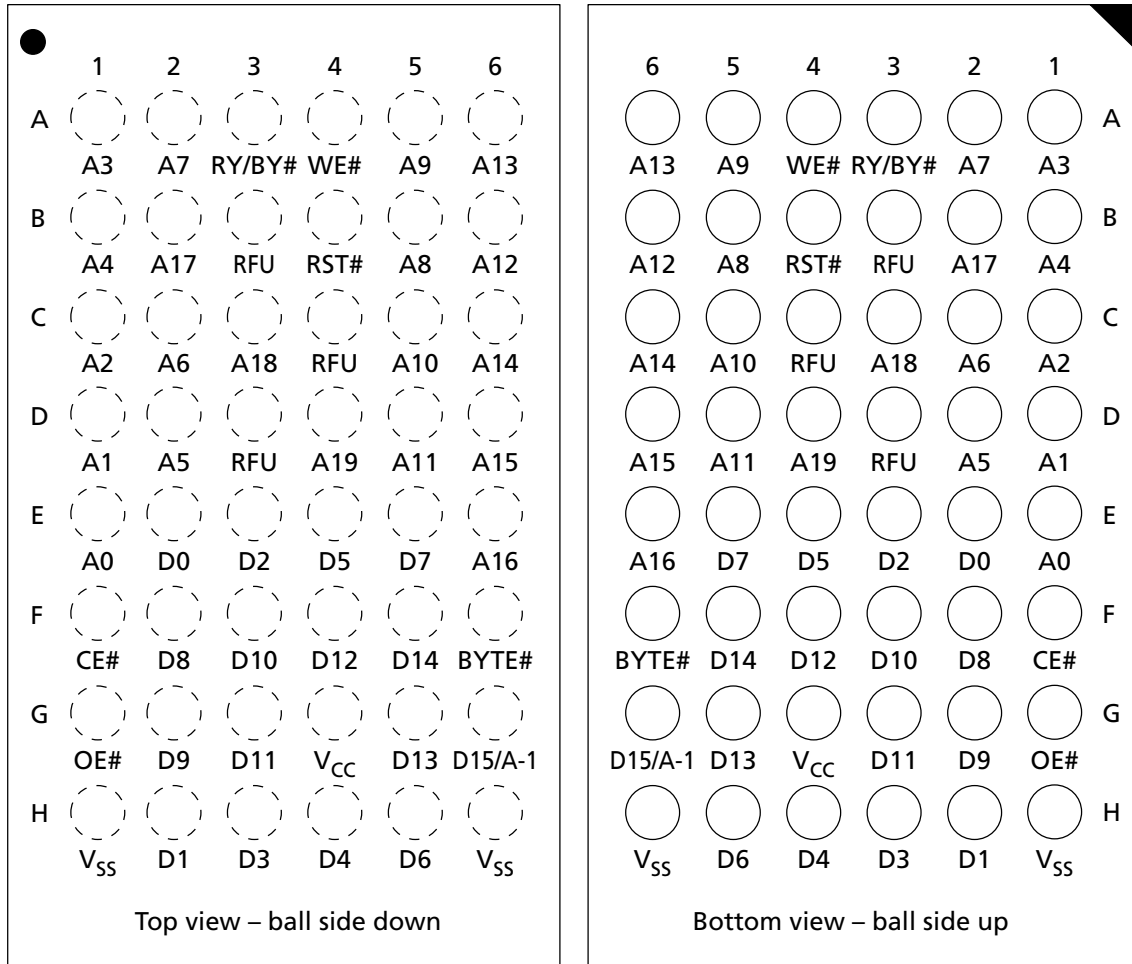

Note: 1. RFU = reserved for future use.

**Figure 4: 64-Ball FBGA 160ET/B**

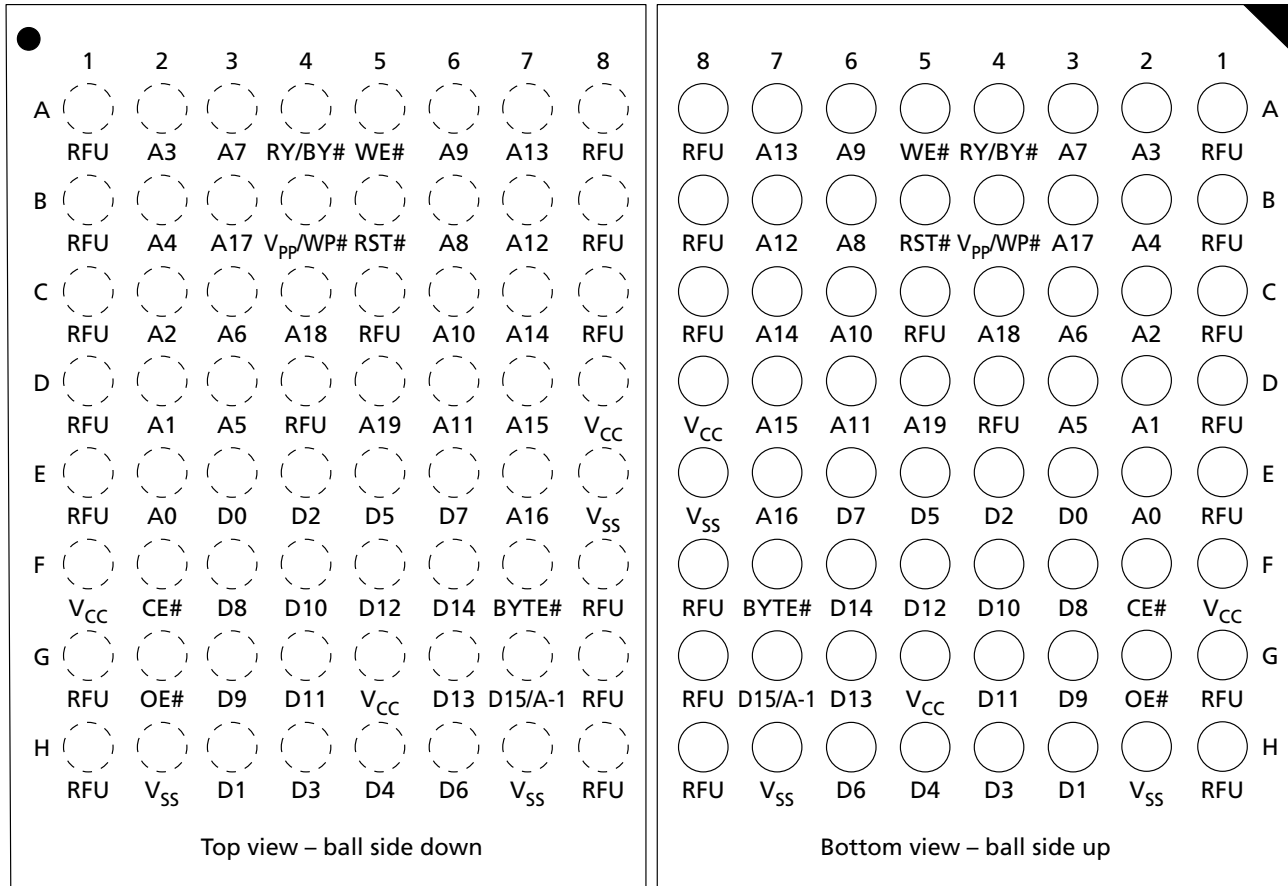

Note: 1. RFU = reserved for future use.

## Signal Descriptions

The table below is a comprehensive list of signals for this device family. All signals listed may not be supported on this device. See Signal Assignments for information specific to this device.

**Table 3: Signal Descriptions**

Name	Type	Description
A[MAX:0]	Input	<b>Address:</b> Selects the cells in the memory array to access during READ operations. During WRITE operations, controls the commands sent to the command interface of the program/erase controller.
CE#	Input	<b>Chip enable:</b> Activates the memory, enabling READ and WRITE operations. When CE# is HIGH, all other pins are ignored.
OE#	Input	<b>Output enable:</b> Controls the bus READ operation of the memory.
WE#	Input	<b>Write enable:</b> Controls the bus WRITE operation of the command interface.
BYTE#	Input	<b>Byte/word organization select:</b> Switches between x8 and x16 bus modes. When BYTE# is LOW, the device is in x8 mode; when HIGH, the device is in x16 mode.
RST#	Input	<b>Reset/block temporary unprotect:</b> Applies a hardware reset to the memory or temporarily removes protection from all blocks that have been protected. A hardware reset is achieved by holding RST# LOW for at least $t_{PLPX}$ . When RST# goes HIGH, the memory is ready for READ and WRITE operations after $t_{PHEL}$ or $t_{RHEL}$ , whichever occurs last.  Holding RST# at $V_{ID}$ temporarily unprotects the protected blocks so that PROGRAM and ERASE operations are possible on all blocks. The transition from HIGH to $V_{ID}$ must be slower than $t_{PHPHH}$ .
DQ[7:0]	I/O	<b>Data I/O:</b> Outputs the data stored at the selected address during READ operations. During WRITE operations, represents the commands sent to the command interface of the program/erase controller.
DQ[14:8]	I/O	<b>Data I/O:</b> Outputs data stored at the selected address during a READ operation when BYTE# is HIGH. When BYTE# is LOW, these pins are not used and are High-Z. During a WRITE operation, the command register does not use these bits. When reading the status register, these bits should be ignored.
DQ15/A-1	I/O	<b>Data I/O or address input:</b> When BYTE# is HIGH, this pin behaves as a data I/O pin, DQ[14:8]. When BYTE# is LOW, this pin behaves as an address pin; DQ15/A-1 LOW selects the LSB of the word on the other addresses, DQ15/A-1 HIGH selects the MSB. Throughout the text, consider references to data I/O to include this pin when BYTE# is HIGH and consider references to address inputs to include this pin when BYTE# is LOW, except when stated explicitly otherwise.
RY/BY#	Output	<b>Ready/busy:</b> Open-drain output that can be used to identify when the device can be read. RY/BY# is High-Z during read, auto select, and erase suspend modes. After a hardware reset, a READ or WRITE operation cannot begin until RY/BY# becomes High-Z. During a PROGRAM or ERASE operation, RY/BY# is LOW and remains LOW during READ/RESET commands or hardware resets until the memory is ready to enter read mode. The use of an open-drain output enables the RY/BY# pins from several memory devices to be connected to a single pull-up resistor. A LOW indicates that one or more of the devices is busy.

**Table 3: Signal Descriptions (Continued)**

Name	Type	Description
V <sub>CC</sub>	Supply	<b>Supply voltage:</b> Provides the power supply for device operations. The command interface is disabled when V <sub>CC</sub> ≤ V <sub>LKO</sub> . This prevents a WRITE operation from accidentally damaging the data during power-up, power-down, and power surges. If the program/erase controller is programming or erasing during this time, the operation aborts, and the contents being altered will be invalid. See Note 1.
V <sub>SS</sub>	Supply	<b>Ground:</b> All V <sub>SS</sub> pins must be connected to the system ground.
RFU	–	<b>Reserved for future use:</b> RFUs should be not connected.

- Note: 1. A 0.1μF capacitor should be connected between V<sub>CC</sub> and V<sub>SS</sub> to decouple the current surges from the power supply. The PCB track widths must be sufficient to carry the currents required during PROGRAM and ERASE operations.

## Memory Organization

### Memory Configuration

The main memory array is divided into 64KB blocks.

The blocks in the memory are asymmetrically arranged. The first or last 64KB of memory has been divided into four additional blocks. The 16KB boot block can be used for small initialization code to start the microprocessor, the two 8KB parameter blocks can be used for parameter storage and the remaining 32KB small main block can be used for application storage.

### Memory Map, x8 – 16Mb Density

**Table 4: x8 Top Boot, Blocks [34:0]**

Block	Block Size	Address Range	
		Start	End
34	16KB	001F C000	001F FFFF
33	8KB	001F A000	001F BFFF
32	8KB	001F 8000	001F 9FFF
31	32KB	001F 0000	001F 7FFF
30	64KB	001E 0000	001E FFFF
⋮	⋮	⋮	⋮
2	64KB	0002 0000	0002 FFFF
1	64KB	0001 0000	0001 FFFF
0	64KB	0000 0000	0000 FFFF

**Table 5: x8 Bottom Boot, Blocks [34:0]**

Block	Block Size	Address Range	
		Start	End
34	64KB	001F 0000	001F FFFF
33	64KB	001E 0000	001E FFFF
32	64KB	001D 0000	001D FFFF
⋮	⋮	⋮	⋮
4	64KB	0001 0000	0001 FFFF
3	32KB	0000 8000	0000 FFFF
2	8KB	0000 6000	0000 7FFF
1	8KB	0000 4000	0000 5FFF
0	16KB	0000 0000	0000 3FFF



**Memory Map, x16 – 16Mb Density**

**Table 6: x16 Top Boot, Blocks [34:0]**

Block	Block Size	Address Range	
		Start	End
34	8KW	000F E000	000F FFFF
33	4KW	000F D000	000F DFFF
32	4KW	000F C000	000F CFFF
31	16KW	000F 8000	000F BFFF
30	32KW	001E 0000	001E FFFF
⋮	⋮	⋮	⋮
2	32KW	0001 0000	0001 7FFF
1	32KW	0008 0000	0000 FFFF
0	32KW	0000 0000	0000 7FFF

**Table 7: x16 Bottom Boot, Blocks [34:0]**

Block	Block Size	Address Range	
		Start	End
34	32KW	000F 8000	000F FFFF
33	32KW	000F 0000	000F 7FFF
32	32KW	000E 8000	000E FFFF
⋮	⋮	⋮	⋮
4	32KW	0000 8000	0000 FFFF
3	16KW	0000 4000	0000 7FFF
2	4KW	0000 3000	0000 3FFF
1	4KW	0000 2000	0000 2FFF
0	8KW	0000 0000	0000 1FFF

## Bus Operations

**Table 8: Bus Operations**

Notes 1 and 2 apply to entire table

Operation	CE#	OE#	WE#	8-Bit Mode			16-Bit Mode	
				A[MAX:0], DQ15/A-1	DQ[14:8]	DQ[7:0]	A[MAX:0]	DQ15/A-1, DQ[14:0]
READ	L	L	H	Cell address	High-Z	Data output	Cell address	Data output
WRITE	L	H	L	Command address	High-Z	Data input <sup>4</sup>	Command address	Data input <sup>4</sup>
STANDBY	H	X	X	X	High-Z	High-Z	X	High-Z
OUTPUT DISABLE	X	H	H	X	High-Z	High-Z	X	High-Z

- Notes:
1. Typical glitches of less than 5ns on CE# and WE# are ignored by the device and do not affect bus operations.
  2. H = Logic level HIGH ( $V_{IH}$ ); L = Logic level LOW ( $V_{IL}$ ); X = HIGH or LOW.
  3. If WP# = LOW, the highest/lowest block remains protected, depending on the line item.
  4. Data input is required when issuing a command sequence or performing data polling or block protection.

### Read

Bus READ operations read from the memory cells, registers, or CFI space. A valid READ operation requires setting the appropriate address on the address inputs, taking CE# and OE# LOW and holding WE# HIGH. Data I/O signals output the value.

### Write

Bus WRITE operations write to the command interface. A valid WRITE operation requires setting the appropriate address on the address inputs. These are latched by the command interface on the falling edge of CE# or WE#, whichever occurs last. Values on data I/O signals are latched by the command interface on the rising edge of CE# or WE#, whichever occurs first. OE# must remain HIGH during the entire operation.

### Standby and Automatic Standby

When the device is in read mode, driving CE# HIGH places the device in standby mode and drives data I/Os to High-Z. Supply current is reduced to standby ( $I_{CC2}$ ), by holding CE# within  $V_{CC} \pm 0.2V$ .

During PROGRAM or ERASE operations, the device continues to use the program/erase supply current ( $I_{CC3}$ ) until the operation completes.

Automatic standby enables low power consumption during read mode. When CMOS levels ( $V_{CC} \pm 0.2V$ ) drive the bus, and following a READ operation and a period of inactivity specified in DC Characteristics, the memory enters automatic standby as internal supply current is reduced to  $I_{CC2}$ . Data I/O signals still output data if a READ operation is in progress.

### Output Disable

Data I/Os are High-Z when OE# is HIGH.

## Commands

All bus WRITE operations to the memory are interpreted by the command interface. Commands consist of one or more sequential bus WRITE operations. Failure to observe a valid sequence of bus WRITE operations will result in the memory returning to read mode. The long command sequences are imposed to maximize data security.

The address used for the commands changes, depending on whether the memory is in 16-bit or 8-bit mode. See the x8 and x16 command tables, depending on the configuration that is being used, for a summary of the commands.

**Table 9: Commands – 16-Bit Mode (BYTE# = V<sub>IL</sub>)**

Command	Length	Bus WRITE Operations											
		1st		2nd		3rd		4th		5th		6th	
		Addr	Data	Addr	Data	Addr	Data	Addr	Data	Addr	Data	Addr	Data
READ/RESET	1	X	F0										
	3	555	AA	2AA	55	X	F0						
AUTO SELECT	3	555	AA	2AA	55	555	90						
PROGRAM	4	555	AA	2AA	55	555	A0	PA	PD				
UNLOCK BY-PASS	3	555	AA	2AA	55	555	20						
UNLOCK BY-PASS PROGRAM	2	X	A0	PA	PD								
UNLOCK BY-PASS RESET	2	X	90	X	00								
CHIP ERASE	6	555	AA	2AA	55	555	80	555	AA	2AA	55	555	10
BLOCK ERASE	6+	555	AA	2AA	55	555	80	555	AA	2AA	55	BA	30
ERASE SUSPEND	1	X	B0										
ERASE RESUME	1	X	30										
READ CFI QUERY	1	55	98										

Note: 1. X = " Don't Care;" PA = Program address; PD = Program data; BA = Any address in the block. All values in the table are in hexadecimal. The command interface only uses A-1, A0–A10, and DQ0–DQ7 to verify the commands; A11–A20, DQ8–DQ14, and DQ15 are "Don't Care." DQ15A-1 is A-1 when BYTE# is V<sub>IL</sub> or DQ15 when BYTE# is V<sub>IH</sub>.

**Table 10: Commands – 8-Bit Mode (BYTE# = V<sub>IL</sub>)**

Command	Length	Bus WRITE Operations											
		1st		2nd		3rd		4th		5th		6th	
		Addr	Data	Addr	Data	Addr	Data	Addr	Data	Addr	Data	Addr	Data
READ/RESET	1	X	F0										
	3	AAA	AA	555	55	X	F0						
AUTO SELECT	3	AAA	AA	555	55	AAA	90						

**Table 10: Commands – 8-Bit Mode (BYTE# = V<sub>IL</sub>) (Continued)**

Command	Length	Bus WRITE Operations											
		1st		2nd		3rd		4th		5th		6th	
		Addr	Data	Addr	Data	Addr	Data	Addr	Data	Addr	Data	Addr	Data
PROGRAM	4	AAA	AA	555	55	AAA	A0	PA	PD				
UNLOCK BY-PASS	3	AAA	AA	555	55	AAA	20						
UNLOCK BY-PASS PROGRAM	2	X	A0	PA	PD								
UNLOCK BY-PASS RESET	2	X	90	X	00								
CHIP ERASE	6	AAA	AA	555	55	AAA	80	AAA	AA	555	55	AAA	10
BLOCK ERASE	6+	AAA	AA	555	55	AAA	80	AAA	AA	555	55	BA	30
ERASE SUSPEND	1	X	B0										
ERASE RESUME	1	X	30										
READ CFI QUERY	1	55	98										

Note: 1. X = " Don't Care;" PA = Program address; PD = Program data; BA = Any address in the block. All values in the table are in hexadecimal. The command interface only uses A-1, A0-A10, and DQ0-DQ7 to verify the commands; A11-A20, DQ8-DQ14, and DQ15 are "Don't Care." DQ15A-1 is A-1 when BYTE# is V<sub>IL</sub> or DQ15 when BYTE# is V<sub>IH</sub>.

## READ Operations

### READ/RESET Command

The READ/RESET (F0h) command returns the device to read mode and resets the errors in the status register. One or three bus WRITE operations can be used to issue the READ/RESET command.

To return the device to read mode, this command can be issued between bus WRITE cycles before the start of a PROGRAM or ERASE operation. If the READ/RESET command is issued during the timeout of a BLOCK ERASE operation, the device requires up to 10μs to abort, during which time no valid data can be read.

### READ CFI Command

The READ CFI (98h) command puts the device in read CFI mode and is valid only when the device is in read array or auto select mode. One bus WRITE cycle is required to issue the command.

Once in read CFI mode, bus READ operations will output data from the CFI memory area. A READ/RESET command must be issued to return the device to the previous mode (read array or auto select ). A second READ/RESET command is required to put the device in read array mode from auto select mode.

## AUTO SELECT Operations

### AUTO SELECT Command

At power-up or after a hardware reset, the device is in read mode. It can then be put in auto select mode by issuing an AUTO SELECT (90h) command or by applying  $V_{ID}$  to A9. Auto select mode enables the following device information to be read:

- Electronic signature, which includes manufacturer and device code information, as shown in the Read Electronic Signature table.
- Block protection, which includes the block protection status and extended memory block protection indicator, as shown in the Block Protection table.

Electronic signature or block protection information is read by executing a READ operation with control signals and addresses set.

Auto select mode can be used by the programming equipment to automatically match a device with the application code to be programmed.

Three consecutive bus WRITE operations are required to issue an AUTO SELECT command. The device remains in auto select mode until a READ/RESET or READ CFI command is issued.

The device cannot enter auto select mode when a PROGRAM or ERASE operation is in progress (RY/BY# LOW). However, auto select mode can be entered if the PROGRAM or ERASE operation has been suspended by issuing a PROGRAM SUSPEND or ERASE SUSPEND command.

Auto select mode is exited by performing a reset. The device returns to read mode unless it entered auto select mode after an ERASE SUSPEND or PROGRAM SUSPEND command, in which case it returns to erase or program suspend mode.

## Read Device ID

**Table 11: Read Electronic Signature**

Note 1 applies to entire table

READ Cycle	CE#	OE#	WE#	Address Input					Data I/O		
				8-Bit/16-Bit					8-Bit Only		16-Bit Only
				A[MAX:10]	A9	A[8:2]	A1	A0	DQ[14:8]	DQ[7:0]	DQ[15]/A-1, DQ[14:0]
Manufacturer code	L	L	H	X	$V_{ID}$	X	L	L	High-Z	20h	0020h
Device code	L	L	H	X	$V_{ID}$	X	L	H	High-Z	C4h <sup>2</sup> 49h <sup>3</sup>	22C4h <sup>2</sup> 2249h <sup>3</sup>

- Notes:
1. H = Logic level HIGH ( $V_{IH}$ ); L = Logic level LOW ( $V_{IL}$ ); X = HIGH or LOW.
  2. M29W160ET.
  3. M29W160EB.

## Block and Chip Protection

Block protection can be used to prevent any operation from modifying the data stored in the Flash. Each block can be protected individually. Once protected, PROGRAM and ERASE operations on the block fail to change the data.

Do not allow microprocessor service interrupts to interfere with timing, and do not abort an operation before its completion. The CHIP UNPROTECT operation can take several seconds, and a user message should be provided to show progression. (Refer to the following flowcharts for details.)

Unlike the command interface of the program/erase controller, techniques for protecting and unprotecting blocks change from one Flash memory supplier to another. Care should be taken when changing drivers for one part to work on another.

### BLOCK PROTECT Command

There are three techniques that can be used to control block protection. These are programmer technique, in-system technique, and temporary unprotect. Temporary unprotect is controlled by RST#.

Unlike the command interface of the program/erase controller, the techniques for protecting and unprotecting blocks change between different Flash memory suppliers.

**Table 12: Block and Chip Protection Signal Settings**

Signals	Block Protect	Chip Unprotect	Verify Block Protection	Verify Block Unprotect
CE#	L	V <sub>ID</sub>	L	L
OE#	V <sub>ID</sub>	V <sub>ID</sub>	L	L
WE#	L pulse	L pulse	H	H
Address Input, 8-Bit and 16-Bit				
A[ <b>MAX:16</b> ]	Block base address	X	Block base address	Block base address
A15		H		
A14		X		
A13		X		
A12		H		
A11	X	X	X	X
A10	X	X	X	X
A9	V <sub>ID</sub>	V <sub>ID</sub>	V <sub>ID</sub>	V <sub>ID</sub>
A8	X	X	X	X
A7	X	X	X	X
A6	X	X	L	H
A5	X	X	X	X
A4	X	X	X	X
A3	X	X	X	X
A2	X	X	X	X
A1	X	X	H	H

**Table 12: Block and Chip Protection Signal Settings (Continued)**

Signals	Block Protect	Chip Unprotect	Verify Block Protection	Verify Block Unprotect
A0	X	X	L	L
<b>Data I/O, 8-Bit and 16-Bit</b>				
DQ[15]/A-1, and DQ[14:0]	X	X	Pass = XX01h	Retry = XX01h
	X	X	Retry = XX00h	Pass = XX00h

Note: 1. H = Logic level HIGH ( $V_{IH}$ ); L = Logic level LOW ( $V_{IL}$ ); X = HIGH or LOW.

### Block Protection Using Programmer Equipment

The programmer technique uses high voltage levels ( $V^{ID}$ ) on some of the bus pins. These cannot be achieved using a standard microprocessor bus; therefore, the technique is recommended only for use in programming equipment.

To protect a block, follow the steps in the following figure. To unprotect the whole chip, it is necessary to protect all of the blocks first, then all blocks can be unprotected at the same time.

**Figure 5: Block Protect Flowchart – Programmer Equipment**

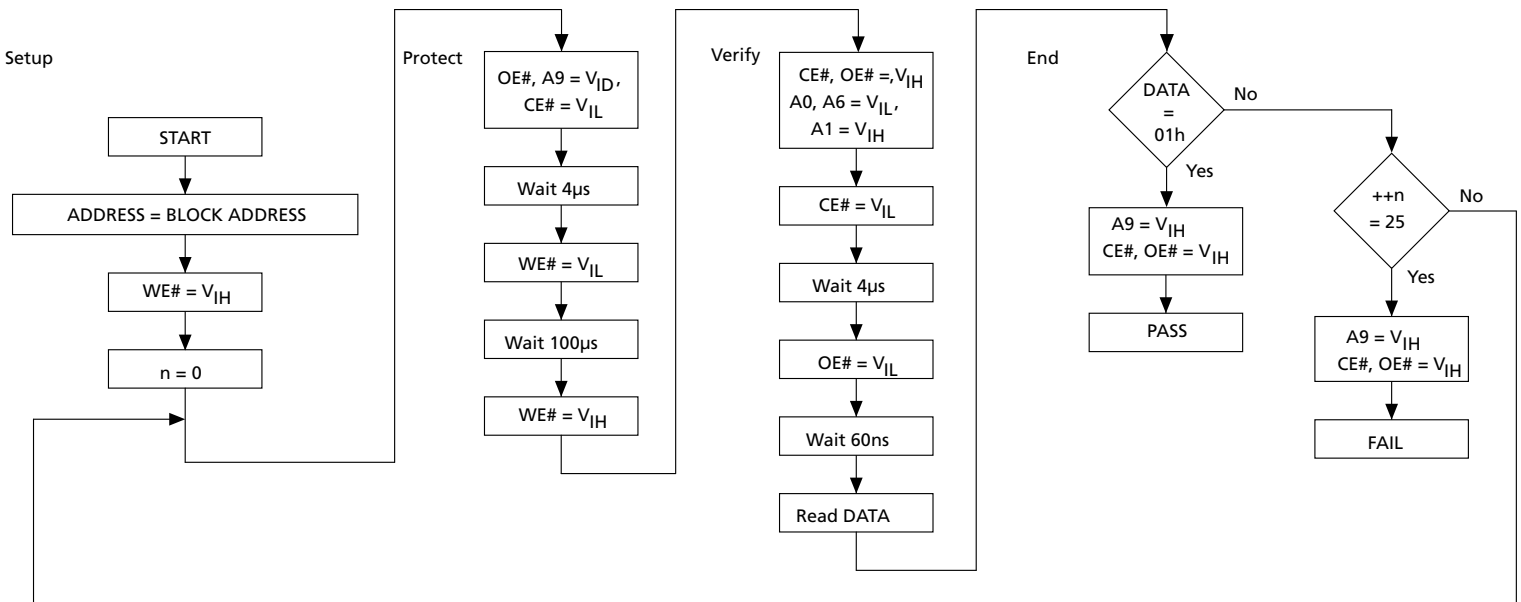

**Figure 6: Chip Unprotect Flowchart – Programmer Equipment**

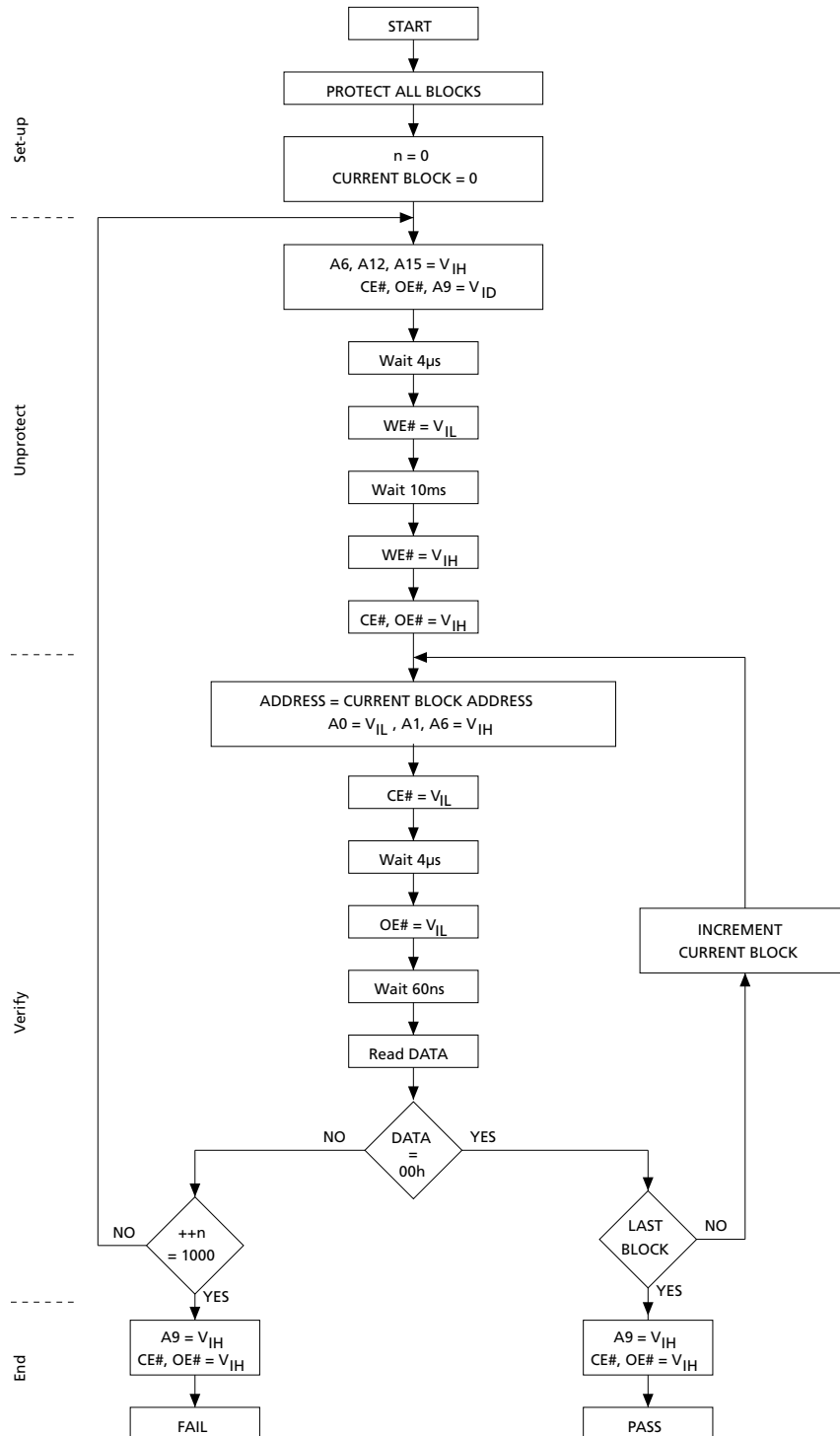

- Notes:
1. Address Inputs A[9:12] give the address of the block that is to be protected. It is imperative that they remain stable during the operation.
  2. During the protect and verify phases of the algorithm, CE# must be kept LOW.

## In-System Block Protection

The in-system technique requires a high-voltage level on RST#. This can be achieved without violating the maximum ratings of the components on the microprocessor bus; therefore, this technique is suitable for use after the Flash has been fitted to the system.

To protect a block, follow the steps in the following figure. To unprotect the whole chip, it is necessary to protect all of the blocks first, then all the blocks can be unprotected at the same time.

**Figure 7: Block Protect Flowchart – In-System Equipment**

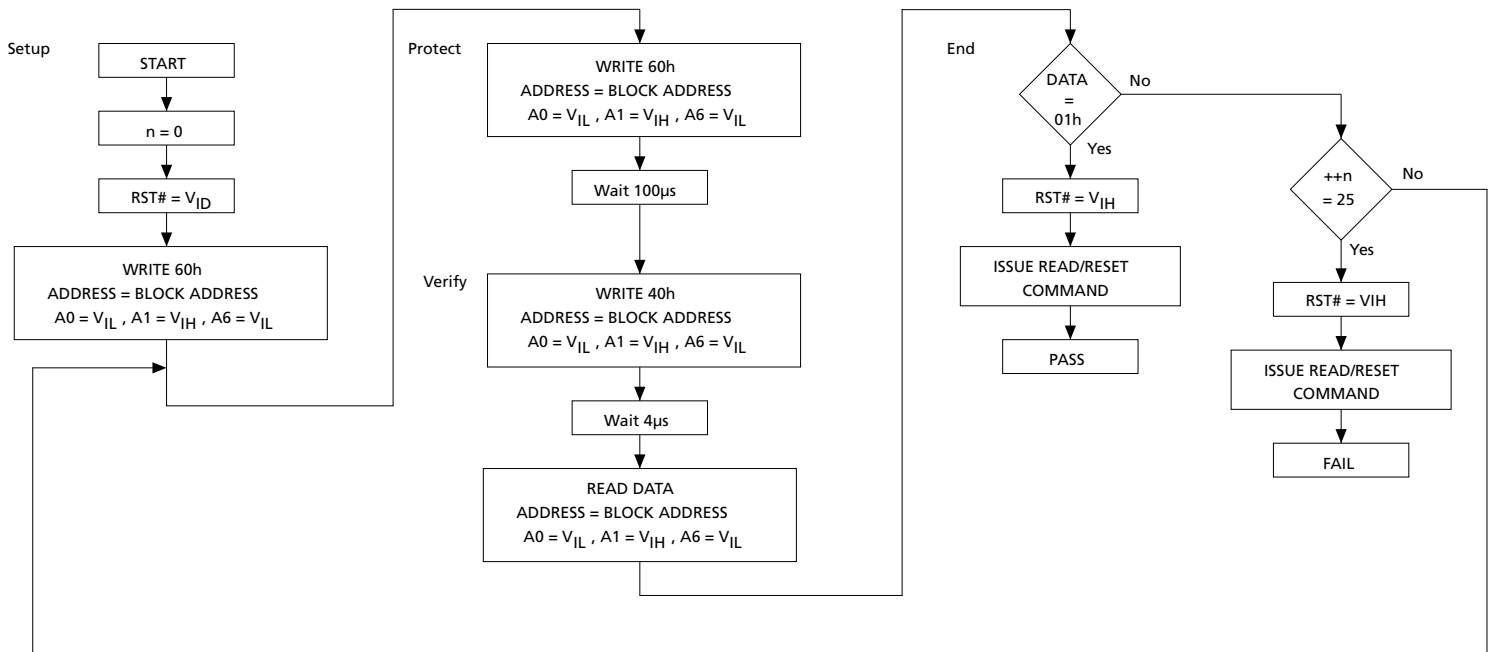

**Figure 8: Chip Protection Flowchart – In-System Equipment**

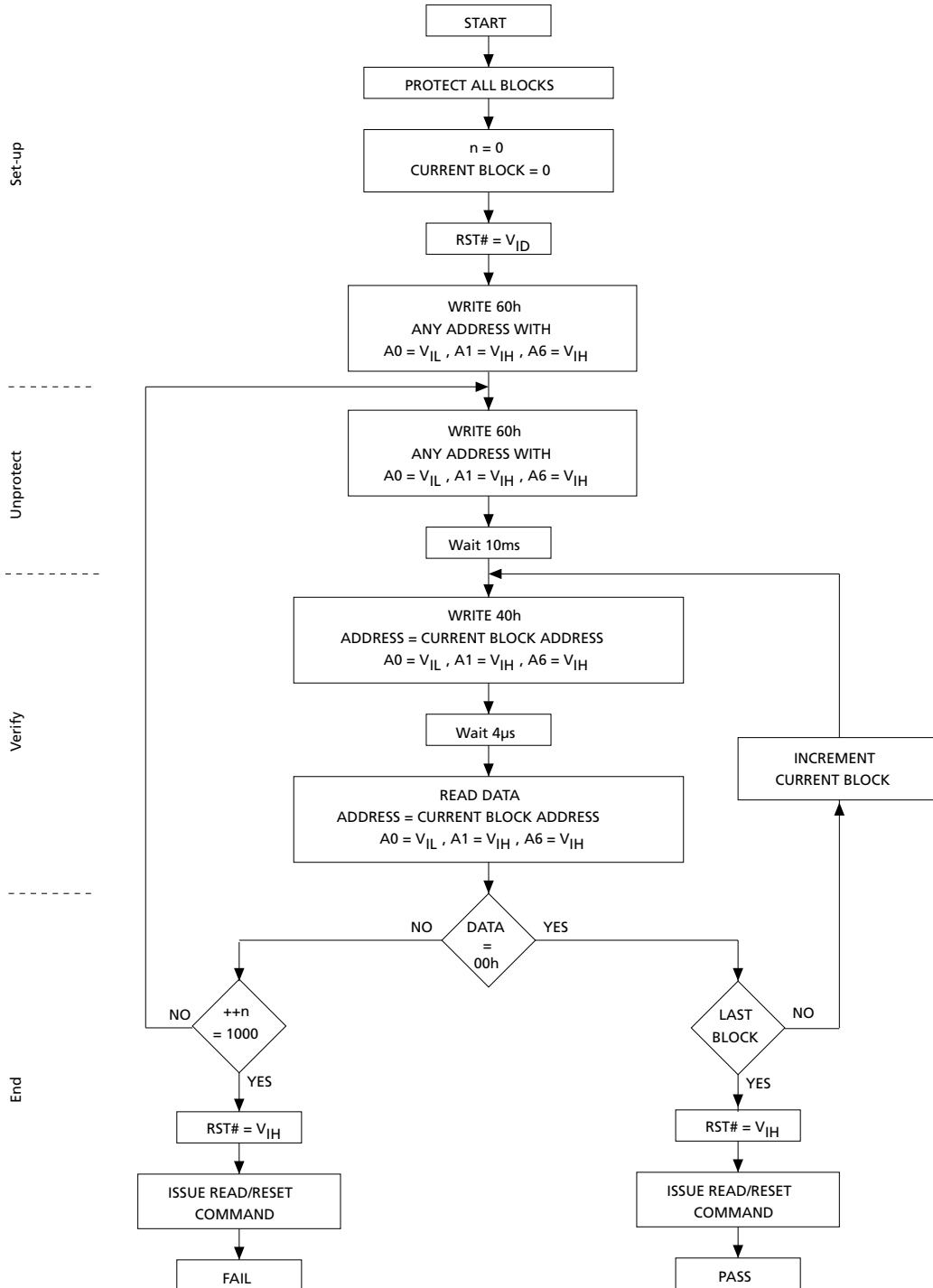

## **BYPASS Operations**

### **UNLOCK BYPASS Command**

The UNLOCK BYPASS command is used with the UNLOCK BYPASS PROGRAM command to program the memory. When device access time is slow, as with some EEPROM programmers, considerable time can be saved using BYPASS operations. Three bus WRITE operations are required to issue the UNLOCK BYPASS command.

After the UNLOCK BYPASS command is issued, the memory will accept only the UNLOCK BYPASS PROGRAM and the UNLOCK BYPASS RESET commands. The memory can be read as if in read mode.

### **UNLOCK BYPASS RESET Command**

The UNLOCK BYPASS RESET command can be used to return to read/reset mode from unlock bypass mode. Two bus WRITE operations are required to issue this command. The READ/RESET command does not exit the device from unlock bypass mode.

## **PROGRAM Operations**

### **PROGRAM Command**

The PROGRAM command can be used to program a value to one address in the memory array at a time. The command requires four bus WRITE operations; the final WRITE operation latches the address and data and starts the program/erase controller.

If the address falls in a protected block, the command is ignored, the data remains unchanged, the status register is never read, and no error condition is given.

During the PROGRAM operation, the memory ignores all commands. It is not possible to issue any command to abort or pause the operation. A READ operation during the PROGRAM operation will output the status register on the data I/O.

When the PROGRAM operation completes, the memory returns to the read mode unless an error has occurred. When an error occurs, the memory continues to output the status register. A READ/RESET command must be issued to reset the error condition and return to read mode.

**Note:** The PROGRAM command cannot change a bit set at 0 back to 1. An ERASE command must be used to set all the bits in a block or in the whole memory from 0 to 1.

### **UNLOCK BYPASS PROGRAM Command**

When the device is in unlock bypass mode, the UNLOCK BYPASS PROGRAM (A0h) command can be used to program one address in the memory array. The command requires two bus WRITE operations instead of the four required by a standard PROGRAM command; the final WRITE operation latches the address and data and starts the program/erase controller. (The standard PROGRAM command requires four bus WRITE operations.) The PROGRAM operation using the UNLOCK BYPASS PROGRAM command behaves identically to the PROGRAM operation using the PROGRAM command. The operation cannot be aborted. A bus READ operation to the memory outputs the status register.

## ERASE Operations

### CHIP ERASE Command

The CHIP ERASE command can be used to erase the entire chip. Six bus WRITE operations are required to issue the CHIP ERASE command and start the program/erase controller.

If any blocks are protected, then these are ignored, and all the other blocks are erased. If all of the blocks are protected, the CHIP ERASE operation appears to start, but will terminate within about 100 $\mu$ s, leaving the data unchanged. No error condition is given when protected blocks are ignored.

During the ERASE operation, the memory will ignore all commands. It is not possible to issue any command to abort the operation. Typical chip erase times are given in the Program/Erase Times and Program/Erase Endurance Cycles table. All bus READ operations during the CHIP ERASE operation will output the status register on the data I/O. (See the Status Register section for more details).

After the CHIP ERASE operation has completed, the memory will return to the read mode, unless an error has occurred. When an error occurs, the memory will continue to output the status register. A READ/RESET command must be issued to reset the error condition and return to read mode.

The CHIP ERASE command sets all of the bits in unprotected blocks of the memory to 1. All previous data is lost.

### BLOCK ERASE Command

The BLOCK ERASE command can be used to erase a list of one or more blocks. Six bus WRITE operations are required to select the first block in the list. Each additional block in the list can be selected by repeating the sixth bus WRITE operation using the address of the additional block. The BLOCK ERASE operation starts the program/erase controller about 50 $\mu$ s after the last bus WRITE operation. After the program/erase controller starts, it is not possible to select any more blocks. Each additional block must therefore be selected within 50 $\mu$ s of the last block. The 50 $\mu$ s timer restarts when an additional block is selected. The status register can be read after the sixth bus WRITE operation. (See the Status Register section for details on how to identify if the program/erase controller has started the BLOCK ERASE operation.)

If any selected blocks are protected, these are ignored, and all the other selected blocks are erased. If all of the selected blocks are protected, the BLOCK ERASE operation appears to start, but will terminate within about 100 $\mu$ s, leaving the data unchanged. No error condition is given when protected blocks are ignored.

During the BLOCK ERASE operation, the memory will ignore all commands except the ERASE SUSPEND command. Typical block erase times are given in the Program/Erase Times and Program/Erase Endurance Cycles table. All bus READ operations during the BLOCK ERASE operation will output the status register on the data inputs/outputs. (See the Status Register section for more details.)

After the BLOCK ERASE operation has completed, the memory will return to the read mode, unless an error has occurred. When an error occurs, the memory will continue to output the status register. A READ/RESET command must be issued to reset the error condition and return to read mode.

The BLOCK ERASE command sets all of the bits in the unprotected selected blocks to 1. All previous data in the selected blocks is lost.

### **ERASE SUSPEND Command**

The ERASE SUSPEND command may be used to temporarily suspend a BLOCK ERASE operation and return the memory to read mode. The command requires one bus WRITE operation.

The program/erase controller will suspend within the erase suspend latency time after the ERASE SUSPEND command is issued. (See the Program/Erase Times and Program/Erase Endurance Cycles table for numerical values.) After the program/erase controller has stopped, the memory will be set to read mode, and the ERASE operation will be suspended. If the ERASE SUSPEND command is issued during the period when the memory is waiting for an additional block (before the program/erase controller starts), the ERASE operation is suspended immediately and will start immediately when the ERASE RESUME command is issued. It is not possible to select any further blocks to erase after the ERASE RESUME.

During ERASE SUSPEND, it is possible to read and program cells in blocks that are not being erased; both READ and PROGRAM operations behave as normal on these blocks. If any attempt is made to program in a protected block or in the suspended block, the PROGRAM command is ignored, and the data remains unchanged. The status register is not read, and no error condition is given. Reading from blocks that are being erased will output the status register.

It is also possible to issue the AUTO SELECT and UNLOCK BYPASS commands during an ERASE SUSPEND operation. The READ/RESET command must be issued to return the device to read array mode before the RESUME command will be accepted.

### **ERASE RESUME Command**

The ERASE RESUME command must be used to restart the program/erase controller from ERASE SUSPEND. An ERASE operation can be suspended and resumed more than once.

## Status Register

Bus READ operations from any address always read the status register during PROGRAM and ERASE operations. It is also read during ERASE SUSPEND operations when an address within a block being erased is accessed. The bits in the status register are summarized in the Status Register Bits table.

### Data Polling Bit (DQ7)

The data polling bit can be used to identify whether the program/erase controller has successfully completed its operation or if it has responded to an ERASE SUSPEND operation. The data polling bit is output on DQ7 when the status register is read.

During PROGRAM operations, the data polling bit outputs the complement of the bit being programmed to DQ7. After successful completion of the PROGRAM operation, the memory returns to read mode, and bus READ operations from the address just programmed output DQ7, not its complement.

During ERASE operations, the data polling bit outputs 0, the complement of the erased state of DQ7. After successful completion of the ERASE operation, the memory returns to read mode.

In erase suspend mode, the data polling bit will output a 1 during a bus READ operation within a block being erased. The data polling bit will change from a 0 to a 1 when the program/erase controller has suspended the ERASE operation. The Data Polling Flowchart gives an example of how to use the data polling bit. A valid address is the address being programmed or an address within the block being erased.

### Toggle Bit (DQ6)

The toggle bit can be used to identify whether the program/erase controller has successfully completed its operation or if it has responded to an ERASE SUSPEND command. The toggle bit is output on DQ6 when the status register is read.

During PROGRAM and ERASE operations, the toggle bit changes from 0 to 1 to 0, etc., with successive bus READ operations at any address. After successful completion of the operation, the memory returns to read mode.

During erase suspend mode, the toggle bit will output when addressing a cell within a block being erased. The toggle bit will stop toggling when the program/erase controller has suspended the ERASE operation.

If any attempt is made to erase a protected block, the operation is aborted, no error is signaled, and DQ6 toggles for approximately 100 $\mu$ s. If any attempt is made to program a protected block or a suspended block, the operation is aborted, no error is signaled, and DQ6 toggles for approximately 1 $\mu$ s. The Data Toggle Flowchart gives an example of how to use the data toggle bit.

### Error Bit (DQ5)

The error bit can be used to identify errors detected by the program/erase controller. The error bit is set to 1 when a PROGRAM, BLOCK ERASE, or CHIP ERASE operation fails to write the correct data to the memory. If the error bit is set, a READ/RESET command must be issued before other commands are issued. The error bit is output on DQ5 when the status register is read.

Note that the PROGRAM command cannot change a bit set to 0 back to 1, and attempting to do so will set DQ5 to 1. A bus READ operation to that address will show the bit is still 0. One of the ERASE commands must be used to set all the bits in a block or in the whole memory from 0 to 1.

### Erase Timer Bit (DQ3)

The erase timer bit can be used to identify the start of program/erase controller operation during a BLOCK ERASE command. When the program/erase controller starts erasing, the erase timer bit is set to 1. Before the program/erase controller starts, the erase timer bit is set to 0, and additional blocks to be erased may be written to the command interface. The erase timer bit is output on DQ3 when the status register is read.

### Alternative Toggle Bit (DQ2)

The alternative toggle bit can be used to monitor the program/erase controller during ERASE operations. It is output on DQ2 when the status register is read.

During CHIP ERASE and BLOCK ERASE operations, the toggle bit changes from 0 to 1 to 0, etc., with successive bus READ operations from addresses within the blocks being erased. A protected block is treated the same as a block not being erased. After the operation completes, the memory returns to read mode.

During an ERASE SUSPEND operation, the alternative toggle bit changes from 0 to 1 to 0, etc., with successive bus READ operations from addresses within the blocks being erased. Bus READ operations to addresses within blocks not being erased will output the memory cell data as if in read mode.

After an ERASE operation that causes the error bit to be set, the alternative toggle bit can be used to identify which block or blocks have caused the error. The alternative toggle bit changes from 0 to 1 to 0, etc., with successive bus READ operations from addresses within blocks that have not erased correctly. The alternative toggle bit does not change if the addressed block has erased correctly.

**Table 13: Status Register Bits**

Operation	Address	DQ7	DQ6	DQ5	DQ3	DQ2	RY/BY#
PROGRAM	Any address	DQ7#	Toggle	0	–	–	0
PROGRAM DURING ERASE SUSPEND	Any address	DQ7#	Toggle	0	–	–	0
PROGRAM ERROR	Any address	DQ7#	Toggle	1	–	–	0
CHIP ERASE	Any address	0	Toggle	0	1	Toggle	0
BLOCK ERASE BEFORE TIMEOUT	Erasing block	0	Toggle	0	0	Toggle	0
	Non-erasing block	0	Toggle	0	0	No Toggle	0
BLOCK ERASE	Erasing block	0	Toggle	0	1	Toggle	0
	Non-erasing block	0	Toggle	0	1	No Toggle	0
ERASE SUSPEND	Erasing block	1	No Toggle	0	–	Toggle	1
	Non-erasing block	Data read as normal					

**Table 13: Status Register Bits (Continued)**

Operation	Address	DQ7	DQ6	DQ5	DQ3	DQ2	RY/BY#
ERASE ERROR	Good block address	0	Toggle	1	1	No Toggle	0
	Faulty block address	0	Toggle	1	1	Toggle	0

Note: 1. Unspecified data bits should be ignored.

**Figure 9: Data Polling Flowchart**

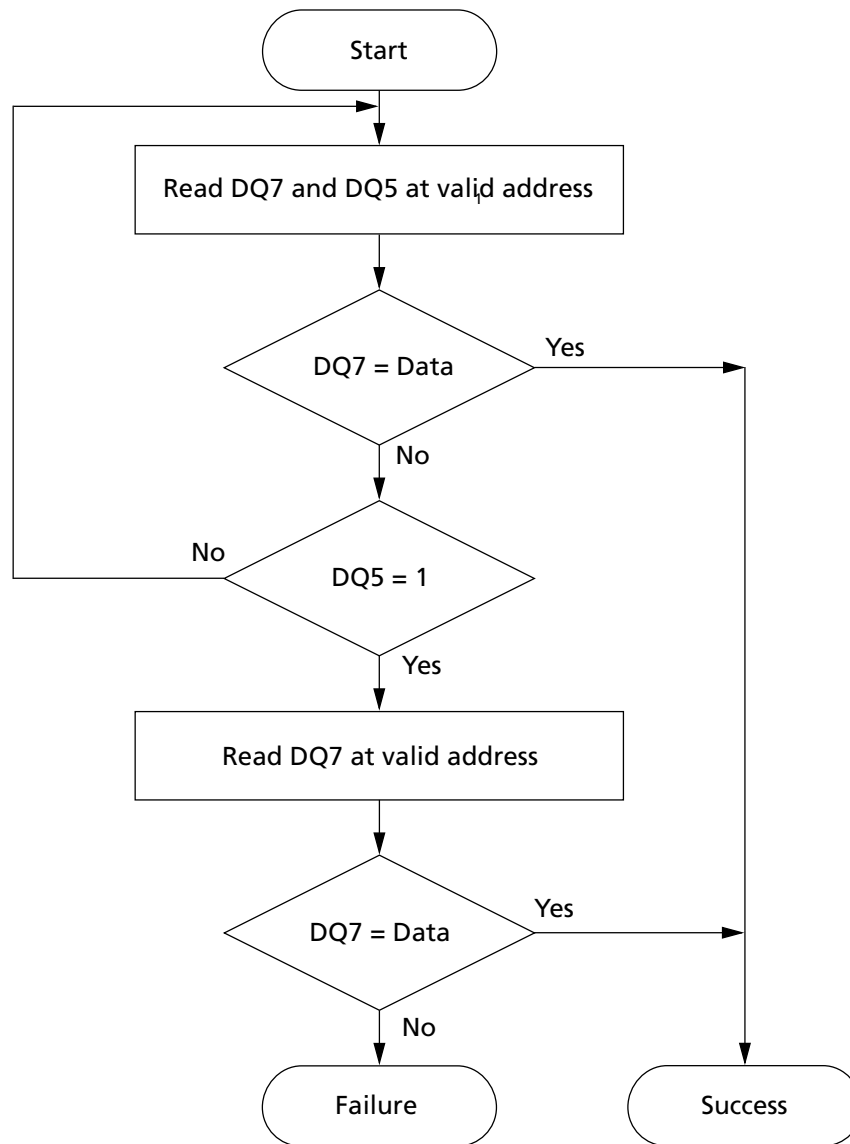
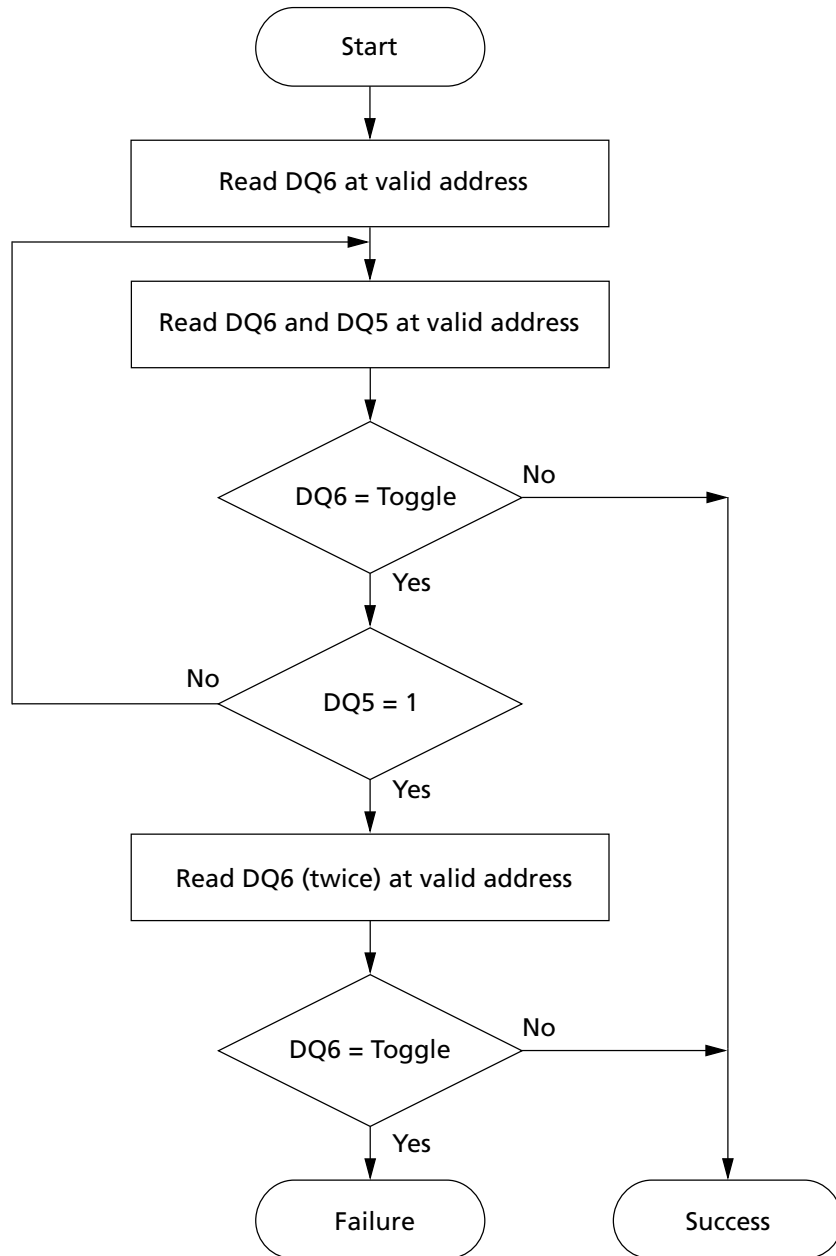

Figure 10: Data Toggle Flowchart



## Absolute Ratings and Operating Conditions

Stresses greater than those listed may cause permanent damage to the device. This is a stress rating only, and functional operation of the device at these or any other conditions outside those indicated in the operational sections of this specification is not implied. Exposure to absolute maximum rating conditions for extended periods may adversely affect reliability.

**Table 14: Absolute Maximum/Minimum Ratings**

Parameter	Symbol	Min	Max	Unit	Notes
Temperature under bias	$T_{BIAS}$	-50	125	°C	
Storage temperature	$T_{STG}$	-65	150	°C	
Input/output voltage	$V_{IO}$	-0.6	$V_{CC} + 0.6$	V	1, 2
Supply voltage	$V_{CC}$	-0.6	4	V	
Identification voltage	$V_{ID}$	-0.6	13.5	V	

- Notes:
1. During signal transitions, minimum voltage may undershoot to  $-2V$  for periods less than 20ns.
  2. During signal transitions, maximum voltage may overshoot to  $V_{CC} + 2V$  for periods less than 20ns.

**Table 15: Operating Conditions**

Parameter	Symbol	M29W160ET/B								Unit
		70ns		7Ans		80ns <sup>1</sup>		90ns		
		Min	Max	Min	Max	Min	Max	Min	Max	
Supply voltage	$V_{CC}$	2.7	3.6	2.7	3.6	2.5	3.6	2.7	3.6	V
Ambient operating temperature (device grade 6)	$T_A$	-40	85/125 <sup>2</sup>	-40	85	-40	125	-40	85	°C
Load capacitance	$C_L$	30		30		30		30		pF
Input rise and fall times	-	-	10	-	10	-	10	-	10	ns
Input pulse voltages	-	0 to $V_{CC}$		0 to $V_{CC}$		0 to $V_{CC}$		0 to $V_{CC}$		V
Input and output timing reference voltages	-	$V_{CC}/2$		$V_{CC}/2$		$V_{CC}/2$		$V_{CC}/2$		V

- Notes:
1. 80ns option supported only on  $-40^{\circ}\text{C}$  to  $125^{\circ}\text{C}$  devices.
  2.  $85^{\circ}\text{C}$  = Industrial part;  $125^{\circ}\text{C}$  = Automotive grade part.

**Figure 11: AC Measurement Load Circuit**

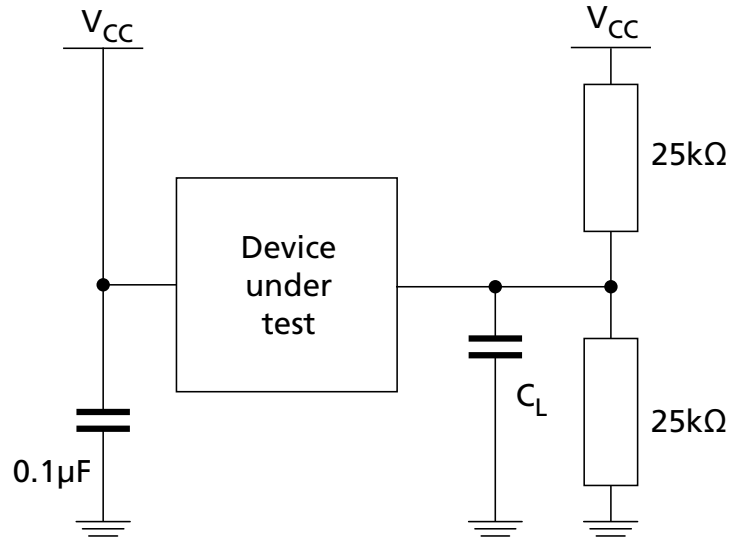

Note: 1.  $C_L$  includes jig capacitance.

**Figure 12: AC Measurement I/O Waveform**

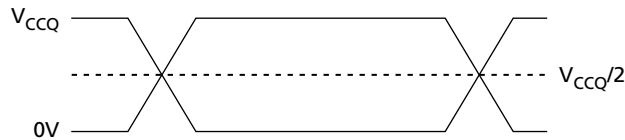

**Table 16: Input/Output Capacitance**

Parameter	Symbol	Test Condition	Min	Max	Unit
Input capacitance	$C_{IN}$	$V_{IN} = 0V$	–	6	pF
Output capacitance	$C_{OUT}$	$V_{OUT} = 0V$	–	12	pF

Note: 1. Sampled only, not 100% tested.

## DC Characteristics

**Table 17: DC Current Characteristics**

Parameter	Symbol	Conditions	Typ	Max	Unit	Notes
Input leakage current	$I_{LI}$	$0V \leq V_{IN} \leq V_{CC}$	–	$\pm 1$	$\mu A$	
Output leakage current	$I_{LO}$	$0V \leq V_{OUT} \leq V_{CC}$	–	$\pm 1$	$\mu A$	
Supply read current	$I_{CC1}$	$CE\# = V_{IL}$ , $OE\# = V_{IH}$ , $f = 6 \text{ MHz}$	4.5	10	mA	
Supply standby current	$I_{CC2}$	$CE\# = V_{CC} \pm 0.2V$ $RP\# = V_{CC} \pm 0.2V$	35	100	$\mu A$	1
Supply program/erase current	$I_{CC3}$	Program/erase controller active	–	20	mA	2
Identification current	$I_{ID}$	$A9 = V_{ID}$	–	100	$\mu A$	

- Notes: 1. When the bus is inactive for 150ns or more, the memory enters automatic standby.  
2. Sampled only; not 100% tested.

**Table 18: DC Voltage Characteristics**

Parameter	Symbol	Conditions	Min	Max	Unit
Input LOW voltage	$V_{IL}$	–	–0.5	0.8	V
Input HIGH voltage	$V_{IH}$	–	$0.7 V_{CC}$	$V_{CC} + 0.3$	V
Output LOW voltage	$V_{OL}$	$I_{OL} = 1.8\text{mA}$	–	0.45	V
Output HIGH voltage	$V_{OH}$	$I_{OH} = -100\mu A$	$V_{CC} - 0.4$	–	V
Identification voltage	$V_{ID}$	–	11.5	12.5	V
Program/erase lockout supply voltage	$V_{LKO}$	–	1.8	2.3	V

## Read AC Characteristics

**Table 19: Read AC Characteristics**

Parameter	Symbol		Condition	7A/70/80 <sup>1</sup>		90		Unit	Notes
	Legacy	JEDEC		Min	Max	Min	Max		
Address valid to next address valid	<sup>t</sup> RC	<sup>t</sup> AVAV	CE# = V <sub>IL</sub> , OE# = V <sub>IL</sub>	70	–	90	–	ns	
Address valid to output valid	<sup>t</sup> ACC	<sup>t</sup> AVQV	CE# = V <sub>IL</sub> , OE# = V <sub>IL</sub>	–	70	–	90	ns	
CE# LOW to output transition	<sup>t</sup> LZ	<sup>t</sup> ELQX	OE# = V <sub>IL</sub>	0	–	0	–	ns	2
CE# LOW to output valid	<sup>t</sup> E	<sup>t</sup> ELQV	OE# = V <sub>IL</sub>	–	70	–	90	ns	
OE# LOW to output transition	<sup>t</sup> OLZ	<sup>t</sup> GLQX	CE# = V <sub>IL</sub>	0	–	0	–	ns	2
OE# LOW to output valid	<sup>t</sup> OE	<sup>t</sup> GLQV	CE# = V <sub>IL</sub>	–	25	–	35	ns	
CE# HIGH to output High-Z	<sup>t</sup> HZ	<sup>t</sup> EHQZ	OE# = V <sub>IL</sub>	–	25	–	30	ns	2
OE# HIGH to output High-Z	<sup>t</sup> DF	<sup>t</sup> GHQZ	CE# = V <sub>IL</sub>	–	25	–	30	ns	2
CE#, OE#, or address transition to output transition	<sup>t</sup> OH	<sup>t</sup> EHQX, <sup>t</sup> GHQX, <sup>t</sup> AXQX	–	0	–	0	–	ns	
CE# to BYTE# LOW	<sup>t</sup> ELFL	<sup>t</sup> ELBL	–	–	5	–	5	ns	
CE# to BYTE# HIGH	<sup>t</sup> ELFH	<sup>t</sup> ELBH	–	–	5	–	5	ns	
BYTE# LOW to output High-Z	<sup>t</sup> FLQZ	<sup>t</sup> BLQZ	–	–	25	–	30	ns	
BYTE# HIGH to output valid	<sup>t</sup> FHQV	<sup>t</sup> BHQV	–	–	30	–	40	ns	

- Notes: 1. 70ns becomes 80ns if the 80ns device code is used.  
2. Sampled only; not 100% tested.

Figure 13: Random AC Timing

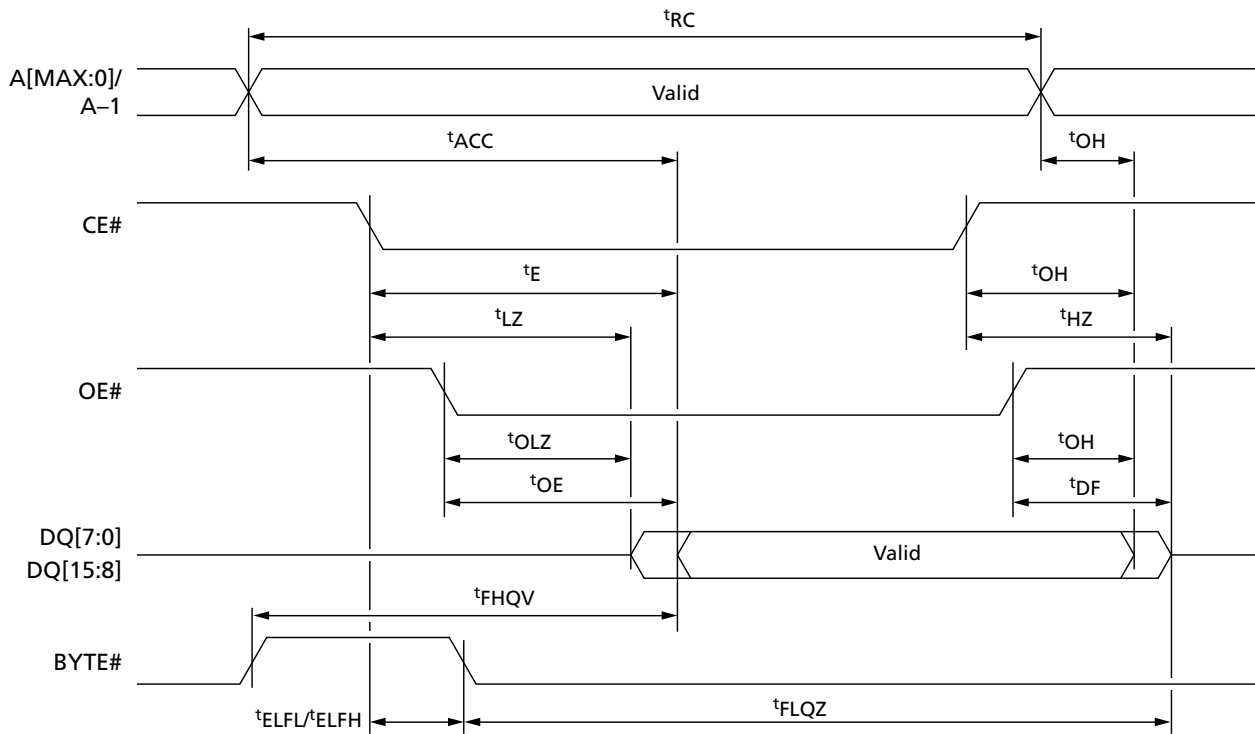

## Write AC Characteristics

**Table 20: WE#-Controlled Write AC Characteristics**

Parameter	Symbol		7A/70/80 <sup>1</sup>		90		Unit	Notes
	Legacy	JEDEC	Min	Max	Min	Max		
Address valid to next address valid	t <sup>WC</sup>	t <sup>AVAV</sup>	70	–	90	–	ns	
CE# LOW to WE# LOW	t <sup>CS</sup>	t <sup>ELWL</sup>	0	–	0	–	ns	
WE# LOW to WE# HIGH	t <sup>WP</sup>	t <sup>WLWH</sup>	45	–	50	–	ns	
Input valid to WE# HIGH	t <sup>DS</sup>	t <sup>DVWH</sup>	45	–	50	–	ns	2
WE# HIGH to input transition	t <sup>DH</sup>	t <sup>WHDX</sup>	0	–	0	–	ns	
WE# HIGH to CE# HIGH	t <sup>CH</sup>	t <sup>WHEH</sup>	0	–	0	–	ns	
WE# HIGH to WE# LOW	t <sup>WPH</sup>	t <sup>WHWL</sup>	30	–	30	–	ns	
Address valid to WE# LOW	t <sup>AS</sup>	t <sup>AVWL</sup>	0	–	0	–	ns	
WE# LOW to address transition	t <sup>AH</sup>	t <sup>WLAX</sup>	45	–	50	–	ns	
OE# HIGH to WE# LOW	–	t <sup>GHWL</sup>	0	–	0	–	ns	
WE# HIGH to OE# LOW	t <sup>OEH</sup>	t <sup>WHGL</sup>	0	–	0	–	ns	
Program/erase valid to RY/BY# LOW	t <sup>BUSY</sup>	t <sup>WHRL</sup>	–	30	–	35	ns	2
V <sub>CC</sub> HIGH to CE# LOW	t <sup>VCS</sup>	t <sup>VCHEL</sup>	50	–	50	–	μs	

- Notes: 1. 70ns becomes 80ns if the 80ns device code is used.  
2. Sampled only; not 100% tested.

**Figure 14: WE#-Controlled AC Timing**

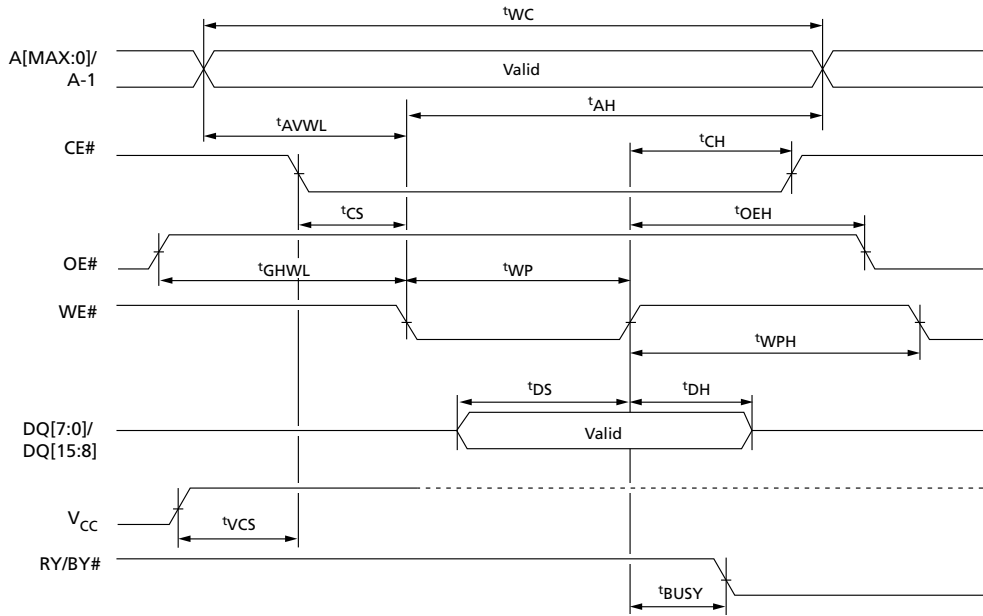
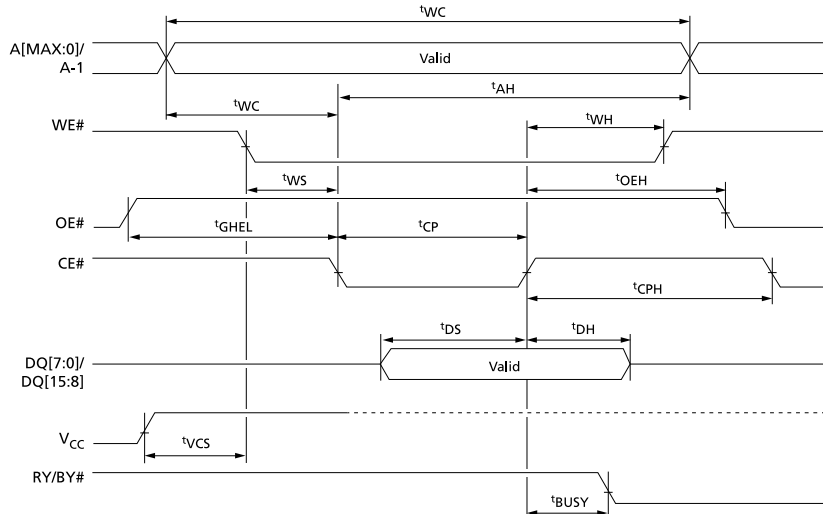

**Table 21: CE#-Controlled Write AC Characteristics**

Parameter	Symbol		7A/70/80 <sup>2</sup>		90		Unit
	Legacy	JEDEC	Min	Max	Min	Max	
Address valid to next address valid	t <sup>WC</sup>	t <sup>AVAV</sup>	70	–	90	–	ns
WE# LOW to CE# LOW	t <sup>WS</sup>	t <sup>WLEL</sup>	0	–	0	–	ns
CE# LOW to CE# HIGH	t <sup>CP</sup>	t <sup>ELEH</sup>	45	–	50	–	ns
Input valid to CE# HIGH	t <sup>DS</sup>	t <sup>DVEH</sup>	45	–	50	–	ns
CE# HIGH to input transition	t <sup>DH</sup>	t <sup>EHD<sub>X</sub></sup>	0	–	0	–	ns
CE# HIGH to WE# HIGH	t <sup>WH</sup>	t <sup>EHWH</sup>	0	–	0	–	ns
CE# HIGH to CE# LOW	t <sup>CPH</sup>	t <sup>EHEL</sup>	30	–	30	–	ns
Address valid to CE# LOW	t <sup>AS</sup>	t <sup>AVEL</sup>	0	–	0	–	ns
CE# LOW to address transition	t <sup>AH</sup>	t <sup>ELAX</sup>	45	–	50	–	ns
OE# HIGH to CE# LOW	–	t <sup>GHEL</sup>	0	–	0	–	ns
CE# HIGH to OE# LOW	t <sup>OE<sub>H</sub></sup>	t <sup>EHGL</sup>	0	–	0	–	ns
Program/Erase valid to RY/BY# LOW	t <sup>BUSY</sup>	t <sup>EHRL</sup>	–	30	–	35	ns
V <sub>CC</sub> HIGH to WE# LOW	t <sup>VCS</sup>	t <sup>VCHWL</sup>	50	–	50	–	μs

- Notes: 1. 70ns becomes 80ns if the 80ns device code is used.  
2. Sampled only; not 100% tested.

**Figure 15: CE#-Controlled AC Timing**



## Program/Erase Characteristics

**Table 22: Program/Erase Times and Endurance Cycles**

Notes 1 and 2 apply to the entire table

Parameter	Min	Typ	Max	Unit	Notes
Chip erase	–	29	60	s	3
Block erase (64KB)	–	0.8	1.6	s	4
Erase suspend latency time	–	20	25	μs	4
Program (byte or word)	–	13	200	μs	3
Chip program (byte by byte)	–	26	120	s	3
Chip program (word by word)	–	13	60	s	3
PROGRAM/ERASE cycles (per block)	100,000	–	–	cycles	
Data retention	20	–	–	years	

- Notes:
1. Typical values measured at room temperature and nominal voltages and for not cycled devices.
  2. Sampled, but not 100% tested.
  3. Maximum value measured at worst case conditions for both temperature and  $V_{CC}$  after 100,000 PROGRAM/ERASE cycles.
  4. Maximum value measured at worst case conditions for both temperature and  $V_{CC}$ .

## Reset Characteristics

Table 23: Reset/Block Temporary Unprotect AC Characteristics

Condition/Parameter		Symbol		M29W160ET/B		Unit	Notes
		Legacy	JEDEC	7A/70/80	90		
RST# HIGH to WE# LOW; CE# LOW; OE# LOW	Min	$t_{RH}$	$t_{PHWL}$ $t_{PHEL}$ $t_{PHGL}$	50	50	ns	1
RY/BY# HIGH to WE# LOW; CE# LOW; OE# LOW	Min	$t_{RB}$	$t_{RHWL}$ $t_{RHEL}$ $t_{RHGL}$	0	0	ns	1
RST# pulse width	Min	$t_{RP}$	$t_{PLPX}$	500	500	ns	
RST# LOW to read mode	Max	$t_{READY}$	$t_{PLYH}$	10	10	$\mu s$	1
RST# rise time to $V_{ID}$	Min	$t_{VIDR}$	$t_{PHPHH}$	500	500	ns	1

Note: 1. Sampled only; not 100% tested.

Figure 16: Reset/Block Temporary Unprotect AC Waveforms

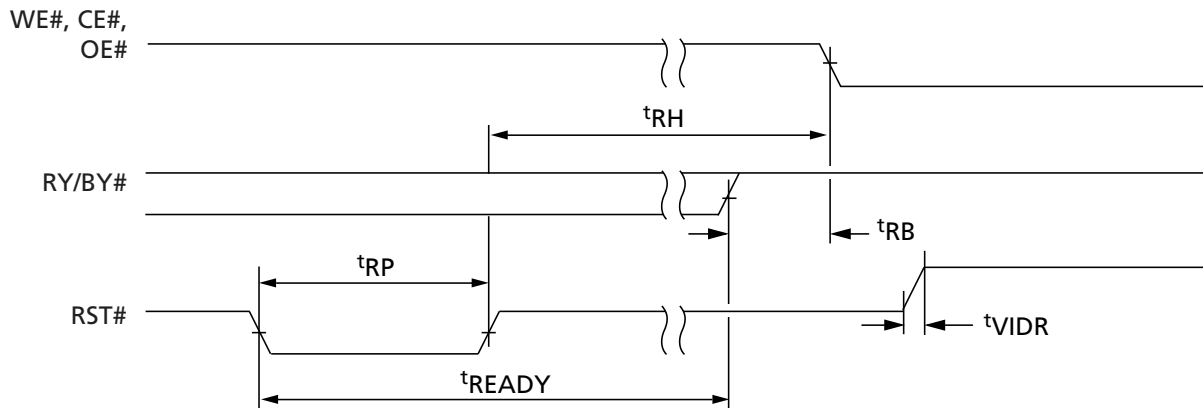

## Package Dimensions

Figure 17: 48-Pin TSOP – 12mm x 20mm

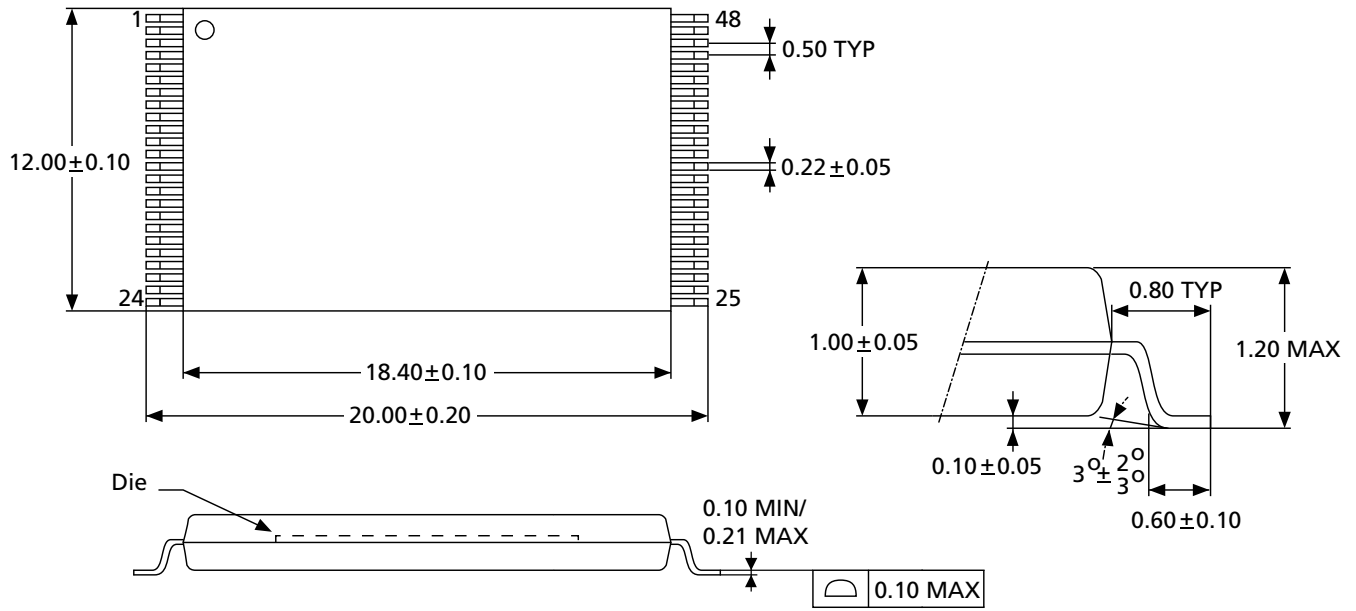

Note: 1. All dimensions are in millimeters.

**Figure 18: 48-Ball TFBGA – 6mm x 8mm**

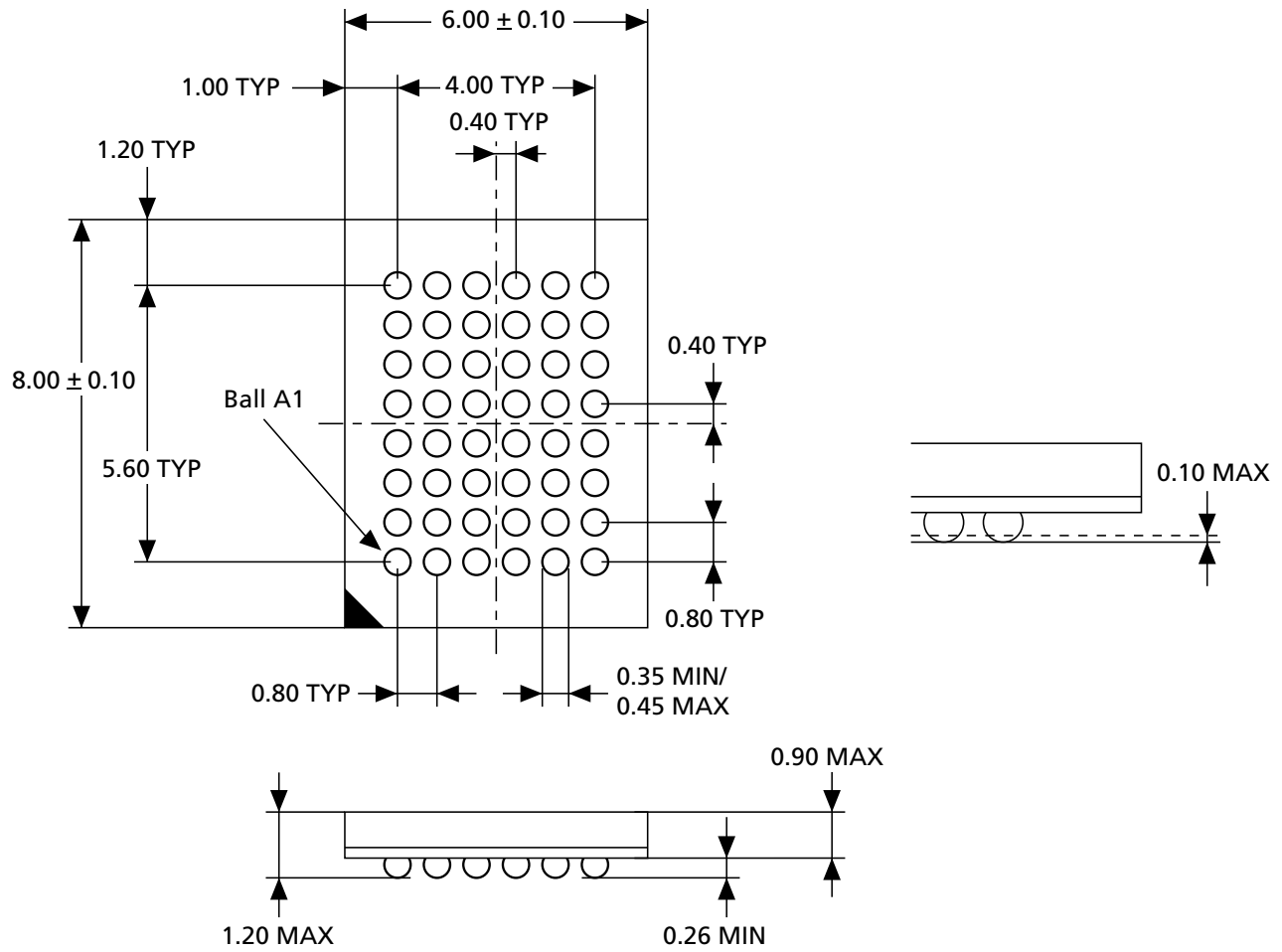

Note: 1. All dimensions are in millimeters.

**Figure 19: 64-Ball FBGA – 11mm x 13mm**

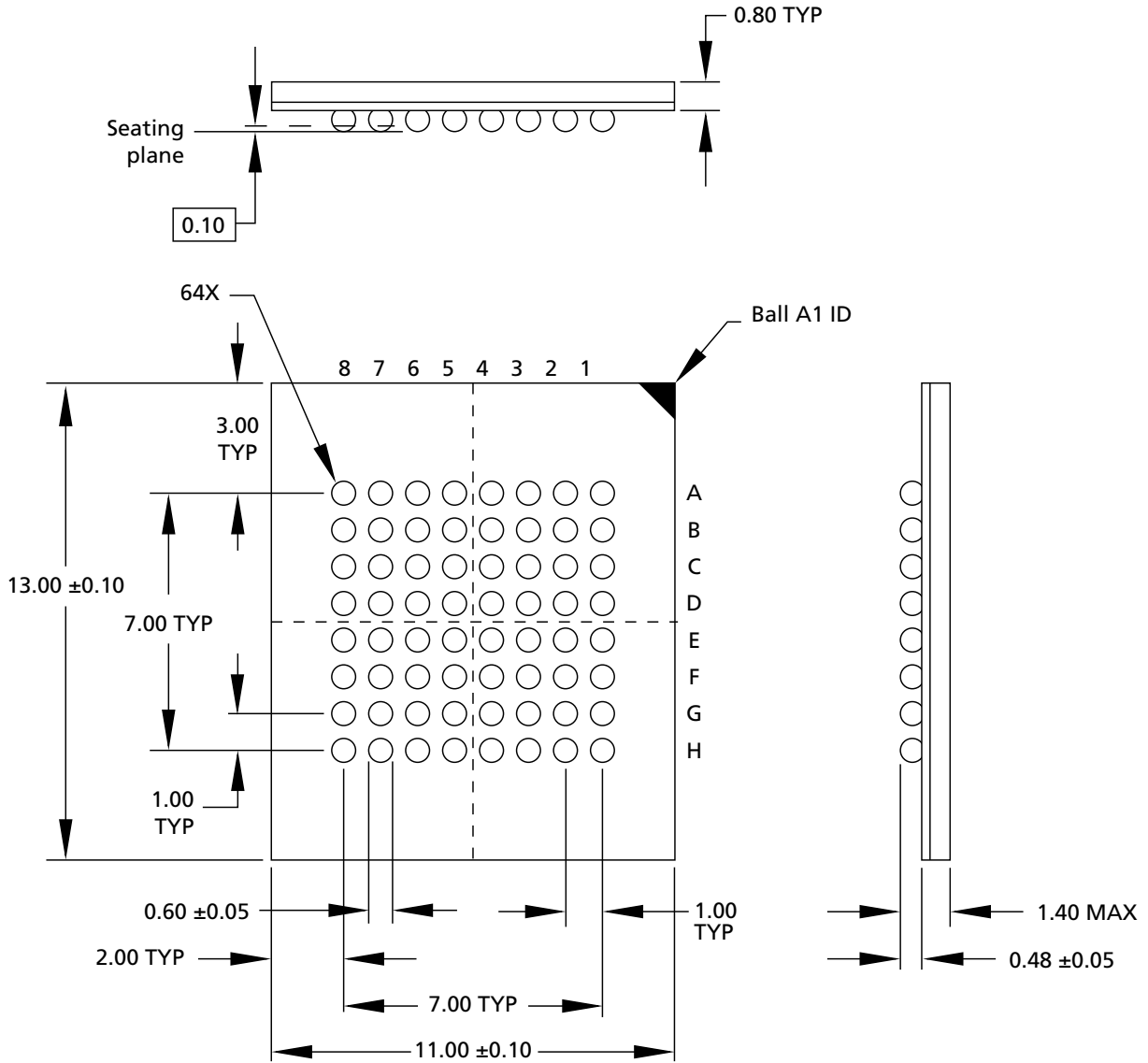

Note: 1. All dimensions are in millimeters.

## Revision History

### Rev. C – 2/18

- Added Important Notes and Warnings section for further clarification aligning to industry standards

### Rev. B – 06/13

- Updates to format, typo fixes

### Rev. A – 07/12

- Initial Micron brand release

8000 S. Federal Way, P.O. Box 6, Boise, ID 83707-0006, Tel: 208-368-4000  
[www.micron.com/products/support](http://www.micron.com/products/support) Sales inquiries: 800-932-4992  
Micron and the Micron logo are trademarks of Micron Technology, Inc.  
All other trademarks are the property of their respective owners.

This data sheet contains minimum and maximum limits specified over the power supply and temperature range set forth herein. Although considered final, these specifications are subject to change, as further product development and data characterization sometimes occur.

## Looking for pricing, stock, or lifecycle information?

Click below to explore more details on WIN SOURCE:

- ⊖ [View M29W160EB70N6F TR on WIN SOURCE](#)
- ⊖ [Micron Technology Inc. Information](#)

## Optimize Your Supply Chain with WIN SOURCE Solutions

- ✓ Global Sourcing Solution
- ✓ Obsolete Management
- ✓ Cost Control Management
- ✓ Shortage Management
- ✓ Alternative Solution
- ✓ Excess Inventory Management