



**THE DATASHEET OF  
ATS177-PG-A-B**



**Description**

ATS177 is an integrated Hall-Effect latch sensor designed for electronic commutation of brush-less DC motor applications. The device includes an on-chip Hall voltage generator for magnetic sensing, a comparator that amplifies the Hall voltage, and a schmitt trigger to provide switching hysteresis for noise rejection, and open-collector output. An internal bandgap regulator provides a temperature compensated supply voltage for internal circuits and allows a wide operating supply range.

When the magnetic flux density (**B**) is larger than operate point (**Bop**), output is switched on (DO pin is pulled low). The output state is held on until a magnetic flux density reversal falls below Brp. When **B** is less than Brp, the output is switched off.

The ATS177 is available in SIP-3L package.

**Features**

- Bipolar Hall-Effect latch sensor
- 3.5V to 20V DC operating voltage
- Temperature compensation
- Open-collector pre-driver
- 25mA maximum output sink current
- Built-in reverse polarity protection
- Operating temperature: -40°C to +125°C
- SIP-3L package
- Green Molding Compound (No Br, Sb) (Note 1)

Notes: 1. EU Directive 2002/95/EC (RoHS). All applicable RoHS exemptions applied. Please visit our website at [http://www.diodes.com/products/lead\\_free.html](http://www.diodes.com/products/lead_free.html).

**Pin Assignments**

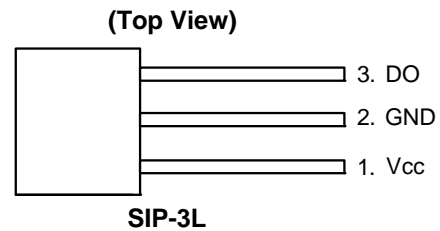

**Applications**

- Brush-less DC Motor
- Brush-less DC Fan
- Revolution counting
- Speed measurement

**Typical Application Circuit**

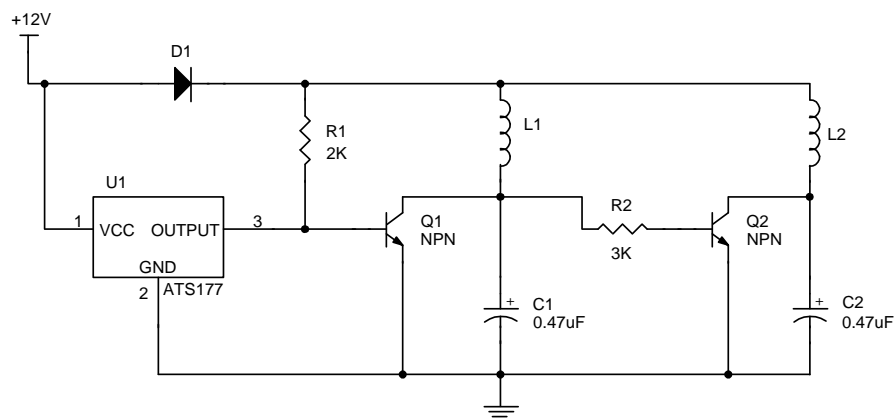

**Brush-less DC Fan**

### Pin Descriptions

Pin name	P/I/O	Pin #	Description
V <sub>CC</sub>	P	1	Positive power supply
GND	P	2	Ground
DO	O	3	Digital output

### Functional Block Diagram

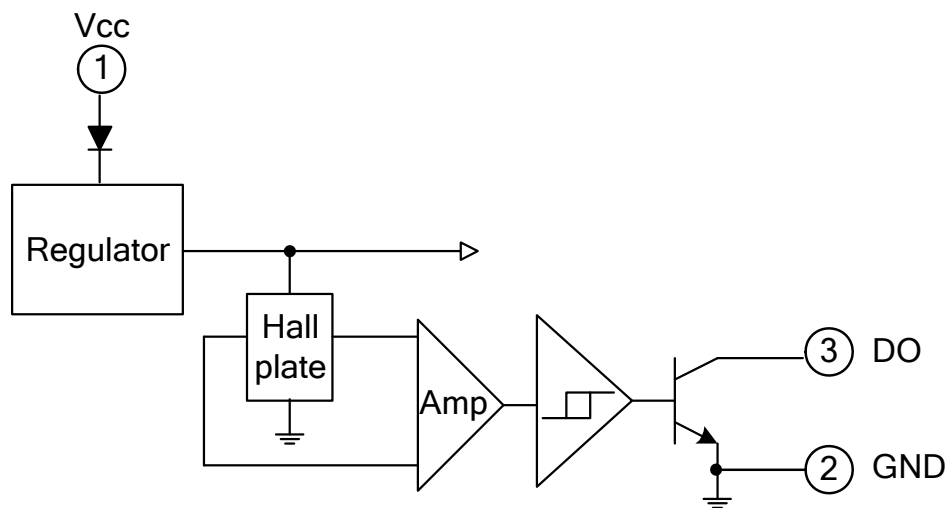

### Absolute Maximum Ratings (T<sub>A</sub> = 25°C)

Symbol	Characteristics		Rating	Unit
V <sub>CC</sub>	Supply Voltage		20	V
V <sub>RCC</sub>	Reverse V <sub>CC</sub> Polarity Voltage		-20	V
B	Magnetic Flux Density		Unlimited	
V <sub>CE</sub>	Output OFF Voltage		30	V
P <sub>D</sub>	Package Power Dissipation	SIP-3L	550	mW
I <sub>C</sub>	Output "ON" Current	Continuous	25	mA
T <sub>J(MAX)</sub>	Maximum Junction Temperature		150	°C
T <sub>S</sub>	Storage Temperature Range		-65~+150	°C

### Recommended Operating Conditions

Symbol	Characteristic	Conditions	Min	Max	Unit
V <sub>CC</sub>	Supply Voltage	Operating	3.5	20	V
T <sub>A</sub>	Operating Ambient Temperature (Note 2)	Operating	-20	85	°C

Notes: 2. Shall not exceed P<sub>D</sub> and Safety Operation Area.

**Electrical Characteristics (T<sub>A</sub> = 25°C)**

Symbol	Characteristic	Test Conditions	Min	Typ.	Max	Unit
V <sub>CE (sat)</sub>	Output Saturation Voltage	V <sub>CC</sub> = 14V, I <sub>c</sub> = 20mA	-	300	700	mV
I <sub>cex</sub>	Output Leakage Current	V <sub>CE</sub> = 14V, V <sub>CC</sub> = 14V	-	<0.1	10	uA
I <sub>cc</sub>	Supply Current	V <sub>CC</sub> = 20V, Output Open	-	5	10	mA
t <sub>r</sub>	Output Rise Time	V <sub>CC</sub> = 14V, R <sub>L</sub> = 820Ω, C <sub>L</sub> = 20pF	-	0.3	1.5	us
t <sub>f</sub>	Output Falling Time	V <sub>CC</sub> = 14V, R <sub>L</sub> = 820Ω, C <sub>L</sub> = 20pF	-	0.3	1.5	us

**Test Circuit**

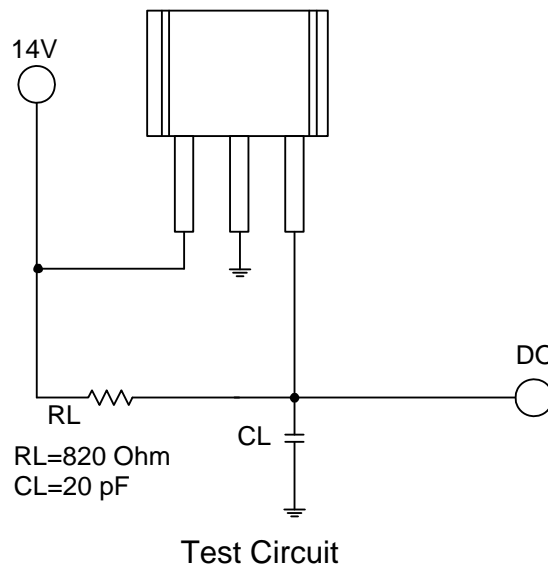

**Magnetic Characteristics (T<sub>A</sub> = 25°C, Note 3)**

(1mT=10 Gauss)

**A grade**

Symbol	Parameter	Min	Typ.	Max	Unit
Bops(south pole to brand side)	Operation Point	5	-	70	Gauss
Brps(south pole to brand side)	Release Point	-70	-	-5	Gauss
Bhy( Bopx - Brpx )	Hysteresis	-	80	-	Gauss

**B grade**

Symbol	Parameter	Min	Typ.	Max	Unit
Bops(south pole to brand side)	Operation Point	-	-	100	Gauss
Brps(south pole to brand side)	Release Point	-100	-	-	Gauss
Bhy( Bopx - Brpx )	Hysteresis	-	80	-	Gauss

Notes: 3. Magnetic characteristics may vary with supply voltage, operating temperature and after soldering.

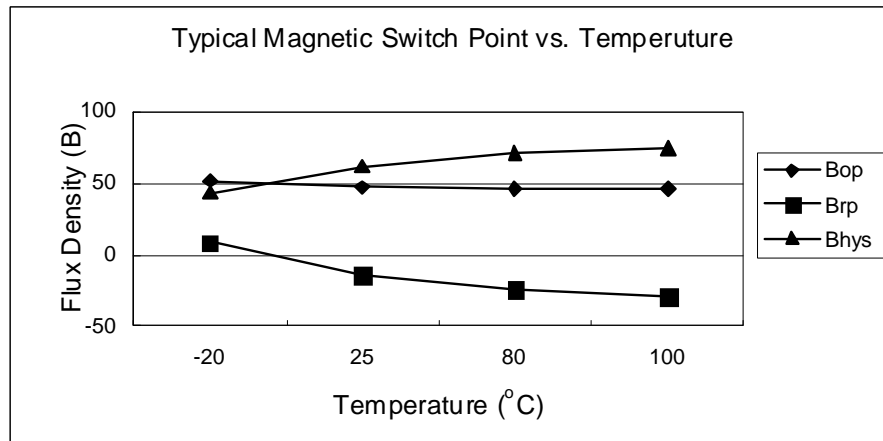
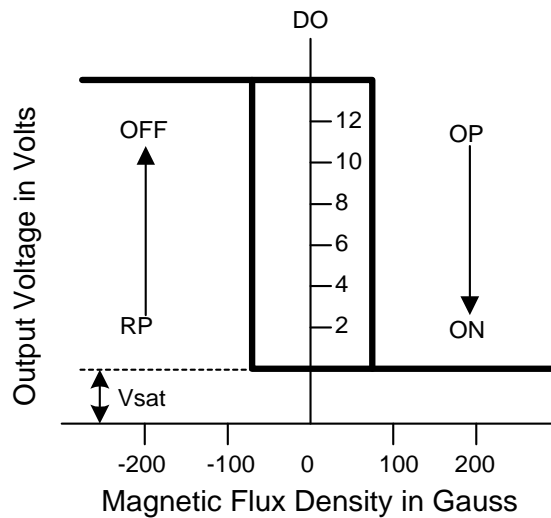

**Performance Characteristics**

**(1) SIP-3L**

<b>T<sub>A</sub> (°C)</b>	<b>25</b>	<b>50</b>	<b>60</b>	<b>70</b>	<b>80</b>	<b>85</b>	<b>90</b>	<b>95</b>	<b>100</b>
P <sub>D</sub> (mW)	550	440	396	352	308	286	264	242	220
<b>T<sub>A</sub> (°C)</b>	<b>105</b>	<b>110</b>	<b>115</b>	<b>120</b>	<b>125</b>	<b>130</b>	<b>135</b>	<b>140</b>	<b>150</b>
P <sub>D</sub> (mW)	198	176	154	132	110	88	66	44	0

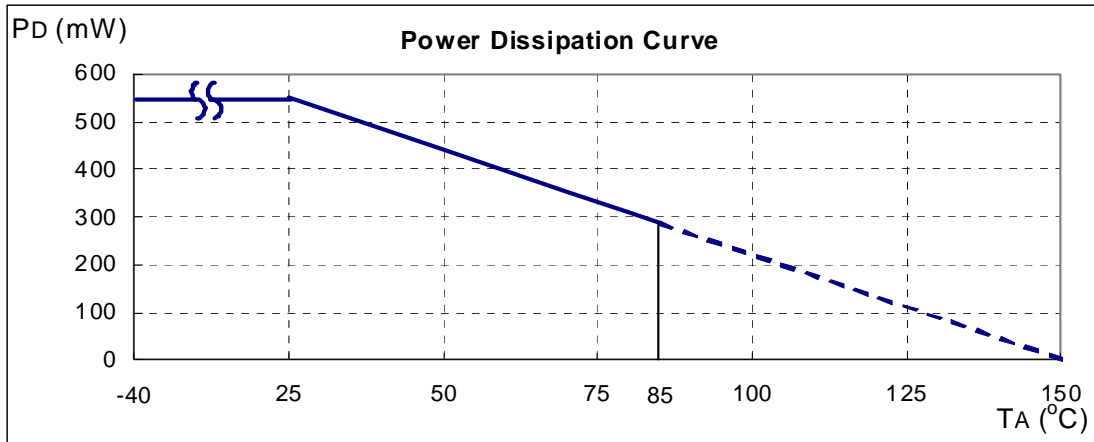





**Package Outline Dimensions (Continued)**

**(2) Package Type: SIP-3L for Ammo pack**

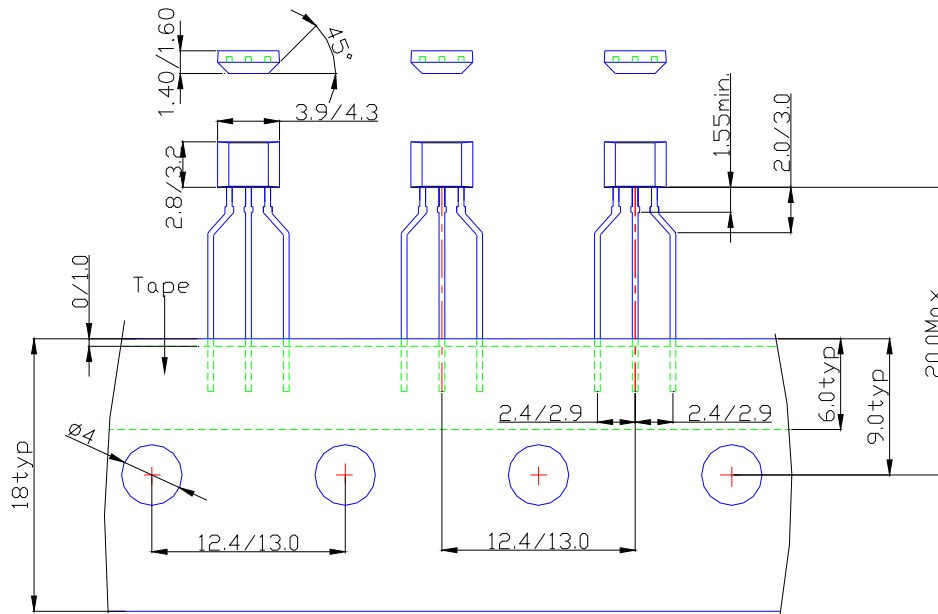

**IMPORTANT NOTICE**

DIODES INCORPORATED MAKES NO WARRANTY OF ANY KIND, EXPRESS OR IMPLIED, WITH REGARDS TO THIS DOCUMENT, INCLUDING, BUT NOT LIMITED TO, THE IMPLIED WARRANTIES OF MERCHANTABILITY AND FITNESS FOR A PARTICULAR PURPOSE (AND THEIR EQUIVALENTS UNDER THE LAWS OF ANY JURISDICTION).

Diodes Incorporated and its subsidiaries reserve the right to make modifications, enhancements, improvements, corrections or other changes without further notice to this document and any product described herein. Diodes Incorporated does not assume any liability arising out of the application or use of this document or any product described herein; neither does Diodes Incorporated convey any license under its patent or trademark rights, nor the rights of others. Any Customer or user of this document or products described herein in such applications shall assume all risks of such use and will agree to hold Diodes Incorporated and all the companies whose products are represented on Diodes Incorporated website, harmless against all damages.

Diodes Incorporated does not warrant or accept any liability whatsoever in respect of any products purchased through unauthorized sales channel.

Should Customers purchase or use Diodes Incorporated products for any unintended or unauthorized application, Customers shall indemnify and hold Diodes Incorporated and its representatives harmless against all claims, damages, expenses, and attorney fees arising out of, directly or indirectly, any claim of personal injury or death associated with such unintended or unauthorized application.

Products described herein may be covered by one or more United States, international or foreign patents pending. Product names and markings noted herein may also be covered by one or more United States, international or foreign trademarks.

**LIFE SUPPORT**

Diodes Incorporated products are specifically not authorized for use as critical components in life support devices or systems without the express written approval of the Chief Executive Officer of Diodes Incorporated. As used herein:

A. Life support devices or systems are devices or systems which:

1. are intended to implant into the body, or
2. support or sustain life and whose failure to perform when properly used in accordance with instructions for use provided in the labeling can be reasonably expected to result in significant injury to the user.

B. A critical component is any component in a life support device or system whose failure to perform can be reasonably expected to cause the failure of the life support device or to affect its safety or effectiveness.

Customers represent that they have all necessary expertise in the safety and regulatory ramifications of their life support devices or systems, and acknowledge and agree that they are solely responsible for all legal, regulatory and safety-related requirements concerning their products and any use of Diodes Incorporated products in such safety-critical, life support devices or systems, notwithstanding any devices- or systems-related information or support that may be provided by Diodes Incorporated. Further, Customers must fully indemnify Diodes Incorporated and its representatives against any damages arising out of the use of Diodes Incorporated products in such safety-critical, life support devices or systems.

Copyright © 2010, Diodes Incorporated

[www.diodes.com](http://www.diodes.com)

## Looking for pricing, stock, or lifecycle information?

Click below to explore more details on WIN SOURCE:

 [View \*\*ATS177-PG-A-B\*\* on WIN SOURCE](#)

 [Diodes Incorporated](#) Information

## Optimize Your Supply Chain with WIN SOURCE Solutions

-  Global Sourcing Solution
-  Obsolete Management
-  Cost Control Management
-  Shortage Management
-  Alternative Solution
-  Excess Inventory Management