



**THE DATASHEET OF  
IKU04N60RBKMA1**



## IGBT

IGBT with integrated diode in packages offering space saving advantage

### IKD04N60R, IKU04N60R

600V TRENCHSTOP™ RC-Series for hard switching applications

Datasheet

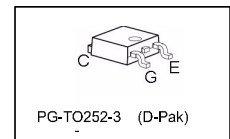
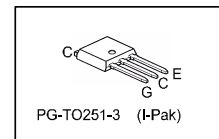
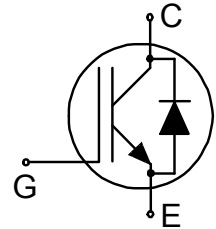
Industrial & Multimarket

### IGBT with integrated diode in packages offering space saving advantage

#### Features:

TRENCHSTOP™ Reverse Conducting (RC) technology for 600V applications offering

- Optimised  $V_{CEsat}$  and  $V_F$  for low conduction losses
- Smooth switching performance leading to low EMI levels
- Very tight parameter distribution
- Operating range of 1 to 20kHz
- Maximum junction temperature 175°C
- Short circuit capability of 5μs
- Best in class current versus package size performance
- Qualified according to JEDEC for target applications
- Pb-free lead plating; RoHS compliant (for PG-TO252: solder temperature 260°C, MSL1)
- Complete product spectrum and PSpice Models:  
<http://www.infineon.com/igbt/>



#### Applications:

- Consumer motor drives



#### Key Performance and Package Parameters

| Type      | $V_{CE}$ | $I_C$ | $V_{CEsat}, T_{vj}=25^\circ\text{C}$ | $T_{vjmax}$ | Marking | Package    |
|-----------|----------|-------|--------------------------------------|-------------|---------|------------|
| IKD04N60R | 600V     | 4A    | 1.65V                                | 175°C       | K04R60  | PG-TO252-3 |
| IKU04N60R | 600V     | 4A    | 1.65V                                | 175°C       | K04R60  | PG-TO251-3 |



**Table of Contents**

Description ..... 2

Table of Contents ..... 3

Maximum ratings ..... 4

Thermal Resistance ..... 4

Electrical Characteristics ..... 5

Electrical Characteristics diagrams ..... 8

Package Drawing PG-TO252-3 .....15

Package Drawing PG-TO251-3 .....16

Testing Conditions .....17

Revision History .....18

Disclaimer .....18

**Maximum ratings**

| Parameter   | Symbol      | Value      | Unit             |
|---|-------------|------------|------------------|
| Collector-emitter voltage   | $V_{CE}$    | 600        | V                |
| DC collector current, limited by $T_{vjmax}$<br>$T_C = 25^\circ\text{C}$<br>$T_C = 100^\circ\text{C}$   | $I_C$       | 8.0<br>4.0 | A                |
| Pulsed collector current, $t_p$ limited by $T_{vjmax}$  | $I_{Cpuls}$ | 12.0       | A                |
| Turn off safe operating area $V_{CE} \leq 600\text{V}$ , $T_{vj} \leq 175^\circ\text{C}$  | -           | 12.0       | A                |
| Diode forward current, limited by $T_{vjmax}$<br>$T_C = 25^\circ\text{C}$<br>$T_C = 100^\circ\text{C}$  | $I_F$       | 8.0<br>4.0 | A                |
| Diode pulsed current, $t_p$ limited by $T_{vjmax}$  | $I_{Fpuls}$ | 12.0       | A                |
| Gate-emitter voltage  | $V_{GE}$    | $\pm 20$   | V                |
| Short circuit withstand time<br>$V_{GE} = 15.0\text{V}$ , $V_{CC} \leq 400\text{V}$<br>Allowed number of short circuits < 1000<br>Time between short circuits: $\geq 1.0\text{s}$<br>$T_{vj} = 150^\circ\text{C}$ | $t_{SC}$    | 5          | $\mu\text{s}$    |
| Power dissipation $T_C = 25^\circ\text{C}$  | $P_{tot}$   | 75.0       | W                |
| Operating junction temperature  | $T_{vj}$    | -40...+175 | $^\circ\text{C}$ |
| Storage temperature   | $T_{stg}$   | -55...+175 | $^\circ\text{C}$ |
| Soldering temperature,<br>wave soldering 1.6 mm (0.063 in.) from case for 10s   | PG-TO251-3  | 260        | $^\circ\text{C}$ |
| reflow soldering (MSL1 according to JEDEC J-STA-020)  | PG-TO252-3  | 260        |                  |

**Thermal Resistance**

| Parameter   | Symbol        | Conditions | Max. Value | Unit |
|---|---------------|------------|------------|------|
| <b>Characteristic</b>   |               |            |            |      |
| IGBT thermal resistance, <sup>1)</sup><br>junction - case               | $R_{th(j-c)}$ |            | 2.00       | K/W  |
| Diode thermal resistance, <sup>2)</sup><br>junction - case              | $R_{th(j-c)}$ |            | 4.50       | K/W  |
| Thermal resistance, min. footprint<br>junction - ambient                | $R_{th(j-a)}$ | PG-TO252-3 | 75         | K/W  |
| Thermal resistance, 6cm <sup>2</sup> Cu on<br>PCB<br>junction - ambient | $R_{th(j-a)}$ | PG-TO252-3 | 50         | K/W  |
| Thermal resistance<br>junction - ambient                                | $R_{th(j-a)}$ | PG-TO251-3 | 75         | K/W  |

<sup>1)</sup> Rth/Zth based on single cooling pulse. Please be aware that a correct Rth measurement of the IGBT, is not possible using a thermocouple.

<sup>2)</sup> Rth/Zth based on single cooling pulse. Please be aware that a correct Rth measurement of the Diode, is not possible using a thermocouple.

**Electrical Characteristic, at  $T_{vj} = 25^{\circ}\text{C}$ , unless otherwise specified**

| Parameter   | Symbol        | Conditions  | Value  |              |                | Unit          |
|---|---------------|---|--------|--------------|----------------|---------------|
|   |               |   | min.   | typ.         | max.           |               |
| <b>Static Characteristic</b>                      |               |   |        |              |                |               |
| Collector-emitter breakdown voltage               | $V_{(BR)CES}$ | $V_{GE} = 0\text{V}, I_C = 0.20\text{mA}$   | 600    | -            | -              | V             |
| Collector-emitter saturation voltage              | $V_{CEsat}$   | $V_{GE} = 15.0\text{V}, I_C = 4.0\text{A}$<br>$T_{vj} = 25^{\circ}\text{C}$<br>$T_{vj} = 175^{\circ}\text{C}$ | -<br>- | 1.65<br>1.85 | 2.10<br>-      | V             |
| Diode forward voltage                             | $V_F$         | $V_{GE} = 0\text{V}, I_F = 4.0\text{A}$<br>$T_{vj} = 25^{\circ}\text{C}$<br>$T_{vj} = 175^{\circ}\text{C}$    | -<br>- | 1.70<br>1.70 | 2.10           | V             |
| Gate-emitter threshold voltage                    | $V_{GE(th)}$  | $I_C = 0.07\text{mA}, V_{CE} = V_{GE}$  | 4.3    | 5.0          | 5.7            | V             |
| Zero gate voltage collector current <sup>1)</sup> | $I_{CES}$     | $V_{CE} = 600\text{V}, V_{GE} = 0\text{V}$<br>$T_{vj} = 25^{\circ}\text{C}$<br>$T_{vj} = 175^{\circ}\text{C}$ | -<br>- | -<br>-       | 40.0<br>1000.0 | $\mu\text{A}$ |
| Gate-emitter leakage current                      | $I_{GES}$     | $V_{CE} = 0\text{V}, V_{GE} = 20\text{V}$   | -      | -            | 100            | nA            |
| Transconductance                                  | $g_{fs}$      | $V_{CE} = 20\text{V}, I_C = 4.0\text{A}$  | -      | 2.2          | -              | S             |
| Integrated gate resistor                          | $r_G$         |   |        | none         |                | $\Omega$      |

**Electrical Characteristic, at  $T_{vj} = 25^{\circ}\text{C}$ , unless otherwise specified**

| Parameter  | Symbol      | Conditions   | Value |          |      | Unit |
|--|-------------|--|-------|----------|------|------|
|  |             |  | min.  | typ.     | max. |      |
| <b>Dynamic Characteristic</b>  |             |  |       |          |      |      |
| Input capacitance  | $C_{ies}$   | $V_{CE} = 25\text{V}, V_{GE} = 0\text{V}, f = 1\text{MHz}$   | -     | 305      | -    | pF   |
| Output capacitance   | $C_{oes}$   |  | -     | 18       | -    |      |
| Reverse transfer capacitance   | $C_{res}$   |  | -     | 9        | -    |      |
| Gate charge  | $Q_G$       | $V_{CC} = 480\text{V}, I_C = 4.0\text{A},$<br>$V_{GE} = 15\text{V}$  | -     | 27.0     | -    | nC   |
| Internal emitter inductance<br>measured 5mm (0.197 in.) from case  | $L_E$       | PG-TO252-3<br>PG-TO251-3   | -     | -<br>7.0 | -    | nH   |
| Short circuit collector current<br>Max. 1000 short circuits<br>Time between short circuits: $\geq 1.0\text{s}$ | $I_{C(SC)}$ | $V_{GE} = 15.0\text{V}, V_{CC} \leq 400\text{V},$<br>$t_{SC} \leq 5\mu\text{s}$<br>$T_{vj} = 25^{\circ}\text{C}$ | -     | 31       | -    | A    |

<sup>1)</sup> Not subject to production test - verified by design/characterization

**Switching Characteristic, Inductive Load, at  $T_{vj} = 25^{\circ}\text{C}$** 

| Parameter                  | Symbol       | Conditions   | Value |      |      | Unit |
|----------------------------|--------------|--|-------|------|------|------|
|                            |              |  | min.  | typ. | max. |      |
| <b>IGBT Characteristic</b> |              |  |       |      |      |      |
| Turn-on delay time         | $t_{d(on)}$  | $T_{vj} = 25^{\circ}\text{C}$ ,<br>$V_{CC} = 400\text{V}$ , $I_C = 4.0\text{A}$ ,<br>$V_{GE} = 0.0/15.0\text{V}$ ,<br>$r_G = 43.0\Omega$ , $L_{\sigma} = 60\text{nH}$ ,<br>$C_{\sigma} = 40\text{pF}$<br>$L_{\sigma}$ , $C_{\sigma}$ from Fig. E | -     | 14   | -    | ns   |
| Rise time                  | $t_r$        |  | -     | 8    | -    | ns   |
| Turn-off delay time        | $t_{d(off)}$ |  | -     | 146  | -    | ns   |
| Fall time                  | $t_f$        |  | -     | 171  | -    | ns   |
| Turn-on energy             | $E_{on}$     |  | -     | 0.09 | -    | mJ   |
| Turn-off energy            | $E_{off}$    |  | -     | 0.15 | -    | mJ   |
| Total switching energy     | $E_{ts}$     |  | -     | 0.24 | -    | mJ   |

**Diode Characteristic, at  $T_{vj} = 25^{\circ}\text{C}$** 

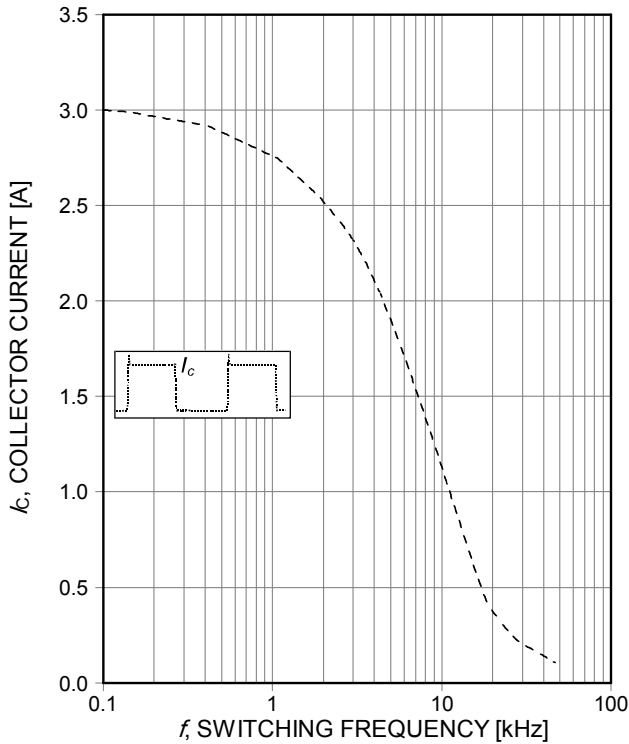
|  |              |  |   |      |   |                        |
|--|--------------|--|---|------|---|------------------------|
| Diode reverse recovery time                                      | $t_{rr}$     | $T_{vj} = 25^{\circ}\text{C}$ ,<br>$V_R = 400\text{V}$ ,<br>$I_F = 4.0\text{A}$ ,<br>$di_F/dt = 600\text{A}/\mu\text{s}$ | - | 43   | - | ns                     |
| Diode reverse recovery charge                                    | $Q_{rr}$     |  | - | 0.22 | - | $\mu\text{C}$          |
| Diode peak reverse recovery current                              | $I_{rrm}$    |  | - | 7.6  | - | A                      |
| Diode peak rate of fall of reverse recovery current during $t_b$ | $di_{rr}/dt$ |  | - | -330 | - | $\text{A}/\mu\text{s}$ |

**Switching Characteristic, Inductive Load, at  $T_{vj} = 175^{\circ}\text{C}$** 

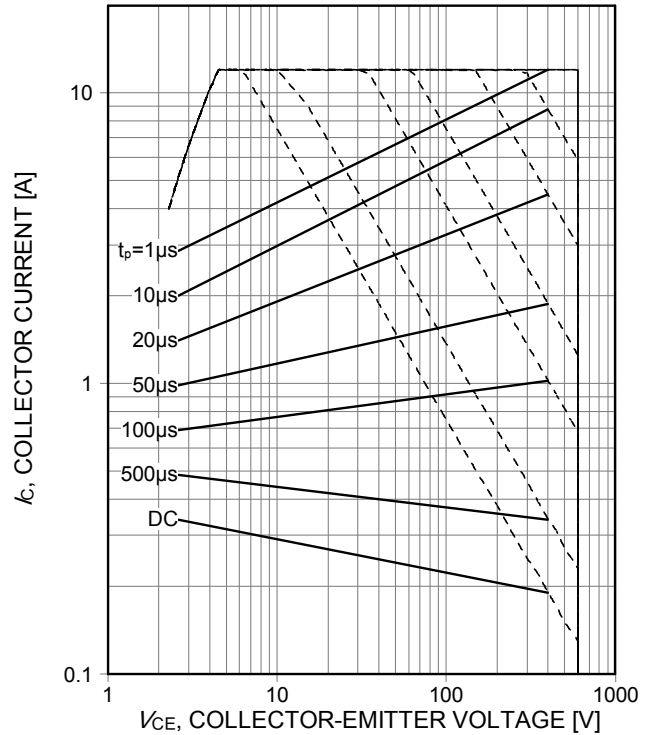
| Parameter                  | Symbol       | Conditions  | Value |      |      | Unit |
|----------------------------|--------------|---|-------|------|------|------|
|                            |              |   | min.  | typ. | max. |      |
| <b>IGBT Characteristic</b> |              |   |       |      |      |      |
| Turn-on delay time         | $t_{d(on)}$  | $T_{vj} = 175^{\circ}\text{C}$ ,<br>$V_{CC} = 400\text{V}$ , $I_C = 4.0\text{A}$ ,<br>$V_{GE} = 0.0/15.0\text{V}$ ,<br>$r_G = 43.0\Omega$ , $L_{\sigma} = 60\text{nH}$ ,<br>$C_{\sigma} = 40\text{pF}$<br>$L_{\sigma}$ , $C_{\sigma}$ from Fig. E | -     | 12   | -    | ns   |
| Rise time                  | $t_r$        |   | -     | 8    | -    | ns   |
| Turn-off delay time        | $t_{d(off)}$ |   | -     | 177  | -    | ns   |
| Fall time                  | $t_f$        |   | -     | 165  | -    | ns   |
| Turn-on energy             | $E_{on}$     |   | -     | 0.16 | -    | mJ   |
| Turn-off energy            | $E_{off}$    |   | -     | 0.24 | -    | mJ   |
| Total switching energy     | $E_{ts}$     |   | -     | 0.40 | -    | mJ   |

**Diode Characteristic, at  $T_{vj} = 175^{\circ}\text{C}$** 

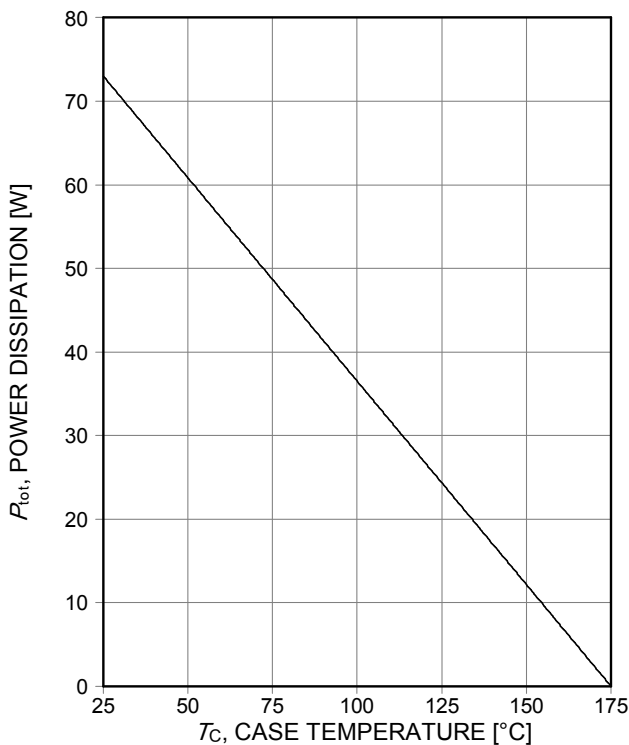
|  |              |   |   |      |   |                        |
|--|--------------|---|---|------|---|------------------------|
| Diode reverse recovery time                                      | $t_{rr}$     | $T_{vj} = 175^{\circ}\text{C}$ ,<br>$V_R = 400\text{V}$ ,<br>$I_F = 4.0\text{A}$ ,<br>$di_F/dt = 600\text{A}/\mu\text{s}$ | - | 98   | - | ns                     |
| Diode reverse recovery charge                                    | $Q_{rr}$     |   | - | 0.52 | - | $\mu\text{C}$          |
| Diode peak reverse recovery current                              | $I_{rrm}$    |   | - | 11.0 | - | A                      |
| Diode peak rate of fall of reverse recovery current during $t_b$ | $di_{rr}/dt$ |   | - | -200 | - | $\text{A}/\mu\text{s}$ |



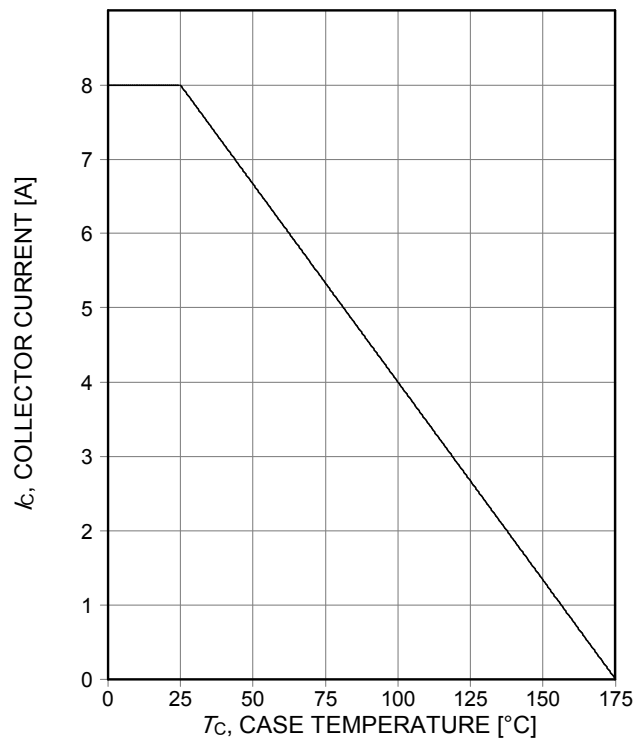
**Figure 1. Collector current as a function of switching frequency**  
 ( $T_{vj} \leq 175^\circ\text{C}$ ,  $T_a = 55^\circ\text{C}$ ,  $D = 0.5$ ,  $V_{CE} = 400\text{V}$ ,  
 $V_{GE} = 15/0\text{V}$ ,  $r_G = 43\Omega$ , PCB mounting, 6cm<sup>2</sup> Cu, Ptot=2,4W)



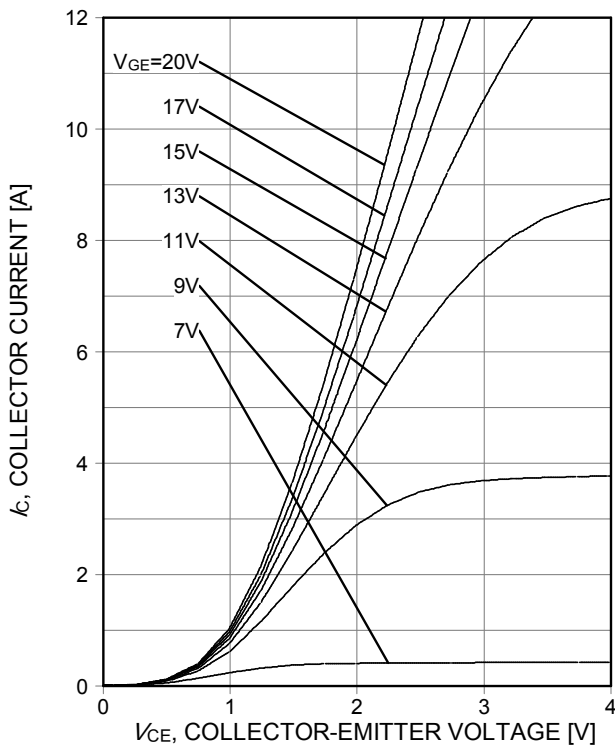
**Figure 2. Forward bias safe operating area**  
 ( $D = 0$ ,  $T_C = 25^\circ\text{C}$ ,  $T_{vj} \leq 175^\circ\text{C}$ ;  $V_{GE} = 15\text{V}$ )



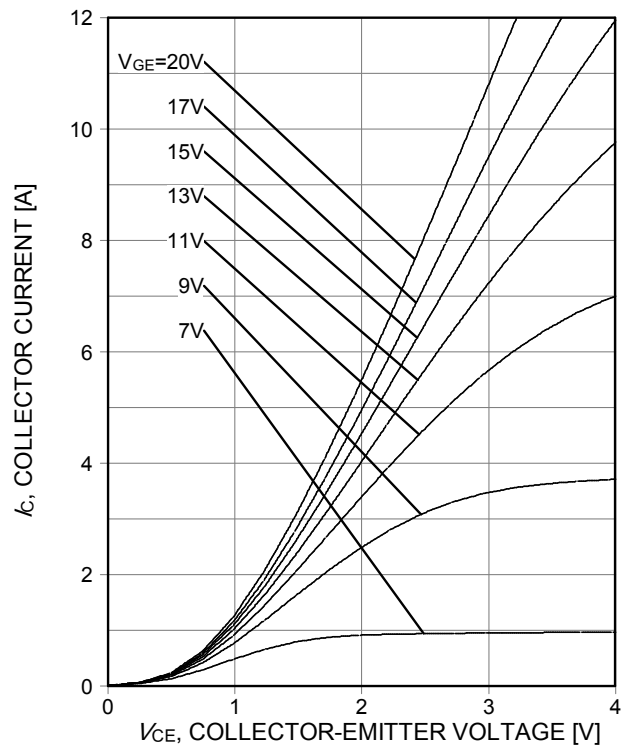
**Figure 3. Power dissipation as a function of case temperature**  
 ( $T_{vj} \leq 175^\circ\text{C}$ )



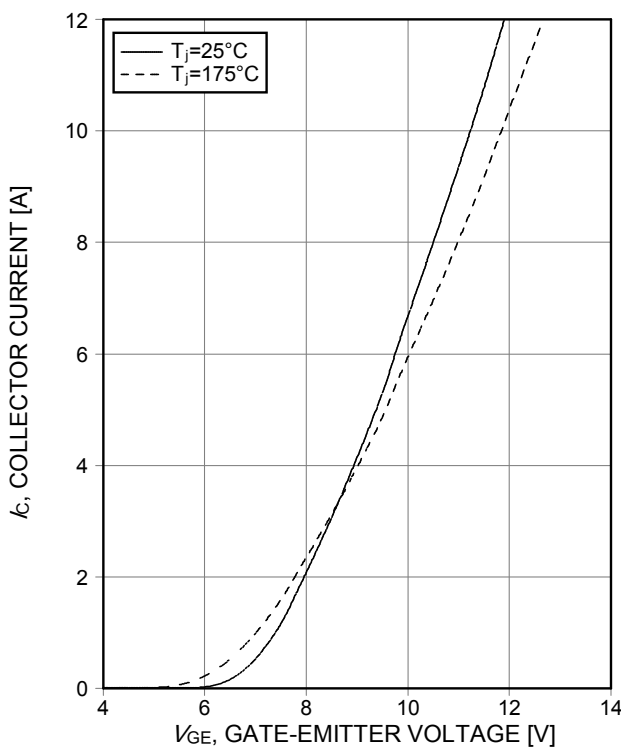
**Figure 4. Collector current as a function of case temperature**  
 ( $V_{GE} \geq 15\text{V}$ ,  $T_{vj} \leq 175^\circ\text{C}$ )



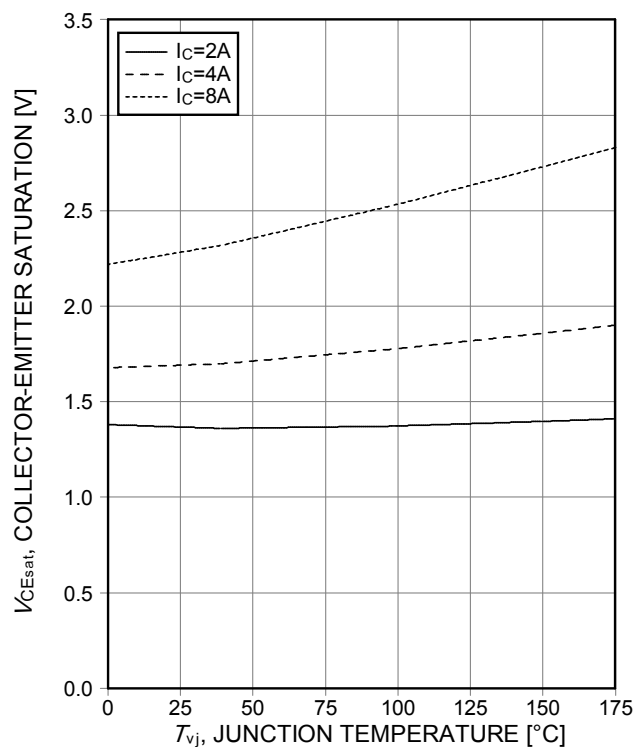
**Figure 5. Typical output characteristic**  
( $T_{vj}=25^{\circ}\text{C}$ )



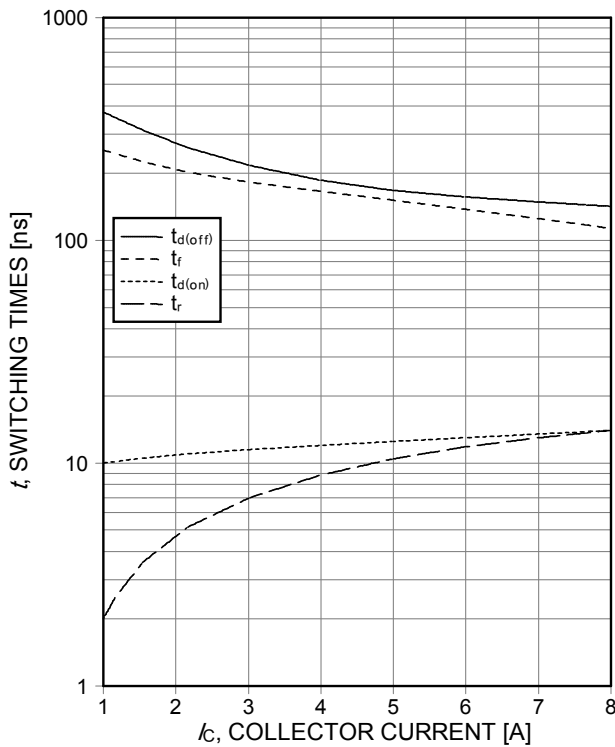
**Figure 6. Typical output characteristic**  
( $T_{vj}=175^{\circ}\text{C}$ )



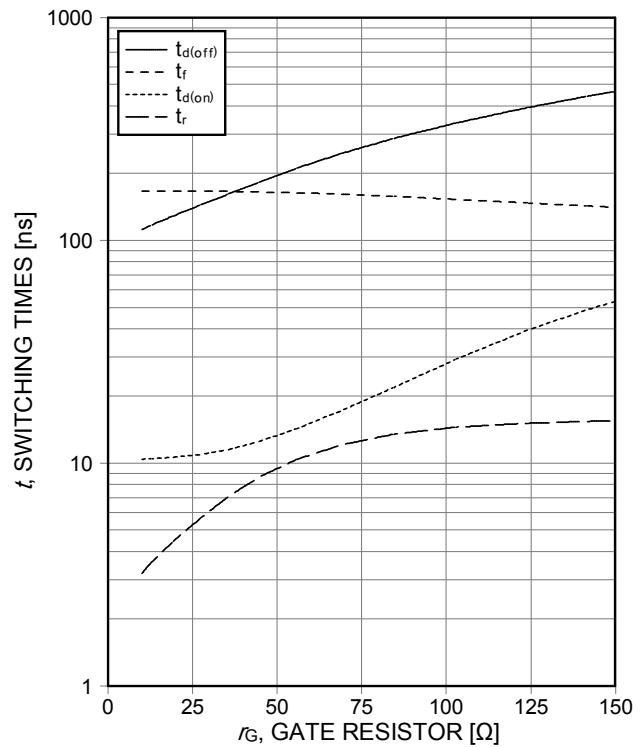
**Figure 7. Typical transfer characteristic**  
( $V_{ce}=10\text{V}$ )



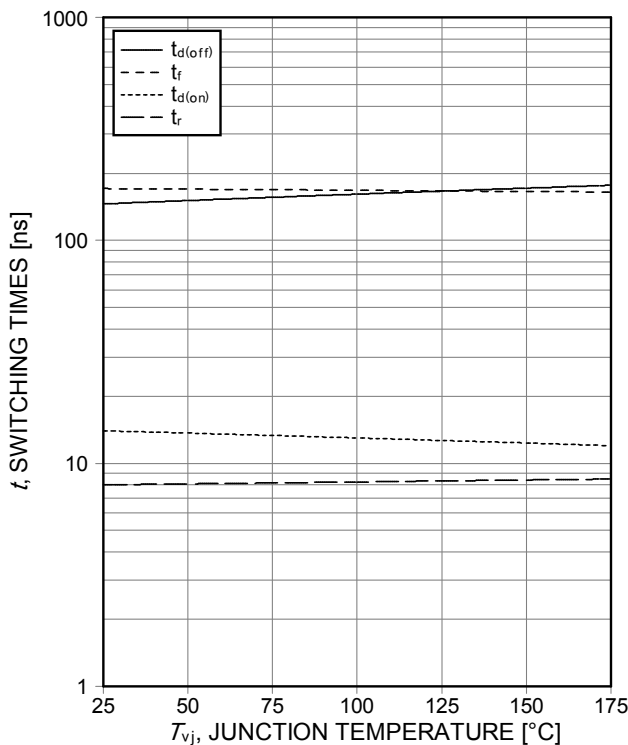
**Figure 8. Typical collector-emitter saturation voltage as a function of junction temperature**  
( $V_{ge}=15\text{V}$ )



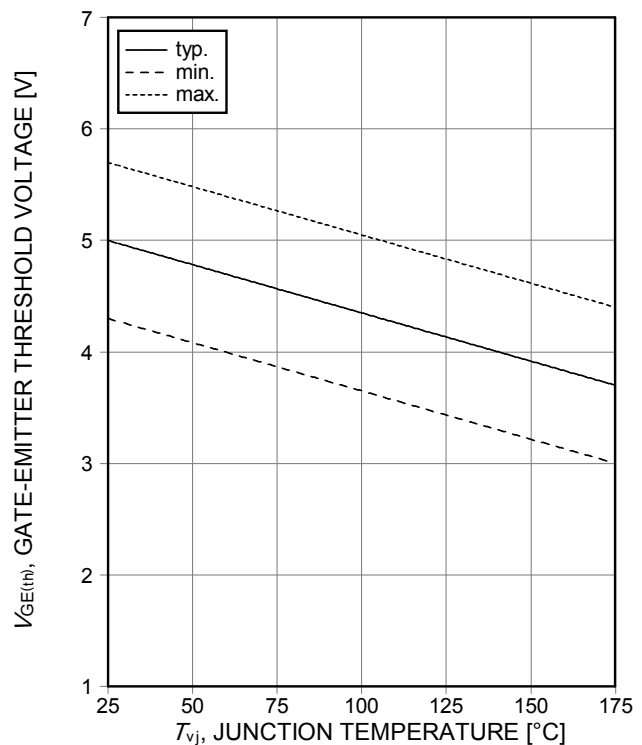
**Figure 9. Typical switching times as a function of collector current**  
 (inductive load,  $T_{vj}=175^{\circ}\text{C}$ ,  $V_{CE}=400\text{V}$ ,  $V_{GE}=15/0\text{V}$ ,  $r_G=43\Omega$ , Dynamic test circuit in Figure E)



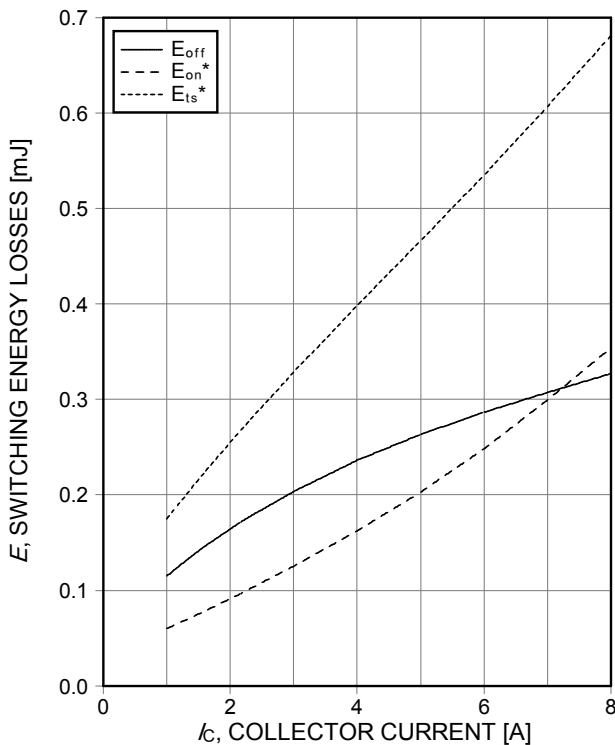
**Figure 10. Typical switching times as a function of gate resistor**  
 (inductive load,  $T_{vj}=175^{\circ}\text{C}$ ,  $V_{CE}=400\text{V}$ ,  $V_{GE}=15/0\text{V}$ ,  $I_C=4\text{A}$ , Dynamic test circuit in Figure E)



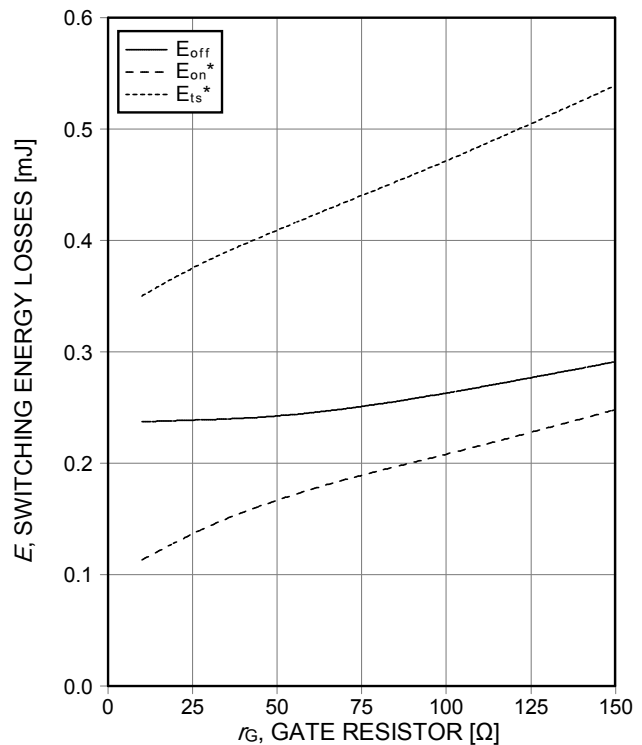
**Figure 11. Typical switching times as a function of junction temperature**  
 (inductive load,  $V_{CE}=400\text{V}$ ,  $V_{GE}=15/0\text{V}$ ,  $I_C=4\text{A}$ ,  $r_G=43\Omega$ , Dynamic test circuit in Figure E)



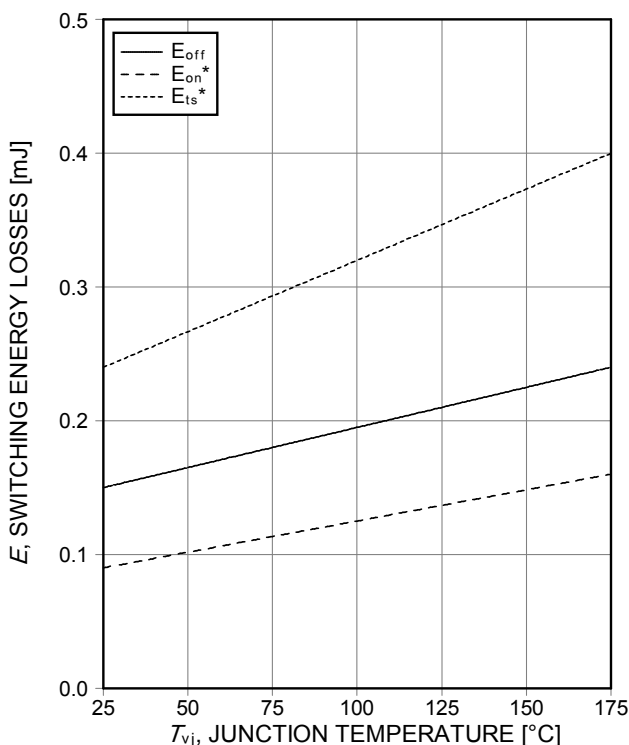
**Figure 12. Gate-emitter threshold voltage as a function of junction temperature**  
 ( $I_C=0,07\text{mA}$ )



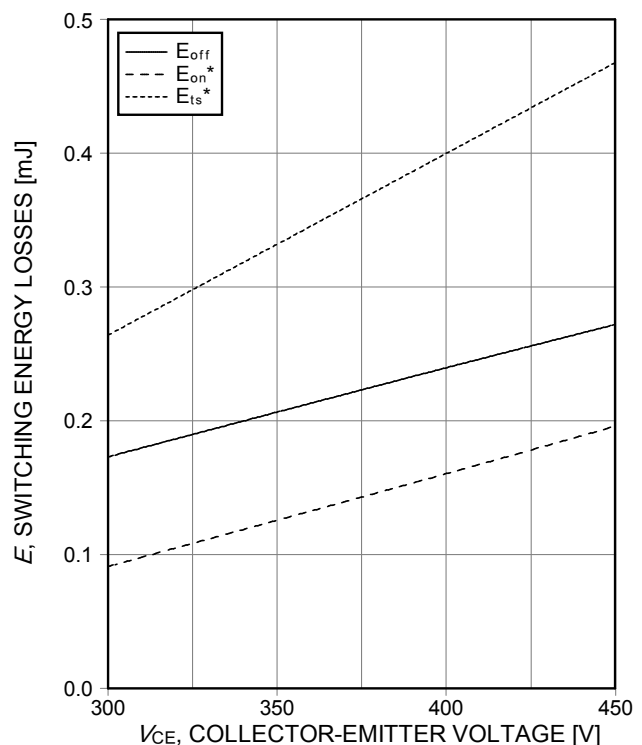
**Figure 13. Typical switching energy losses as a function of collector current**  
 (inductive load,  $T_{vj}=175^{\circ}\text{C}$ ,  $V_{CE}=400\text{V}$ ,  $V_{GE}=15/0\text{V}$ ,  $r_G=43\Omega$ , Dynamic test circuit in Figure E)



**Figure 14. Typical switching energy losses as a function of gate resistor**  
 (inductive load,  $T_{vj}=175^{\circ}\text{C}$ ,  $V_{CE}=400\text{V}$ ,  $V_{GE}=15/0\text{V}$ ,  $I_C=4\text{A}$ , Dynamic test circuit in Figure E)



**Figure 15. Typical switching energy losses as a function of junction temperature**  
 (inductive load,  $V_{CE}=400\text{V}$ ,  $V_{GE}=15/0\text{V}$ ,  $I_C=4\text{A}$ ,  $r_G=43\Omega$ , Dynamic test circuit in Figure E)



**Figure 16. Typical switching energy losses as a function of collector emitter voltage**  
 (inductive load,  $T_{vj}=175^{\circ}\text{C}$ ,  $V_{GE}=15/0\text{V}$ ,  $I_C=4\text{A}$ ,  $r_G=43\Omega$ , Dynamic test circuit in Figure E)

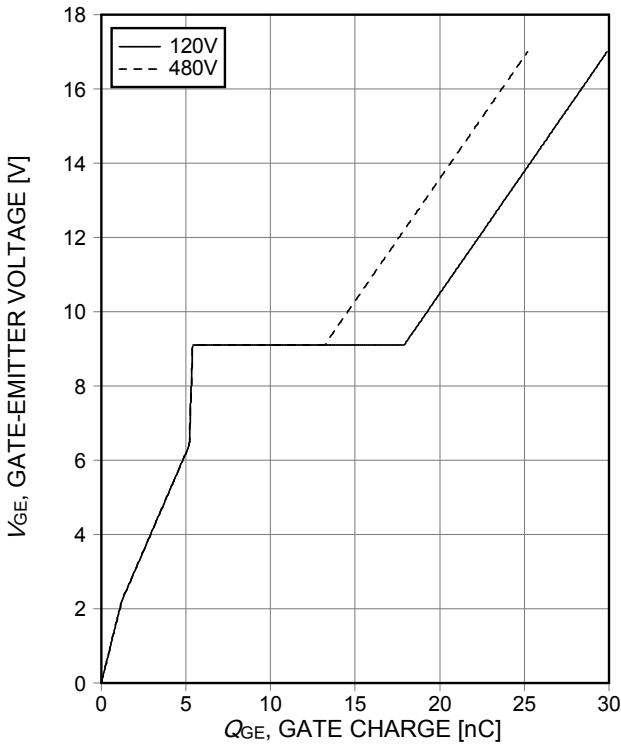


Figure 17. Typical gate charge  
( $I_C=4A$ )

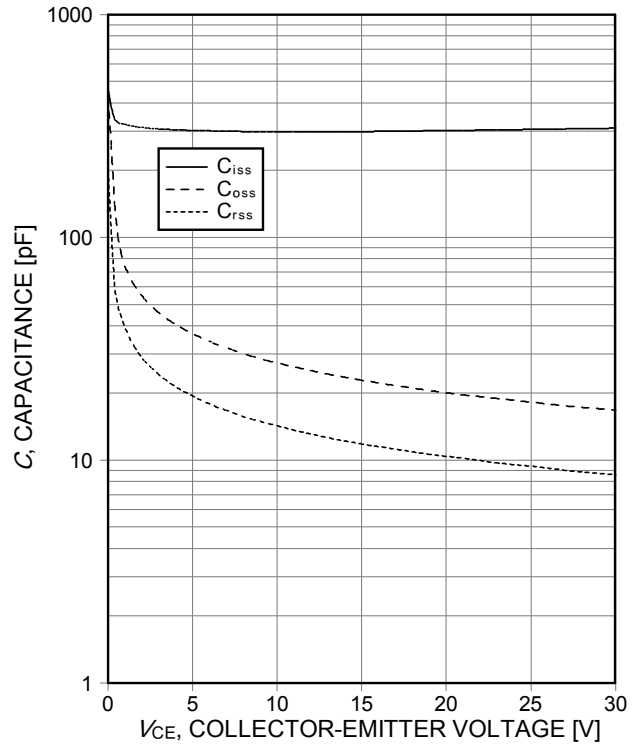


Figure 18. Typical capacitance as a function of collector-emitter voltage  
( $V_{GE}=0V$ ,  $f=1MHz$ )

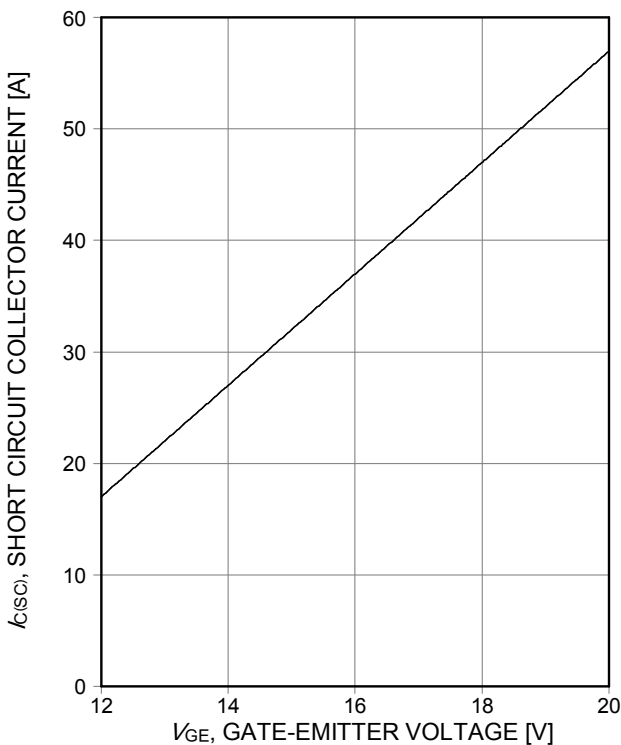


Figure 19. Typical short circuit collector current as a function of gate-emitter voltage  
( $V_{CE}\leq 400V$ , start at  $T_{vj}=25^\circ C$ )

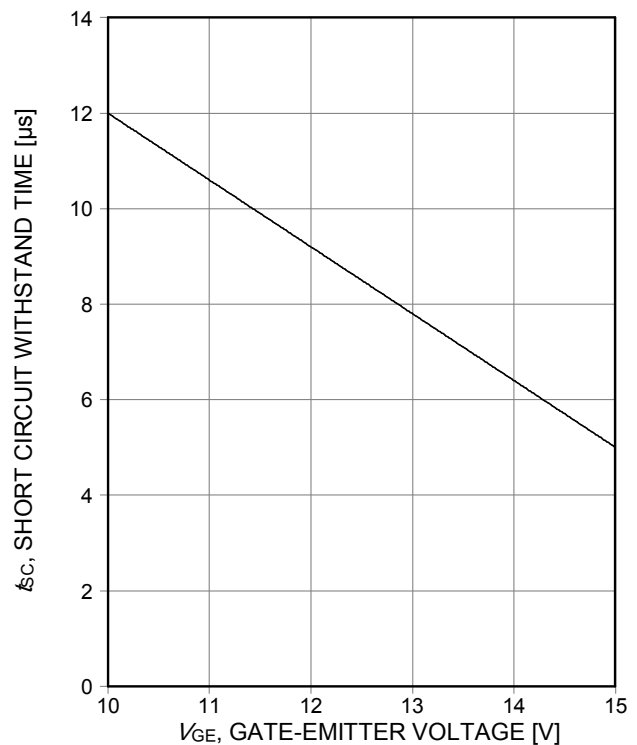


Figure 20. Short circuit withstand time as a function of gate-emitter voltage  
( $V_{CE}\leq 400V$ , start at  $T_{vj}=150^\circ C$ )

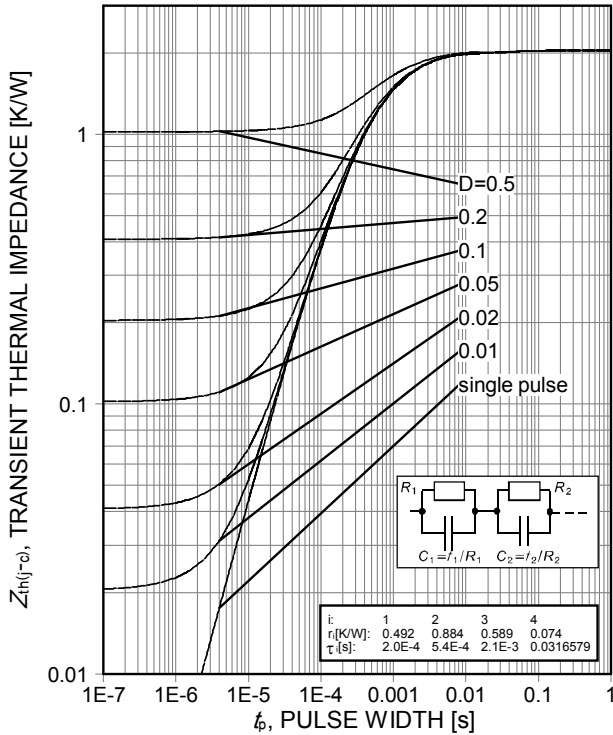


Figure 21. IGBT transient thermal impedance as a function of pulse width <sup>1)</sup> (see page 4) ( $D = t_p/T$ )

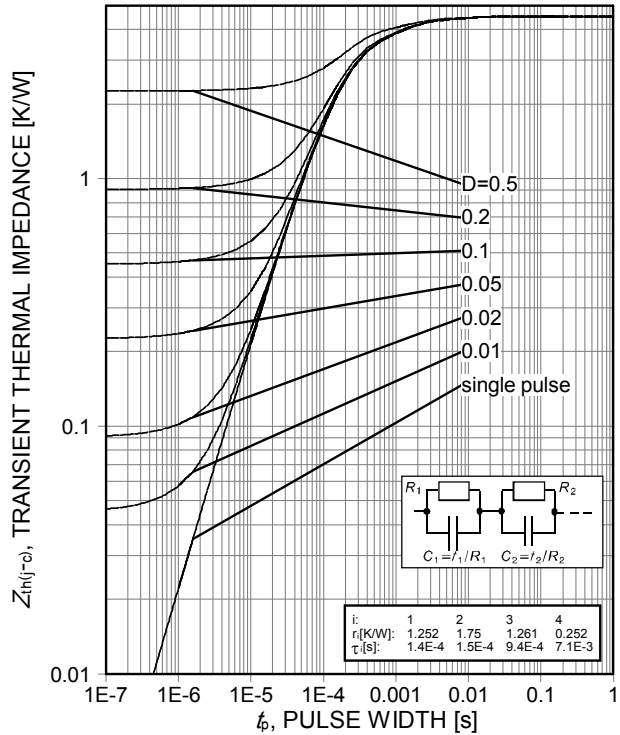


Figure 22. Diode transient thermal impedance as a function of pulse width <sup>2)</sup> (see page 4) ( $D = t_p/T$ )

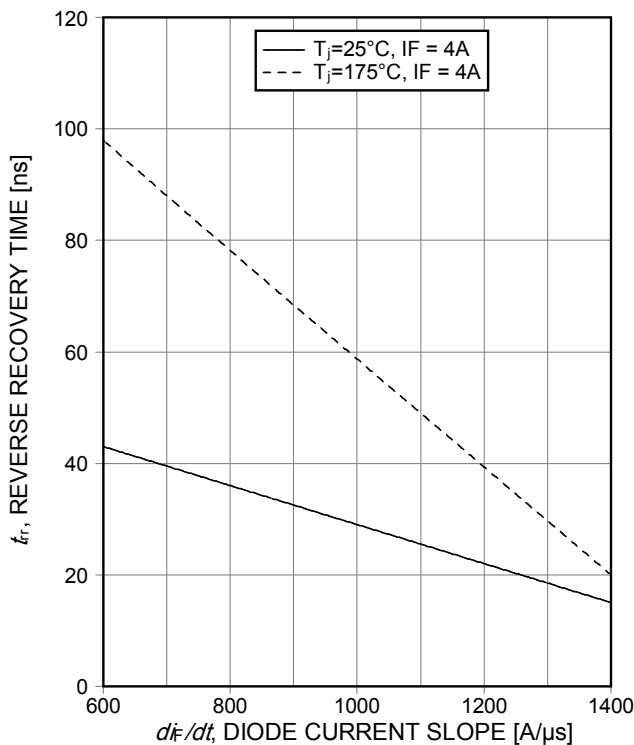


Figure 23. Typical reverse recovery time as a function of diode current slope ( $V_R = 400V$ )

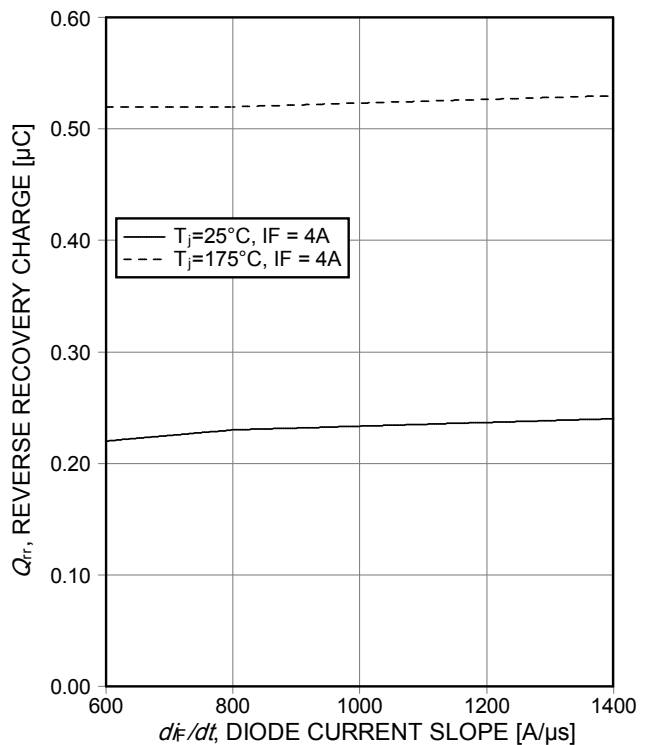
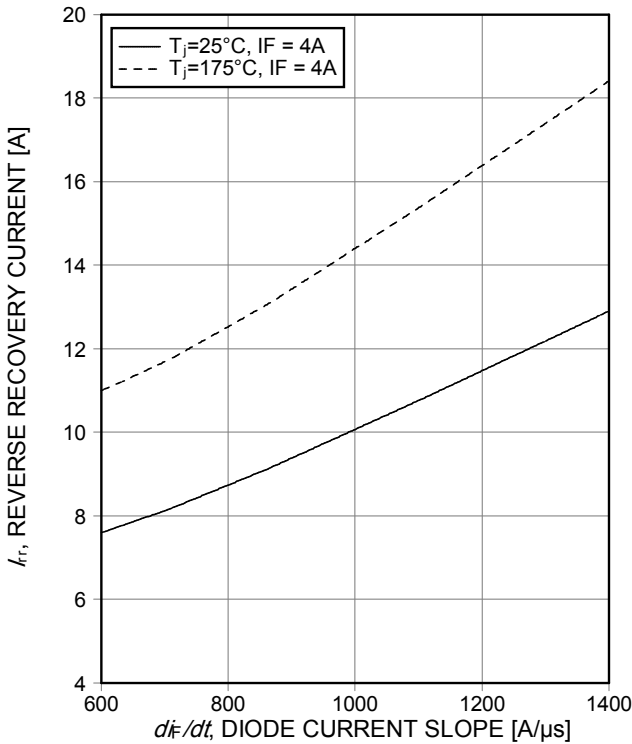
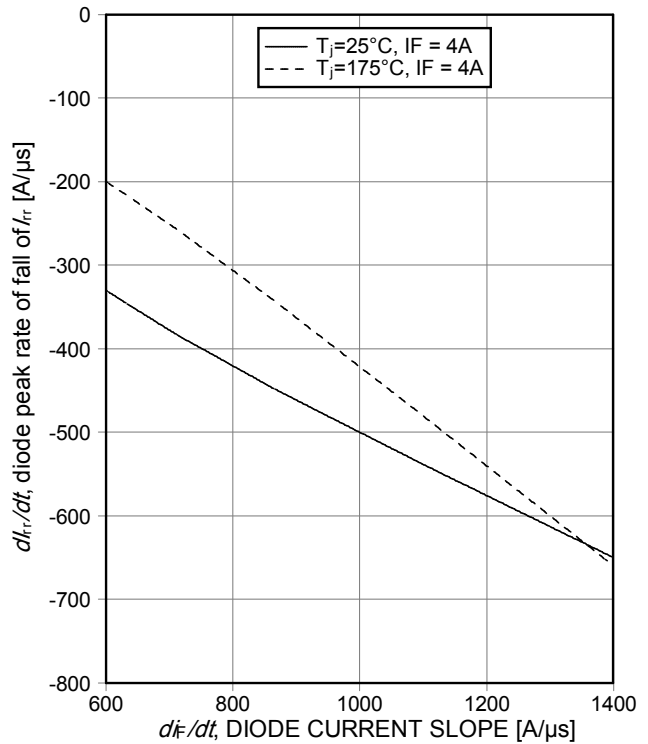


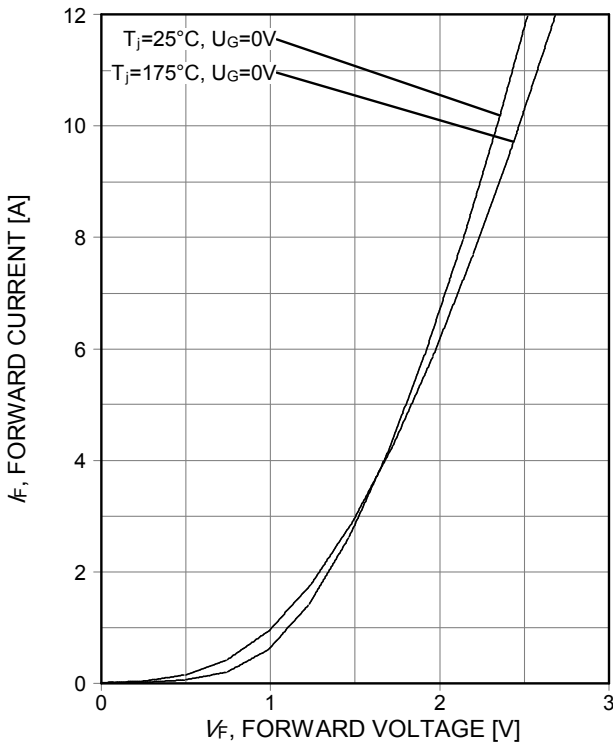
Figure 24. Typical reverse recovery charge as a function of diode current slope ( $V_R = 400V$ )



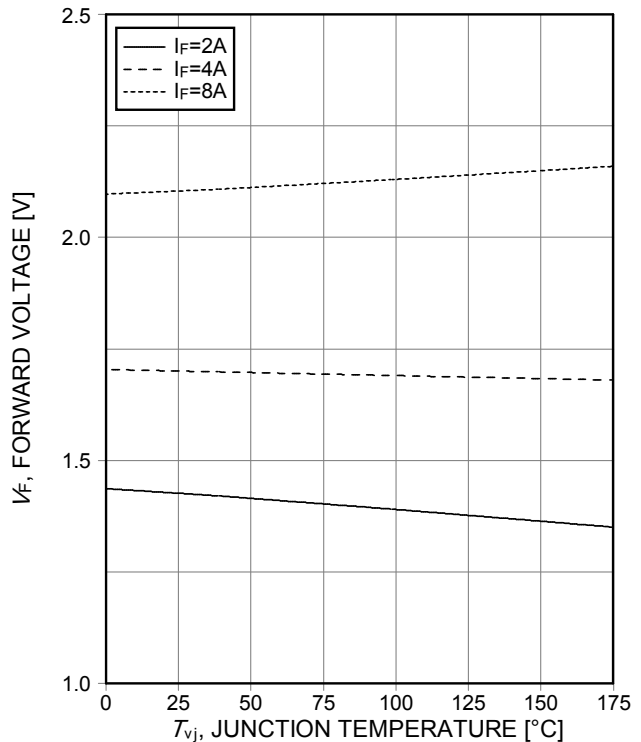
**Figure 25. Typical reverse recovery current as a function of diode current slope**  
( $V_R=400V$ )



**Figure 26. Typical diode peak rate of fall of reverse recovery current as a function of diode current slope**  
( $V_R=400V$ )

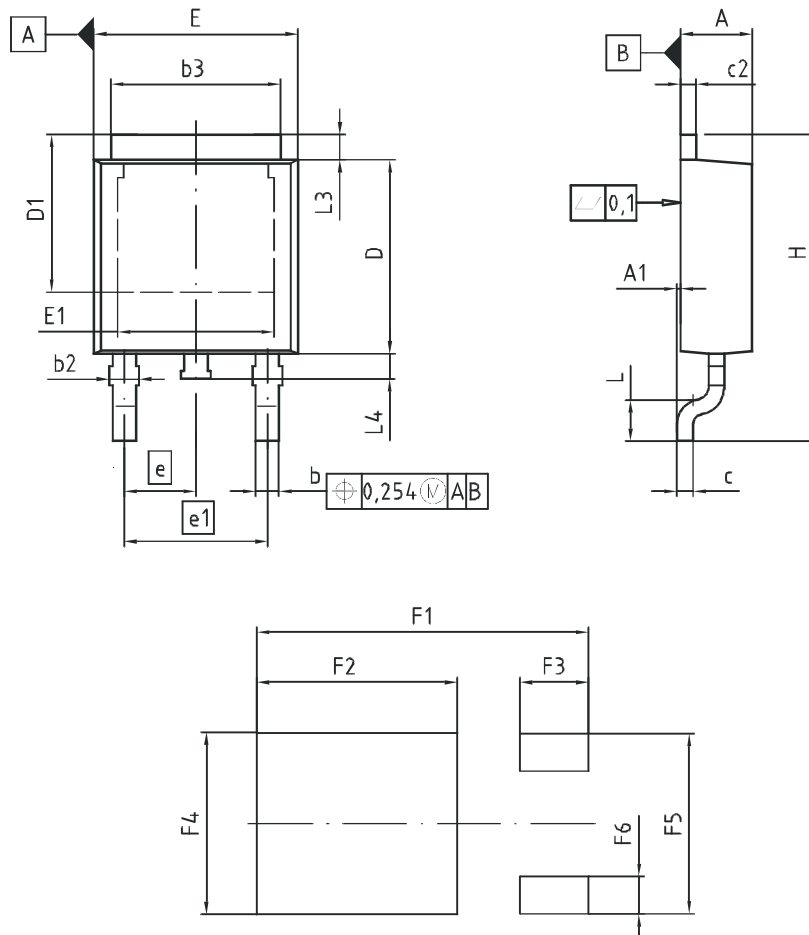


**Figure 27. Typical diode forward current as a function of forward voltage**



**Figure 28. Typical diode forward voltage as a function of junction temperature**

PG- TO252-3



| DIM | MILLIMETERS |       | INCHES |       |
|-----|-------------|-------|--------|-------|
|     | MIN         | MAX   | MIN    | MAX   |
| A   | 2.16        | 2.41  | 0.085  | 0.095 |
| A1  | 0.00        | 0.15  | 0.000  | 0.006 |
| b   | 0.64        | 0.89  | 0.025  | 0.035 |
| b2  | 0.65        | 1.15  | 0.026  | 0.045 |
| b3  | 5.00        | 5.50  | 0.197  | 0.217 |
| c   | 0.46        | 0.60  | 0.018  | 0.024 |
| c2  | 0.46        | 0.98  | 0.018  | 0.039 |
| D   | 5.97        | 6.22  | 0.235  | 0.245 |
| D1  | 5.02        | 5.84  | 0.198  | 0.230 |
| E   | 6.40        | 6.73  | 0.252  | 0.265 |
| E1  | 4.70        | 5.21  | 0.185  | 0.205 |
| e   | 2.29        |       | 0.090  |       |
| e1  | 4.57        |       | 0.180  |       |
| N   | 3           |       | 3      |       |
| H   | 9.40        | 10.48 | 0.370  | 0.413 |
| L   | 1.18        | 1.70  | 0.046  | 0.067 |
| L3  | 0.90        | 1.25  | 0.035  | 0.049 |
| L4  | 0.51        | 1.00  | 0.020  | 0.039 |
| F1  | 10.50       | 10.70 | 0.413  | 0.421 |
| F2  | 6.30        | 6.50  | 0.248  | 0.256 |
| F3  | 2.10        | 2.30  | 0.083  | 0.091 |
| F4  | 5.70        | 5.90  | 0.224  | 0.232 |
| F5  | 5.66        | 5.86  | 0.223  | 0.231 |
| F6  | 1.10        | 1.30  | 0.043  | 0.051 |

DOCUMENT NO.  
Z8B00003328

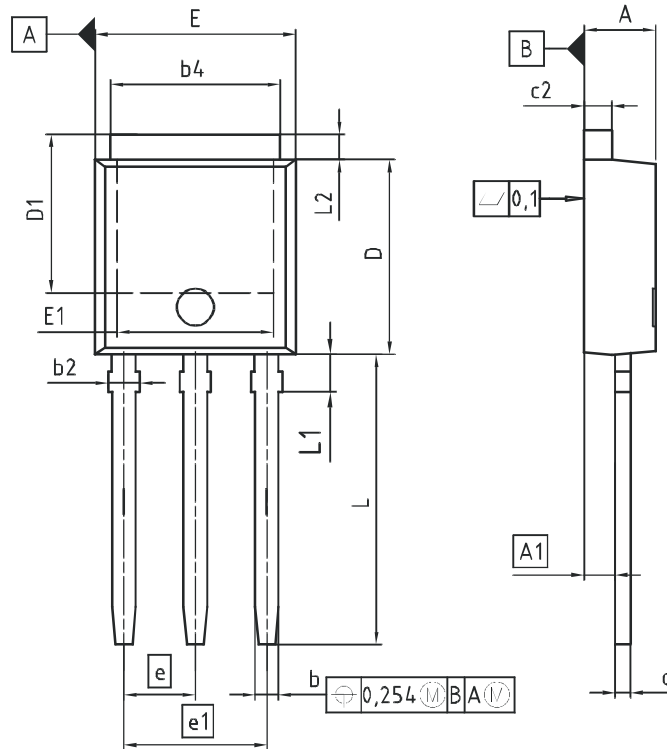
SCALE 0 2.0 4mm

EUROPEAN PROJECTION

ISSUE DATE  
19-10-2007

REVISION  
03

PG-TO251-3



| DIM | MILLIMETERS |      | INCHES |       |
|-----|-------------|------|--------|-------|
|     | MIN         | MAX  | MIN    | MAX   |
| A   | 2.16        | 2.41 | 0.085  | 0.095 |
| A1  | 0.90        | 1.14 | 0.035  | 0.045 |
| b   | 0.64        | 0.89 | 0.025  | 0.035 |
| b2  | 0.65        | 1.15 | 0.026  | 0.045 |
| b4  | 4.95        | 5.50 | 0.195  | 0.217 |
| c   | 0.46        | 0.60 | 0.018  | 0.024 |
| c2  | 0.46        | 0.89 | 0.018  | 0.035 |
| D   | 5.97        | 6.22 | 0.235  | 0.245 |
| D1  | 5.04        | 5.77 | 0.198  | 0.227 |
| E   | 6.35        | 6.73 | 0.250  | 0.265 |
| E1  | 4.70        | 5.21 | 0.185  | 0.205 |
| e   | 2.29        |      | 0.090  |       |
| e1  | 4.57        |      | 0.180  |       |
| N   | 3           |      | 3      |       |
| L   | 8.89        | 9.65 | 0.350  | 0.380 |
| L1  | 1.90        | 2.29 | 0.075  | 0.090 |
| L2  | 0.89        | 1.37 | 0.035  | 0.054 |

DOCUMENT NO.  
Z8B00003330

SCALE

EUROPEAN PROJECTION

ISSUE DATE  
19-03-2008

REVISION  
03

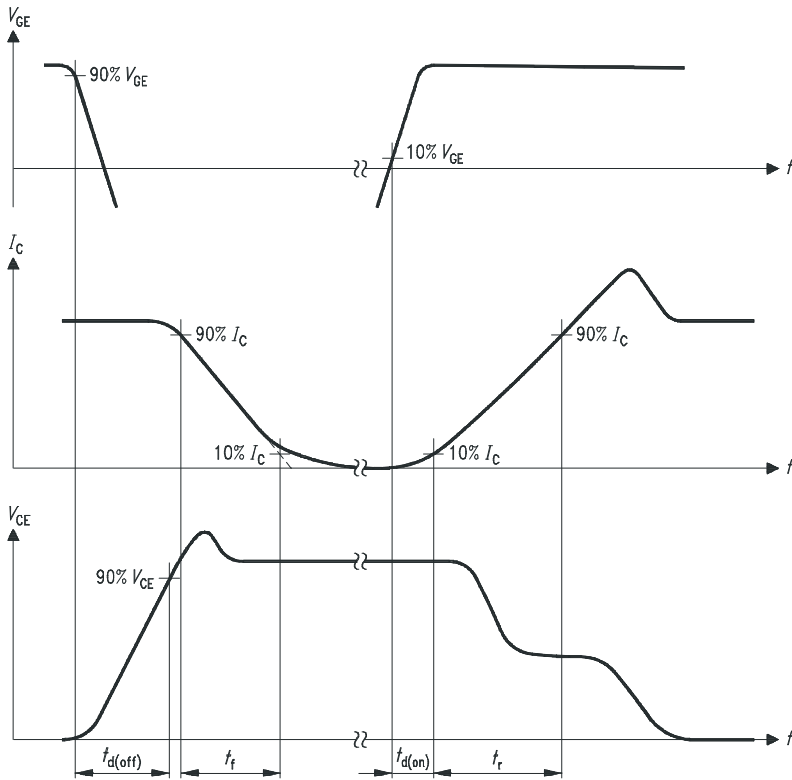


Figure A. Definition of switching times

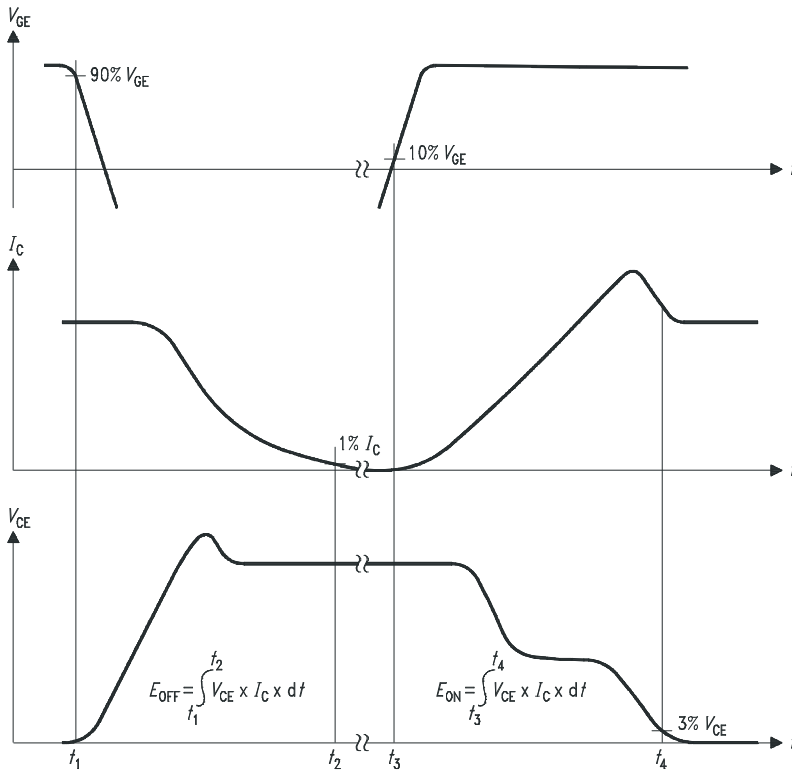


Figure B. Definition of switching losses

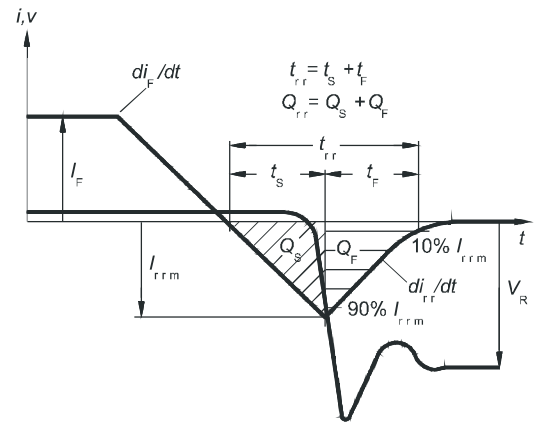


Figure C. Definition of diodes switching characteristics

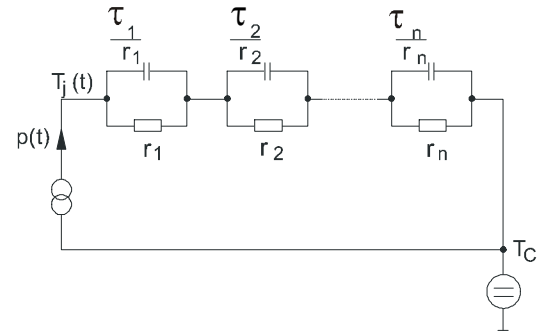


Figure D. Thermal equivalent circuit

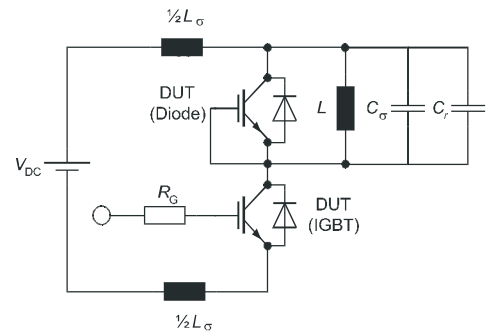


Figure E. Dynamic test circuit  
Parasitic inductance  $L_{\sigma}$ ,  
Parasitic capacitor  $C_{\sigma}$ ,  
Relief capacitor  $C_r$   
(only for ZVT switching)



**Revision History**

IKD04N60R, IKU04N60R

**Revision: 2011-01-17, Rev. 2.1**

Previous Revision

| Revision | Date       | Subjects (major changes since last revision) |
|----------|------------|--|
| 1.2      | 2010-01-12 | -  |
| 2.1      | -          | Release of final datasheet                   |

**We Listen to Your Comments**

Any information within this document that you feel is wrong, unclear or missing at all ?

Your feedback will help us to continuously improve the quality of this document.

Please send your proposal (including a reference to this document) to: [erratum@infineon.com](mailto:erratum@infineon.com)

**Published by**

**Infineon Technologies AG**

**81726 Munich, Germany**

**81726 München, Germany**

**© 2010 Infineon Technologies AG**

**All Rights Reserved.**

**Legal Disclaimer**

The information given in this document shall in no event be regarded as a guarantee of conditions or characteristics. With respect to any examples or hints given herein, any typical values stated herein and/or any information regarding the application of the device, Infineon Technologies hereby disclaims any and all warranties and liabilities of any kind, including without limitation, warranties of non-infringement of intellectual property rights of any third party.

**Information**



For further information on technology, delivery terms and conditions and prices, please contact the nearest Infineon Technologies Office ([www.infineon.com](http://www.infineon.com)).

**Warnings**

Due to technical requirements, components may contain dangerous substances. For information on the types in question, please contact the nearest Infineon Technologies Office. Infineon Technologies components may be used in life-support devices or systems only with the express written approval of Infineon Technologies, if a failure of such components can reasonably be expected to cause the failure of that life-support device or system or to affect the safety or effectiveness of that device or system. Life support devices or systems are intended to be implanted in the human body or to support and/or maintain and sustain and/or protect human life. If they fail, it is reasonable to assume that the health of the user or other persons may be endangered.

## Looking for pricing, stock, or lifecycle information?

Click below to explore more details on WIN SOURCE:

-  [View IKU04N60RBKMA1 on WIN SOURCE](#)
-  [Infineon Technologies Information](#)

## Optimize Your Supply Chain with WIN SOURCE Solutions

-  Global Sourcing Solution
-  Obsolete Management
-  Cost Control Management
-  Shortage Management
-  Alternative Solution
-  Excess Inventory Management