



THE DATASHEET OF
6N137F



(6N137)

DEGITAL LOGIC ISOLATION.

TELE-COMMUNICATION.

ANALOG DATA EQUIPMENT CONTROL

The TOSHIBA 6N137 consist of a high emitting diode and a one chip photo IC. This unit is 8-lead DIP package.

- LSTTL/TTL Compatible : 5V Supply
- Ultra High Speed : 10 MBd
- Guaranteed Performance Over Temperature : 0 °C to 70 °C
- High Isolation Voltage : 2500Vrms Min.
- UL Recognized : UL1577, File No. E67349

PIN CONFIGURATIONS (TOP VIEW)

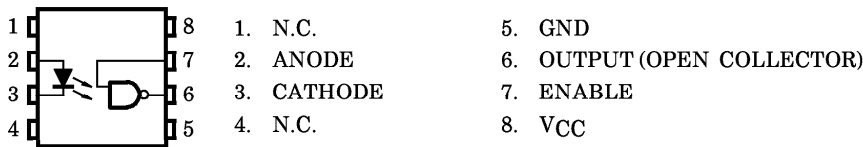

Unit in mm

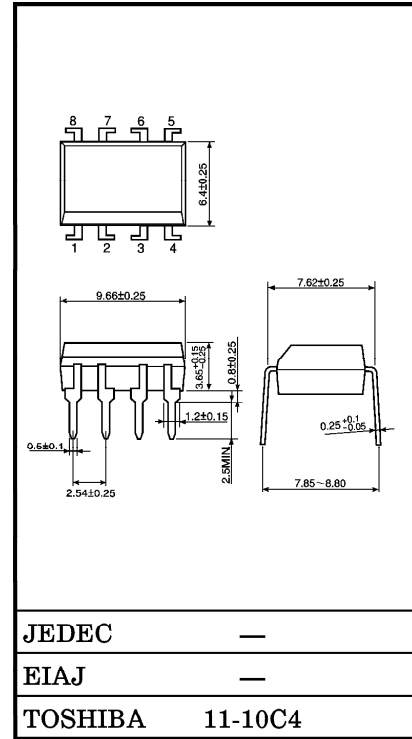

Weight : 0.54g

RECOMMENDED OPERATING CONDITIONS

CHARACTERISTIC	SYMBOL	MIN.	MAX.	UNIT
Input Current, Low Level Each Channel	I_{FL}	0	250	μA
Input Current, High Level Each Channel	I_{FH}	7	20	mA
High Level Enable Voltage	V_{EH}	2.0	V_{CC}	V
Low Level Enable Voltage (Output High)	V_{EL}	0	0.8	V
Supply Voltage, Output	V_{CC}	4.5	5.5	V
Fan Out (TTL LOAD)	N	—	8	—
Operating Temperature	T_a	0	70	°C

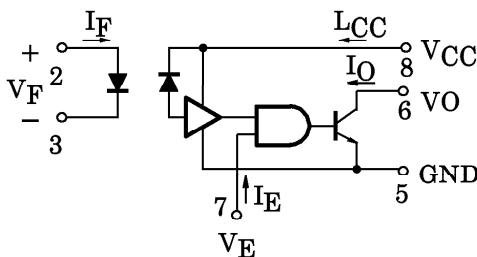

TRUTH TABLE

INPUT	ENABLE	OUTPUT
H	H	L
L	H	H
H	L	H
L	L	H

© The information contained herein is presented only as a guide for the applications of our products. No responsibility is assumed by TOSHIBA CORPORATION for any infringements of intellectual property or other rights of the third parties which may result from its use. No license is granted by implication or otherwise under any intellectual property or other rights of TOSHIBA CORPORATION or others.
 © These TOSHIBA products are intended for use in general commercial applications (office equipment, communication equipment, measuring equipment, domestic appliances, etc.). please make sure that you consult with us before you use these TOSHIBA products in equipment which requires extraordinarily high quality and/or reliability, and in equipment which may involve life threatening or critical application, including but not limited to such uses as atomic energy control, airplane or spaceship instrumentation, traffic signals, medical instrumentation, combustion control, all types of safety devices, etc. TOSHIBA cannot accept and hereby disclaims liability for any damage which may occur in case the TOSHIBA products are used in such equipment or applications without prior consultation with TOSHIBA.

①

(6N137)

MAXIMUM RATINGS

CHARACTERISTIC		SYMBOL	RATING	UNIT
LED	Forward Current	I_F	20	mA
	Pulse Forward Current (Note 1)	I_{FP}	40	mA
	Reverse Voltage	V_R	5	V
DETECTOR	Output Current	I_O	50	mA
	Output Voltage	V_O	7	V
	Supply Voltage (1 minute Maximum)	V_{CC}	7	V
	Enable Input Voltage (Not to exceed V_{CC} by more than 500mV)	V_{EH}	5.5	V
	Output Collector Power Dissipation	P_O	85	mW
Operating Temperature Range		T_{opr}	0~70	°C
Storage Temperature Range		T_{stg}	-55~125	°C
Lead Solder Temperature (10s) (Note 2)		T_{sol}	260	°C

Note 1 : 50% duty cycle, 1ms Pulse width.

Note 2 : Soldering portion of lead : up to 2mm from the body of the device.

PRECAUTION

Please be careful of the followings.

A ceramic capacitor (0.1 μ F) should be connected from pin 8 to pin 5 to stabilize the operation of the high gain linear amplifier. Failure to provide the bypassing may impair the switching property. The total lead length between capacitor and coupler should not exceed 1cm.

(6N137)

ELECTRICAL CHARACTERISTICS
OVER RECOMMENDED TEMPERATURE ($T_a = 0 \sim 70^\circ\text{C}$ Unless otherwise noted)

CHARACTERISTIC	SYMBOL	TEST CONDITION	MIN.	※※TYP.	MAX.	UNIT
High Level Output Current	I_{OH}	$V_{CC} = 5.5\text{V}$, $V_O = 5.5\text{V}$ $I_F = 250\mu\text{A}$, $V_E = 2.0\text{V}$	—	1	250	μA
Low Level Output Voltage	V_{OL}	$V_{CC} = 5.5\text{V}$, $I_F = 5\text{mA}$ $V_{EH} = 2.0\text{V}$ $I_{OL}(\text{Sinking}) = 13\text{mA}$	—	0.4	0.6	V
High Level Enable Current	I_{EH}	$V_{CC} = 5.5\text{V}$, $V_E = 2.0\text{V}$	—	-1.0	—	mA
Low Level Enable Current	I_{EL}	$V_{CC} = 5.5\text{V}$, $V_E = 0.5\text{V}$	—	-1.6	-2.0	mA
High Level Supply Current	I_{CCH}	$V_{CC} = 5.5\text{V}$, $I_F = 0$, $V_E = 0.5\text{V}$	—	7	15	mA
Low Level Supply Current	I_{CCL}	$V_{CC} = 5.5\text{V}$, $I_F = 10\text{mA}$ $V_E = 0.5\text{V}$	—	12	18	mA
Resistance (Input-Output) (Note)	R_{I-O}	$V_{I-O} = 500\text{V}$, $T_a = 25^\circ\text{C}$ $R.H. \leq 60\%$	—	10^{12}	—	Ω
Capacitance (Input-Output) (Note)	C_{I-O}	$f = 1\text{MHz}$, $T_a = 25^\circ\text{C}$	—	0.6	—	pF
Input Forward Voltage	V_F	$I_F = 10\text{mA}$, $T_a = 25^\circ\text{C}$	—	1.65	1.75	V
Input Reverse Breakdown Voltage	BV_R	$I_R = 10\mu\text{A}$, $T_a = 25^\circ\text{C}$	5	—	—	V
Input Capacitance	C_{IN}	$V_F = 0$, $f = 1\text{MHz}$	—	45	—	pF
Current Transfer Ratio	CTR	$I_F = 5.0\text{mA}$, $R_L = 100\Omega$	—	1000	—	%

※※ All typical values are at $V_{CC} = 5\text{V}$, $T_a = 25^\circ\text{C}$

Note : Pins 1, 2, 3 and 4 shorted together and Pins 5, 6, 7 and 8 shorted together.

(6N137)

SWITCHING CHARACTERISTICS (Ta = 25°C, VCC = 5V)

CHARACTERISTIC	SYMBOL	TEST CIRCUIT	TEST CONDITION	MIN.	TYP.	MAX.	UNIT
Propagation Delay Time to High Output Level	t _{pLH}	1	R _L = 350Ω, C _L = 15pF I _F = 7.5mA	—	60	75	ns
Propagation Delay Time to Low Output Level	t _{pHL}	1	R _L = 350Ω, C _L = 15pF I _F = 7.5mA	—	60	75	ns
Output Rise-Fall Time (10-90%)	t _r , t _f	—	R _L = 350Ω, C _L = 15pF I _F = 7.5mA	—	30	—	ns
Propagation Delay Time of Enable from V _{EH} to V _{EL}	t _{ELH}	2	R _L = 350Ω, C _L = 15pF I _F = 7.5mA V _{EH} = 3.0V V _{EL} = 0.5V	—	25	—	ns
Propagation Delay Time of Enable from V _{EL} to V _{EH}	t _{EHL}	2	R _L = 350Ω, C _L = 15pF I _F = 7.5mA V _{EH} = 3.0V V _{EL} = 0.5V	—	25	—	ns
Common Mode Transient Immunity at Logic High Output Level	CM _H	3	V _{CM} = 10V R _L = 350Ω V _O (min.) = 2V I _F = 0mA	—	200	—	V / μs
Common Mode Transient Immunity at Logic Low Output Level	CM _L	3	V _{CM} = 10V R _L = 350Ω V _O (max.) = 0.8V I _F = 5mA	—	-500	—	V / μs

(6N137)

TEST CIRCUIT 1.

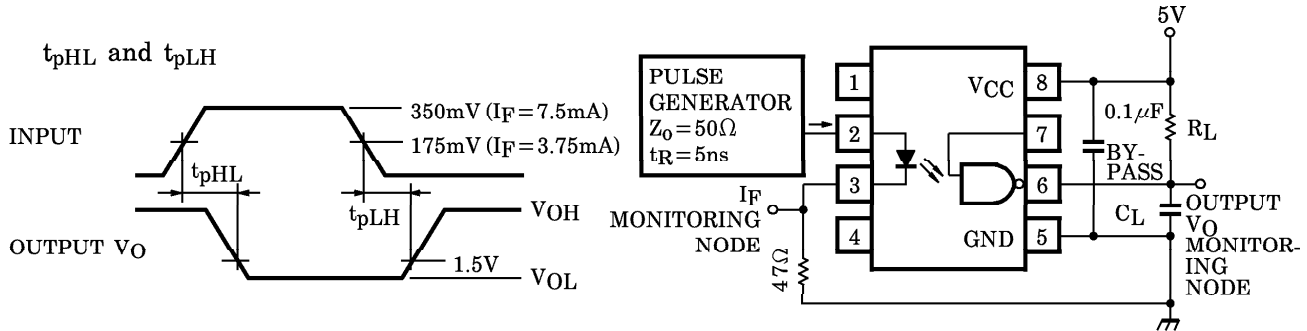

- C_L is approximately 15pF which includes probe and stray wiring capacitance.

TEST CIRCUIT 2.

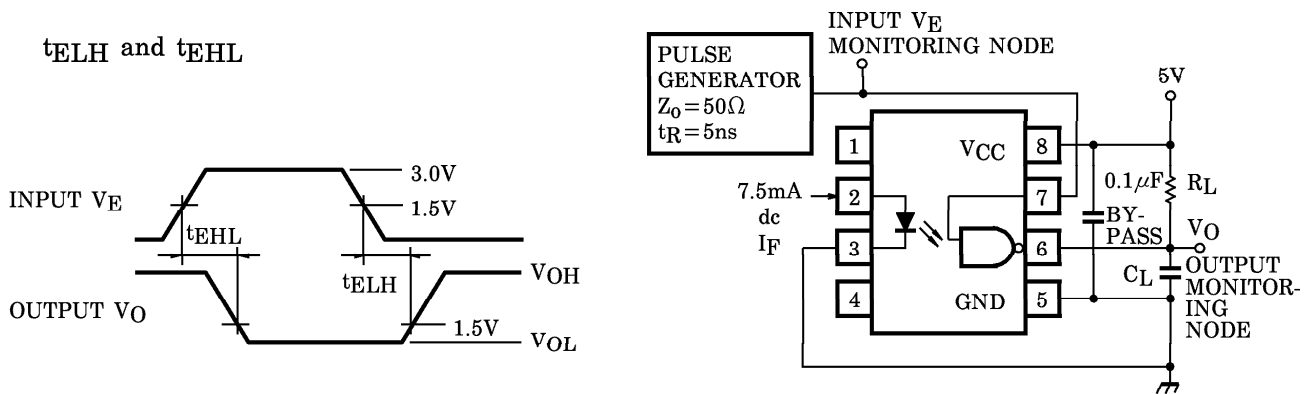

- C_L is approximately 15pF which includes prove and stray wiring capacitance.

TEST CIRCUIT 3.

Transient Immunity and Typical Waveforms

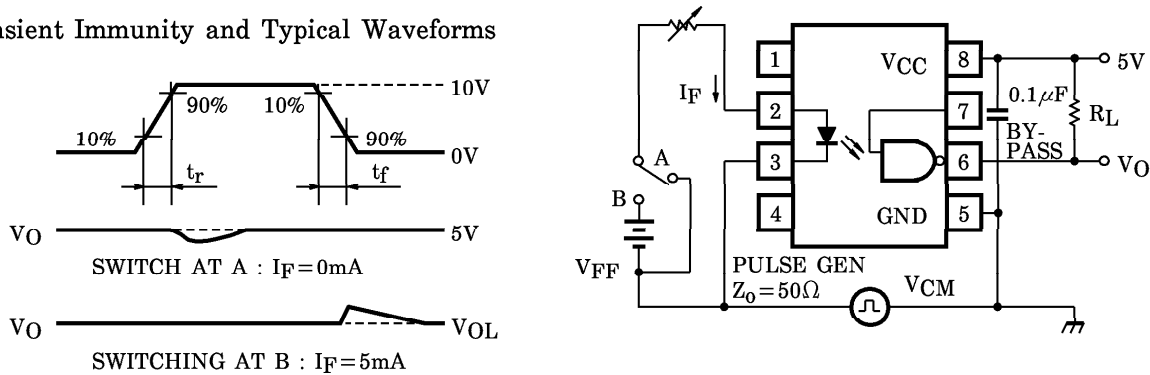

(6N137)

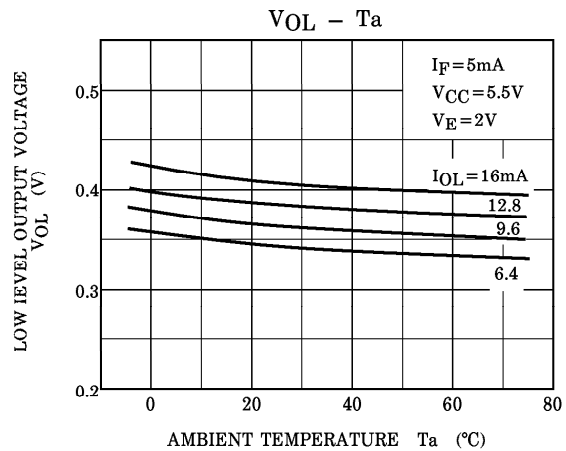
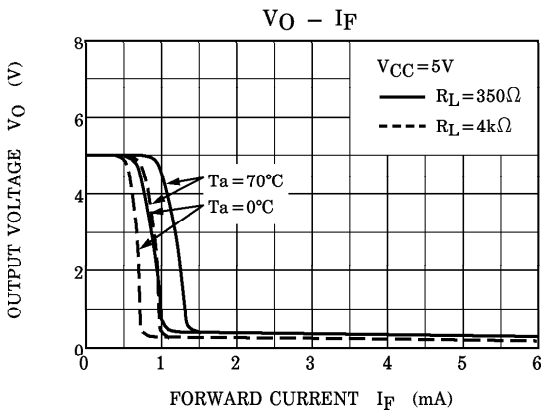
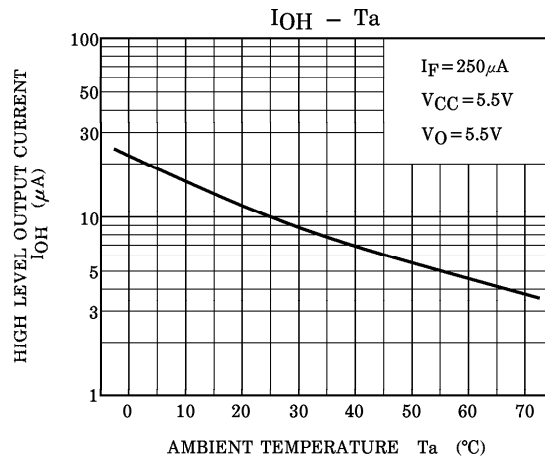
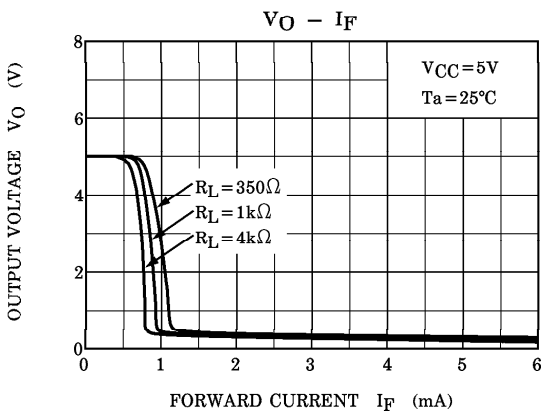
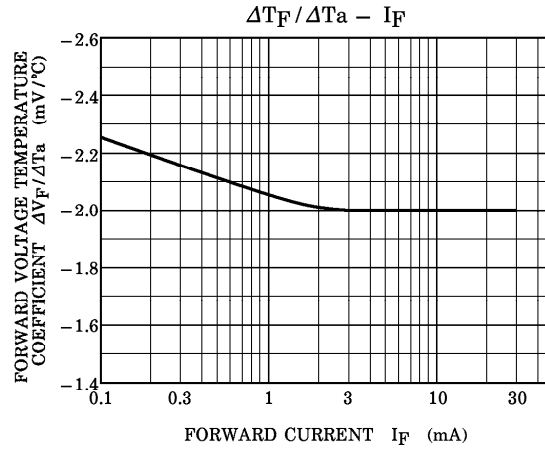
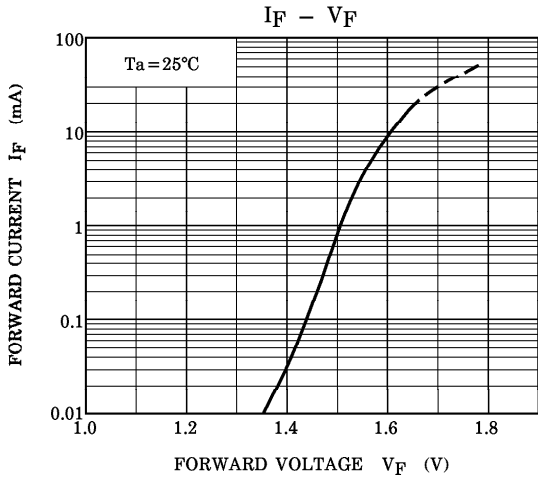

(6N137)

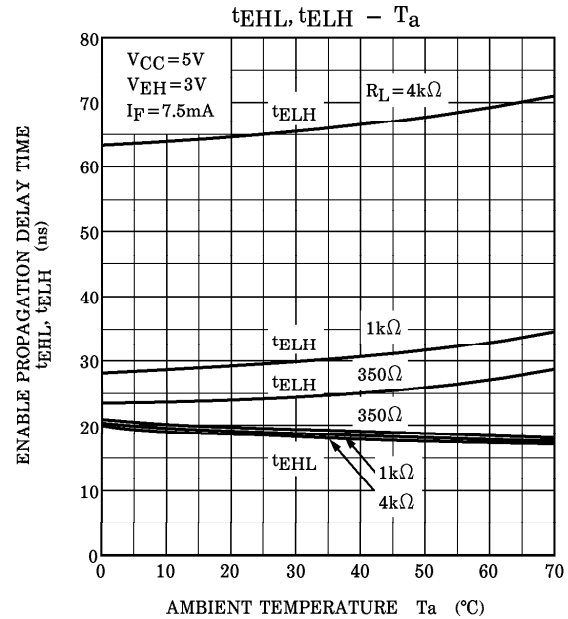
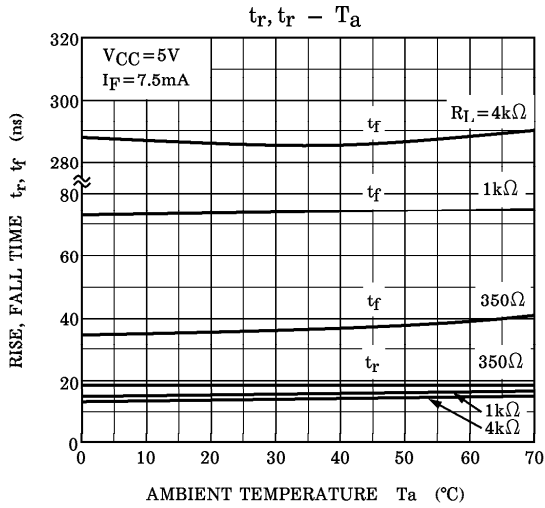
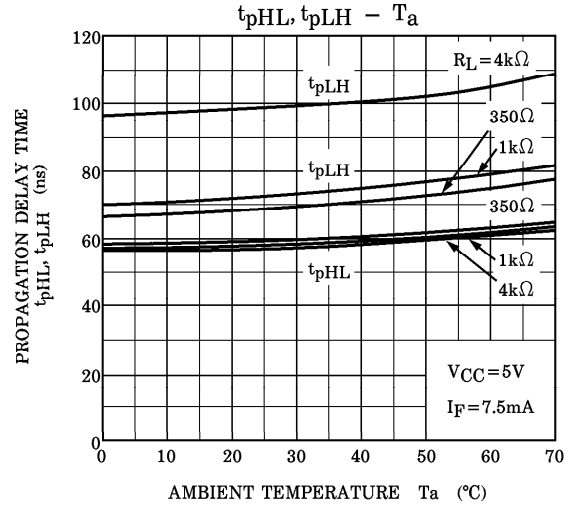
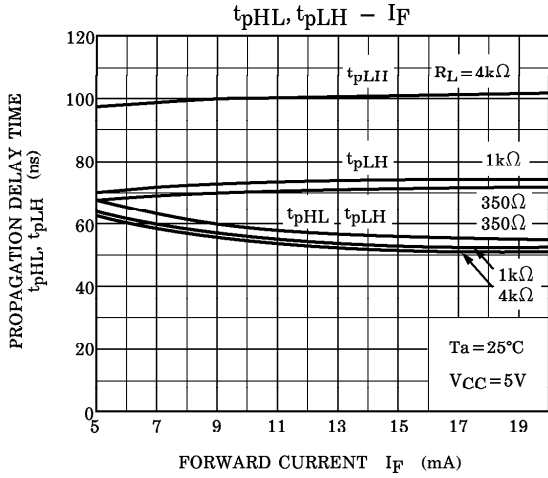

Looking for pricing, stock, or lifecycle information?

Click below to explore more details on WIN SOURCE:

- [View 6N137F on WIN SOURCE](#)
- [Toshiba Semiconductor and Storage Information](#)

Optimize Your Supply Chain with WIN SOURCE Solutions

- ✓ Global Sourcing Solution
- ✓ Obsolete Management
- ✓ Cost Control Management
- ✓ Shortage Management
- ✓ Alternative Solution
- ✓ Excess Inventory Management