



**THE DATASHEET OF
0402X104K100CT**



PSA

PASSIVE SYSTEM ALLIANCE
WALSIN TECHNOLOGY CORPORATION

Multilayer Ceramic Capacitors

www.passivecomponent.com

Product catalog

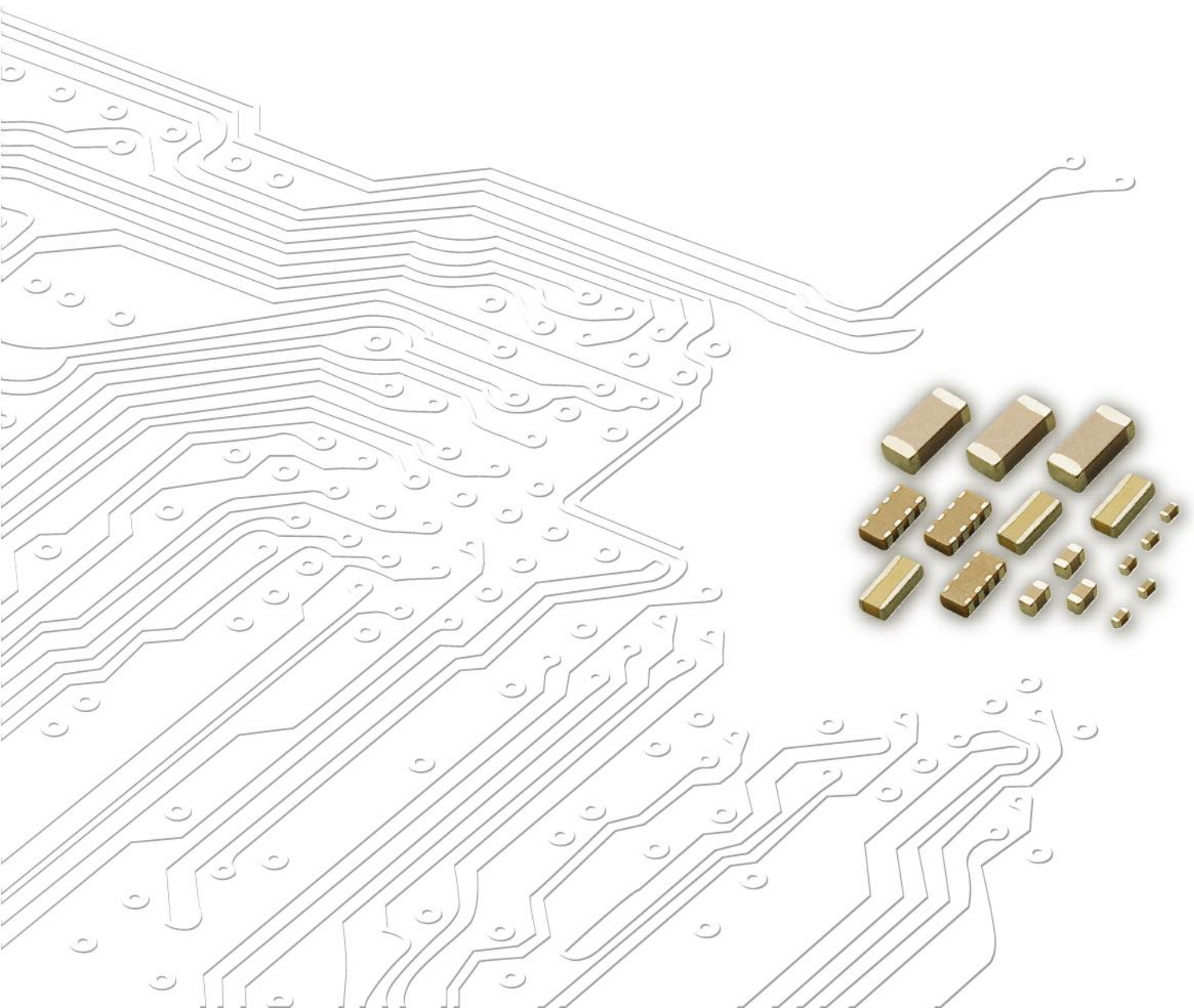

Product Portfolio



Multilayer Ceramic Capacitors



Chip Resistors



Disc Capacitors



Inductors



RF Filters



Antenna

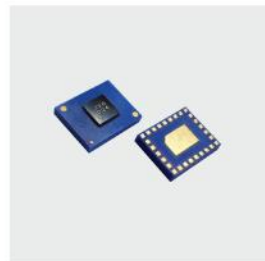

Antenna Switch & Module



MOV Varistors

IEC-63 Nominal Resistance / Capacitance

E1	100																							
E3	100			220			470																	
E6	100	150	220	330	470	680																		
E12	100	120	150	180	220	270	330	390	470	560	680	820												
E24	100	110	120	130	150	160	180	200	220	240	270	300	330	360	390	430	470	510	560	620	680	750	820	910
E96	100	102	121	124	147	150	178	182	215	221	261	267	316	324	383	392	464	475	562	576	681	698	825	845
	105	107	127	130	154	158	187	191	226	232	274	280	332	340	402	412	487	499	590	604	715	732	866	887
	110	113	133	137	162	165	196	200	237	243	287	294	348	357	422	432	511	523	619	634	750	768	909	931
	115	118	140	143	169	174	205	210	249	255	301	309	365	374	442	453	536	549	649	665	787	806	953	976

E6: $\sqrt[6]{10} \approx 1.46$ E12: $\sqrt[12]{10} \approx 1.21$

E1 series resistance: 1Ω, 10Ω, 100Ω, 1000Ω, 10000Ω, 100000Ω

INDEX

Subject	Page
Quick Product Information	1
How To Order and Packaging Dimension/Quantity	2
The Outlines and External Dimensions of Capacitors	3
General Purpose Caps (4V~100V)	4
Ultra-small Caps (01R5 series)	9
Middle & High Voltage Caps (200V~4kV)	10
High Voltage Caps_Surface coating type (2.5kV~4kV)	13
High Q & Low ESR Caps (HH series)	14
Microwave Caps (RF series)	16
Microwave Caps_High Reliability Type (RH series)	18
Soft Termination Capacitors (SH series)	19
High Temperature Caps (HT series)	25
Open-mode Design Caps (OP series)	27
Capacitor Arrays (Y4C2/Y4C3 series)	29
Low Profile Caps (TT series)	30
Low Inductance Caps (0612 series)	31
Safety Certificated Caps X1/Y2 (S2 series)	32
Safety Certificated Caps X2 (S3 series)	33
Automotive Capacitor Qualified to AEC-Q200 (MT series)	34
Automotive Caps without AEC-Q200 Certification (MG series)	36
Automotive Capacitor Arrays Qualified to AEC-Q200 (MY series)	39
Appendix : Reliability Test Conditions and Requirements	40
Appendix : General Information	45

*The specifications are subject to change or our products in it may be discontinued without advance notice. Please check with our sales representatives or product engineers before ordering.

*This catalog has only typical specifications because there is no space for detailed specifications. Therefore, please approve our product specifications or transact the approval sheet for product specifications before ordering.

■ QUICK PRODUCT INFORMATION

Series	Dielectric	Size	Capacitance	Rated voltage	Page
General Purpose Caps (4V~100V)	NPO	0201, 0402, 0603, 0805, 1206, 1210, 1812, 1825, 2220, 2225	0.1pF~0.1μF	10V, 16V, 25V, 50V, 100V	4
	X7R	0201, 0402, 0603, 0805, 1206, 1210, 1812, 1825, 2220, 2225	100pF~47μF	6.3V, 10V, 16V, 25V, 50V, 100V	
	X6S	0201, 0402, 0603, 0805, 1206,1210	0.1μF~100μF	6.3V, 10V, 16V, 25V	
	X7S	0402, 0603, 0805, 1206,1210	1.0μF~100μF	6.3V, 10V, 16V, 25V, 50V, 100V	
	X5R	0201, 0402, 0603, 0805, 1206,1210	100pF~220μF	4V, 6.3V, 10V, 16V, 25V, 50V	
	Y5V	0402, 0603, 0805, 1206, 1210, 1812	0.01μF~100μF	6.3V, 10V, 16V, 25V, 50V, 100V	
Ultra-small Caps (01R5 series)	NPO	01005	0.2pF~100pF	10V, 25V, 50V	9
	X7R	01005	100pF~1000pF	10V	
	X5R	01005	1000pF~0.033μF	6.3V,10V	
Middle & High Voltage Caps (200V~4kV)	NPO	0402, 0603, 0805, 1206, 1210, 1808, 1812, 1825, 2220, 2225	0.5pF~0.1μF	200V, 250V, 500V, 630V, 1kV, 2kV, 3kV, 4kV	10
	X7R	0603, 0805, 1206, 1210, 1808, 1812, 1825, 2220, 2225	100pF~2.2μF	200V, 250V, 400V, 450V, 500V, 630V, 1kV, 2kV, 3kV, 4kV	
	Y5V	0805, 1206, 1210, 1812	0.01μF~0.68μF	200V, 250V	
High Voltage Caps (Surface Coating Type)	X7R	1206, 1210, 1808, 1812, 1825, 2220, 2225	150pF~0.018μF	2.5kV, 3kV, 4kV	13
High Q & Low ESR Caps (HH series)	NPO	0201,0402, 0603,0805	0.3pF to 3300pF	10V, 16V, 25V, 50V, 100V, 200V, 250V, 500V, 630V	14
Microwave Caps (RF series)	NPO	01005, 0201, 0402, 0603, 0805, 0505, 1111	0.1pF~1000pF	6.3V, 10V, 25V, 50V, 100V, 250V, 500V, 1500V	16
Microwave Caps_High Reliability Type (RH series)	NPO	0402, 0603, 0805, 0505	0.1pF~10pF	200V,250V	18
Soft Termination Capacitors (SH series)	NPO	0402, 0603, 0805,1206, 1210, 1808, 1812,1825,2220,2225	0.5pF~0.1μF	10V, 16V, 25V, 50V, 100V, 200V, 250V, 500V, 630V, 1kV, 3kV	19
	X7R	0402, 0603, 0805,1206, 1210, 1808, 1812,1825,2220,2225	100pF~22μF	10V, 16V, 25V, 50V, 100V,200V, 250V, 500V, 630V, 1kV, 2kV, 3kV	
High Temperature Caps (HT series)	X8G	0402,0603, 0805,1206, 1210	0.2pF~0.015μF	10V, 16V, 25V, 50V, 100V	25
	X8R	0402, 0603, 0805	100pF~0.047μF	10V, 16V, 25V, 50V	
Open-mode Design Caps (OP series)	X7R	0805, 1206, 1210, 1812	100pF~1μF	100V, 200V, 250V, 500V	27
Capacitor Arrays (Y4C2/Y4C3 series)	NPO	0508 (4x0402), 0612 (4x0603)	10pF~470pF	25V, 50V,100V	29
	X7R	0508 (4x0402), 0612 (4x0603)	180pF~0.1μF	10V, 16V, 25V, 50V	
	Y5V	0612 (4x0603)	0.01μF~0.1μF	16V, 50V	
Low Profile Caps (TT series)	X7R	0805, 1206, 1210	1.0μF~10μF	10V, 16V, 25V, 50V,100V,	30
	X5R	0402, 0603, 0805, 1206, 1210	0.22μF~47μF	6.3V, 10V, 16V, 25V	
	Y5V	0805, 1206, 1210	2.2μF~10μF	10V, 16V, 25V, 50V	
Low Inductance Caps (0612 series)	X7R	0612	0.01μF~0.15μF	50V	31
Safety Certificated Caps X1/Y2 (S2 series)	NPO	1808, 1812, 2211	3pF~720pF	250Vac	32
	X7R	1808, 1812, 2220, 2211	100pF~4700pF	250Vac	
Safety Certificated Caps X2 (S3 series)	NPO	1808, 1812	3pF~1000pF	250Vac	33
	X7R	1808, 1812, 2220	150pF~0.022μF	250Vac	
Automotive Capacitor Qualified to AEC-Q200 (MT series)	NPO	0201, 0402, 0603, 0805, 1206, 1210	0.1pF~0.015μF	10V, 16V, 25V, 50V, 100V, 250V, 500V, 630V, 1kV	34
	X7R	0201, 0402, 0603, 0805, 1206, 1210	100pF~2.2μF	10V, 16V, 25V, 50V, 100V, 250V, 500V, 630V, 1kV	
Automotive Caps Without AEC-Q200 Certification (MG series)	NPO	0201, 0402, 0603, 0805, 1206, 1210, 1812	0.1pF~0.033μF	10V, 16V, 25V, 50V, 100V, 250V, 500V, 630V, 1kV	36
	X7R	0201, 0402, 0603, 0805, 1206, 1210, 1812	100pF~2.2μF	10V, 16V, 25V, 50V, 100V, 250V, 500V, 630V, 1kV	
	X5R	0402, 0603, 0805, 1206, 1210	0.056μF~10μF	6.3V,10V,16V,25V	
Automotive Capacitor Arrays Qualified AEC-Q200 (MY Series)	NPO	0612(4x0603), 0508(4x0402)	10pF~470pF	16V, 25V, 50V, 100V	39
	X7R	0612(4x0603), 0508(4x0402)	470pF~0.1μF	10V, 16V, 25V, 50V	

■ HOW TO ORDER

Type of MLCC	0805		B	104	K	500	C	T
General Purpose MLCC Ultra-small MLCC Middle & High Voltage MLCC	Size Inch (mm) : 01R5(0402), 0201(0603), 0402(1005), 0603(1608), 0805(2012), 1206(3216), 1210(3225), 1808(4520), 1812(4532), 1825(4563), 2220(5750), 2225(5763)		Dielectric N=NP0 G=X8G R=X8R B=X7R A=X7S S=X6S X=X5R F=Y5V	Capacitance Two significant digits followed by no. of zeros. And R is in place of decimal point. R47=0.47pF 0R5=0.5pF 1R0=1pF 100=10pF 101=100pF 102=1000pF 103=0.01uF 104=0.1uF 105=1uF 106=10uF 107=100uF	Tolerance A= ±0.05pF B= ±0.1pF C= ±0.25pF D= ±0.5pF F= ±1% G= ±2% J= ±5% K= ±10% M= ±20% Z=-20/+80% P=±0.02pF** Q=±0.03pF**	Rated voltage Two significant digits followed by no. of zeros. And R is in place of decimal point. 4R0=4 Vdc 6R3=6.3 Vdc 100=10 Vdc 160=16 Vdc 250=25 Vdc 350=35 Vdc 500=50 Vdc 101=100 Vdc 201=200 Vdc 251=250 Vdc 401=400 Vdc 451=450 Vdc 501=500 Vdc 631=630 Vdc 102=1k Vdc 152=1.5k Vdc 202=2k Vdc 252=2.5k Vdc 302=3k Vdc 402=4k Vdc 502=5k Vdc 602=6k Vdc	Termination C=Cu/Ni/Sn M= Cu/Ni/Sn Surface coating C=Cu/Ni/Sn SH: C=Ag polymer/ Ni/Sn C=Cu/Ni/Sn	Packaging T=7" reeled Q=10" reeled G=13" reeled
High Vol. Cap. with Surface Coating	0612 (1632)							
Low Inductance MLCC	RF	03						
High Q / Low ESR MLCC Microwave MLCC RF Cap. with High reliability High Temperature MLCC. Low Profile MLCC Open Mode MLCC Safety Certificated MLCC Automotive MLCC	Series HH=High Q/ Low ESR RF=Microwave UF=Ultra-Microwave RH=RF Cap. with High reliability HT=High Temperature Cap TT=Low profile OP=Open-mode design S2=X1/Y2 safety class S3=X2 safety class MG=Automotive Cap. without AEC-Q200 MT=Automotive Cap. with AEC-Q200 MY=Automotive Array with AEC-Q200		Size Inch : 02=01005 03=0201 15=0402 11=0505 18=0603 21=0805 22=1111 31=1206 32=1210 42=1808 43=1812 52=2211 55=2220 56=2225					
	Soft Termination MLCC		SH=With Ag polymer					
Cap Arrays MLCC	Y	4 C	3					
	Type Y=Capacitor array	Cap. Nr. 4C=4xCap	Termination pitch 3=0.03 inch 2=0.02 inch					

* The packaging code per each size of reel, please refer to following table "packaging style and quantity".

** Tolerance "P" & "Q" only for UF series items.

■ PACKAGING STYLE AND QUANTITY

Unit: pieces

Size Inch (mm)	Thickness (mm)/Symbol		Paper tape		Plastic tape	
			7" reel	13" reel	7" reel	13" reel
01005 (0402)	0.20±0.02	V	20,000	-	40,000(W4P1)-	-
0201 (0603)	0.30±0.03	L	15,000	70,000	-	-
0402 (1005)	0.50±0.05	N	10,000	50,000	-	-
	0.50+0.02/-0.05	Q	10,000	50,000	-	-
0603 (1608)	0.50±0.20	E	10,000	-	-	-
	0.50±0.10	H	4,000	-	-	-
	0.80±0.07	S	4,000	15,000	-	-
0805 (2012)	0.80+0.15/-0.10	X	4,000	15,000	-	-
	0.50±0.10	H	4,000	15,000	-	-
	0.60±0.10	A	4,000	15,000	-	-
	0.80±0.10	B	4,000	15,000	-	-
	0.85±0.10	T	4,000	15,000	-	-
1206 (3216)	1.25±0.10	D	-	-	3,000	10,000
	1.25±0.20	I	-	-	3,000	10,000
	0.80±0.10	B	4,000	15,000	-	-
	0.85±0.10	T	4,000	15,000	-	-
	0.95±0.10	C	-	-	3,000	10,000
	1.15±0.15	J	-	-	3,000	10,000
	1.25±0.10	D	-	-	3,000	10,000
1210 (3225)	1.60±0.20	G	-	-	2,000	-
	1.60+0.30/-0.10	P	-	-	2,000	9,000
	0.85±0.10	T	-	-	3,000	10,000
	0.95±0.10	C	-	-	3,000	10,000
	1.25±0.10	D	-	-	3,000	10,000
	1.60±0.20	G	-	-	2,000	-
1808 (4520)	2.00±0.20	K	-	-	1,000	6,000
	2.50±0.30	M	-	-	1,000	6,000
	1.25±0.10	D	-	-	2,000	10,000
	1.10±0.15	F	-	-	2,000	10,000
	1.60±0.20	G	-	-	2,000	8,000
1812 (4532)	2.00±0.20	K	-	-	1,000	6,000
	1.25±0.10	D	-	-	1,000	5,000
	1.60±0.20	G	-	-	1,000	-
	2.00±0.20	K	-	-	1,000	-
	2.50±0.30	M	-	-	500	3,000
1825 (4563) 2220 (5750) 2225 (5763)	2.80±0.30	U	-	-	500	-
	1.60±0.20	G	-	-	1,000	-
	2.00±0.20	K	-	-	1,000	-
	2.50±0.30	M	-	-	500	-
0505 (1414)	1.15±0.15	J	-	-	3,000	-
1111 (2828)	≤ 1.78	G	-	-	2,000	-

■ SINGLE CHIP CAPACITORS

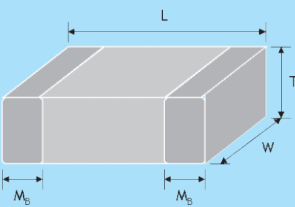
Outline	Size Inch (mm)	L (mm)	W (mm)	T (mm)/Symbol	Soldering Method *	M _B (mm)	
	01R5 (0402)	0.4±0.02	0.2±0.02	0.2±0.02	V	R	0.10±0.03
	0201 (0603)	0.6±0.03	0.3±0.03	0.3±0.03	L	R	0.15±0.05
		0.6±0.05 ^{#2}	0.3±0.05 ^{#2}	0.3±0.05 ^{#2}			0.15±0.1/-0.05
	0402 (1005)	1.00±0.05	0.50±0.05	0.50±0.05	N	R	0.25 +0.05/-0.10
		1.00±0.20	0.50±0.20	0.50±0.20	E	R	
	0603 (1608)	1.60±0.10	0.80±0.10	0.80±0.07	S	R / W	0.40±0.15
		1.60+0.15/-0.10	0.80+0.15/-0.10	0.50±0.10	H	R / W	
				0.80+0.15/-0.10	X	R / W	
	0805 (2012)	2.00±0.15	1.25±0.10	0.50±0.10	H	R / W	0.50±0.20
				0.60±0.10	A	R / W	
				0.80±0.10	B	R / W	
		1.25±0.10	D	R			
		2.00±0.20	1.25±0.20	0.85±0.10	T	R / W	
	1.25±0.20			I	R		
	1206 (3216)	3.20±0.15	1.60±0.15	0.80±0.10	B	R / W	0.60±0.20 (0.5±0.25) ^{***}
				0.95±0.10	C	R	
		1.25±0.10	D	R			
		1.15±0.15	J	R			
		1.60±0.20	G	R			
		0.85±0.10	T	R / W			
3.20 +0.30/-0.10	1.60 +0.30/-0.10	1.60+0.30/-0.10	P	R			
1210 (3225)	3.20±0.30	2.50±0.20	0.95±0.10	C	R	0.75±0.25	
			0.85±0.10	T	R		
	1.25±0.10	D	R				
	1.60±0.20	G	R				
	2.00±0.20	K	R				
3.20±0.60 ^{#4}	2.50±0.50 ^{#4}	2.50±0.50 ^{#4}	M	R			
1808 (4520)	4.50±0.40 (4.5+0.5/-0.3) ^{**}	2.03±0.25	1.25±0.10	D	R	0.75±0.25 (0.5±0.25) ^{***}	
			1.40±0.15	F	R		
			1.60±0.20	G	R		
			2.00±0.20	K	R		
1812 (4532)	4.50±0.40 (4.5+0.5/-0.3) ^{**}	3.20±0.30	1.25±0.10	D	R	0.75±0.25 (0.5±0.25) ^{***}	
			1.60±0.20	G	R		
		2.00±0.20	K	R			
		3.20±0.40	2.50±0.30	M	R		
			2.80±0.30	U	R		
1825 (4563)	4.50±0.40	6.30±0.40	1.60±0.20 (G)	R	0.75±0.35		
2211 (5728)	5.70±0.40	2.80±0.30	2.00±0.20 (K)	R	0.85±0.35		
2220 (5750)	5.70±0.40	5.00±0.40	2.50±0.30 (M)	R	0.85±0.35		
2225 (5763)	5.70±0.40	6.30±0.40	2.80±0.30 (U)	R	0.85±0.35		

* R = Reflow soldering process; W = Wave soldering process.

** For 1808/1812/1825_200V~4000V and safety certificated products.

*** For 1206 ≥ 1000V, 1808/1812_200V~4000V and safety certificated products.

#1: For 0603/Cap ≥ 10µF or 0603(≤ 6.3V)/Cap ≥ 4.7µF or 0603(>10V)/Cap > 1µF products.

#2: For 0201/ 0.1µF < Cap < 0.68µF products.

#3: For 0201/Cap ≥ 0.68µF products.

#4: For 1210(100V)/Cap > 1µF or 1210(250V)/Cap > 0.47µF or 1210(400V~630V)/Cap > 0.22µF.

The table only for General Purpose Series, Soft termination and others please refer to individual sheet for details.

■ Capacitor Arrays

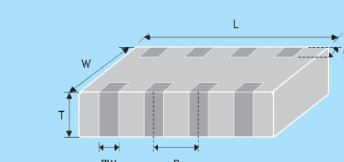
Outline	Size Inch (mm)	L (mm)	W (mm)	T (mm)/Symbol	S (mm)	BW (mm)	P (mm)
	0603 x 4 (0612 (1632))	3.20±0.15	1.60±0.15	0.80±0.10	B	0.30±0.20	0.40±0.15
	0402 x 4 (0508 (1220))	2.00±0.15	1.25±0.15	0.85±0.10	T	0.20±0.10	0.25±0.10

Reflow soldering process only.

■ Low Inductance Capacitors

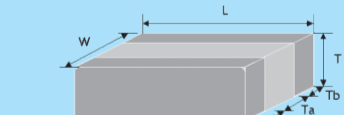
Outline	Size Inch (mm)	L (mm)	W (mm)	T (mm)/Symbol	T _a min. (mm)	T _b min. (mm)
	0612 (1632)	3.20±0.15	1.60±0.15	0.80±0.10	B	0.5
						0.13

Reflow soldering process only.

■ **FEATURES**

- * A wide selection of sizes is available (0201 to 2225).
- * High capacitance in given case size.
- * Capacitor with lead-free termination (pure Tin).

■ **GENERAL ELECTRICAL DATA**

Dielectric	NP0	X7R	X7S	X6S	X5R	Y5V
Size	0201, 0402, 0603, 0805, 1206, 1210, 1812, 1825, 2220, 2225					
Capacitance range	0.1pF to 0.1μF	100pF to 47μF	1μF to 100μF	0.1μF to 100μF	100pF to 220μF	0.01μF to 100μF
Capacitance tolerance	Cap≤5pF ^{#1} : A (±0.05pF), B (±0.1pF), C (±0.25pF) 5pF<Cap<10pF: C (±0.25pF), D (±0.5pF) Cap≥10pF: F(±1%), G (±2%), J (±5%), K (±10%)	J (±5%), K (±10%), M (±20%)	K (±10%), M (±20%)	K (±10%), M (±20%)	K (±10%), M (±20%)	M (±20%), Z (-20/+80%)
Rated voltage (WVDC)	10V, 16V, 25V, 50V, 100V	4V, 6.3V, 10V, 16V, 25V, 50V, 100V				
Operating temperature	-55 to +125°C			-55 to +105°C	-55 to +85°C	-25 to +85°C
Capacitance characteristic	±30ppm	±15%	±22%		±15%	+30/-80%
Termination	Ni/Sn (lead-free termination)					

#1: NP0, 0.1pF product only provide B tolerance

■ **EXPLANATION OF PART NUMBERS**

1206	E	104	Z	500	C	I
<u>Size (Inch (mm))</u> 1206 (3216)	<u>Dielectric</u> F=Y5V	<u>Capacitance</u> 104=10x10 ⁴ =100nF	<u>Tolerance</u> Z=-20/+80%	<u>Rated voltage</u> 500=50 VDC	<u>Termination</u> C=Cu/Ni/Sn	<u>Packaging style</u> T=7" reeled

Please refer to page 2 "How to order" for more information.

■ **ELECTRICAL CHARACTERISTICS**

1) Frequency characteristics

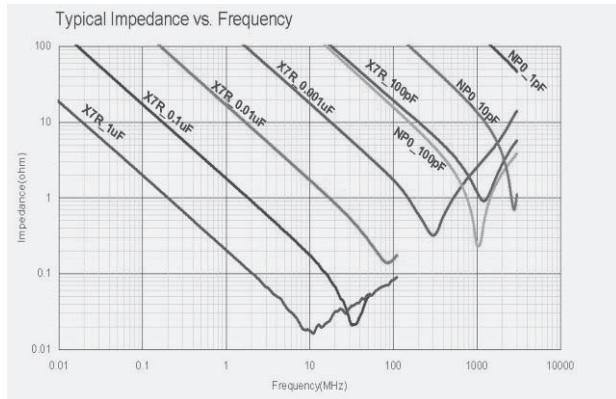

2) Capacitance Change - Typical aging rate

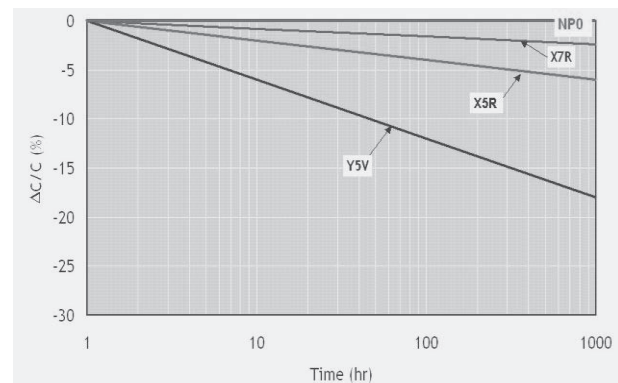

3) Temperature characteristics of capacitance (TCC)

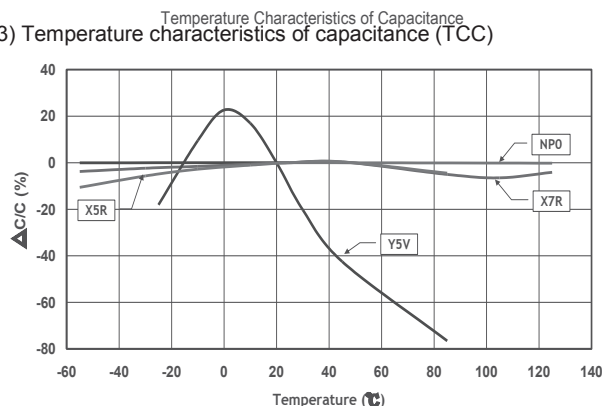

4) DC Bias characteristics DC bias Characteristics

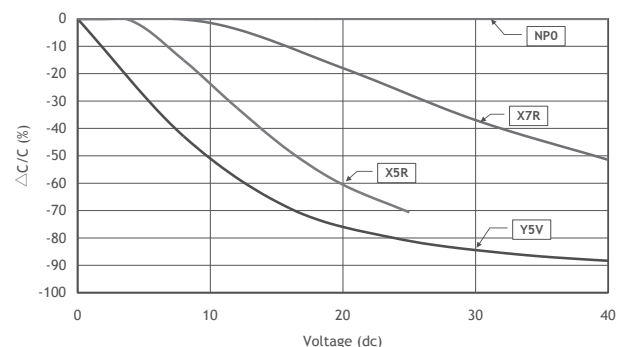

All above typical electronic characteristics are for reference only.
Please contact with Walsin representative for detail information of any specific item.

■ CAPACITANCE RANGE

NP0 Dielectric

Dielectric		NP0																						
Size		0201		0402		0603		0805			1206			1210			1812		1825		2220		2225	
Rated Voltage (VDC)		16	50	10	100	10	100	10	25	100	10	25	100	10	25	100	10	100	50	100	50	100	50	100
		25		25	50	25	50	16	50		16	50		16	50		16	50	100	100	50	100	50	100
Capacitance	0.3pF (0R3)	L	L	N		S																		
	0.4pF (0R4)	L	L	N		S																		
	0.5pF (0R5)	L	L	N	N	S	S	A	A	A														
	0.6pF (0R6)	L	L	N	N	S	S	A	A	A														
	0.7pF (0R7)	L	L	N	N	S	S	A	A	A														
	0.8pF (0R8)	L	L	N	N	S	S	A	A	A														
	0.9pF (0R9)	L	L	N	N	S	S	A	A	A														
	1.0pF (1R0)	L	L	N	N	S	S	A	A	A														
	1.2pF (1R2)	L	L	N	N	S	S	A	A	A	B	B	B											
	1.5pF (1R5)	L	L	N	N	S	S	A	A	A	B	B	B											
	1.8pF (1R8)	L	L	N	N	S	S	A	A	A	B	B	B											
	2.0pF (2R0)	L	L	N	N	S	S	A	A	A	B	B	B											
	2.2pF (2R2)	L	L	N	N	S	S	A	A	A	B	B	B											
	2.7pF (2R7)	L	L	N	N	S	S	A	A	A	B	B	B											
	3.0pF (3R0)	L	L	N	N	S	S	A	A	A	B	B	B											
	3.3pF (3R3)	L	L	N	N	S	S	A	A	A	B	B	B											
	3.9pF (3R9)	L	L	N	N	S	S	A	A	A	B	B	B											
	4.0pF (4R0)	L	L	N	N	S	S	A	A	A	B	B	B											
	4.7pF (4R7)	L	L	N	N	S	S	A	A	A	B	B	B											
	5.0pF (5R0)	L	L	N	N	S	S	A	A	A	B	B	B											
	5.6pF (5R6)	L	L	N	N	S	S	A	A	A	B	B	B											
	6.0pF (6R0)	L	L	N	N	S	S	A	A	A	B	B	B											
	6.8pF (6R8)	L	L	N	N	S	S	A	A	A	B	B	B											
	7.0pF (7R0)	L	L	N	N	S	S	A	A	A	B	B	B											
	8.0pF (8R0)	L	L	N	N	S	S	A	A	A	B	B	B											
	8.2pF (8R2)	L	L	N	N	S	S	A	A	A	B	B	B											
	9.0pF (9R0)	L	L	N	N	S	S	A	A	A	B	B	B											
	10pF (100)	L	L	N	N	S	S	A	A	A	B	B	B	C	C	C	D	D	G	G	G	G	G	G
	12pF (120)	L	L	N	N	S	S	A	A	A	B	B	B	C	C	C	D	D	G	G	G	G	G	G
	15pF (150)	L	L	N	N	S	S	A	A	A	B	B	B	C	C	C	D	D	G	G	G	G	G	G
	18pF (180)	L	L	N	N	S	S	A	A	A	B	B	B	C	C	C	D	D	G	G	G	G	G	G
	22pF (220)	L	L	N	N	S	S	A	A	A	B	B	B	C	C	C	D	D	G	G	G	G	G	G
	27pF (270)	L	L	N	N	S	S	A	A	A	B	B	B	C	C	C	D	D	G	G	G	G	G	G
	33pF (330)	L	L	N	N	S	S	A	A	A	B	B	B	C	C	C	D	D	G	G	G	G	G	G
	39pF (390)	L	L	N	N	S	S	A	A	A	B	B	B	C	C	C	D	D	G	G	G	G	G	G
	47pF (470)	L	L	N	N	S	S	A	A	A	B	B	B	C	C	C	D	D	G	G	G	G	G	G
	56pF (560)	L	L	N	N	S	S	A	A	A	B	B	B	C	C	C	D	D	G	G	G	G	G	G
	68pF (680)	L	L	N	N	S	S	A	A	A	B	B	B	C	C	C	D	D	G	G	G	G	G	G
	82pF (820)	L	L	N	N	S	S	A	A	A	B	B	B	C	C	C	D	D	G	G	G	G	G	G
	100pF (101)	L	L	N	N	S	S	A	A	A	B	B	B	C	C	C	D	D	G	G	G	G	G	G
	120pF (121)	L	L	N	N	S	S	A	A	A	B	B	B	C	C	C	D	D	G	G	G	G	G	G
	150pF (151)	L	L	N	N	S	S	A	A	A	B	B	B	C	C	C	D	D	G	G	G	G	G	G
	180pF (181)			N	N	S	S	A	A	A	B	B	B	C	C	C	D	D	G	G	G	G	G	G
	220pF (221)			N	N	S	S	A	A	A	B	B	B	C	C	C	D	D	G	G	G	G	G	G
	270pF (271)	L		N		S	S	A	A	A	B	B	B	C	C	C	D	D	G	G	G	G	G	G
	330pF (331)	L		N		S	S	A	A	A	B	B	B	C	C	C	D	D	G	G	G	G	G	G
	390pF (391)	L		N		S	S	B	B	B	B	B	B	C	C	C	D	D	G	G	G	G	G	G
	470pF (471)	L		N		S	S	B	B	B	B	B	B	C	C	C	D	D	G	G	G	G	G	G
	560pF (561)	L		N		S	S	B	B	B	B	B	B	C	C	C	D	D	G	G	G	G	G	G
	680pF (681)			N		S	S	B	B	B	B	B	B	C	C	C	D	D	G	G	G	G	G	G
820pF (821)			N		S	S	B	B	B	B	B	B	C	C	C	D	D	G	G	G	G	G	G	
1,000pF (102)			N		S	S	B	B	B	B	B	B	C	C	C	D	D	G	G	G	G	G	G	
1,200pF (122)					X	X	B	B	B	B	B	B	C	C	C	D	D	G	G	G	G	G	G	
1,500pF (152)					X	X	B	B	B	B	B	B	C	C	C	D	D	G	G	G	G	G	G	
1,800pF (182)					X		B	B	B	B	B	B	C	C	C	D	D	G	G	G	G	G	G	
2,200pF (222)					X		B	B	B	B	B	B	C	C	C	D	D	G	G	G	G	G	G	
2,700pF (272)					X		D	D	D	B	B	B	C	C	C	D	D	G	G	G	G	G	G	
3,300pF (332)					X		D	D	D	B	B	B	C	C	C	D	D	G	G	G	G	G	G	
3,900pF (392)					X		D	D	D	B	B	B	C	C	C	D	D	G	G	G	G	G	G	
4,700pF (472)					X		D	D	D	B	B	B	C	C	C	D	D	G	G	G	G	G	G	
5,600pF (562)					X		D	D	D	B	B	B	C	C	C	D	D	G	G	G	G	G	G	
6,800pF (682)					X		D	D	D	C	C	C	C	C	C	D	D	G	G	G	G	G	G	
8,200pF (822)					X		D	D	D	D	D	D	C	C	C	D	D	G	G	G	G	G	G	
0.010uF (103)					X		D	D	D	D	D	D	C	C	C	D	D	G	G	G	G	G	G	
0.012uF (123)							T	T		P	P	P	D	D	D	D	D	G	G	G	G	G	G	
0.015uF (153)							T	T		P	P	P	D	D	D	D	D	G	G	G	G	G	G	
0.018uF (183)							D	D		P	P	P	K	K	K	D	D	G	G	G	G	G	G	
0.022uF (223)							D	D		P	P	P	K	K	K	D	D	G	G	G	G	G	G	
0.027uF (273)										P	P	P	K	K	K	D	D	G	G	G	G	G	G	
0.033uF (333)										P	P	T	K	K	K	D	D	G	G	G	G	G	G	
0.039uF (393)										P	P		K	K	K	M	M	G	G	G	G	G	G	
0.047uF (473)										J	J		K	K	K	M	M	G	G	G	G	G	G	
0.056uF (563)										J	J					M	M	G	K	G	K	G	G	
0.068uF (683)										G	G					M	M	G	K	K	K	G	K	
0.082uF (823)										G	G					M	M	K	M	M	M	K	K	
0.10uF (104)										G	G					M	M	M	M	M	M	K	M	
0.12uF (124)																								
0.15uF (154)																								
0.18uF (184)																								
0.22uF (224)																								
0.27uF (274)																								

1. The letter in cell is expressed the symbol of product thickness.
2. For more information about products with special capacitance or other data, please contact WTC local representative.

Y5V Dielectric (0402, 0603, 0805 Size)

Dielectric		Y5V															
Size		0402					0603					0805					
Rated Voltage (VDC)		6.3	10	16	25	50	6.3	10	16	25	50	6.3	10	16	25	50	100
Capacitance	0.010uF (103)		N	N	N	N		S	S	S	S		A	A	A	A	B
	0.015uF (153)		N	N	N	N		S	S	S	S		A	A	A	A	B
	0.022uF (223)		N	N	N	N		S	S	S	S		A	A	A	A	B
	0.033uF (333)		N	N	N	N		S	S	S	S		A	A	A	A	B
	0.047uF (473)		N	N	N			S	S	S	S		A	A	A	A	B
	0.068uF (683)		N	N	N			S	S	S	S		A	A	A	A	B
	0.10uF (104)		N	N	N			S	S	S	S		A	A	A	A	B
	0.15uF (154)		N					S	S	S	S		A	A	A	A	
	0.22uF (224)	N	N					S	S	S	S		A	A	A	A	
	0.33uF (334)	N	N					S	S	S			B	B	B	B	
	0.47uF (474)	N	N					S	S	X			B	B	B	B/D	
	0.68uF (684)							S	X				B	B	D	D	
	1.0uF (105)	N / E	N / E					S	X				B	B	D	D	
	1.5uF (155)							S					D	D			
	2.2uF (225)							S	S				D	D			
	3.3uF (335)												D	D			
	4.7uF (475)												D	D			
	6.8uF (685)												I				
10uF (106)												I	I				
22uF (226)																	

Y5V Dielectric (1206, 1210, 1812 Size)

Dielectric		Y5V																		
Size		1206						1210						1812						
Rated Voltage (VDC)		6.3	10	16	25	35	50	100	6.3	10	16	25	35	50	100	10	16	25	50	100
Capacitance	0.010uF (103)		B	B	B		B	B							C					D
	0.015uF (153)		B	B	B		B	B							C					D
	0.022uF (223)		B	B	B		B	B							C					D
	0.033uF (333)		B	B	B		B	B							C					D
	0.047uF (473)		B	B	B		B	B							C					D
	0.068uF (683)		B	B	B		B	B							C					D
	0.10uF (104)		B	B	B		B	B		C	C	C		C	C	D	D	D	D	D
	0.15uF (154)		B	B	B		B	C		C	C	C		C	C	D	D	D	D	D
	0.22uF (224)		B	B	B		B	C		C	C	C		C	C	D	D	D	D	D
	0.33uF (334)		B	B	B		B			C	C	C		C	C	D	D	D	D	D
	0.47uF (474)		B	B	B		B			C	C	C		C		D	D	D	D	D
	0.68uF (684)		B	B	B		B			C	C	C		C		D	D	D	D	D
	1.0uF (105)		C	C	C		C			C	C	C		C		D	D	D	D	D
	1.5uF (155)		C	C	C					C	C	C				D	D	D	D	
	2.2uF (225)		C	C	C					C	C	C		G		D	D	D	D	
	3.3uF (335)		J	J	J					C	C	C				D	D	D	D	
	4.7uF (475)		J	J	J	J				C	C	D		G		D	D	D	D	
	6.8uF (685)		J	J						C	C	D				D	D	D	D	
10uF (106)		J	J						D	D	G	K			D	D	D			
22uF (226)		P								K	K									
47uF (476)									K	K						M				
100uF (107)									M											

X7S Dielectric

Dielectric		X7S																						
Size		0402				0603				0805				1206				1210						
Rated Voltage (VDC)		6.3	10	16	25	6.3	10	16	25	10	16	25	50	100	6.3	10	16	25	50	6.3	10	16	25	50
Capacitance	1.0uF (105)		E										I											
	1.5uF (155)																							
	2.2uF (225)	E	E					X	X															
	3.3uF (335)																							
	4.7uF (475)						X	X				I	I											
	6.8uF (685)																							
	10uF (106)										I	I												
	22uF (226)																	P*						
	47uF (476)																	P*						
100uF (107)																					M*			

1. The letter in cell is expressed the symbol of product thickness.
2. The letter in cell with "*" mark is expressed: "M tolerance"(20%) only
3. For more information about products with special capacitance or other data, please contact WTC local representative.

■ **FEATURES**

- * High capacitance in unit size.
- * High precision dimensional tolerances.
- * Suitable used in high-accuracy automatic mounting machine.

■ **GENERAL ELECTRICAL DATA**

Size	01R5		
Dielectric	NP0	X7R	X5R
Capacitance*	0.2pF to 100pF	100pF & 1000pF	1000pF to 0.033μF
Capacitance tolerance**	Cap≤10pF: C (±0.25pF) Cap>10pF: J (±5%)	K (±10%), M (±20%)	
Rated voltage (WVDC)	16V, 25V, 50V	10V	6.3V, 10V
Operating temperature	-55 to +125°C	-55 to +125°C	-55 to +85°C
Capacitance change	±30ppm	±15%	
Termination	Ni/Sn (lead-free termination)		

■ **EXPLANATION OF PART NUMBERS**

01R5	N	100	J	160	C	I
Size (Inch (mm))	Dielectric	Capacitance	Tolerance	Rated voltage	Termination	Packaging
01R5 =01005 (0402)	N=NP0(C0G)	100=10x10 ⁰ =10pF	J=±5%	160=16 VDC	C=Cu/Ni/Sn	T=7" reeled

Please refer to page 2 "How to order" for more information.

■ **CAPACITANCE RANGE**

SIZE	01R5		
	DIELECTRIC		
	NP0		
RATED VOLTAGE (VDC)	16	25	50
0.2pF (0R2)	√	√	√
0.3pF (0R3)	√	√	√
0.4pF (0R4)	√	√	√
0.5pF (0R5)	√	√	√
1.0pF (1R0)	√	√	√
1.5pF (1R5)	√	√	√
2.0pF (2R0)	√	√	√
3.0pF (3R0)	√	√	√
4.0pF (4R0)	√	√	√
5.0pF (5R0)	√	√	√
6.0pF (6R0)	√	√	√
7.0pF (7R0)	√	√	√
8.0pF (8R0)	√	√	√
9.0pF (9R0)	√	√	√
10pF (100)	√	√	√
12pF (120)	√	√	√
15pF (150)	√	√	√
18pF (180)	√	√	√
22pF (220)	√	√	√
27pF (270)	√	√	√
33pF (330)	√	√	√
39pF (390)	√	√	√
47pF (470)	√	√	√
56pF (560)	√	√	√
68pF (680)	√	√	√
82pF (820)	√	√	√
100pF (101)	√	√	√

SIZE	01R5	
	DIELECTRIC	
	X7R	
RATED VOLTAGE (VDC)	10	
100pF (101)	√	
120pF (121)		
150pF (151)	√	
180pF (181)		
220pF (221)	√	
270pF (271)		
330pF (331)	√	
390pF (391)		
470pF (471)	√	
560pF (561)		
680pF (681)		
820pF (821)		
1,000pF (102)	√	

SIZE	01R5	
	DIELECTRIC	
	X5R	
RATED VOLTAGE (VDC)	6.3	10
1,000pF (102)	√	√
1,500pF (152)		√
2,200pF (222)		√
3,300pF (332)		√
4,700pF (472)		√
6,800pF (682)		√
0.010μF (103)	√	√
0.015μF (153)		
0.022μF (223)	√	
0.033μF (333)	√	
0.047μF (473)		
0.068μF (683)		
0.10μF (104)		

1. The letter in cell is expressed the symbol of product thickness.
2. For more information about products with special capacitance or other data, please contact WTC local representative

■ **FEATURES**

* High voltage in a given case size.

* High stability and reliability.

■ **GENERAL ELECTRICAL DATA**

Dielectric	NP0	X7R	Y5V
Size	0402, 0603, 0805, 1206, 1210, 1808, 1812, 1825, 2220, 2225		0805, 1206, 1210, 1812
Capacitance	0.5pF to 0.1μF		0.01μF to 0.68μF
Capacitance tolerance	Cap≤5pF: C (±0.25pF) 5pF<Cap<10pF: D (±0.5pF) Cap≥10pF: J (±5%), K (±10%)	K (±10%), M (±20%)	Z (-20/+80%)
Rated voltage (WVDC)	200V to 4000V		200V, 250V
DF/ Q	Cap<30pF: Q≥400+20C Cap≥30pF: Q≥1000	≤2.5%	≤5%
Insulation resistance at Ur	Ur=200~630V: ≥10GΩ or RxC≥100Ω-F whichever is smaller Ur=1000~3000V: ≥10GΩ		
Dielectric strength	200~300V: ≥2 x WVDC 400V~450V: ≥1.2 x WVDC 500~999V: ≥1.5 x WVDC 1000~3000V: ≥1.2 x WVDC 4000: ≥1.1 x WVDC		
Operating temperature	-55 to +125°C		-25 to +85°C
Capacitance characteristic	±30ppm	±15%	+30/-80%
Termination	Ni/Sn (lead-free termination)		

■ **EXPLANATION OF PART NUMBERS**

<u>1808</u>	<u>N</u>	<u>100</u>	<u>J</u>	<u>202</u>	<u>C</u>	<u>I</u>
Size (Inch (mm)) 1808 (4520)	Dielectric N=NP0(C0G)	Capacitance 100=10x10 ⁰ =10pF	Tolerance J=±5%	Rated voltage 202=2000 VDC	Termination C=Cu/Ni/Sn	Packaging style T=7" reeled

Please refer to page 2 "How to order" for more information.

■ **CAPACITANCE RANGE**

Y5V Dielectric 200V to 250V

DIELECTRIC		Y5V							
SIZE		0805		1206		1210		1812	
RATED VOLTAGE (VDC)		200	250	200	250	200	250	200	250
Capacitance	0.010μF (103)	B	B	B	B	C	C	D	D
	0.015μF (153)	B	B	B	B	C	C	D	D
	0.022μF (223)	B	B	B	B	C	C	D	D
	0.033μF (333)	B	B	B	B	C	C	D	D
	0.047μF (473)	B	B	B	B	C	C	D	D
	0.068μF (683)	B	B	B	B	C	C	D	D
	0.10μF (104)			B	B	C	C	D	D
	0.15μF (154)			C	C	C	C	D	D
	0.22μF (224)							D	D
	0.33μF (334)							D	D
	0.47μF (474)							D	D
	0.68μF (684)							D	D

1. The letter in cell is expressed the symbol of product thickness.

2. For more information about products with special capacitance or other data, please contact WTC local representative.

■ **FEATURES**

- * High voltage in a given case size.
- * High stability and reliability.

■ **GENERAL ELECTRICAL DATA**

Dielectric	X7R
Size	1206, 1210, 1808, 1812, 1825, 2220, 2225
Capacitance	100pF to 0.018μF
Capacitance tolerance	K (±10%), M (±20%)
Rated voltage (WVDC)	2500V to 4000V
DF(Tan δ)	DF≤2.5%
Dielectric strength	1000~3000V: ≥1.2 x WVDC, 4000: ≥1.1 x WVDC
Operating temperature	-55 to +125°C
Capacitance characteristic	±15%
Termination	Ni/Sn (lead-free termination)

■ **EXPLANATION OF PART NUMBERS**

1808	B	102	K	302	M	I
Size (Inch (mm))	Dielectric	Capacitance	Tolerance	Rated voltage	Termination	Packaging style
1808 (4520)	B=X7R	100=10x10 ² =1000pF	K=±10%	302=3000 VDC	M= Surface coating, Cu/Ni/Sn	T=7" reeled

Please refer to page 2 "How to order" for more information.

■ **CAPACITANCE RANGE**

DIELECTRIC	X7R										
	SIZE	1206	1210	1808	1812		1825		2220		2225
RATED VOLTAGE (VDC)	2500	2000	4000	3000	4000	3000	4000	3000	4000	3000	4000
Capacitance	100pF (101)										
	120pF (121)										
	150pF (151)			K							
	180pF (181)			K							
	220pF (221)			K							
	270pF (271)			K		K		K		K	
	330pF (331)			K		K		K		K	
	390pF (391)			K		K		K		K	
	470pF (471)			K		K		K		K	
	560pF (561)			K		K		K		K	
	680pF (681)	D		K		K		K		K	
	820pF (821)	D		K		K		K		K	
	1,000pF (102)	D		K		K		K		K	
	1,200pF (122)					M		M		M	
	1,500pF (152)					M		M		M	
	1,800pF (182)					M		M		M	
	2,200pF (222)					M		K		K	
	2,700pF (272)					M		K		K	
	3,300pF (332)					M		K		K	
	3,900pF (392)							K		K	
	4,700pF (472)							K		K	
	5,600pF (562)		M					M		K	
	6,800pF (682)		M					M		M	
	8,200pF (822)		M					M		M	
	0.010μF (103)							M		M	
	0.012μF (123)							U		U	
	0.015μF (153)							U		U	
	0.018μF (183)							U		U	
0.022μF (223)											
0.033μF (333)											
0.047μF (473)											
0.056μF (563)											
0.068μF (683)											
0.10μF (104)											

1. The letter in cell is expressed the symbol of product thickness.

2 For more information about products with special capacitance or other data, please contact WTC local representative.

■ **FEATURES**

- * High Q and low ESR performance at high frequency.
- * Quality improvement of telephone calls for low power loss and better performance.

■ **GENERAL ELECTRICAL DATA**

Dielectric	NP0
Size	0201, 0402, 0603,0805
Capacitance	0.3pF to 3300pF
Capacitance tolerance	Cap≤5pF: B (±0.1pF), C (±0.25pF) 5pF<Cap<10pF: C (±0.25pF), D (±0.5pF) Cap≥10pF: F (±1%), G (±2%), J (±5%)
Rated voltage (WVDC)	10V, 16V, 25V, 50V, 100V, 200V, 250V, 500V, 630V
Q	Cap<30pF: Q≥400+20C Cap≥30pF: Q≥1000
Insulation resistance at Ur	≥10GΩ
Operating temperature	-55 to +125°C
Capacitance change	±30ppm
Termination	Ni/Sn (lead-free termination)

■ **EXPLANATION OF PART NUMBERS**

HH	15	N	100	G	500	C	I
Series	Size (Inch (mm))	Dielectric	Capacitance	Tolerance	Rated voltage	Termination	Packaging
HH=High Q/ Low ESR	15=0402 (1005)	N=NP0 (C0G)	100=10x10 ⁰ =10pF	G=±2%	500=50 VDC	C=Cu/Ni/Sn	T=7" reeled

* Please refer to page 2 "How to order" for more information.

■ **ELECTRICAL CHARACTERISTICS**

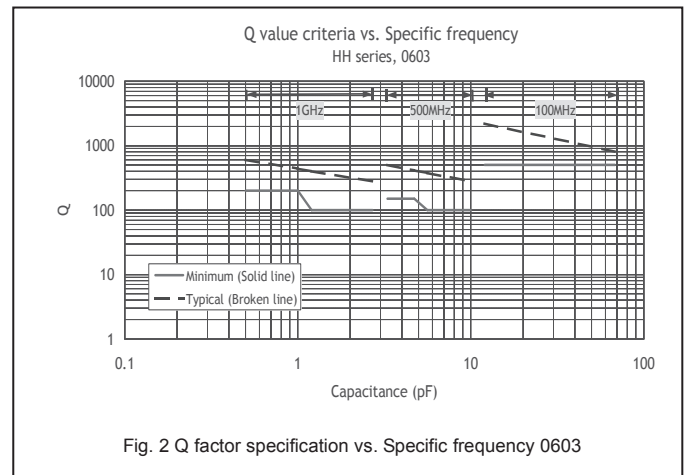
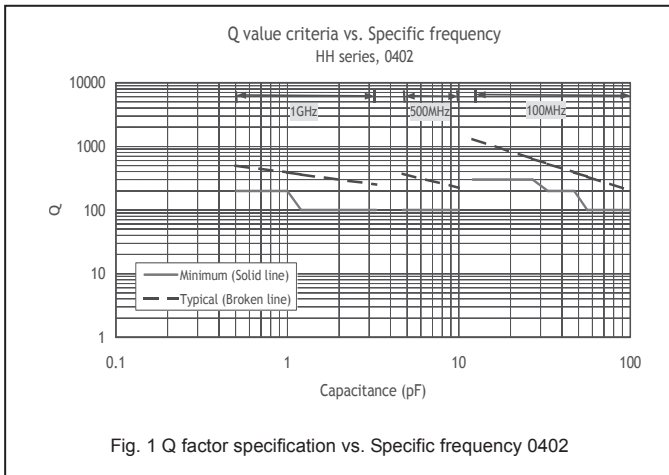

■ CAPACITANCE RANGE

DIELECTRIC		NP0													
SIZE		0201		0402				0603				0805			
Rated Voltage (VAC)		10 16	25 50	16	25	50	100	16	25	50	100	50	100	200 250	500 630
Capacitance	0.3pF (0R3)	L	L	N	N	N	N								
	0.4pF (0R4)	L	L	N	N	N	N								
	0.5pF (0R5)	L	L	N	N	N	N	S	S	S	S	B	B		
	0.6pF (0R6)	L	L	N	N	N	N	S	S	S	S	B	B		
	0.7pF (0R7)	L	L	N	N	N	N	S	S	S	S	B	B		
	0.8pF (0R8)	L	L	N	N	N	N	S	S	S	S	B	B		
	0.9pF (0R9)	L	L	N	N	N	N	S	S	S	S	B	B		
	1.0pF (1R0)	L	L	N	N	N	N	S	S	S	S	B	B	B	B
	1.2pF (1R2)	L	L	N	N	N	N	S	S	S	S	B	B	B	B
	1.5pF (1R5)	L	L	N	N	N	N	S	S	S	S	B	B	B	B
	1.8pF (1R8)	L	L	N	N	N	N	S	S	S	S	B	B	B	B
	2.0pF (2R0)	L	L	N	N	N	N	S	S	S	S	B	B	B	B
	2.2pF (2R2)	L	L	N	N	N	N	S	S	S	S	B	B	B	B
	2.7pF (2R7)	L	L	N	N	N	N	S	S	S	S	B	B	B	B
	3.0pF (3R0)	L	L	N	N	N	N	S	S	S	S	B	B	B	B
	3.3pF (3R3)	L	L	N	N	N	N	S	S	S	S	B	B	B	B
	3.9pF (3R9)	L	L	N	N	N	N	S	S	S	S	B	B	B	B
	4.0pF (4R0)	L	L	N	N	N	N	S	S	S	S	B	B	B	B
	4.7pF (4R7)	L	L	N	N	N	N	S	S	S	S	B	B	B	B
	5.0pF (5R0)	L	L	N	N	N	N	S	S	S	S	B	B	B	B
	5.6pF (5R6)	L	L	N	N	N	N	S	S	S	S	B	B	B	B
	6.0pF (6R0)	L	L	N	N	N	N	S	S	S	S	B	B	B	B
	6.8pF (6R8)	L	L	N	N	N	N	S	S	S	S	B	B	B	B
	7.0pF (7R0)	L	L	N	N	N	N	S	S	S	S	B	B	B	B
	8.0pF (8R0)	L	L	N	N	N	N	S	S	S	S	B	B	B	B
	8.2pF (8R2)	L	L	N	N	N	N	S	S	S	S	B	B	B	B
	9.0pF (9R0)	L	L	N	N	N	N	S	S	S	S	B	B	B	B
	10pF (100)	L	L	N	N	N	N	S	S	S	S	B	B	B	B
	12pF (120)	L	L	N	N	N	N	S	S	S	S	B	B	B	B
	15pF (150)	L	L	N	N	N	N	S	S	S	S	B	B	B	B
	18pF (180)	L	L	N	N	N	N	S	S	S	S	B	B	B	B
	22pF (220)	L	L	N	N	N	N	S	S	S	S	B	B	B	B
	27pF (270)	L	L	N	N	N	N	S	S	S	S	B	B	B	B
33pF (330)	L	L	N	N	N	N	S	S	S	S	B	B	B	B	
39pF (390)			N	N	N	N	S	S	S	S	B	B	B	B	
47pF (470)			N	N	N	N	S	S	S	S	B	B	B	B	
56pF (560)			N	N	N	N	S	S	S	S	B	B	B	B	
68pF (680)			N	N	N	N	S	S	S	S	B	B	B	B	
82pF (820)			N	N	N	N	S	S	S	S	B	B	B	B	
100pF (101)			N	N	N	N	S	S	S	S	B	B	B	B	
120pF (121)			N	N	N	N	S	S	S	S	D	D	D	D	
150pF (151)			N	N	N	N	S	S	S	S	D	D	D	D	
180pF (181)			N	N	N	N	S	S	S	S			D	D	
220pF (221)			N	N	N	N	S	S	S	S			D	D	
270pF (271)			N	N	N	N	S	S	S	S			D	D	
330pF (331)			N	N	N	N	S	S	S	S			D	D	
390pF (391)			N	N	N	N	S	S	S	S			D	D	
470pF (471)			N	N	N	N	S	S	S	S					
560pF (561)							S	S	S	S					
680pF (681)							S	S	S	S					
820pF (821)							S	S	S	S					
1,000pF (102)							S	S	S	S					
1,200pF (122)							X	X	X						
1,500pF (152)							X	X	X						
1,800pF (182)							X	X	X						
2,200pF (222)							X	X	X						
2,700pF (272)							X	X	X						
3,300pF (332)							X	X	X						

1. The letter in cell is expressed the symbol of product thickness.
2. For more information about products with special capacitance or other data, please contact WTC local representative.

■ **FEATURES**

- * Ultra high Q and low ESR performance at high frequency.
- * Quality improvement of telephone calls for low power loss and better performance.

■ **GENERAL ELECTRICAL DATA**

Dielectric	NP0			
Size	01005, 0201, 0402, 0603, 0805, 0505, 1111			
Capacitance	0.1pF to 1000pF			
Capacitance tolerance	Cap \leq 5pF: P (\pm 0.02pF)*, Q (\pm 0.03pF)*, A (\pm 0.05pF), B (\pm 0.1pF), C (\pm 0.25pF) 5pF<Cap<10pF: B (\pm 0.1pF), C (\pm 0.25pF), D (\pm 0.5pF) Cap \geq 10pF: F (\pm 1%), G (\pm 2%), J (\pm 5%) (*Capacitance tolerance "P & Q" only for 0402/Cap \leq 1pF/25V&50V products.)			
Rated voltage (WVDC)	6.3V, 10V, 25V, 50V, 100V, 250V, 500V, 1500V			
Q	01005, 0201, 0402/25V~50V: Cap<30pF: Q \geq 400+20C; Cap \geq 30pF: Q \geq 1000 0402/100V~200V, 0603, 0805, 0505, 1111: Cap<30pF:Q \geq 800+20C; Cap \geq 30pF: Q \geq 1400			
ESR	01005	0201	0402	0505
	0.2pF \leq Cap \leq 1pF:< 700m Ω /pF	0.1pF \leq Cap \leq 1pF:< 350m Ω /pF	0.1pF \leq Cap \leq 1pF:< 350m Ω /pF	0.4pF \leq Cap<1.0pF: < 1500m Ω
	1pF<Cap \leq 2pF:< 600m Ω	1pF<Cap \leq 5pF:< 300m Ω	1pF<Cap \leq 5pF:< 300m Ω	1.0pF \leq Cap<10pF: < 250m Ω
	2pF<Cap \leq 5pF:< 500m Ω	5pF<Cap \leq 22pF:< 250m Ω	5pF<Cap \leq 100pF:< 250m Ω	10pF \leq Cap \leq 100pF: < 200m Ω
	5pF<Cap \leq 10pF:< 300m Ω			
	10pF<Cap \leq 22pF:< 350m Ω			
	0603	0805		
	0.3pF \leq Cap \leq 1pF:< 1500m Ω	0.3pF \leq Cap \leq 1pF: < 1500m Ω		
	1pF<Cap \leq 10pF:< 250m Ω	1pF<Cap \leq 10pF: < 250m Ω		
	10pF<Cap \leq 220pF:< 200m Ω	Cap>10pF: < 200m Ω		
Insulation resistance at Ur	\geq 10G Ω or RxC \geq 100 Ω -F whichever is smaller.			
Operating temperature	-55 to +125°C			
Capacitance change	\pm 30ppm/°C; 0201Cap \geq 22pF, \pm 60ppm/°C			
Termination	Ni/Sn (lead-free termination)			

■ **EXPLANATION OF PART NUMBERS**

RF	15	N	100	G	500	C	I
Series	Size (Inch (mm))	Dielectric	Capacitance	Tolerance	Rated voltage	Termination	Packaging
RF=Microwave	15=0402 (1005)	N=NP0	100=10x10 ⁰ =10pF	G= \pm 2%	500=50 VDC	C=Cu/Ni/Sn	T=7" reeled

■ **EXPLANATION OF PART NUMBERS FOR 0402 SIZE WITH NARROW TOLERANCE**

UF	15	N	R05	P	250	C	I
Series	Size (Inch (mm))	Dielectric	Capacitance	Tolerance	Rated voltage	Termination	Packaging
UF=Ultra Microwave	15=0402 (1005)	N=NP0	R05=0.05pF	P= \pm 0.02pF Q= \pm 0.03pF	250=25 VDC 500=50 VDC	C=Cu/Ni/Sn	T=7" reeled

■ **ELECTRICAL CHARACTERISTICS**

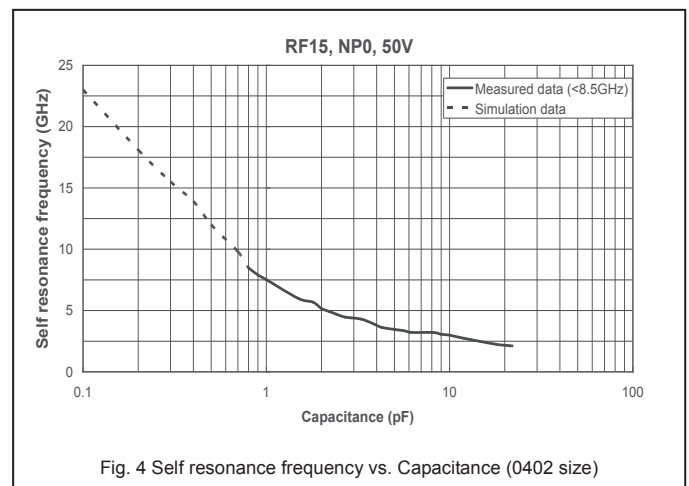
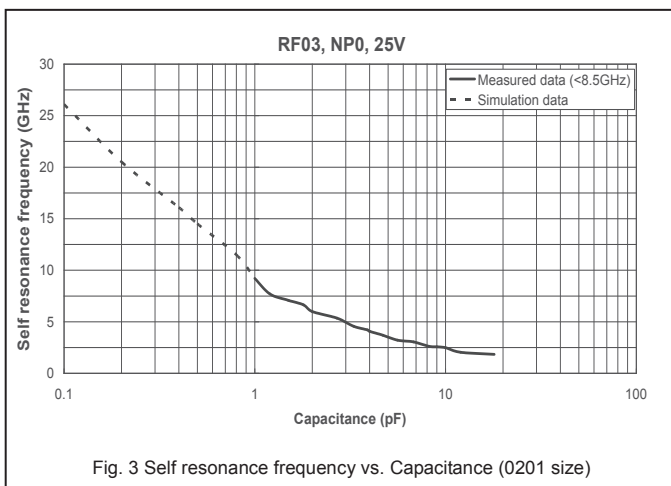

■ CAPACITANCE RANGE

DIELECTRIC		NP0																			
SIZE		01005		0201		0402				0603			0805				0505	1111			
RATED VOLTAGE (VDC)		16	25	6.3 10 25	50	100	25	50	100	200	50	100	250	50	100	250	500	50 100 250	50 100 200 250 500	1500	
Capacitance	0.05pF(0R5)						N*	N*													
	0.1pF (0R1)			L	L	L	N*	N*	N	N	H	H	H	A	A	A	A				
	0.2pF (0R2)	V	V	L	L	L	N*	N*	N	N	H	H	H	A	A	A	A				
	0.3pF (0R3)	V	V	L	L	L	N*	N*	N	N	S	S	S	T	T	T	T				
	0.4pF (0R4)	V	V	L	L	L	N*	N*	N	N	S	S	S	T	T	T	T	J			
	0.5pF (0R5)	V	V	L	L	L	N*	N*	N	N	S	S	S	T	T	T	T	J			
	0.6pF (0R6)	V	V	L	L	L	N*	N*	N	N	S	S	S	T	T	T	T	J			
	0.7pF (0R7)	V	V	L	L	L	N*	N*	N	N	S	S	S	T	T	T	T	J			
	0.8pF (0R8)	V	V	L	L	L	N*	N*	N	N	S	S	S	T	T	T	T	J			
	0.9pF (0R9)	V	V	L	L	L	N*	N*	N	N	S	S	S	T	T	T	T	J			
	1.0pF (1R0)	V	V	L	L	L	N*	N*	N	N	S	S	S	T	T	T	T	J	G	G	
	1.2pF (1R2)	V	V	L	L	L	N	N	N	N	S	S	S	T	T	T	T	J	G	G	
	1.5pF (1R5)	V	V	L	L	L	N	N	N	N	S	S	S	T	T	T	T	J	G	G	
	1.8pF (1R8)	V	V	L	L	L	N	N	N	N	S	S	S	T	T	T	T	J	G	G	
	2.0pF (2R0)	V	V	L	L	L	N	N	N	N	S	S	S	T	T	T	T	J	G	G	
	2.2pF (2R2)	V	V	L	L	L	N	N	N	N	S	S	S	T	T	T	T	J	G	G	
	2.7pF (2R7)	V	V	L	L	L	N	N	N	N	S	S	S	T	T	T	T	J	G	G	
	3.0pF (3R0)	V	V	L	L	L	N	N	N	N	S	S	S	T	T	T	T	J	G	G	
	3.3pF (3R3)	V	V	L	L	L	N	N	N	N	S	S	S	T	T	T	T	J	G	G	
	3.9pF (3R9)	V	V	L	L	L	N	N	N	N	S	S	S	T	T	T	T	J	G	G	
	4.0pF (4R0)	V	V	L	L	L	N	N	N	N	S	S	S	T	T	T	T	J	G	G	
	4.7pF (4R7)	V	V	L	L	L	N	N	N	N	S	S	S	T	T	T	T	J	G	G	
	5.0pF (5R0)	V	V	L	L	L	N	N	N	N	S	S	S	T	T	T	T	J	G	G	
	5.6pF (5R6)	V	V	L	L	L	N	N	N	N	S	S	S	T	T	T	T	J	G	G	
	6.0pF (6R0)	V	V	L	L	L	N	N	N	N	S	S	S	T	T	T	T	J	G	G	
	6.8pF (6R8)	V		L	L	L	N	N	N	N	S	S	S	T	T	T	T	J	G	G	
	7.0pF (7R0)	V		L	L	L	N	N	N	N	S	S	S	T	T	T	T	J	G	G	
	8.0pF (8R0)	V		L	L	L	N	N	N	N	S	S	S	T	T	T	T	J	G	G	
	8.2pF (8R2)	V		L	L	L	N	N	N	N	S	S	S	T	T	T	T	J	G	G	
	9.0pF (9R0)	V		L	L	L	N	N	N	N	S	S	S	T	T	T	T	J	G	G	
	10pF (100)	V	V	L	L	L	N	N	N	N	S	S	S	T	T	T	T	J	G	G	
	11pF (110)	V	V	L	L		N	N	N	N	S	S	S	T	T	T	T	J	G	G	
	12pF (120)	V	V	L	L		N	N	N	N	S	S	S	T	T	T	T	J	G	G	
	13pF (130)	V	V	L	L		N	N	N	N	S	S	S	T	T	T	T	J	G	G	
	15pF (150)	V	V	L	L		N	N	N	N	S	S	S	T	T	T	T	J	G	G	
	16pF (160)	V	V	L	L		N	N	N	N	S	S	S	T	T	T	T	J	G	G	
	18pF (180)	V	V	L	L		N	N	N	N	S	S	S	T	T	T	T	J	G	G	
	20pF (200)	V	V	L	L		N	N	N	N	S	S	S	T	T	T	T	J	G	G	
	22pF (220)	V	V	L			N	N	N	N	S	S	S	T	T	T	T	J	G	G	
	24pF (240)			L			N	N	N	N	S	S	S	T	T	T	T	J	G	G	
	27pF (270)			L			N	N	N	N	S	S	S	T	T	T	T	J	G	G	
	30pF (300)			L			N	N	N	N	S	S	S	T	T	T	T	J	G	G	
33pF (330)			L			N	N	N	N	S	S	S	T	T	T	T	J	G	G		
36pF (360)						N	N	N		S	S	S	T	T	T	T	J	G			
39pF (390)						N	N	N		S	S	S	T	T	T	T	J	G			
43pF (430)						N	N	N		S	S	S	T	T	T	T	J	G			
47pF (470)						N	N	N		S	S	S	T	T	T	T	J	G			
56pF (560)						N	N	N		S	S	S	T	T	T	T	J	G			
68pF (680)						N	N			S	S	S	T	T	T	T	J	G			
82pF (820)						N	N			S	S	S	T	T	T	T	J	G			
100pF (101)						N	N			S	S	S	T	T	T	T	J	G			
120pF (121)										S			T	T	T				G		
150pF (151)										S			T	T	T				G		
180pF (181)										S			T	T	T				G		
220pF (221)										S			T	T	T				G		
270pF (271)																			G		
330pF (331)																			G		
390pF (391)																			G		
470pF (471)																			G		
560pF (561)																			G		
680pF (681)																			G		
820pF (821)																			G		
1,000pF (102)																			G		

1. The letter in cell is expressed the symbol of product thickness.
2. The letter in cell with "*" mark is expressed the Capacitance tolerance extend to "P (±0.02pF), Q (±0.03pF)".
3. For more information about products with special capacitance or other data, please contact WTC local representative.

■ **FEATURES**

- * High Q and low ESR performance at high frequency.
- * Ultra low capacitance to 0.1pF.
- * Ultra high reliability (150°C / 2000hrs / 200% Rated Voltage).
- * Can offer high precision tolerance to ±0.05pF.
- * Quality improvement of telephone calls for low power loss and better performance

■ **GENERAL ELECTRICAL DATA**

Dielectric	NPO
Size	0402, 0505, 0603, 0805,
Capacitance	0.1pF to 10pF
Capacitance tolerance	Cap≤5pF: A (±0.05pF), B (±0.1pF), C (±0.25pF) 5pF<Cap<10pF: B (±0.1pF), C (±0.25pF), D (±0.5pF) Cap≥10pF: F (±1%), G (±2%), J (±5%)
Rated voltage (WVDC)	200V, 250V
Q	0402/25V~50V: Cap≤3pF:Q≥400+20C 0402/100V~200V, 0603, 0805, 0505: Cap≤10pF:Q≥800+20C
Insulation resistance at Ur	≥10GΩ or RxC≥100Ω·F whichever is smaller.
Operating temperature	-55 to +150°C
Capacitance change	±30ppm/°C
Termination	Ni/Sn (lead-free termination)

■ **EXPLANATION OF PART NUMBERS**

RH	18	N	100	G	251	C	I
Series	Size (Inch (mm))	Dielectric	Capacitance	Tolerance	Rated voltage	Termination	Packaging
RH=Microwave Cap with High reliability	18=0603 (1608)	N=NPO	100=10x100=10pF	G=±2%	251=250 VDC	C=Cu/Ni/Sn	T=7" reeled

* Please refer to page 2 "How to order" for more information.

■ **CAPACITANCE RANGE**

DIELECTRIC		NPO			
SIZE		0402	0603	0805	0505
RATED VOLTAGE (VDC)		200	250	250	250
Capacitance	0.1pF (0R1)	N			
	0.2pF (0R2)	N			
	0.3pF (0R3)	N	S	T	
	0.4pF (0R4)	N	S	T	J
	0.5pF (0R5)	N	S	T	J
	0.6pF (0R6)	N	S	T	J
	0.7pF (0R7)	N	S	T	J
	0.8pF (0R8)	N	S	T	J
	0.9pF (0R9)	N	S	T	J
	1.0pF (1R0)	N	S	T	J
	1.2pF (1R2)	N	S	T	J
	1.5pF (1R5)	N	S	T	J
	1.8pF (1R8)	N	S	T	J
	2.0pF (2R0)	N	S	T	J
	2.2pF (2R2)	N	S	T	J
	2.7pF (2R7)	N	S	T	J
	3.0pF (3R0)	N	S	T	J
	3.3pF (3R3)		S	T	J
	3.9pF (3R9)		S	T	J
	4.0pF (4R0)		S	T	J
4.7pF (4R7)		S	T	J	
5.0pF (5R0)		S	T	J	
5.6pF (5R6)		S	T	J	
6.0pF (6R0)		S	T	J	
6.8pF (6R8)		S	T	J	
7.0pF (7R0)		S	T	J	
8.0pF (8R0)		S	T	J	
8.2pF (8R2)		S	T	J	
9.0pF (9R0)		S	T	J	
10pF (100)		S	T	J	

1. The letter in cell is expressed the symbol of product thickness.

2. For more information about products with special capacitance or other data, please contact WTC local representative.

■ **FEATURES**

* MLCC's terminations build a soft & flexible polymer layer to withstand high bending stress in SMT line.

* Available for any item in standard series range.

■ **GENERAL ELECTRICAL DATA**

Dielectric	NP0	X7R
Size	0603, 0805, 1206, 1210, 1808, 1812, 1825, 2220, 2225	
Capacitance range	0.5pF to 0.1μF	100pF to 22μF
Capacitance tolerance	Cap≤5pF: B (±0.1pF), C (±0.25pF) 5pF<Cap<10pF: C (±0.25pF), D (±0.5pF) Cap≥10pF: F (±1%), G (±2%), J (±5%), K (±10%)	J (±5%), K (±10%), M (±20%)
Rated voltage (WVDC)	10V, 16V, 25V, 50V, 100V, 200V, 250V, 500V, 630V, 1000V, 2000V, 3000V	
Operating temperature	-55 to +125°C	
Capacitance characteristic	±30ppm	±15%
Termination	Ni/Sn (lead-free termination)	

■ **EXPLANATION OF PART NUMBERS**

<u>SH</u>	<u>31</u>	<u>N</u>	<u>100</u>	<u>J</u>	<u>501</u>	<u>C</u>	<u>I</u>
Series	Size (Inch (mm))	Dielectric	Capacitance	Tolerance	Rated voltage	Termination	Packaging
SH=With Ag polymer	31=1206 (3216)	N=NP0(C0G)	100=10x100=10pF	J=±5%	501=500 VDC	C=Cu/Ni/Sn	T=7" reeled

* Please refer to page 2 "How to order" for more information.

■ **PACKAGING DIMENSION AND QUANTITY**

Size	L(mm)	W(mm)	Thickness (mm)/Symbol		Paper tape		Plastic tape	
					7" reel	13" reel	7" reel	13" reel
0402 (1005)	1.00±0.20	0.50±0.20	0.50±0.20	E	1,000	-	-	-
0603 (1608)	1.60±0.20	0.80±0.10	0.80±0.07	S	4,000	15,000	-	-
	1.60±0.30	0.80±0.30	0.80±0.30	X	4,000	15,000	-	-
0805 (2012)	2.00±0.20	1.25±0.10	0.60±0.10	A	4,000	15,000	-	-
			0.80±0.10	B	4,000	15,000	-	-
	2.00±0.30	1.25±0.30	1.25±0.30	I	-	-	3,000	10,000
1206 (3216)	3.20+0.4/-0.1	1.60±0.15	0.80±0.10	B	4,000	15,000	-	-
			0.95±0.10	C	-	-	3,000	10,000
			1.15±0.15	J	-	-	3,000	10,000
			1.25±0.10	D	-	-	3,000	10,000
	3.20+0.4/-0.1	1.60±0.20	1.60±0.20	G	-	-	2,000	10,000
3.20±0.50	1.60±0.50	1.60±0.50	P	-	-	2,000	9,000	
1210 (3225)	3.20±0.40	2.50±0.20	0.95±0.10	C	-	-	3,000	10,000
			1.25±0.10	D	-	-	3,000	10,000
	3.20±0.60	2.50±0.50	1.60±0.20	G	-	-	2,000	10,000
			2.00±0.20	K	-	-	1,000	6,000
			2.50±0.50	M	-	-	1,000	6,000
1808 (4520)	4.50+0.60/-0.4	2.03±0.25	1.25±0.10	D	-	-	2,000	-
			2.00±0.20	K	-	-	1,000	-
1812 (4532)	4.50+0.60/-0.4	3.20±0.30	1.25±0.10	D	-	-	1,000	-
		3.20±0.40	2.50±0.50	M	-	-	500	3,000
1825 (4563)	4.50+0.6/-0.4	6.30±0.40	1.60±0.20	G	-	-	1000	-
2220 (5750)	5.70±0.50	5.00±0.40	2.00±0.20	K	-	-	1000	-
			2.50±0.30	M	-	-	500	-
2225 (5763)	5.70±0.50	6.30±0.40	2.80±0.30	U	-	-	500	-

Unit: pieces

■ CAPACITANCE RANGE (SH Series)

NP0 Dielectric (0402 to 1812 Size)

DIELECTRIC	NP0																																				
	0402		0603		0805				1206				1210				1808		1812																		
SIZE	10, 16, 25, 50	100	10, 16, 25, 50	100	200, 250	10, 16, 25, 50	100	200	250	500, 630	1000	10, 16, 25, 50	100	200	250	500, 630	1000	1500, 2000	10, 16, 25, 50, 100	200, 250	500, 630	1000	1500, 2000	500, 630	1000	1500, 2000	3000	10, 16, 25, 50, 100	200, 250	500, 630	1000	1500, 2000	3000				
RATED VOLTAGE (VDC)	10, 16, 25, 50	100	10, 16, 25, 50	100	200, 250	10, 16, 25, 50	100	200	250	500, 630	1000	10, 16, 25, 50	100	200	250	500, 630	1000	1500, 2000	10, 16, 25, 50, 100	200, 250	500, 630	1000	1500, 2000	500, 630	1000	1500, 2000	3000	10, 16, 25, 50, 100	200, 250	500, 630	1000	1500, 2000	3000				
0.5pF (0R5)	E	E	S	S	S	A	A	A	A	A	D																										
1.0pF (1R0)	E	E	S	S	S	A	A	A	A	A	D																										
1.2pF (1R2)	E	E	S	S	S	A	A	A	A	A	D																										
1.5pF (1R5)	E	E	S	S	S	A	A	A	A	A	D	B	B	B	B	B	B																				
1.8pF (1R8)	E	E	S	S	S	A	A	A	A	A	D	B	B	B	B	B	B																				
2.2pF (2R2)	E	E	S	S	S	A	A	A	A	A	D	B	B	B	B	B	B								D	D	D	D									
2.7pF (2R7)	E	E	S	S	S	A	A	A	A	A	D	B	B	B	B	B	B								D	D	D	D									
3.3pF (3R3)	E	E	S	S	S	A	A	A	A	A	D	B	B	B	B	B	B								D	D	D	D									
3.9pF (3R9)	E	E	S	S	S	A	A	A	A	A	D	B	B	B	B	B	B								D	D	D	D									
4.7pF (4R7)	E	E	S	S	S	A	A	A	A	A	D	B	B	B	B	B	B								D	D	D	D									
5.6pF (5R6)	E	E	S	S	S	A	A	A	A	A	D	B	B	B	B	B	B								D	D	D	D									
6.8pF (6R8)	E	E	S	S	S	A	A	A	A	A	D	B	B	B	B	B	B								D	D	D	D									
8.2pF (8R2)	E	E	S	S	S	A	A	A	A	A	D	B	B	B	B	B	B								D	D	D	D									
10pF (100)	E	E	S	S	S	A	A	A	A	A	D	B	B	B	B	B	B	C	C	C	C	C	C	D	D	D	D	D	D	D	D	D	D	D	D	D	
12pF (120)	E	E	S	S	S	A	A	A	A	A	D	B	B	B	B	B	B	C	C	C	C	C	C	D	D	D	D	D	D	D	D	D	D	D	D	D	
15pF (150)	E	E	S	S	S	A	A	A	A	A	D	B	B	B	B	B	B	C	C	C	C	C	C	D	D	D	D	D	D	D	D	D	D	D	D	D	
18pF (180)	E	E	S	S	S	A	A	A	A	A	D	B	B	B	B	B	B	C	C	C	C	C	C	D	D	D	D	D	D	D	D	D	D	D	D	D	
22pF (220)	E	E	S	S	S	A	A	A	A	A	D	B	B	B	B	B	B	C	C	C	C	C	C	D	D	D	D	D	D	D	D	D	D	D	D	D	
27pF (270)	E	E	S	S	S	A	A	A	A	A	D	B	B	B	B	B	B	C	C	C	C	C	C	D	D	D	D	D	D	D	D	D	D	D	D	D	
33pF (330)	E	E	S	S	S	A	A	A	A	A	D	B	B	B	B	B	B	C	C	C	C	C	C	D	D	D	D	D	D	D	D	D	D	D	D	D	
39pF (390)	E	E	S	S	S	A	A	A	A	A	D	B	B	B	B	B	B	C	C	C	C	C	C	D	D	D	D	D	D	D	D	D	D	D	D	D	D
47pF (470)	E	E	S	S	S	A	A	A	A	A	D	B	B	B	B	B	C	C	C	C	C	C	C	D	D	D	D	D	D	D	D	D	D	D	D	D	D
56pF (560)	E	E	S	S	S	A	A	A	A	A	D	B	B	B	B	B	C	D	C	C	C	C	C	D	D	D	D	D	D	D	D	D	D	D	D	D	D
68pF (680)	E	E	S	S	S	A	A	A	A	A	D	B	B	B	B	B	C	D	C	C	C	C	C	D	D	D	D	D	D	D	D	D	D	D	D	D	D
82pF (820)	E	E	S	S	S	A	A	A	A	B	D	B	B	B	B	B	D	D	C	C	C	C	D	D	D	D	D	D	D	D	D	D	D	D	D	DD	D
100pF (101)	E	E	S	S	S	A	A	A	B	B	D	B	B	B	B	B	D	D	C	C	C	C	D	D	D	D	D	D	D	D	D	D	D	D	D	D	D
120pF (121)	E	E	S	S	S	A	A	A	B	D	D	B	B	B	B	B	D	G	C	C	C	C	D	D	D	D	D	D	D	D	D	D	D	D	D	D	D
150pF (151)	E	E	S	S	S	A	A	B	D	D	D	B	B	B	B	B	D	G	C	C	C	C	D	G	D	D	D	D	D	D	D	D	D	D	D	D	D
180pF (181)	E	E	S	S	S	A	A	B	D	D	D	B	B	B	B	B	G	G	C	C	C	C	D	G	D	D	D	D	D	D	D	D	D	D	D	D	K
220pF (221)	E	E	S	S	S	A	A	D	D	D	D	B	B	B	B	B	G	G	C	C	C	C	G	G	D	D	D	D	D	D	D	D	D	D	D	D	K
270pF (271)	E		S	S	X	A	A	D	D	D	D	B	B	B	C	C	G	P	C	C	C	C	G	K	K	K	K	K	K	D	D	D	D	D	D	K	K
330pF (331)	E		S	S	X	A	A	D	D	D	D	B	B	B	C	C	G	P	C	C	C	C	G	K	K	K	K	K	D	D	D	D	D	D	D	K	K
390pF (391)	E		S	S	X	B	B	D	D	D	D	B	B	B	C	C	G	P	C	C	C	C	G	M	K	K	K		D	D	D	D	D	D	D	K	K
470pF (471)	E		S	S	X	B	B	D	D	I		B	B	C	C	C	G		C	C	C	G	M	K	K	K		D	D	D	D	D	D	D	K	K	K
560pF (561)	E		S	S		B	B	D	D	I		B	B	C	D	D	G		C	C	C	G		K	K	K		D	D	D	D	D	D	D	K	K	
680pF (681)	E		S	S		B	B	D	D	I		B	B	C	D	D	G		C	C	C	G		K	K	K		D	D	D	D	D	D	D	K	K	
820pF (821)	E		S	S		B	B	D	D	I		B	B	C	G	G	G		C	C	C	G		K	K	D		D	D	D	D	D	D	D	K	K	
1,000pF (102)	E		S	S		B	B	D	D	I		B	B	C	G	G	G		C	D	D	G		K	K	G		D	D	D	D	D	D	D	K	K	
1,200pF (122)			X			B	B	D	D			B	B	C	G	G			C	D	D	G		K	G			D	D	D	D	D	D	D	K		
1,500pF (152)			X			B	B	D	D			B	B	D	G	G			C	D	D	K		K	G			D	D	D	D	D	D	D	K		
1,800pF (182)			X			B	B	D	D			B	B	D	G	G			C	D	D	M		K	K			D	D	D	D	D	D	D	K		
2,200pF (222)			X			B	B	D	D			B	B	D	G	G			C	D	D	M		K	K			D	D	D	D	D	D	D	K		
2,700pF (272)			X			D	D					B	B	D	G	G			C	D	D	M		K				D	D	D	D	D	D	D	K		
3,300pF (332)			X			D	D					B	B	D	G	G			C	D	D	M		K				D	D	D	D	D	D	D	K		
3,900pF (392)						D	D					B	B	D	G	G			C	D	D	M						D	D	D	D	D	D	D	M		
4,700pF (472)						D	D					B	B	D	G	G			C	G								D	D	D	D	D	D	D			
5,600pF (562)						D	D					B	B						C	G								D	D	D	D	D	D	D			
6,800pF (682)						D	D					C	C						C	G								D	D	D	D	D	D	D			
8,200pF (822)						D	D					D	D						C	G								D		D	D	D	D	D			
0.010µF (103)						D						D	D						C	G								D		D	D	D	D	D			
0.012µF (123)												P	P							D								D		D	D	D	D	G			
0.015µF (153)												P	P							D								D		D	D	D	D	G			
0.022µF (223)												P	P															D		D	D	D	D	K			
0.033µF (333)												P																D		D	D	D	D	D			
0.039µF (393)												P																D		D	D	D	D	D			

1. The letter in cell is expressed the symbol of product thickness.
 2. For more information about products with special capacitance or other data, please contact WTC local representative.

■ CAPACITANCE RANGE (SH Series)

X7R Dielectric (0402 to 1812 Size, 10V~250V)

DIELECTRIC	X7R																												
	0402				0603					0805			1206					1210					1812						
SIZE	10 16	25	50	100	10 16	25	50	100	200 250	10 16 25	50	100 200	250	10 16	25	50	100	200 250	10 16	25	50	100	200 250	10 16 25	50	100	200 250		
RATED VOLTAGE (VDC)																													
100pF (101)	E	E	E	E	S	S	S	S	X	D	D	D	D																
120pF (121)	E	E	E	E	S	S	S	S	X	D	D	D	D																
150pF (151)	E	E	E	E	S	S	S	S	X	D	D	D	D	D	D	D	D	D											
180pF (181)	E	E	E	E	S	S	S	S	X	D	D	D	D	D	D	D	D	D											
220pF (221)	E	E	E	E	S	S	S	S	X	D	D	D	D	D	D	D	D	D											
270pF (271)	E	E	E	E	S	S	S	S	X	D	D	D	D	D	D	D	D	D											
330pF (331)	E	E	E	E	S	S	S	S	X	D	D	D	D	D	D	D	D	D											
390pF (391)	E	E	E	E	S	S	S	S	X	D	D	D	D	D	D	D	D	D											
470pF (471)	E	E	E	E	S	S	S	S	X	D	D	D	D	D	D	D	D	D											
560pF (561)	E	E	E	E	S	S	S	S	X	D	D	D	D	D	D	D	D	D											
680pF (681)	E	E	E	E	S	S	S	S	X	D	D	D	D	D	D	D	D	D											
820pF (821)	E	E	E	E	S	S	S	S	X	D	D	D	D	D	D	D	D	D											
1,000pF (102)	E	E	E	E	S	S	S	S	X	D	D	D	D	D	D	D	D	D	C	C	C	C	C	C	D	D	D	D	
1,200pF (122)	E	E	E	E	S	S	S	S	X	D	D	D	D	D	D	D	D	D	C	C	C	C	C	C	D	D	D	D	
1,500pF (152)	E	E	E	E	S	S	S	S	X	D	D	D	D	D	D	D	D	D	C	C	C	C	C	C	D	D	D	D	
1,800pF (182)	E	E	E	E	S	S	S	S	X	D	D	D	D	D	D	D	D	D	C	C	C	C	C	C	D	D	D	D	
2,200pF (222)	E	E	E	E	S	S	S	S	X	D	D	D	D	D	D	D	D	D	C	C	C	C	C	C	D	D	D	D	
2,700pF (272)	E	E	E	E	S	S	S	S	X	D	D	D	D	D	D	D	D	D	C	C	C	C	C	C	D	D	D	D	
3,300pF (332)	E	E	E	E	S	S	S	S	X	D	D	D	D	D	D	D	D	D	C	C	C	C	C	C	D	D	D	D	
3,900pF (392)	E	E	E	E	S	S	S	S	X	D	D	D	D	D	D	D	D	D	C	C	C	C	C	C	D	D	D	D	
4,700pF (472)	E	E	E	E	S	S	S	S	X	D	D	D	D	D	D	D	D	D	C	C	C	C	C	C	D	D	D	D	
5,600pF (562)	E	E	E		S	S	S	S	X	D	D	D	D	D	D	D	D	D	C	C	C	C	C	C	D	D	D	D	
6,800pF (682)	E	E	E		S	S	S	S	X	D	D	D	D	D	D	D	D	D	C	C	C	C	C	C	D	D	D	D	
8,200pF (822)	E	E	E		S	S	S	S	X	D	D	D	D	D	D	D	D	D	C	C	C	C	C	C	D	D	D	D	
0.010μF (103)	E	E	E		S	S	S	S	X	D	D	D	D	D	D	D	D	D	C	C	C	C	C	C	D	D	D	D	
0.012μF (123)	E	E			S	S	S	S	X	D	D	D	D	D	D	D	D	D	C	C	C	C	C	C	D	D	D	D	
0.015μF (153)	E	E			S	S	S	S	X	D	D	D	D	D	D	D	D	D	C	C	C	C	C	C	D	D	D	D	
0.018μF (183)	E	E			S	S	S	S	X	D	D	D	D	D	D	D	D	D	C	C	C	C	C	C	D	D	D	D	
0.022μF (223)	E	E			S	S	S	S	X	D	D	D	D	D	D	D	D	D	C	C	C	C	C	C	D	D	D	D	
0.027μF (273)	E	E			S	S	S	S	X	D	D	D	D	D	D	D	D	D	C	C	C	C	C	C	D	D	D	D	
0.033μF (333)	E	E			S	S	S	S	X	D	D	D	D	D	D	D	D	D	G	C	C	C	C	C	D	D	D	D	
0.039μF (393)	E	E			S	S	S	S	X	D	D	D	D	D	D	D	D	D	G	C	C	C	C	C	D	D	D	D	
0.047μF (473)	E	E			S	S	S	S	X	D	D	D	D	D	D	D	D	D	G	C	C	C	C	C	D	D	D	D	
0.056μF (563)	E				S	S	S	S	X	D	D	D	D	D	D	D	D	D	G	C	C	C	C	C	D	D	D	D	
0.068μF (683)	E				S	S	S	S	X	D	D	D	D	D	D	D	D	D	G	C	C	C	C	G	D	D	D	D	
0.082μF (823)	E				S	S	S	S	X	D	D	D		D	D	D	D	D	G	C	C	C	C	G	D	D	D	D	
0.10μF (104)	E				S	S	S	S	X	D	D	D		D	D	D	D	D	G	C	C	C	C	G	D	D	D	D	
0.12μF (124)					S	S	X			D	D			D	D	D	D	D	C	C	C	C	G	D	D	D	D	D	
0.15μF (154)					S	X				D	D			C	C	C	G		C	C	C	D	M	D	D	D	D	K	
0.18μF (184)					S	X				D	D			C	C	C	G		C	C	C	D	M	D	D	D	D	K	
0.22μF (224)					S	X	X			D	D	I		C	C	C	G		C	C	C	D	M	D	D	D	D	K	
0.27μF (274)					X	X				I	I			C	C	D	G		C	C	C	G	M	D	D	D	D	K	
0.33μF (334)					X	X				I	I			C	C	D	G		C	C	C	G	M	D	D	D	D	K	
0.39μF (394)					X	X				I	I			J	J	P	G		C	C	C	M	M	D	D	D	D	K	
0.47μF (474)					X	X				I	I			J	J	P	G		C	C	C	M	M	D	D	D	D	K	
0.56μF (564)					X					I				J	J	P	P		D	D	D	M	M	D	D	D	D	K	
0.68μF (684)					X					I				J	J	P	P		D	D	D	K	M	D	D	D	D	K	
0.82μF (824)					X					I				J	J	P	P		D	D	D	K		D	D	D	D	K	
1.0μF (105)					X					I	I			J	J	P	P		D	D	D	K		D	D	D	D	K	
1.5μF (155)										I				J	J	P			K	G	M	M						K	
2.2μF (225)										I				J	P	P			K	G	M	M			M	M			
3.3μF (335)														P	P				K	G	M								
4.7μF (475)										I				P	P				K	K									
10μF (106)														P	P				K	M	M								
22μF (226)														P					M										
47μF (476)																													

1. The letter in cell is expressed the symbol of product thickness.
 2. 0805 size, Cap. 4.7uF_16V only, 0805 size, Cap. 0.22uF_100V only, 1210 size, Cap.22uF_10V only.
 3. For more information about products with special capacitance or other data, please contact WTC local representative.

■ CAPACITANCE RANGE (SH Series)

X7R Dielectric (0805 to 1812 Size, 500V~3000V)

DIELECTRIC		X7R																				
SIZE		0805			1206					1210				1808				1812				
RATED VOLTAGE (VDC)		500	630	1000	500	630	1000	1500	2000	500	630	1000	1500, 2000	500, 630	1000	1500 2000	2500 3000	500 630	1000	1500 2000	3000	
Capacitance	100pF (101)	D	D	D																		
	120pF (121)	D	D	D																		
	150pF (151)	D	D	D	D	D	D	D	D					D	D	D	D					
	180pF (181)	D	D	D	D	D	D	D	D					D	D	D	D					
	220pF (221)	D	D	D	D	D	D	D	D					D	D	D	D					
	270pF (271)	D	D	D	D	D	D	D	D					D	D	D	D		D	D	K	
	330pF (331)	D	D	D	D	D	D	D	D					D	D	D	K		D	D	K	
	390pF (391)	D	D	D	D	D	D	D	D					D	D	D	K		D	D	K	
	470pF (471)	D	D	D	D	D	D	D	D					D	D	D	K		D	D	K	
	560pF (561)	D	D	D	D	D	D	D	D					D	D	D	K		D	D	K	
	680pF (681)	D	D	D	D	D	D	D	D					D	D	D	K		D	D	K	
	820pF (821)	D	D	D	D	D	D	D	G	G				D	D	D	K		D	D	K	
	1,000pF (102)	D	D	D	D	D	D	D	G	G	D	D	D	M	D	D	K	K	D	D	D	K
	1,200pF (122)	D	D	D	D	D	D	D	G	G	D	D	D	M	D	D	K	K	D	D	D	K
	1,500pF (152)	D	D	D	D	D	D	D	G	G	D	D	D	M	D	D	K	K	D	D	D	K
	1,800pF (182)	D	D	D	D	D	D	D	G	G	D	D	D	M	D	D	K	K	D	D	D	M
	2,200pF (222)	D	D	D	D	D	D	D	G	G	D	D	D	M	D	D	K		D	D	D	M
	2,700pF (272)	D	D		D	D	D	D	G	G	D	D	D	M	D	D	K		D	D	D	M
	3,300pF (332)	D	D		D	D	D	D	G	G	D	D	D	M	D	D	K		D	D	K	M
	3,900pF (392)	D	D		D	D	D	D	G		D	D	G	M	D	D	K		D	D	K	M
	4,700pF (472)	D	D		D	D	D	D	G		D	D	G	M	D	D	K		D	D	K	M
	5,600pF (562)	D	D		D	D	D	D	G		D	D	G	M	K	K	K		D	D	M	M
	6,800pF (682)	D	D		D	D	D	D	G		D	D	G	M	K	K	K		D	D	M	M
	8,200pF (822)	D	D		D	D	D	D	G		D	D	G	M	K	K			D	D	M	
	0.010μF (103)	D	D		D	D	D	D	G		D	D	G		K	K			D	D	M	
	0.012μF (123)	D	D		D	D	D	D	G		D	D	G		K	K			D	K		
	0.015μF (153)	D	D		D	D	D	D	G		D	D	G		K	K			D	K		
	0.018μF (183)	D	D		D	D					D	D	G		K	K			D	M		
	0.022μF (223)	D	D		G	G					D	D	G		K	K			D	M		
	0.027μF (273)	D	D		G	G					G	G	G		K	K			D	M		
	0.033μF (333)	D	D		G	G					G	G	G		K	K			D	M		
	0.039μF (393)				G	G					G	G	K		K	K			D	M		
	0.047μF (473)				G	G					G	G	M		K	K			D	M		
	0.056μF (563)				G	G					G	G			K	K			K	M		
	0.068μF (683)										K	K			K				K	M		
0.082μF (823)										K	K			K				K	M			
0.10μF (104)										K	K							K	M			
0.12μF (124)																		M				
0.15μF (154)																		M				
0.18μF (184)																		M				
0.22μF (224)																		M				
0.27μF (274)																		M				
0.33μF (334)																		M				
0.39μF (394)																		M				
0.47μF (474)																		M				
0.56μF (564)																						
0.68μF (684)																						
0.82μF (824)																						
1.00μF (105)																						

1. The letter in cell is expressed the symbol of product thickness.
2. For more information about products with special capacitance or other data, please contact WTC local representative.

■ CAPACITANCE RANGE (SH Series)

NP0 Dielectric 1825 to 2225 Sizes

DIELECTRIC		NP0																	
SIZE		1825						2220						2225					
RATED VOLTAGE (VDC)		100	200	500	1000	2000	3000	100	200	500	1000	2000	3000	100	200	500	1000	2000	3000
Capacitance	10pF (100)	G	G	G	K	K	K	G	G	G	K	K	K	G	G	G	K	K	K
	12pF (120)	G	G	G	K	K	K	G	G	G	K	K	K	G	G	G	K	K	K
	15pF (150)	G	G	G	K	K	K	G	G	G	K	K	K	G	G	G	K	K	K
	18pF (180)	G	G	G	K	K	K	G	G	G	K	K	K	G	G	G	K	K	K
	22pF (220)	G	G	G	K	K	K	G	G	G	K	K	K	G	G	G	K	K	K
	27pF (270)	G	G	G	K	K	K	G	G	G	K	K	K	G	G	G	K	K	K
	33pF (330)	G	G	G	K	K	K	G	G	G	K	K	K	G	G	G	K	K	K
	39pF (390)	G	G	G	K	K	K	G	G	G	K	K	K	G	G	G	K	K	K
	47pF (470)	G	G	G	K	K	K	G	G	G	K	K	K	G	G	G	K	K	K
	56pF (560)	G	G	G	K	K	K	G	G	G	K	K	K	G	G	G	K	K	K
	68pF (680)	G	G	G	K	K	K	G	G	G	K	K	K	G	G	G	K	K	K
	82pF (820)	G	G	G	K	K	K	G	G	G	K	K	K	G	G	G	K	K	K
	100pF (101)	G	G	G	K	K	K	G	G	G	K	K	K	G	G	G	K	K	K
	120pF (121)	G	G	G	K	K	K	G	G	G	K	K	K	G	G	G	K	K	K
	150pF (151)	G	G	G	K	K	K	G	G	G	K	K	K	G	G	G	K	K	K
	180pF (181)	G	G	G	K	K	K	G	G	G	K	K	K	G	G	G	K	K	K
	220pF (221)	G	G	G	K	K	K	G	G	G	K	K	K	G	G	G	K	K	K
	270pF (271)	G	G	G	K	K	K	G	G	G	K	K	K	G	G	G	K	K	K
	330pF (331)	G	G	G	K	K	K	G	G	G	K	K	M	G	G	G	K	K	K
	390pF (391)	G	G	G	K	K	K	G	G	G	K	K	M	G	G	G	K	K	K
	470pF (471)	G	G	G	K	K	K	G	G	G	K	K	M	G	G	G	K	K	K
	560pF (561)	G	G	G	K	K	K	G	G	G	K	K	M	G	G	G	K	K	K
	680pF (681)	G	G	G	K	K	M	G	G	G	K	K	M	G	G	G	K	K	K
	820pF (821)	G	G	G	K	K	M	G	G	G	K	K	M	G	G	G	K	M	M
	1,000pF (102)	G	G	G	K	K	M	G	G	G	K	K	M	G	G	G	K	M	M
	1,200pF (122)	G	G	G	K	K		G	G	G	M	M	M	G	G	G	K	M	
	1,500pF (152)	G	G	G	K	M		G	G	G	M	M	M	G	G	G	K	M	
	1,800pF (182)	G	G	G	K	M		G	G	G	M	M		G	G	G	K	M	
	2,200pF (222)	G	G	G	K	M		G	G	G	M	M		G	G	G	K	M	
	2,700pF (272)	G	G	G	K	M		G	G	G	M	M		G	G	G	K	M	
	3,300pF (332)	G	G	G	K	M		G	G	G	M	M		G	G	G	K	M	
	3,900pF (392)	G	G	G	M	M		G	G	G	M	M		G	G	G	K	M	
	4,700pF (472)	G	G	G	M	M		G	G	G	M	M		G	G	G	K	M	
5,600pF (562)	G	G	G	M			G	G	G	M			G	G	G	M	M		
6,800pF (682)	G	G	G	M			G	G	G	M			G	G	G	M	M		
8,200pF (822)	G	G	G	M			G	G	G	M			G	G	G	M	M		
0.010μF (103)	G	G	G	M			G	G	G	M			G	G	G	M	M		
0.012μF (123)	G	G	G				G	G	G				G	G	G				
0.015μF (153)	G	G	G				G	G	G				G	G	G				
0.018μF (183)	G	G	G				G	G	G				G	G	G				
0.022μF (223)	G	G	G				G	G	G				G	G	G				
0.027μF (273)	G	G					G	G					G	G	G				
0.033μF (333)	G	G					G	K					G	G	G				
0.039μF (393)	G	K					G	K					G	K	K				
0.047μF (473)	G	K					G	M					G	K	K				
0.056μF (563)	K	M					K	M					G	M	M				
0.068μF (683)	K	M					K	M					K	M	M				
0.082μF (823)	M						M						K	M					
0.1μF (104)	M						M						M	M					
0.12μF (124)																			
0.18μF (184)																			
0.22μF (224)																			

1. The letter in cell is expressed the symbol of product thickness.
2. For more information about products with special capacitance or other data, please contact WTC local representative.

■ CAPACITANCE RANGE (SH Series)

X7R Dielectric 1825 to 2225 Sizes

DIELECTRIC		X7R																	
SIZE		1825						2220						2225					
RATED VOLTAGE (VDC)		250	500	630	1000	2000	3000	25 50	100	250	500 630 1000	1500	2000	3000	500	630	1000	1500 2000	3000
Capacitance	1,000pF (102)	K	K	K	K	K	K	K	K	K	K	K	K	K	K	K	K	K	K
	1,200pF (122)	K	K	K	K	K	K	K	K	K	K	K	K	K	K	K	K	K	K
	1,500pF (152)	K	K	K	K	K	K	K	K	K	K	K	K	K	K	K	K	K	K
	1,800pF (182)	K	K	K	K	K	K	K	K	K	K	K	K	K	K	K	K	K	K
	2,200pF (222)	K	K	K	K	K	K	K	K	K	K	K	K	K	K	K	K	K	K
	2,700pF (272)	K	K	K	K	K	K	K	K	K	K	K	K	K	K	K	K	K	K
	3,300pF (332)	K	K	K	K	K	K	K	K	K	K	K	K	K	K	K	K	K	K
	3,900pF (392)	K	K	K	K	K	K	K	K	K	K	K	K	K	K	K	K	K	K
	4,700pF (472)	K	K	K	K	K	K	K	K	K	K	K	K	K	K	K	K	K	K
	5,600pF (562)	K	K	K	K	K	M	K	K	K	K	K	K	K	K	K	K	K	M
	6,800pF (682)	K	K	K	K	K	M	K	K	K	K	K	K	M	K	K	K	K	M
	8,200pF (822)	K	K	K	K	K	M	K	K	K	K	K	M	M	K	K	K	K	M
	0.010μF (103)	K	K	K	K	K	M	K	K	K	K	K	M	M	K	K	K	K	M
	0.012μF (123)	K	K	K	K	M	U	K	K	K	K	K	M	U	K	K	K	M	M
	0.015μF (153)	K	K	K	K	M	U	K	K	K	K	K	M	U	K	K	K	M	M
	0.018μF (183)	K	K	K	K	M	U	K	K	K	K	K	U	U	K	K	K	M	U
	0.022μF (223)	K	K	K	K	M		K	K	K	K	K	U		K	K	K	M	
	0.027μF (273)	K	K	K	K	U		K	K	K	K	K	U		K	K	K	M	
	0.033μF (333)	K	K	K	K	U		K	K	K	K	K	U		K	K	K	M	
	0.039μF (393)	K	K	K	K	U		K	K	K	K	K	U		K	K	K	U	
	0.047μF (473)	K	K	K	K	U		K	K	K	K	K	U		K	K	K	U	
	0.056μF (563)	K	K	K	K			K	K	K	K	K	U		K	K	K	U	
	0.068μF (683)	K	K	K	K			K	K	K	K	M			K	K	K		
	0.082μF (823)	K	K	K	M			K	K	K	K	M			K	K	K		
	0.10μF (104)	K	K	K	M			K	K	K	K	M			K	K	M		
	0.12μF (124)	K	K	K				K	K	K	K	M			K	K	U		
	0.15μF (154)	K	K	K				K	K	K	K	U			K	K	U		
	0.18μF (184)	K	K	K				K	K	K	K	U			K	K	U		
	0.22μF (224)	K	K	K				K	K	K	K	U			K	K	U		
	0.27μF (274)	K	K	K				K	K	K	K				K	K			
	0.33μF (334)	K	K	K				K	K	K	K				K	K			
	0.39μF (394)	K	K	K				K	K	K	K				K	K			
0.47μF (474)	K	K	K				K	K	K	K				K	K				
0.56μF (564)	K	M	M				K	K	K					K	K				
0.68μF (684)	K						K	K	K										
0.82μF (824)	K						K	K	K										
1.0μF (105)	K						K	K	K										
1.5μF (155)							K	K	M										
2.2μF (225)							K	K	M										
3.3μF (335)							K	K											
4.7μF (475)							K	M											
6.8μF (685)							M	U											
10μF (106)							U	U											

1. The letter in cell is expressed the symbol of product thickness.
2. For more information about products with special capacitance or other data, please contact WTC local representative.

■ **FEATURES**

- * These products have no polarity.
- * Their electrostatic capacity temperature response is stable at 15% even in high temperature ranges (up to 150°C).
- * Larger capacity and smaller size (0402 size) with X8G/X8R characteristics

■ **GENERAL ELECTRICAL DATA**

Dielectric	X8G	X8R
Size	0402, 0603, 0805, 1206, 1210	
Capacitance	0.2pF to 0.015μF	100pF to 0.047μF
Capacitance tolerance*	Cap≤5pF: A (±0.05pF), B (±0.1pF), C (±0.25pF) 5pF<Cap<10pF: C (±0.25pF), D (±0.5pF) Cap≥10pF: F (±1%), G (±2%), J (±5%), K (±10%)	K (±10%), M (±20%)
Rated voltage (WVDC)	10V, 16V, 25V, 50V, 100V	
Q/DF*	Cap<30pF: Q≥400+20C Cap≥30pF: Q≥1000	DF≤5%
Insulation resistance at Ur**	10GΩ or RxC≥500Ω·F whichever is smaller	
Operating temperature	-55 to +150°C	
Capacitance characteristic	±30ppm/°C	±15%
Termination	Ni/Sn (lead-free termination)	

■ **EXPLANATION OF PART NUMBERS**

HT	21	R	103	K	500	C	T
Series HT=High Temperature	Size (Inch (mm)) 21=0805 (2012)	Dielectric R=X8R	Capacitance 103=10x10 ³ =10nF	Tolerance K=±10%	Rated voltage 500=50 VDC	Termination C=Cu/Ni/Sn	Packaging T=7" reeled

* Please refer to page 2 "How to order" for more information.

■ **CAPACITANCE RANGE**

X8R Dielectric 0402, 0603, 0805 Sizes

DIELECTRIC	X8R												
	0402				0603				0805				
	10	16	25	50	10	16	25	50	10	16	25	50	
SIZE													
RATED VOLTAGE (VDC)													
Capacitance	100pF (101)	N	N	N	N	S	S	S	S	D	D	D	D
	120pF (121)	N	N	N	N	S	S	S	S	D	D	D	D
	150pF (151)	N	N	N	N	S	S	S	S	D	D	D	D
	180pF (181)	N	N	N	N	S	S	S	S	D	D	D	D
	220pF (221)	N	N	N	N	S	S	S	S	D	D	D	D
	270pF (271)	N	N	N	N	S	S	S	S	D	D	D	D
	330pF (331)	N	N	N	N	S	S	S	S	D	D	D	D
	390pF (391)	N	N	N	N	S	S	S	S	D	D	D	D
	470pF (471)	N	N	N	N	S	S	S	S	D	D	D	D
	560pF (561)	N	N	N	N	S	S	S	S	D	D	D	D
	680pF (681)	N	N	N	N	S	S	S	S	D	D	D	D
	820pF (821)	N	N	N	N	S	S	S	S	D	D	D	D
	1,000pF (102)	N	N	N	N	S	S	S	S	D	D	D	D
	1,200pF (122)	N	N	N	N	S	S	S	S	D	D	D	D
	1,500pF (152)	N	N	N	N	S	S	S	S	D	D	D	D
	1,800pF (182)	N	N	N	N	S	S	S	S	D	D	D	D
	2,200pF (222)	N	N	N	N	S	S	S	S	D	D	D	D
	2,700pF (272)					S	S	S	S	D	D	D	D
	3,300pF (332)					S	S	S	S	D	D	D	D
	3,900pF (392)					S	S	S	S	D	D	D	D
	4,700pF (472)					S	S	S	S	D	D	D	D
	5,600pF (562)					S	S	S	S	D	D	D	D
	6,800pF (682)					S	S	S	S	D	D	D	D
	8,200pF (822)					S	S	S	S	D	D	D	D
	0.010μF (103)					S	S	S	S	D	D	D	D
	0.012μF (123)									D	D	D	D
	0.015μF (153)									D	D	D	D
	0.018μF (183)									D	D	D	D
	0.022μF (223)									D	D	D	D
	0.027μF (273)									D	D	D	D
0.033μF (333)									D	D	D	D	
0.039μF (393)									D	D	D	D	
0.047μF (473)									D	D	D	D	
0.056μF (563)													
0.068μF (683)													
0.082μF (823)													
0.10μF (104)													

1. The letter in cell is expressed the symbol of product thickness.
2. For more information about products with special capacitance or other data, please contact WTC local representative.

■ CAPACITANCE RANGE

X8G Dielectric

DIELECTRIC	X8G																		
	SIZE	0402				0603					0805					1206		1210	
	RATED VOLTAGE (VDC)	10	16	25	50	10	16	25	50	100	10	16	25	50	100	10 16 25	50 100	10 16 25	50
Capacitance	0.1pF (0R1)																		
	0.2pF (0R2)	N	N	N	N														
	0.3pF (0R3)	N	N	N	N														
	0.4pF (0R4)	N	N	N	N														
	0.5pF (0R5)	N	N	N	N	S	S	S	S	S	A	A	A	A	A				
	1.0pF (1R0)	N	N	N	N	S	S	S	S	S	A	A	A	A	A				
	1.2pF (1R2)	N	N	N	N	S	S	S	S	S	A	A	A	A	A	B	B		
	1.5pF (1R5)	N	N	N	N	S	S	S	S	S	A	A	A	A	A	B	B		
	1.8pF (1R8)	N	N	N	N	S	S	S	S	S	A	A	A	A	A	B	B		
	2.0pF (2R0)	N	N	N	N	S	S	S	S	S	A	A	A	A	A	B	B		
	2.2pF (2R2)	N	N	N	N	S	S	S	S	S	A	A	A	A	A	B	B		
	2.7pF (2R7)	N	N	N	N	S	S	S	S	S	A	A	A	A	A	B	B		
	3.0pF (3R0)	N	N	N	N	S	S	S	S	S	A	A	A	A	A	B	B		
	3.3pF (3R3)	N	N	N	N	S	S	S	S	S	A	A	A	A	A	B	B		
	3.9pF (3R9)	N	N	N	N	S	S	S	S	S	A	A	A	A	A	B	B		
	4.0pF (4R0)	N	N	N	N	S	S	S	S	S	A	A	A	A	A	B	B		
	4.7pF (4R7)	N	N	N	N	S	S	S	S	S	A	A	A	A	A	B	B		
	5.0pF (5R0)	N	N	N	N	S	S	S	S	S	A	A	A	A	A	B	B		
	5.6pF (5R6)	N	N	N	N	S	S	S	S	S	A	A	A	A	A	B	B		
	6.0pF (6R0)	N	N	N	N	S	S	S	S	S	A	A	A	A	A	B	B		
	6.8pF (6R8)	N	N	N	N	S	S	S	S	S	A	A	A	A	A	B	B		
	7.0pF (7R0)	N	N	N	N	S	S	S	S	S	A	A	A	A	A	B	B		
	8.0pF (8R0)	N	N	N	N	S	S	S	S	S	A	A	A	A	A	B	B		
	8.2pF (8R2)	N	N	N	N	S	S	S	S	S	A	A	A	A	A	B	B		
	9.0pF (9R0)	N	N	N	N	S	S	S	S	S	A	A	A	A	A	B	B		
	10pF (100)	N	N	N	N	S	S	S	S	S	A	A	A	A	A	B	B	C	C
	12pF (120)	N	N	N	N	S	S	S	S	S	A	A	A	A	A	B	B	C	C
	15pF (150)	N	N	N	N	S	S	S	S	S	A	A	A	A	A	B	B	C	C
	18pF (180)	N	N	N	N	S	S	S	S	S	A	A	A	A	A	B	B	C	C
	22pF (220)	N	N	N	N	S	S	S	S	S	A	A	A	A	A	B	B	C	C
	27pF (270)	N	N	N	N	S	S	S	S	S	A	A	A	A	A	B	B	C	C
	33pF (330)	N	N	N	N	S	S	S	S	S	A	A	A	A	A	B	B	C	C
	39pF (390)	N	N	N	N	S	S	S	S	S	A	A	A	A	A	B	B	C	C
	47pF (470)	N	N	N	N	S	S	S	S	S	A	A	A	A	A	B	B	C	C
	56pF (560)	N	N	N	N	S	S	S	S	S	A	A	A	A	A	B	B	C	C
	68pF (680)	N	N	N	N	S	S	S	S	S	A	A	A	A	A	B	B	C	C
	82pF (820)	N	N	N	N	S	S	S	S	S	A	A	A	A	A	B	B	C	C
	100pF (101)	N	N	N	N	S	S	S	S	S	A	A	A	A	A	B	B	C	C
	120pF (121)	N	N	N	N	S	S	S	S	S	A	A	A	A	A	B	B	C	C
	150pF (151)	N	N	N	N	S	S	S	S	S	A	A	A	A	A	B	B	C	C
	180pF (181)	N	N	N	N	S	S	S	S	S	A	A	A	A	A	B	B	C	C
	220pF (221)	N	N	N	N	S	S	S	S	S	A	A	A	A	A	B	B	C	C
	270pF (271)	N	N	N	N	S	S	S	S	S	A	A	A	A	A	B	B	C	C
	330pF (331)	N	N	N	N	S	S	S	S	S	A	A	A	A	A	B	B	C	C
	390pF (391)	N	N	N	N	S	S	S	S	S	B	B	B	B	B	B	B	C	C
	470pF (471)	N	N	N	N	S	S	S	S	S	B	B	B	B	B	B	B	C	C
	560pF (561)					S	S	S	S	S	B	B	B	B	B	B	B	C	C
	680pF (681)					S	S	S	S	S	B	B	B	B	B	B	B	C	C
	820pF (821)					S	S	S	S	S	B	B	B	B	B	B	B	C	C
	1,000pF (102)					S	S	S	S	S	B	B	B	B	B	B	B	C	C
1,200pF (122)					X	X	X	X		B	B	B	B	B	B	B	C	C	
1,500pF (152)					X	X	X	X		B	B	B	B	B	B	B	C	C	
1,800pF (182)					X	X	X	X		B	B	B	B	B	B	B	C	C	
2,200pF (222)					X	X	X	X		B	B	B	B	B	B	B	C	C	
2,700pF (272)					X	X	X	X		D	D	D	D	D	B	B	C	C	
3,300pF (332)					X	X	X	X		D	D	D	D	D	B	B	C	C	
3,900pF (392)										D	D	D	D	D	B	B	C	C	
4,700pF (472)										D	D	D	D	D	B	B	C	C	
5,600pF (562)										D	D	D	D		B	B	C	C	
6,800pF (682)										D	D	D	D		C	C	C	C	
8,200pF (822)										D	D	D	D		D	D	C	C	
0.010uF (103)										D	D	D	D		D	D	C	C	
0.012uF (123)																	D	D	
0.015uF (153)																	D	D	

1. The letter in cell is expressed the symbol of product thickness.

2. For more information about products with special capacitance or other data, please contact WTC local representative.

■ **FEATURES**

- * High voltage in a given case size.
- * Circuit open during product cracking.
- * High stability and reliability.

■ **GENERAL ELECTRICAL DATA**

Dielectric	X7R
Size	0805, 1206, 1210, 1812
Capacitance	100pF to 1μF
Capacitance tolerance	K (±10%), M (±20%)
Rated voltage (WVDC)	50V, 100V, 200V, 250V, 500V
DF(Tan δ)	≤2.5%
Insulation resistance at Ur	≥10GΩ or RxC≥500Q-F whichever is smaller
Dielectric strength	100V: ≥2.5 x WVDC 200V and 250V: ≥2 x WVDC 500V: ≥1.5 x WVDC
Operating temperature	-55 to +125°C
Capacitance characteristic	±15%
Termination	Ni/Sn (lead-free termination)

■ **EXPLANATION OF PART NUMBERS**

OP	32	B	103	K	201	C	I
Series	Size (Inch (mm))	Dielectric	Capacitance	Tolerance	Rated voltage	Termination	Packaging
OP=Open-mode	32=1210 (3225)	B=X7R	103=10x103=10nF	K=±10%	201=200 VDC	C=Cu/Ni/Sn	T=7" reeled

* Please refer to page 2 "How to order" for more information.

■ **INNER CONSTRUCTION OF OPEN-MODE DESIGN**

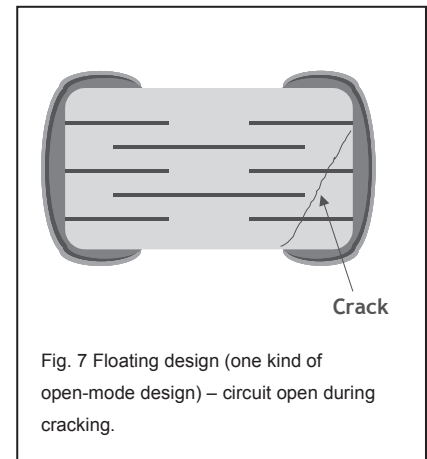
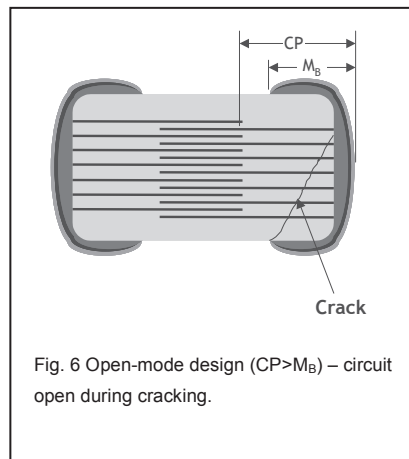
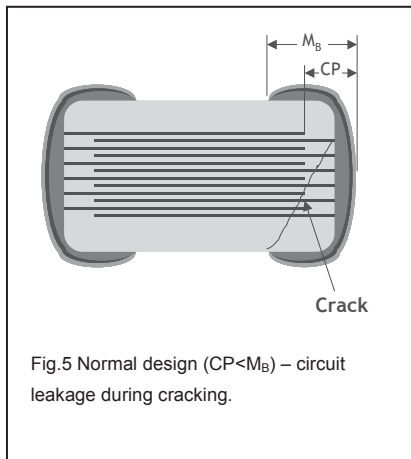

■ **CAPACITANCE RANGE**

DIELECTRIC		X7R																
SIZE		0805				1206					1210				1812			
RATED VOLTAGE (VDC)		100	200	250	500 630	50	100	200	250	500 630	100	200	250	500 630	100	200	250	500 630
Capacitance	100pF (101)	B	B	B	B													
	120pF (121)	B	B	B	B													
	150pF (151)	B	B	B	B	B	B	D	D	D								
	180pF (181)	B	B	B	B	B	B	D	D	D								
	220pF (221)	B	B	B	B	B	B	D	D	D								
	270pF (271)	B	B	B	B	B	B	D	D	D								
	330pF (331)	B	B	B	B	B	B	D	D	D								
	390pF (391)	B	B	B	B	B	B	D	D	D								
	470pF (471)	B	B	B	B	B	B	D	D	D								
	560pF (561)	B	B	B	B	B	B	D	D	D								
	680pF (681)	B	B	B	B	B	B	D	D	D								
	820pF (821)	B	B	B	B	B	B	D	D	D								
	1,000pF (102)	B	B	B	B	B	B	D	D	D	C	C	C	D	D	D	D	D
	1,200pF (122)	B	B	B	B	B	B	D	D	D	C	C	C	D	D	D	D	D
	1,500pF (152)	B	B	B	B	B	B	D	D	D	C	C	C	D	D	D	D	D
	1,800pF (182)	B	B	B	B	B	B	D	D	D	C	C	C	D	D	D	D	D
	2,200pF (222)	B	B	B	B	B	B	D	D	D	C	C	C	D	D	D	D	D
	2,700pF (272)	B	B	B	B	B	B	D	D	D	C	C	C	D	D	D	D	D
	3,300pF (332)	B	B	B	B	B	B	D	D	D	C	C	C	D	D	D	D	D
	3,900pF (392)	B	B	B	B	B	B	D	D	D	C	C	C	D	D	D	D	D
	4,700pF (472)	B	B	B	D	B	B	D	D	D	C	C	C	D	D	D	D	D
	5,600pF (562)	B	D	D	D	B	B	D	D	D	C	C	C	D	D	D	D	D
	6,800pF (682)	B	D	D	D	B	B	D	D	D	C	C	C	D	D	D	D	D
	8,200pF (822)	B	D	D	D	B	B	D	D	D	C	C	C	D	D	D	D	D
	0.010μF (103)	B	D	D	D	B	B	D	D	D	C	C	C	D	D	D	D	D
	0.012μF (123)	B	D	D		B	B	D	D	D	C	C	C	D	D	D	D	D
	0.015μF (153)	B	D	D		B	B	D	D	D	C	C	C	D	D	D	D	D
	0.018μF (183)	B	D	D		B	B	D	D	D	C	C	C	D	D	D	D	D
	0.022μF (223)	B	D	D		B	B	D	D	G	C	C	C	D	D	D	D	D
	0.027μF (273)	D				B	B	D	D	G	C	C	C	D	D	D	D	D
	0.033μF (333)	D				B	B	G	G	G	C	C	C	G	D	D	D	D
	0.039μF (393)	D				B	B	G	G		C	C	C	G	D	D	D	D
	0.047μF (473)	D				B	B	G	G		C	D	D	G	D	D	D	D
	0.056μF (563)					B	B	G	G		C	D	D	G	D	D	D	K
	0.068μF (683)					B	B	G	G		C	G	G	G	D	D	D	K
	0.082μF (823)					D	D	G	G		C	G	G		D	D	D	K
0.10μF (104)					D	D	G	G		C	G	G		D	D	D	K	
0.12μF (124)					D	D				C	G	G		D	D	D		
0.15μF (154)					D	G				D	M	M		D	K	K		
0.18μF (184)					D	G				D	M	M		D	K	K		
0.22μF (224)					D	G				D	M	M		D	K	K		
0.27μF (274)					D					G				D	K	K		
0.33μF (334)					D					G				D	K	K		
0.39μF (394)					D					M				D	K	K		
0.47μF (474)					D					M				K	K	K		
0.56μF (564)										M				K				
0.68μF (684)														K				
0.82μF (824)														K				
1.0μF (105)														K				

1. The letter in cell is expressed the symbol of product thickness.
2. For more information about products with special capacitance or other data, please contact WTC local representative.

■ **FEATURES**

- * High density mounting due to mounting space saving.
- * Mounting cost saving.
- * Increased throughput.

■ **GENERAL ELECTRICAL DATA**

Dielectric	NP0		X7R		Y5V
	4x0402	4x0603	4x0402	4x0603	4x0603
Size	4x0402	4x0603	4x0402	4x0603	4x0603
Capacitance*	10pF to 270pF	10pF to 470pF	1000pF to 100nF	180pF to 100nF	10nF to 100nF
Capacitance tolerance**	J (±5%), K (±10%)		K (±10%), M (±20%)		Z (-20/+80%)
Rated voltage (WVDC)	25,50V,100V	25, 50V,100V	10V, 16V, 25V, 50V	16V, 25V, 50V	16V, 50V
Q/DF(Tan δ)*	Cap<30pF: Q≥400+20C Cap≥30pF: Q≥1000		Ur=50V, ≤2.5% Ur=25V&16V, ≤3.5% Ur=10V, ≤5.0%		Ur=50V, ≤5% Ur=16V, ≤7%
Insulation resistance at Ur	≥10GΩ		≥10GΩ or RxC≥500ΩxF whichever is less		
Operating temperature	-55 to +125°C				-25 to +85°C
Capacitance characteristic	±30ppm		±15%		+30/-80%
Termination	Ni/Sn (lead-free termination)				

■ **EXPLANATION OF PART NUMBERS**

<u>Y</u>	<u>4C</u>	<u>3</u>	<u>B</u>	<u>103</u>	<u>K</u>	<u>500</u>	<u>C</u>	<u>I</u>
Series	Cap. Nr.	Termination pitch	Dielectric	Capacitance	Tolerance	Rated voltage	Termination	Packaging
Y=Capacitor array	4C=4xCap	3=0.03" pitch 2=0.02" pitch	B=X7R	103=10x10 ³ =10nF	K=±10%	500=50 VDC	C=Cu/Ni/Sn	T=7" reeled

* Please refer to page 2 "How to order" for more information.

■ **CAPACITANCE RANGE**

SIZE	4 x 0402					4 x 0603					
	NP0	X7R				NP0	X7R			Y5V	
RATED VOLTAGE (VDC)	25 50 100	10	16	25	50	25 50 100	16	25	50	16 25	50
Capacitance	10pF (100)	T				B					
	15pF (150)	T				B					
	22pF (220)	T				B					
	33pF (330)	T				B					
	47pF (470)	T				B					
	68pF (680)	T				B					
	100pF (101)	T				B					
	150pF (151)	T				B		B	B		
	180pF (181)	T				B		B	B		
	220pF (221)	T				B		B	B		
	270pF (271)	T				B		B	B		
	330pF (331)					B		B	B		
	470pF (471)					B		B	B		
	6.80pF (681)							B	B		
	1,000pF (102)		T	T	T	T		B	B		
	1,500pF (152)		T	T	T	T		B	B		
	2,200pF (222)		T	T	T	T		B	B		
	3,300pF (332)		T	T	T	T		B	B		
	4,700pF (472)		T	T	T	T		B	B		
	6,800pF (682)		T	T	T	T		B	B		
0.010μF (103)		T	T	T	T		B	B		B	
0.015μF (153)		T	T	T			B	B	B	B	
0.022μF (223)		T	T	T			B	B	B	B	
0.033μF (333)		T	T	T			B			B	
0.047μF (473)		T	T	T			B			B	
0.068μF (683)		T	T	T			B			B	
0.10μF (104)		T	T	T			B		B	B	

1. The letter in cell is expressed the symbol of product thickness.
2. For more information about products with special capacitance or other data, please contact WTC local representative.

■ **FEATURES**

- * Standard size with thin thickness.
- * Small size with high capacitance.
- * Capacitor with lead-free termination (pure Tin).

■ **GENERAL ELECTRICAL DATA**

Dielectric	X7R	X5R	Y5V
Size	0402, 0603, 0805, 1206, 1210		
Capacitance range	1.0μF to 10μF	0.22μF to 47μF	2.2μF to 10μF
Capacitance tolerance	K (±10%), M (±20%)		Z (-20/+80%)
Rated voltage (WVDC)	10V, 16V, 25V, 50V, 100V	6.3V, 10V, 16V, 25V	10V, 16V, 25V, 50V
DF(Tan δ)*	16V, 10V: ≤10.0% 6.3V: ≤15.0%		50V: ≤7% 25V: ≤9% 16V, 10V: ≤12.5%
Insulation resistance at Ur	RxC≥100ΩxF		
Operating temperature	-55 to +125°C	-55 to +85°C	-25 to +85°C
Capacitance characteristic	±15%		+30/-80%
Termination	Ni/Sn (lead-free termination)		

■ **EXPLANATION OF PART NUMBERS**

<u>TT</u>	<u>31</u>	<u>X</u>	<u>225</u>	<u>K</u>	<u>100</u>	<u>C</u>	<u>I</u>
<u>Series</u>	<u>Size (Inch (mm))</u>	<u>Dielectric</u>	<u>Capacitance</u>	<u>Tolerance</u>	<u>Rated voltage</u>	<u>Termination</u>	<u>Packaging</u>
TT=Low profile	31=1206 (3216)	X=X5R	225=22x10 ⁵ =2.2μF	K=±10%	100=10 VDC	C=Cu/Ni/Sn	T=7" reeled

* Please refer to page 2 "How to order" for more information.

■ **CAPACITANCE RANGE**

Dielectric		X5R																
Size		0402			0603			0805				1206				1210		
Rated voltage (VDC)		6.3	25	10	16	6.3	10	16	25	6.3	10	16	25	50	10	16	25	
Capacitance	0.22μF (224)		L	H	H													
	0.47μF (474)	L	L															
	1.0μF (105)	L		H	H		T	T	T		T	T	T					
	1.5μF (155)						T	T			T	T	T					
	2.2μF (225)	L				T	T	T	T		T	T	T					
	3.3μF (335)										T	T	T		T			
	4.7μF (475)			H		T	T	T	T		T	T	T		T			
	6.8μF (685)																	
	10μF (106)					T	T	T		J	T		T		T		T	
	22μF (226)					T	T			T		T				T		
47μF (476)									T									

Dielectric		X7R						Y5V									
Size		0805			1206			1210	0805				1206				1210
Rated voltage (VDC)		10	16, 25	10	25	50	100	10	16	25	50	10	16	25	50	10	
Capacitance	1.0μF (105)				T												
	1.5μF (155)																
	2.2μF (225)		T			T	K		T			T	T	T	T		
	3.3μF (335)							T									
	4.7μF (475)	T			T			T				T	T				
	6.8μF (685)											T					
	10μF (106)			T								T				T	
22μF (226)																	

1. The letter in cell is expressed the symbol of product thickness.
2. For more information about products with special capacitance or other data, please contact WTC local representative.

■ **FEATURES**

- * Standard size with thin thickness.
- * Small size with high capacitance.
- * Capacitor with lead-free termination (pure Tin).
- * MLCC with low ESL performance.

■ **GENERAL ELECTRICAL DATA**

Dielectric	X7R
Size	0612
Capacitance range	10nF to 150nF
Capacitance tolerance	K (±10%), M (±20%)
Rated voltage (WVDC)	50V
DF(Tan δ)*	≤2.5%
Insulation resistance at Ur	≥10GΩ or RxC≥500ΩxF whichever is less
Operating temperature	-55 to +125°C
Capacitance characteristic	±15%
Termination	Ni/Sn (lead-free termination)
ESL	500pH

■ **EXPLANATION OF PART NUMBERS**

<u>0612</u>	<u>B</u>	<u>103</u>	<u>K</u>	<u>500</u>	<u>C</u>	<u>I</u>
<u>Size (Inch (mm))</u>	<u>Dielectric</u>	<u>Capacitance</u>	<u>Tolerance</u>	<u>Rated voltage</u>	<u>Termination</u>	<u>Packaging</u>
0612 (1632)	B=X7R	103=10x10 ³ =10nF	K=±10%	500=50VDC	C=Cu/Ni/Sn	T=7" reeled

* Please refer to page 2 "How to order" for more information.

■ **CAPACITANCE RANGE**

DIELECTRIC		X7R
SIZE		0612
RATED VOLTAGE (VDC)		50
Capacitance	10nF (103)	B
	12nF (123)	B
	15nF (153)	B
	18nF (183)	B
	22nF (223)	B
	27nF (273)	B
	33nF (333)	B
	39nF (393)	B
	47nF (473)	B
	56nF (563)	B
	68nF (683)	B
	82nF (823)	B
	100nF (104)	B
	120nF (124)	B
150nF (154)	B	

1. The letter in cell is expressed the symbol of product thickness.
2. For more information about products with special capacitance or other data, please contact WTC local representative.

■ **FEATURES**

- * High voltage in a given case size.
- * High stability and reliability.
- * RoHS compliant.



■ **GENERAL ELECTRICAL DATA**

Dielectric	NP0	X7R
Size	1808, 1812, 2211	1808, 1812, 2220, 2211
Capacitance	3pF to 720pF	100pF to 4700pF
Capacitance tolerance	Cap.<10pF: D (±0.5pF) Cap.≥10pF: F (±1%), G (±2%), J (±5%), K (±10%)	K (±10%), M (±20%)
Rated voltage (WVAC)	250 Vac	
Q/ DF(Tan δ)	Cap<30pF: Q≥400+20C Cap≥30pF: Q≥1000	DF≤2.5%
Insulation resistance at Ur	≥10GΩ	
Peak impulse voltage	5000V, 6000V	
Operating temperature	-55 to +125°C	
Capacitance characteristic	±30ppm	±15%
Termination	Ni/Sn (lead-free termination)	
Certified number	TUV: R50195920, TUV: R50381780, UL: E182369	
Test standard	EN 60384-14 : 2013, IEC 60384-14 : 2013, UL 60384-14 (Ed 2.0)	

■ **EXPLANATION OF PART NUMBERS**

S2	42	N	100	J	502	C	I
Series S2=X1/Y2	Size (Inch (mm)) 42=1808 (4520)	Dielectric N=NP0	Capacitance 100=10x100 =10pF	Tolerance J=±5%	Rated voltage 502=5000V Impulse Voltage	Termination C=Cu/Ni/Sn	Packaging T=7" reeled

* Please refer to page 2 "How to order" for more information.

■ **CAPACITANCE RANGE**

DIELECTRIC	NP0			
	SIZE	1808	1812	2211
PEAK IMPULSE VOLTAGE	5000	5000	5000	6000
Capacitance	3.0pF (3R0)	F		
	4.0pF (4R0)	F		K
	5.0pF (5R0)	F		K
	6.0pF (6R0)	F		K
	7.0pF (7R0)	F		K
	8.0pF (8R0)	F		K
	10pF (100)	F	D	K
	12pF (120)	F	D	K
	15pF (150)	F	D	K
	18pF (180)	F	D	K
	22pF (220)	F	D	K
	27pF (270)	F	D	K
	33pF (330)	F	D	K
	39pF (390)	G	D	K
	47pF (470)	G	D	K
	56pF (560)	G	D	K
	68pF (680)	G	D	K
	82pF (820)	G	D	K
	100pF (101)	K	D	K
	120pF (121)	K	D	M
	150pF (151)	K	D	M
	180pF (181)	K	D	M
	220pF (221)	K	K	M
	270pF (271)	K	K	M
	330pF (331)		K	M
	390pF (391)		K	M
	470pF (471)		K	M
	560pF (561)			M
680pF (681)			M	
720pF (721)			M	

DIELECTRIC	X7R				
	SIZE	1808	1812	2211	2220
PEAK IMPULSE VOLTAGE	5000				
Capacitance	100pF (101)	G			
	120pF (121)	G			
	150pF (151)	G	G	G	
	180pF (181)	G	G	G	K
	220pF (221)	G	G	G	K
	270pF (271)	K	G	G	K
	330pF (331)	K	G	G	K
	390pF (391)	K	G	G	K
	470pF (471)	K	G	K	K
	560pF (561)	K	G	K	K
	680pF (681)	K	K	K	K
	820pF (821)	K	K	K	K
	1,000pF (102)	K	M	M	K
	1,200pF (122)			M	M
	1,500pF (152)			M	M
	1,800pF (182)			M	M
	2,200pF (222)			M	M
	3,300pF (332)				M
4,700pF (472)				M	

1. The letter in cell is expressed the symbol of product thickness.
2. For more information about products with special capacitance or other data, please contact WTC local representative.

■ **PACKAGING DIMENSION AND QUANTITY (X1/Y2 & X2 Series)**

Unit: pieces

Size Inch (mm)	L (mm)	W (mm)	M _B min(mm)	T (mm)/Symbol	7" Plastic tape
1808 (4520)	4.50±0.5/-0.3	2.03±0.25	0.50±0.25	1.40±0.15	F, 2,000
				1.60±0.20	G, 1,000
				2.00±0.20	K, 1,000
1812 (4532)	4.50±0.5/-0.3	3.20±0.30	0.50±0.25	1.60±0.20	G, 1,000
				2.00±0.20	K, 1,000
				2.50±0.30	M, 500
2220 (5750)	5.70±0.40	5.00±0.40	0.60±0.30	2.00±0.20	K, 1,000
				2.50±0.30	M, 500
				1.60±0.20	G, 1,000
2211 (5728)	5.70±0.40	2.80±0.30	0.60±0.30	2.00±0.20	K, 1,000
				2.50±0.30	M, 500

■ **FEATURES**

- * High voltage in a given case size.
- * High stability and reliability.
- * RoHS compliant.



■ **GENERAL ELECTRICAL DATA**

Dielectric	NP0	X7R
Size	1808, 1812, 2220	
Capacitance*	3.0pF to 1000pF	150pF to 0.022uF
Capacitance tolerance	Cap.<10pF: D (±0.5pF) Cap.≥10pF: F (±1%), G (±2%), J (±5%),	K (±10%), M (±20%)
Rated voltage (WVAC)	250 Vac	
Q/ DF(Tan δ)	Cap<30pF: Q≥400+20C Cap≥30pF: Q≥1000	Tan δ≤2.5%
Insulation resistance at Ur	≥10GΩ	
Peak impulse voltage (X2)	2500V	
Operating temperature	-55 to +125°C	
Capacitance characteristic	±30ppm	±15%
Termination	Ni/Sn (lead-free termination)	
Certified number	TUV: R50195920, TUV: R50381780, UL: E182369	
Test standard	EN 60384-14 : 2013, IEC 60384-14 : 2013, UL 60384-14 (Ed 2.0)	

■ **EXPLANATION OF PART NUMBERS**

S3	42	N	100	J	252	C	I
Series S3=X2	Size (Inch (mm)) 42=1808 (4520)	Dielectric N=NP0	Capacitance 100=10x100 =10pF	Tolerance J=±5%	Rated voltage 252=2500V Impulse Voltage	Termination C=Cu/Ni/Sn	Packaging T=7" reeled

* Please refer to page 2 "How to order" for more information.

■ **CAPACITANCE RANGE**

DIELECTRIC	NP0		
	1808	1812	
	SIZE	SIZE	
PEAK IMPULSE VOLTAGE	2500	2500	
Capacitance	3.0pF (3R0)	F	
	4.0pF (4R0)	F	
	5.0pF (5R0)	F	
	6.0pF (6R0)	F	
	7.0pF (7R0)	F	
	8.0pF (8R0)	F	
	9.0pF (9R0)	F	
	10pF (100)	F	D
	12pF (120)	F	D
	15pF (150)	F	D
	18pF (180)	F	D
	22pF (220)	F	D
	27pF (270)	F	D
	33pF (330)	F	D
	39pF (390)	G	D
	47pF (470)	G	D
	56pF (560)	G	D
	68pF (680)	G	D
	82pF (820)	G	D
	100pF (101)	K	D
	120pF (121)	K	D
	150pF (151)	K	D
	180pF (181)	K	D
	220pF (221)	K	D
	270pF (271)	K	D
	330pF (331)	K	D
390pF (391)	K	D	
470pF (471)	K	D	
560pF (561)	K	D	
680pF (681)	K	K	
820pF (821)	K	K	
1,000pF (102)	K	K	

DIELECTRIC	X7R			
	1808	1812	2220	
	SIZE	SIZE	SIZE	
PEAK IMPULSE VOLTAGE	2500	2500	2500	
Capacitance	150pF (151)	G		
	180pF (181)	G		
	220pF (221)	G		
	270pF (271)	G	G	
	330pF (331)	G	G	
	390pF (391)	G	G	
	470pF (471)	G	G	
	560pF (561)	G	G	
	680pF (681)	G	G	
	820pF (821)	G	G	
	1,000pF (102)	K	G	
	1,200pF (122)	K	G	
	1,500pF (152)	K	K	
	1,800pF (182)	K	K	
	2,200pF (222)	K	M	
	2,700pF (272)		M	
	3,300pF (332)		M	
	3,900pF (392)		M	
	4,700pF (472)		M	
	5,600pF (562)		M	
	0.010uF (103)			M
	0.015uF (153)			M
	0.018uF (183)			M
0.022uF (223)			U	

1. The letter in cell is expressed the symbol of product thickness.
2. For more information about products with special capacitance or other data, please contact WTC local representative.

■ GENERAL ELECTRICAL DATA

Dielectric	NP0	X7R
Size	0201, 0402, 0603, 0805, 1206, 1210	
Capacitance range	0.1pF to 0.015uF	100pF to 2.2uF
Capacitance tolerance	Cap≤5pF:B,C; 5pF<Cap<10pF:C,D; Cap≥10pF:F, G, J	J (±5%), K (±10%), M (±20%)
Rated voltage (WVDC)	10V, 16V, 25V, 50V, 100V, 250V, 500V, 630V, 1000V	
Operating temperature	-55 to +125°C	
Capacitance characteristic	±30ppm/°C	±15%
Termination	Ni/Sn (lead-free termination)	

■ EXPLANATION OF PART NUMBERS

MT	31	B	104	K	500	C	I
Series MT= Automotive (with AEC-Q200 qualification)	Size (Inch (mm)) 31=1206 (3216)	Dielectric B=X7R	Capacitance 104=10x10 ⁴ =0.1uF	Tolerance K=±10%	Rated voltage 500=50 VDC	Termination C=Cu/Ni/Sn	Packaging T=7" reeled

■ CAPACITANCE RANGE: NP0 Dielectric

Dielectric	NP0																				
	0201		0402			0603			0805			1206					1210				
Size	10 16 25 50	10 16 25 50	100	10 16 25 50	100	200 250	10 16 25 50	100	200 250	500 630	10 16 25 50	100	200	250	500 630	1000	10 16 25 50 100	200 250	500 630	1000	
Rated Voltage (VDC)	10 16 25 50	10 16 25 50	100	10 16 25 50	100	200 250	10 16 25 50	100	200 250	500 630	10 16 25 50	100	200	250	500 630	1000	10 16 25 50 100	200 250	500 630	1000	
0.2pF (0R2)	L	N	N																		
0.3pF (0R3)	L	N	N																		
0.4pF (0R4)	L	N	N																		
0.5pF (0R5)	L	N	N	S	S	S	A	A	A	A											
0.6pF (0R6)	L	N	N	S	S	S	A	A	A	A											
0.7pF (0R7)	L	N	N	S	S	S	A	A	A	A											
0.8pF (0R8)	L	N	N	S	S	S	A	A	A	A											
0.9pF (0R9)	L	N	N	S	S	S	A	A	A	A											
1.0pF (1R0)	L	N	N	S	S	S	A	A	A	A											
1.2pF (1R2)	L	N	N	S	S	S	A	A	A	A	B	B	B	B	B						
1.5pF (1R5)	L	N	N	S	S	S	A	A	A	A	B	B	B	B	B	B					
1.8pF (1R8)	L	N	N	S	S	S	A	A	A	A	B	B	B	B	B	B					
2.2pF (2R2)	L	N	N	S	S	S	A	A	A	A	B	B	B	B	B	B					
2.7pF (2R7)	L	N	N	S	S	S	A	A	A	A	B	B	B	B	B	B					
3.3pF (3R3)	L	N	N	S	S	S	A	A	A	A	B	B	B	B	B	B					
3.9pF (3R9)	L	N	N	S	S	S	A	A	A	A	B	B	B	B	B	B					
4.7pF (4R7)	L	N	N	S	S	S	A	A	A	A	B	B	B	B	B	B					
5.6pF (5R6)	L	N	N	S	S	S	A	A	A	A	B	B	B	B	B	B					
6.8pF (6R8)	L	N	N	S	S	S	A	A	A	A	B	B	B	B	B	B					
8.2pF (8R2)	L	N	N	S	S	S	A	A	A	A	B	B	B	B	B	B					
10pF (100)	L	N	N	S	S	S	A	A	A	A	B	B	B	B	B	B	C	C	C	C	C
12pF (120)	L	N	N	S	S	S	A	A	A	A	B	B	B	B	B	B	C	C	C	C	C
15pF (150)	L	N	N	S	S	S	A	A	A	A	B	B	B	B	B	B	C	C	C	C	C
18pF (180)	L	N	N	S	S	S	A	A	A	A	B	B	B	B	B	B	C	C	C	C	C
22pF (220)	L	N	N	S	S	S	A	A	A	A	B	B	B	B	B	B	D	C	C	C	C
27pF (270)	L	N	N	S	S	S	A	A	A	A	B	B	B	B	B	B	D	C	C	C	C
33pF (330)	L	N	N	S	S	S	A	A	A	A	B	B	B	B	B	B	D	C	C	C	C
39pF (390)	L	N	N	S	S	S	A	A	A	A	B	B	B	B	B	B	D	C	C	C	C
47pF (470)	L	N	N	S	S	S	A	A	A	A	B	B	B	B	B	B	D	C	C	C	C
56pF (560)	L	N	N	S	S	S	A	A	A	A	B	B	B	B	B	B	D	C	C	C	C
68pF (680)	L	N	N	S	S	S	A	A	A	A	B	B	B	B	B	B	D	C	C	C	C
82pF (820)	L	N	N	S	S	S	A	A	A	A	B	B	B	B	B	B	D	C	C	C	C
100pF (101)	L	N	N	S	S	S	A	A	B	B	B	B	B	B	B	B	D	C	C	C	D
120pF (121)		N	N	S	S	S	A	A	B	D	B	B	B	B	B	B	D	C	C	C	D
150pF (151)		N	N	S	S	S	A	A	D	D	B	B	B	B	B	B	D	C	C	C	D
180pF (181)		N	N	S	S	S	A	A	D	D	B	B	B	B	B	B	G	C	C	C	D
220pF (221)		N	N	S	S	S	A	A	D	D	B	B	B	B	B	B	G	C	C	C	G
270pF (271)		N	N	S	S	X	A	A	D	D	B	B	B	B	C	C	G	C	C	C	G
330pF (331)		N	N	S	S	X	A	A	D	D	B	B	B	B	C	C	G	C	C	C	G
390pF (391)		N	N	S	S	X	B	B	D	D	B	B	B	B	C	CC	G	C	C	C	G
470pF (471)		N	N	S	S	X	B	B	D	D	B	B	B	B	C	C	G	C	C	C	G
560pF (561)		N	N	S	S		B	B	D	D	B	B	C	D	D	G	C	C	C	C	G
680pF (681)		N	N	S	S		B	B	D	D	B	B	C	D	D	G	C	C	C	C	G
820pF (821)		N	N	S	S		B	B	D	D	B	B	C	D	D	G	C	C	C	C	G
1,000pF (102)		N	N	S	S		B	B	D	D	B	B	C	G	G	G	C	D	D	D	G
1,200pF (122)				X			B	B	D	D	B	B	C	G	G	G	C	D	D	D	
1,500pF (152)				X			B	B	D	D	B	B	D	G	G	G	C	D	D	D	
1,800pF (182)				X			B	B	D	D	B	B	D	G	G	G	C	D	D	D	
2,200pF (222)				X			B	B	D	D	B	B	D	G	G	G	C	D	D	D	
2,700pF (272)				X			D	D	D	D	B	B	D	G	G	G	C	D	D	D	
3,300pF (332)				X			D	D	D	D	B	B	D	G	G	G	C	D	D	D	
3,900pF (392)							D	D	D	D	B	B	D	G	G	G	C	D	D	D	
4,700pF (472)							D	D	D	D	B	B	D	G	G	G	C	D	D	D	
5,600pF (562)							D	D	D	D	B	B					C	D	D	D	
6,800pF (682)							D	D	D	D	C	C					C	D	D	D	
8,200pF (822)							D	D	D	D	D	D					C	D	D	D	
0.010uF (103)							D				D	D					C	D	D	D	
0.012uF (123)																	D	D	D	D	
0.015uF (153)																	D	D	D	D	
0.018uF (183)																	D	D	D	D	

1. The letter in cell is expressed the symbol of product thickness.
2. For more information about products with special capacitance or other data, please contact WTC local representative.

■ CAPACITANCE RANGE: X7R Dielectric

Dielectric		X7R																						
Size		0201			0402	0603			0805				1206				1210							
Rated Voltage (VDC)	Size	10	16 25	50	10 16 25 50	10 16 25	50	100	10 16 25	50	100	200 250	500 630	10 16	25	50	100	200 250	500 630	10 16 25 50	100	200 250	500	1000
		100pF (101)	L	L	L	N	S	S	S	B	B	B	B	B						D	D			D
120pF (121)	L	L	L	N	S	S	S	B	B	B	B	B						D	D			D	D	D
150pF (151)	L	L	L	N	S	S	S	B	B	B	B	B	B	B	B	B	B	D	D			D	D	D
180pF (181)	L	L	L	N	S	S	S	B	B	B	B	B	B	B	B	B	B	D	D			D	D	D
220pF (221)	L	L	L	N	S	S	S	B	B	B	B	B	B	B	B	B	B	D	D			D	D	D
270pF (271)	L	L	L	N	S	S	S	B	B	B	B	B	B	B	B	B	B	D	D			D	D	D
330pF (331)	L	L	L	N	S	S	S	B	B	B	B	B	B	B	B	B	B	D	D			D	D	D
390pF (391)	L	L	L	N	S	S	S	B	B	B	B	B	B	B	B	B	B	D	D			D	D	D
470pF (471)	L	L	L	N	S	S	S	B	B	B	B	B	B	B	B	B	B	D	D			D	D	D
560pF (561)	L	L	L	N	S	S	S	B	B	B	B	B	B	B	B	B	B	D	D			D	D	D
680pF (681)	L	L	L	N	S	S	S	B	B	B	B	B	B	B	B	B	B	D	D			C	D	D
820pF (821)	L	L	L	N	S	S	S	B	B	B	B	B	B	B	B	B	B	D	D			C	D	D
1,000pF (102)	L	L	L	N	S	S	S	B	B	B	B	B	B	B	B	B	B	D	D	C	C	C	D	D
1,200pF (122)	L	L		N	S	S	S	B	B	B	B	B	B	B	B	B	B	D	D	C	C	C	D	D
1,500pF (152)	L	L		N	S	S	S	B	B	B	B	B	B	B	B	B	B	D	D	C	C	C	D	D
1,800pF (182)	L	L		N	S	S	S	B	B	B	B	B	B	B	B	B	B	D	D	C	C	C	D	D
2,200pF (222)	L	L		N	S	S	S	B	B	B	B	B	B	B	B	B	B	D	D	C	C	C	D	D
2,700pF (272)	L	L		N	S	S	S	B	B	B	B	B	B	B	B	B	B	D	D	C	C	C	D	D
3,300pF (332)	L	L		N	S	S	S	B	B	B	B	B	B	B	B	B	B	D	D	C	C	C	D	D
3,900pF (392)	L	L		N	S	S	S	B	B	B	B	B	B	B	B	B	B	D	D	C	C	C	D	G
4,700pF (472)	L	L		N	S	S	S	B	B	B	B	D	B	B	B	B	B	D	D	C	C	C	D	G
5,600pF (562)	L	L		N	S	S	S	B	B	B	B	D	B	B	B	B	B	D	D	C	C	C	D	G
6,800pF (682)	L			N	S	S	S	B	B	B	B	D	B	B	B	B	B	D	D	C	C	C	D	G
8,200pF (822)	L			N	S	S	S	B	B	B	B	D	B	B	B	B	B	D	D	C	C	C	D	G
0.010uF (103)	L			N	S	S	S	B	B	B	D	D	B	B	B	B	B	D	D	C	C	C	D	G
0.012uF (123)					S	S		B	B	B	D		B	B	B	B	B	D		C	C	C	D	
0.015uF (153)					S	S		B	B	B	D		B	B	B	B	B	D		C	C	C	D	
0.018uF (183)					S	S		B	B	B	D		B	B	B	B	B	D		C	C	C	D	
0.022uF (223)					S	S		B	B	B	D		B	B	B	B	B	D		C	C	C	D	
0.027uF (273)					S	S		B	B	D			B	B	B	B				C	C	C		
0.033uF (333)					S	X		B	B	D			B	B	B	B				C	C	C		
0.039uF (393)					S	X		B	B	D			B	B	B	B				C	C	C		
0.047uF (473)					S	X		B	B	D			B	B	B	B				C	C	D		
0.056uF (563)					S	X		B	B	D			B	B	B	B				C	C			
0.068uF (683)					S	X		B	B	D			B	B	B	B				C	C			
0.082uF (823)					S	X		B	B	D			B	B	B	D				C	C			
0.10uF (104)					S	X		B	B	D			B	B	B	D				C	C			
0.12uF (124)								B	D				B	B	B	D				C				
0.15uF (154)								D	D				C	C	C	G				C				
0.18uF (184)								D	D				C	C	C	G				C				
0.22uF (224)								D	D				C	C	C	G				C				
0.27uF (274)								D					C	C	D					C				
0.33uF (334)								D					C	C	D					C				
0.39uF (394)								D					C	J	P					C				
0.47uF (474)								D					J	J	P					C				
0.56uF (564)								D					J	J	P					D				
0.68uF (684)								D					J	J	P					D				
0.82uF (824)								D					J	J	P					D				
1.0uF (105)													J	J	P					D				
1.5uF (155)																				K				
2.2uF (225)																				K				

1. The letter in cell is expressed the symbol of product thickness.
2. For more information about products with special capacitance or other data, please contact WTC local representative.

■ **FEATURES**

- * A wide selection of sizes is available (0402 to 1812).
- * High capacitance in given case size.
- * Capacitor with lead-free termination (pure Tin).
- * High reliability design with severe quality controls.

■ **GENERAL ELECTRICAL DATA**

Dielectric	NP0	X7R	X5R
Size	0201, 0402, 0603, 0805, 1206, 1210, 1812		
Capacitance range*	0.1pF to 0.033μF	100pF to 2.2μF	0.056μF to 10μF
Capacitance tolerance**	J (±5%), K (±10%), M (±20%) Cap≤5pF: B (±0.1pF), C (±0.25pF) 5pF<Cap<10pF: C (±0.25pF), D (±0.5pF) Cap≥10pF: F (±1%), G (±2%), J (±5%)		
Rated voltage (WVDC)	6.3V, 10V, 16V, 25V, 50V, 100V, 200V, 250V, 500V, 630, 1000V		6.3V, 10V, 16V, 25V
Operating temperature	-55 to +125°C		-55 to +85°C
Capacitance characteristic	±30ppm/°C	±15%	
Termination	Ni/Sn (lead-free termination)		

■ **EXPLANATION OF PART NUMBERS**

MT	31	B	104	K	500	C	I
Series	Size (Inch (mm))	Dielectric	Capacitance	Tolerance	Rated voltage	Termination	Packaging
MG= Automotive (without AEC-Q200 certification)	31=1206 (3216)	B=X7R	104=10x10 ⁴ =0.1uF	K=±10%	500=50 VDC	C=Cu/Ni/Sn	T=7" reeled

* Please refer to page 2 "How to order" for more information.

■ **CAPACITANCE RANGE**

X5R Dielectric

Dielectric	X5R																	
	0402			0603				0805				1206				1210		
	6.3	10	16	6.3	10	16	25	6.3	10	16	25	6.3	10	16	25	10	16	
Capacitance	0.056μF (563)	N																
	0.068μF (683)	N																
	0.082μF (823)	N																
	0.10μF (104)	N	N															
	0.15μF (154)	N	N															
	0.22μF (224)	N	N	N				X										
	0.27μF (274)	N	N			X	X	X										
	0.33μF (334)	N	N			X	X	X										
	0.39μF (394)	N				X	X	X										
	0.47μF (474)	N				X	X	X										
	0.68μF (684)	N				X	X	X										
	0.82μF (824)	N			X	X	X	X										
	1.0μF (105)				X	X	X	X										
	1.5μF (155)								I	I				J	J	P	K	K
	2.2μF (225)								I	I	I	I		J	J	P	K	K
	3.3μF (335)										I	I	P	P	P	P	K	K
4.7μF (475)										I	I	P	P	P	P	K	K	
6.8μF (685)												P	P					
10μF (106)												P						

1. The letter in cell is expressed the symbol of product thickness.
2. For more information about products with special capacitance or other data, please contact WTC local representative.

NP0 Dielectric

Dielectric		NP0																								
Size		0201			0402			0603			0805				1206					1210				1812		
Rated Voltage (VDC)		10 16 25 50	10 16 25 50	100	10 16 25 50	100	200 250	10 16 25 50	100	200	250	500 630	10 16 25 50	100	200	250	500 630	1000	10 16 25 50 100	200 250	500 630	1000	10 16 25 50	100		
Capacitance	0.1pF (0R1)	L	N	N																						
	0.2pF (0R2)	L	N	N																						
	0.3pF (0R3)	L	N	N																						
	0.4pF (0R4)	L	N	N																						
	0.5pF (0R5)	L	N	N	S	S	S	A	A	A	A	A														
	0.6pF (0R6)	L	N	N	S	S	S	A	A	A	A	A														
	0.7pF (0R7)	L	N	N	S	S	S	A	A	A	A	A														
	0.8pF (0R8)	L	N	N	S	S	S	A	A	A	A	A														
	0.9pF (0R9)	L	N	N	S	S	S	A	A	A	A	A														
	1.0pF (1R0)	L	N	N	S	S	S	A	A	A	A	A														
	1.2pF (1R2)	L	N	N	S	S	S	A	A	A	A	A	B	B	B	B	B									
	1.5pF (1R5)	L	N	N	S	S	S	A	A	A	A	A	B	B	B	B	B	B								
	1.8pF (1R8)	L	N	N	S	S	S	A	A	A	A	A	B	B	B	B	B	B								
	2.2pF (2R2)	L	N	N	S	S	S	A	A	A	A	A	B	B	B	B	B	B								
	2.7pF (2R7)	L	N	N	S	S	S	A	A	A	A	A	B	B	B	B	B	B								
	3.3pF (3R3)	L	N	N	S	S	S	A	A	A	A	A	B	B	B	B	B	B								
	3.9pF (3R9)	L	N	N	S	S	S	A	A	A	A	A	B	B	B	B	B	B								
	4.7pF (4R7)	L	N	N	S	S	S	A	A	A	A	A	B	B	B	B	B	B								
	5.6pF (5R6)	L	N	N	S	S	S	A	A	A	A	A	B	B	B	B	B	B								
	6.8pF (6R8)	L	N	N	S	S	S	A	A	A	A	A	B	B	B	B	B	B								
	8.2pF (8R2)	L	N	N	S	S	S	A	A	A	A	A	B	B	B	B	B	B								
	10pF (100)	L	N	N	S	S	S	A	A	A	A	A	B	B	B	B	B	B	C	C	C	C		D	D	
	12pF (120)	L	N	N	S	S	S	A	A	A	A	A	B	B	B	B	B	B	C	C	C	C		D	D	
	15pF (150)	L	N	N	S	S	S	A	A	A	A	A	B	B	B	B	B	B	C	C	C	C		D	D	
	18pF (180)	L	N	N	S	S	S	A	A	A	A	A	B	B	B	B	B	B	C	C	C	C		D	D	
	22pF (220)	L	N	N	S	S	S	A	A	A	A	A	B	B	B	B	B	D	C	C	C	C		D	D	
	27pF (270)	L	N	N	S	S	S	A	A	A	A	A	B	B	B	B	B	D	C	C	C	C		D	D	
	33pF (330)	L	N	N	S	S	S	A	A	A	A	A	B	B	B	B	B	D	C	C	C	C		D	D	
	39pF (390)	L	N	N	S	S	S	A	A	A	A	A	B	B	B	B	B	D	C	C	C	C		D	D	
	47pF (470)	L	N	N	S	S	S	A	A	A	A	A	B	B	B	B	B	D	C	C	C	C		D	D	
	56pF (560)	L	N	N	S	S	S	A	A	A	A	A	B	B	B	B	B	D	C	C	C	C		D	D	
	68pF (680)	L	N	N	S	S	S	A	A	A	A	A	B	B	B	B	B	D	C	C	C	C		D	D	
	82pF (820)	L	N	N	S	S	S	A	A	A	A	B	B	B	B	B	B	D	C	C	C	C		D	D	
	100pF (101)	L	N	N	S	S	S	A	A	A	B	B	B	B	B	B	B	D	C	C	C	D		D	D	
	120pF (121)		N	N	S	S	S	A	A	A	B	D	B	B	B	B	B	D	C	C	C	D		D	D	
	150pF (151)		N	N	S	S	S	A	A	B	D	D	B	B	B	B	B	D	C	C	C	D		D	D	
	180pF (181)		N	N	S	S	S	A	A	B	D	D	B	B	B	B	B	G	C	C	C	D		D	D	
	220pF (221)		N	N	S	S	S	A	A	D	D	D	B	B	B	B	B	G	C	C	C	G		D	D	
	270pF (271)		N		S	S	X	A	A	D	D	D	B	B	B	C	C	G	C	C	C	G		D	D	
	330pF (331)		N		S	S	X	A	A	D	D	D	B	B	B	C	C	G	C	C	C	G		D	D	
390pF (391)		N		S	S	X	B	B	D	D	D	B	B	B	C	CC	G	C	C	C	G		D	D		
470pF (471)		N		S	S	X	B	B	D	D		B	B	C	C	C	G	C	C	C	G		D	D		
560pF (561)		N		S	S		B	B	D	D		B	B	C	D	D	G	C	C	C	G		D	D		
680pF (681)		N		S	S		B	B	D	D		B	B	C	D	D	G	C	C	C	G		D	D		
820pF (821)		N		S	S		B	B	D	D		B	B	C	G	G	G	C	C	C	G		D	D		
1,000pF (102)		N		S	S		B	B	D	D		B	B	C	G	G	G	C	D	D	G		D	D		
1,200pF (122)				X			B	B	D	D		B	B	C	G	G		C	D	D			D	D		
1,500pF (152)				X			B	B	D	D		B	B	D	G	G		C	D	D			D	D		
1,800pF (182)				X			B	B	D	D		B	B	D	G	G		C	D	D			D	D		
2,200pF (222)				X			B	B	D	D		B	B	D	G	G		C	D	D			D	D		
2,700pF (272)				X			D	D				B	B	D	G			C	D	D			D	D		
3,300pF (332)				X			D	D				B	B	D	G			C	D	D			D	D		
3,900pF (392)							D	D				B	B	D	G			C	D	D			D	D		
4,700pF (472)							D	D				B	B	D	G			C	G				D	D		
5,600pF (562)							D	D				B	B					C	G				D	D		
6,800pF (682)							D	D				C	C					C	G				D	D		
8,200pF (822)							D	D				D	D					C	G				D	D		
0.010uF (103)							D					D	D					C	G				D	D		
0.012uF (123)																		C					D	D		
0.015uF (153)																		C					D	D		
0.018uF (183)																		K					D	D		
0.022uF (223)																		K					D	D		
0.027uF (273)																		K					D	D		
0.033uF (333)																		K					D	D		

1. The letter in cell is expressed the symbol of product thickness.
2. For more information about products with special capacitance or other data, please contact WTC local representative.

No.	Item	Test Condition	Requirements																																																																																										
1.	Visual and Mechanical	---	* No remarkable defect. * Dimensions to conform to individual specification sheet.																																																																																										
2.	Capacitance	Class I: (NP0,X8G) ≤ 1000pF, 1.0±0.2Vrms, 1MHz±10% > 1000pF, 1.0±0.2Vrms, 1KHz±10%	* Shall not exceed the limits given in the detailed spec.																																																																																										
3.	Q/ D.F. (Dissipation Factor)	Class II: (X7R, X7E, X6S, X5R,X7S, Y5V, X8R) C≤10μF, 1.0±0.2Vrms, 1KHz±10% ** C > 10μF, 0.5±0.2Vrms, 120Hz±20% ** Test condition: 0.5±0.2Vrms, 1KHz±10% X7R: 0805=106(6.3V), 0603/475(6.3V) X5R: 01R5(≤6.3V), 0201±224 (6.3V,10V,16V)#1, 0402±475 (6.3V,16V), 0402±225(10V), 0603=106 (6.3V,10V), TT18X±475(10V), TT15X series X6S: 0201±104 (6.3V, 10V#1), 0402±225 (6.3V), 0402/475 (10V), 0603/106 (6.3V), X7S: 0402/225(6.3V) #1 Excluding X5R/0201/105(6.3V); 225(10V) , X6S/0201/104(10V) (1.0±0.2Vrms, 1KHz±10%) * Before initial measurement (Class II only): To apply de-aging at 150°C for 1hr then set for 24±2 hrs at room condition**.	NP0, X8G: Cap≥30pF, Q≥1000; Cap<30pF,Q≥400+20C#2 #2.RF15(≥100V), RF18, RF21, RF11,RF22: Cap<30pF;Q≥800+20C;Cap≥30pF;Q≥1400 X8R: D.F. ≤5% X7R, X6S, X5R, X7S: <table border="1"> <thead> <tr> <th>Rated vol.</th> <th>D.F. ≤</th> <th colspan="2">Exception of D.F. ≤</th> </tr> </thead> <tbody> <tr> <td rowspan="3">≥100V</td> <td rowspan="3">≤2.5%</td> <td>≤3%</td> <td>1206≥0.47μF</td> </tr> <tr> <td>≤5%</td> <td>0805>0.1μF; 0603≥0.068μF; 1206>1μF; 1210≥2.2μF; TT series</td> </tr> <tr> <td>≤10%</td> <td>0805>0.22μF; 1210≥3.3μF</td> </tr> <tr> <td rowspan="3">50V</td> <td rowspan="3">≤2.5%</td> <td>≤3%</td> <td>0201(50V); 0603≥0.047μF; 0805≥0.18μF; 1206≥0.47μF</td> </tr> <tr> <td>≤5%</td> <td>0201≥0.01μF; 1210≥4.7μF</td> </tr> <tr> <td>≤10%</td> <td>0402≥0.012μF; 0603>0.1μF; 0805≥1μF; 1206≥2.2μF; 1210≥10μF; TT series</td> </tr> <tr> <td>35V</td> <td>≤3.5%</td> <td>≤10%</td> <td>0603≥1μF; 0805≥2.2μF; 1206≥2.2μF; 1210≥10μF</td> </tr> <tr> <td rowspan="3">25V</td> <td rowspan="3">≤3.5%</td> <td>≤5%</td> <td>0201≥0.01μF; 0805≥1μF; 1210≥10μF</td> </tr> <tr> <td>≤7%</td> <td>0603≥0.33μF</td> </tr> <tr> <td>≤10%</td> <td>0201≥0.1μF; 0402≥0.10μF&(0402/X7R≥0.056μF); TT series 0603≥0.47μF; 0805≥2.2μF; 1206≥4.7μF; 1210≥22μF</td> </tr> <tr> <td rowspan="2">16V</td> <td rowspan="2">≤3.5%</td> <td>≤5%</td> <td>0201≥0.01μF; 0402≥0.033μF; 0603≥0.15μF; 0805≥0.68μF; 1206≥2.2μF; 1210≥4.7μF</td> </tr> <tr> <td>≤10%</td> <td>0201≥0.1μF(0201/X7R≥0.022μF); 0402≥0.22μF; 0603≥0.68μF; 0805≥2.2μF; 1206≥4.7μF; 1210≥22μF; TT series</td> </tr> <tr> <td>10V</td> <td>≤5%</td> <td>≤10%</td> <td>0201≥0.012μF; 0402≥0.33μF(0402/X7R≥0.22μF); TT series 0603≥0.33μF; 0805≥2.2μF; 1206≥2.2μF; 1210≥22μF;01R5/X5R</td> </tr> <tr> <td rowspan="2">6.3V</td> <td rowspan="2">≤10%</td> <td>≤15%</td> <td>0201≥0.1μF; 0402≥1μF; 0603≥10μF; 0805≥4.7μF; 1206≥47μF ;1210≥100μF; TT series</td> </tr> <tr> <td>≤20%</td> <td>0402≥2.2μF</td> </tr> <tr> <td>4V</td> <td>≤15%</td> <td>---</td> <td>---</td> </tr> </tbody> </table> <table border="1"> <thead> <tr> <th>Rated vol.</th> <th>D.F. ≤</th> <th colspan="2">Exception of D.F. ≤</th> </tr> </thead> <tbody> <tr> <td>≥50V</td> <td>≤5%</td> <td>≤7%</td> <td>0603≥0.1μF; 0805≥0.47μF; 1206≥4.7μF; TT series</td> </tr> <tr> <td rowspan="2">35V</td> <td rowspan="2">≤7%</td> <td>---</td> <td>---</td> </tr> <tr> <td>≤12.5%</td> <td>1210≥6.8μF</td> </tr> <tr> <td rowspan="2">25V</td> <td rowspan="2">≤5%</td> <td>≤7%</td> <td>0402≥0.047μF; 0603≥0.1μF; 0805≥0.33μF; 1206≥1μF; 1210≥4.7μF</td> </tr> <tr> <td>≤9%</td> <td>0402≥0.068μF; 0603≥0.47μF; 1206≥4.7μF; 1210≥22μF; TT series & Cap≥1μF</td> </tr> <tr> <td>16V (C<1.0μF)</td> <td>≤7%</td> <td>≤9%</td> <td>0402≥0.068μF; 0603≥0.68μF</td> </tr> <tr> <td rowspan="2">16V (C≥1.0μF)</td> <td rowspan="2">≤9%</td> <td>≤12.5%</td> <td>0402≥0.22μF</td> </tr> <tr> <td>≤12.5%</td> <td>0603≥2.2μF; 0805≥3.3μF; 1206≥10μF; 1210≥22μF; 1812≥47μF; TT series</td> </tr> <tr> <td>10V</td> <td>≤12.5%</td> <td>≤20%</td> <td>0402≥0.47μF</td> </tr> <tr> <td>6.3V</td> <td>≤20%</td> <td>---</td> <td>---</td> </tr> </tbody> </table>	Rated vol.	D.F. ≤	Exception of D.F. ≤		≥100V	≤2.5%	≤3%	1206≥0.47μF	≤5%	0805>0.1μF; 0603≥0.068μF; 1206>1μF; 1210≥2.2μF; TT series	≤10%	0805>0.22μF; 1210≥3.3μF	50V	≤2.5%	≤3%	0201(50V); 0603≥0.047μF; 0805≥0.18μF; 1206≥0.47μF	≤5%	0201≥0.01μF; 1210≥4.7μF	≤10%	0402≥0.012μF; 0603>0.1μF; 0805≥1μF; 1206≥2.2μF; 1210≥10μF; TT series	35V	≤3.5%	≤10%	0603≥1μF; 0805≥2.2μF; 1206≥2.2μF; 1210≥10μF	25V	≤3.5%	≤5%	0201≥0.01μF; 0805≥1μF; 1210≥10μF	≤7%	0603≥0.33μF	≤10%	0201≥0.1μF; 0402≥0.10μF&(0402/X7R≥0.056μF); TT series 0603≥0.47μF; 0805≥2.2μF; 1206≥4.7μF; 1210≥22μF	16V	≤3.5%	≤5%	0201≥0.01μF; 0402≥0.033μF; 0603≥0.15μF; 0805≥0.68μF; 1206≥2.2μF; 1210≥4.7μF	≤10%	0201≥0.1μF(0201/X7R≥0.022μF); 0402≥0.22μF; 0603≥0.68μF; 0805≥2.2μF; 1206≥4.7μF; 1210≥22μF; TT series	10V	≤5%	≤10%	0201≥0.012μF; 0402≥0.33μF(0402/X7R≥0.22μF); TT series 0603≥0.33μF; 0805≥2.2μF; 1206≥2.2μF; 1210≥22μF;01R5/X5R	6.3V	≤10%	≤15%	0201≥0.1μF; 0402≥1μF; 0603≥10μF; 0805≥4.7μF; 1206≥47μF ;1210≥100μF; TT series	≤20%	0402≥2.2μF	4V	≤15%	---	---	Rated vol.	D.F. ≤	Exception of D.F. ≤		≥50V	≤5%	≤7%	0603≥0.1μF; 0805≥0.47μF; 1206≥4.7μF; TT series	35V	≤7%	---	---	≤12.5%	1210≥6.8μF	25V	≤5%	≤7%	0402≥0.047μF; 0603≥0.1μF; 0805≥0.33μF; 1206≥1μF; 1210≥4.7μF	≤9%	0402≥0.068μF; 0603≥0.47μF; 1206≥4.7μF; 1210≥22μF; TT series & Cap≥1μF	16V (C<1.0μF)	≤7%	≤9%	0402≥0.068μF; 0603≥0.68μF	16V (C≥1.0μF)	≤9%	≤12.5%	0402≥0.22μF	≤12.5%	0603≥2.2μF; 0805≥3.3μF; 1206≥10μF; 1210≥22μF; 1812≥47μF; TT series	10V	≤12.5%	≤20%	0402≥0.47μF	6.3V	≤20%	---	---
Rated vol.	D.F. ≤	Exception of D.F. ≤																																																																																											
≥100V	≤2.5%	≤3%	1206≥0.47μF																																																																																										
		≤5%	0805>0.1μF; 0603≥0.068μF; 1206>1μF; 1210≥2.2μF; TT series																																																																																										
		≤10%	0805>0.22μF; 1210≥3.3μF																																																																																										
50V	≤2.5%	≤3%	0201(50V); 0603≥0.047μF; 0805≥0.18μF; 1206≥0.47μF																																																																																										
		≤5%	0201≥0.01μF; 1210≥4.7μF																																																																																										
		≤10%	0402≥0.012μF; 0603>0.1μF; 0805≥1μF; 1206≥2.2μF; 1210≥10μF; TT series																																																																																										
35V	≤3.5%	≤10%	0603≥1μF; 0805≥2.2μF; 1206≥2.2μF; 1210≥10μF																																																																																										
25V	≤3.5%	≤5%	0201≥0.01μF; 0805≥1μF; 1210≥10μF																																																																																										
		≤7%	0603≥0.33μF																																																																																										
		≤10%	0201≥0.1μF; 0402≥0.10μF&(0402/X7R≥0.056μF); TT series 0603≥0.47μF; 0805≥2.2μF; 1206≥4.7μF; 1210≥22μF																																																																																										
16V	≤3.5%	≤5%	0201≥0.01μF; 0402≥0.033μF; 0603≥0.15μF; 0805≥0.68μF; 1206≥2.2μF; 1210≥4.7μF																																																																																										
		≤10%	0201≥0.1μF(0201/X7R≥0.022μF); 0402≥0.22μF; 0603≥0.68μF; 0805≥2.2μF; 1206≥4.7μF; 1210≥22μF; TT series																																																																																										
10V	≤5%	≤10%	0201≥0.012μF; 0402≥0.33μF(0402/X7R≥0.22μF); TT series 0603≥0.33μF; 0805≥2.2μF; 1206≥2.2μF; 1210≥22μF;01R5/X5R																																																																																										
6.3V	≤10%	≤15%	0201≥0.1μF; 0402≥1μF; 0603≥10μF; 0805≥4.7μF; 1206≥47μF ;1210≥100μF; TT series																																																																																										
		≤20%	0402≥2.2μF																																																																																										
4V	≤15%	---	---																																																																																										
Rated vol.	D.F. ≤	Exception of D.F. ≤																																																																																											
≥50V	≤5%	≤7%	0603≥0.1μF; 0805≥0.47μF; 1206≥4.7μF; TT series																																																																																										
35V	≤7%	---	---																																																																																										
		≤12.5%	1210≥6.8μF																																																																																										
25V	≤5%	≤7%	0402≥0.047μF; 0603≥0.1μF; 0805≥0.33μF; 1206≥1μF; 1210≥4.7μF																																																																																										
		≤9%	0402≥0.068μF; 0603≥0.47μF; 1206≥4.7μF; 1210≥22μF; TT series & Cap≥1μF																																																																																										
16V (C<1.0μF)	≤7%	≤9%	0402≥0.068μF; 0603≥0.68μF																																																																																										
16V (C≥1.0μF)	≤9%	≤12.5%	0402≥0.22μF																																																																																										
		≤12.5%	0603≥2.2μF; 0805≥3.3μF; 1206≥10μF; 1210≥22μF; 1812≥47μF; TT series																																																																																										
10V	≤12.5%	≤20%	0402≥0.47μF																																																																																										
6.3V	≤20%	---	---																																																																																										
4a.	Dielectric Strength	*To apply voltage: ≤100V: 250% of rated voltage. 200V ~ 300V: 200% of rated voltage. 400V ~ 450V: 120% of rated voltage. 500V ~ 999V: 150% of rated voltage. 1000V ~ 3000V: 120% of rated voltage. 4000V: 110% of rated voltage. *Duration: 1 to 5 sec. *Charge & discharge current less than 50mA.	* No evidence of damage or flash over during test.																																																																																										
4b.	Dielectric Strength (for X1/Y2 & X2)	* To apply 1500 VAC voltage. * Duration: 60 sec.	* No evidence of damage or flash over during test.																																																																																										
5.	Insulation Resistance	To apply rated voltage for max. 120 sec. *Before initial measurement (Class II only): To apply de-aging at 150°C for 1hr then set for 24±2 hrs at room condition**.	10GΩ or RxC≥500Ω-F whichever is smaller. Class II (X7R, X6S, X5R, X7S,Y5V) <table border="1"> <thead> <tr> <th>Rated voltage</th> <th>Insulation Resistance</th> </tr> </thead> <tbody> <tr> <td>100V: X7R</td> <td rowspan="6">10GΩ or RxC≥100 Ω-F whichever is smaller.</td> </tr> <tr> <td>50V: 0402>0.01μF; 0603≥1μF;0805≥1μF; 1206≥4.7μF; 1210≥4.7μF</td> </tr> <tr> <td>35V: 0805≥2.2μF; 1206≥2.2μF; 1210≥10μF</td> </tr> <tr> <td>25V: 0402≥1μF; 0603≥2.2μF; 0805≥2.2μF; 1206≥10μF; 1210≥10μF</td> </tr> <tr> <td>16V: 0201≥0.1μF; 0402≥0.22μF; 0603≥1μF; 0805≥2.2μF; 1206≥10μF; 1210≥47μF</td> </tr> <tr> <td>10V: 0201≥47nF; 0402≥0.47μF; 0603≥0.47μF; 0805≥2.2μF; 1206≥4.7μF; 1210≥47μF</td> </tr> <tr> <td>6.3V: 4V; TT series; Size≥1812</td> <td rowspan="2">RxC≥50 Ω-F</td> </tr> <tr> <td>All X6S items, All X7S items, X5R/01R5</td> </tr> <tr> <td>100V: 1210≥3.3μF, 50V: 0402≥0.1μF; 0603≥2.2μF; 0805≥10μF;1206≥10μF / 35V: 0603≥1μF / 25V: 0201>0.1μF; 0402≥0.22μF; 0603≥10μF; 0805≥10μF;1206≥22μF / 16V: 0603≥10μF; 0402≥1μF; 0201≥0.22μF / 10V: 0201>0.1μF, 0402≥1μF; 0603≥10μF; 0805≥47μF; TT21>4.7μF / 6.3V: 0201≥0.1μF; 0603>4.7μF; 0805≥47μF;1206≥10μF; TT15>1.0μF / 4V:0603≥22μF; 0805≥47μF; 1206≥100μF</td> </tr> </tbody> </table> <table border="1"> <tbody> <tr> <td>Rated Voltage: 200V ~ 630V</td> <td>To apply rated voltage (500V max.) for 60 sec.</td> <td>>10GΩ or 100Ω-F whichever is smaller.</td> </tr> <tr> <td>Rated Voltage: >630V</td> <td>To apply 500V for 60sec.</td> <td>>10GΩ or 100Ω-F whichever is smaller.</td> </tr> </tbody> </table>	Rated voltage	Insulation Resistance	100V: X7R	10GΩ or RxC≥100 Ω-F whichever is smaller.	50V: 0402>0.01μF; 0603≥1μF;0805≥1μF; 1206≥4.7μF; 1210≥4.7μF	35V: 0805≥2.2μF; 1206≥2.2μF; 1210≥10μF	25V: 0402≥1μF; 0603≥2.2μF; 0805≥2.2μF; 1206≥10μF; 1210≥10μF	16V: 0201≥0.1μF; 0402≥0.22μF; 0603≥1μF; 0805≥2.2μF; 1206≥10μF; 1210≥47μF	10V: 0201≥47nF; 0402≥0.47μF; 0603≥0.47μF; 0805≥2.2μF; 1206≥4.7μF; 1210≥47μF	6.3V: 4V; TT series; Size≥1812	RxC≥50 Ω-F	All X6S items, All X7S items, X5R/01R5	100V: 1210≥3.3μF, 50V: 0402≥0.1μF; 0603≥2.2μF; 0805≥10μF;1206≥10μF / 35V: 0603≥1μF / 25V: 0201>0.1μF; 0402≥0.22μF; 0603≥10μF; 0805≥10μF;1206≥22μF / 16V: 0603≥10μF; 0402≥1μF; 0201≥0.22μF / 10V: 0201>0.1μF, 0402≥1μF; 0603≥10μF; 0805≥47μF; TT21>4.7μF / 6.3V: 0201≥0.1μF; 0603>4.7μF; 0805≥47μF;1206≥10μF; TT15>1.0μF / 4V:0603≥22μF; 0805≥47μF; 1206≥100μF	Rated Voltage: 200V ~ 630V	To apply rated voltage (500V max.) for 60 sec.	>10GΩ or 100Ω-F whichever is smaller.	Rated Voltage: >630V	To apply 500V for 60sec.	>10GΩ or 100Ω-F whichever is smaller.																																																																							
Rated voltage	Insulation Resistance																																																																																												
100V: X7R	10GΩ or RxC≥100 Ω-F whichever is smaller.																																																																																												
50V: 0402>0.01μF; 0603≥1μF;0805≥1μF; 1206≥4.7μF; 1210≥4.7μF																																																																																													
35V: 0805≥2.2μF; 1206≥2.2μF; 1210≥10μF																																																																																													
25V: 0402≥1μF; 0603≥2.2μF; 0805≥2.2μF; 1206≥10μF; 1210≥10μF																																																																																													
16V: 0201≥0.1μF; 0402≥0.22μF; 0603≥1μF; 0805≥2.2μF; 1206≥10μF; 1210≥47μF																																																																																													
10V: 0201≥47nF; 0402≥0.47μF; 0603≥0.47μF; 0805≥2.2μF; 1206≥4.7μF; 1210≥47μF																																																																																													
6.3V: 4V; TT series; Size≥1812	RxC≥50 Ω-F																																																																																												
All X6S items, All X7S items, X5R/01R5																																																																																													
100V: 1210≥3.3μF, 50V: 0402≥0.1μF; 0603≥2.2μF; 0805≥10μF;1206≥10μF / 35V: 0603≥1μF / 25V: 0201>0.1μF; 0402≥0.22μF; 0603≥10μF; 0805≥10μF;1206≥22μF / 16V: 0603≥10μF; 0402≥1μF; 0201≥0.22μF / 10V: 0201>0.1μF, 0402≥1μF; 0603≥10μF; 0805≥47μF; TT21>4.7μF / 6.3V: 0201≥0.1μF; 0603>4.7μF; 0805≥47μF;1206≥10μF; TT15>1.0μF / 4V:0603≥22μF; 0805≥47μF; 1206≥100μF																																																																																													
Rated Voltage: 200V ~ 630V	To apply rated voltage (500V max.) for 60 sec.	>10GΩ or 100Ω-F whichever is smaller.																																																																																											
Rated Voltage: >630V	To apply 500V for 60sec.	>10GΩ or 100Ω-F whichever is smaller.																																																																																											

** "Room condition" Temperature: 15 to 35°C, Relative humidity: 25 to 75%, Atmospheric pressure: 86 to 106kPa.

This Reliability Test Conditions and Requirements only for General Purpose series, please refer to individual sheet for other products information.

No.	Item	Test Condition	Requirements																																																														
6.	Temperature Coefficient	<p>With no electrical load.</p> <table border="1"> <thead> <tr> <th>T.C.</th> <th>Operating Temp</th> </tr> </thead> <tbody> <tr> <td>NPO (C0G)</td> <td>-55~125°C at 25°C</td> </tr> <tr> <td>X8G</td> <td>-55~150°C at 25°C</td> </tr> <tr> <td>X8R</td> <td>-55~150°C at 25°C</td> </tr> <tr> <td>X7R</td> <td>-55~125°C at 25°C</td> </tr> <tr> <td>X7S</td> <td>-55~125°C at 25°C</td> </tr> <tr> <td>X6S</td> <td>-55~105°C at 25°C</td> </tr> <tr> <td>X5R</td> <td>-55~85°C at 25°C</td> </tr> <tr> <td>Y5V</td> <td>-25~85°C at 20°C</td> </tr> </tbody> </table> <p>*Measurement voltage for Class II:</p> <table border="1"> <thead> <tr> <th>01005</th> <th>0201</th> </tr> </thead> <tbody> <tr> <td>Cap≤0.01μF: 0.5V</td> <td>Cap<0.1μF: 1V</td> </tr> <tr> <td>Cap>0.01μF: 0.2V</td> <td>0.1μF≤Cap<1μF: 0.2V</td> </tr> <tr> <td></td> <td>Cap≥1μF: 0.1V</td> </tr> <tr> <th>0402</th> <th>0603</th> </tr> <tr> <td>Cap<1μF: 1V</td> <td>Cap≤1μF: 1V</td> </tr> <tr> <td>Cap=1μF: 0.5V</td> <td>1μF<Cap≤4.7μF: 0.5V</td> </tr> <tr> <td>1μF<Cap<10μF: 0.2V</td> <td>Cap>4.7μF: 0.2V</td> </tr> <tr> <td>Cap≥10μF: 0.1V</td> <td></td> </tr> <tr> <th>0805</th> <th>1206/1210</th> </tr> <tr> <td>Cap<10μF: 1V</td> <td>Cap≤10μF: 1V</td> </tr> <tr> <td>Cap=10μF: 0.5V</td> <td>10μF<Cap≤100μF: 0.5V</td> </tr> <tr> <td>Cap>10μF: 0.2V</td> <td>Cap>100μF: 0.2V</td> </tr> </tbody> </table> <p>*Before initial measurement (Class II only): To apply de-aging at 150°C for 1hr then set for 24±2 hrs at room condition**.</p>	T.C.	Operating Temp	NPO (C0G)	-55~125°C at 25°C	X8G	-55~150°C at 25°C	X8R	-55~150°C at 25°C	X7R	-55~125°C at 25°C	X7S	-55~125°C at 25°C	X6S	-55~105°C at 25°C	X5R	-55~85°C at 25°C	Y5V	-25~85°C at 20°C	01005	0201	Cap≤0.01μF: 0.5V	Cap<0.1μF: 1V	Cap>0.01μF: 0.2V	0.1μF≤Cap<1μF: 0.2V		Cap≥1μF: 0.1V	0402	0603	Cap<1μF: 1V	Cap≤1μF: 1V	Cap=1μF: 0.5V	1μF<Cap≤4.7μF: 0.5V	1μF<Cap<10μF: 0.2V	Cap>4.7μF: 0.2V	Cap≥10μF: 0.1V		0805	1206/1210	Cap<10μF: 1V	Cap≤10μF: 1V	Cap=10μF: 0.5V	10μF<Cap≤100μF: 0.5V	Cap>10μF: 0.2V	Cap>100μF: 0.2V	<table border="1"> <thead> <tr> <th>T.C.</th> <th>Capacitance Change</th> </tr> </thead> <tbody> <tr> <td>NPO (C0G)</td> <td>Within ±30ppm/°C</td> </tr> <tr> <td>X8G</td> <td>Within ±30ppm/°C</td> </tr> <tr> <td>X8R</td> <td>Within ±15%</td> </tr> <tr> <td>X7R</td> <td>Within ±15%</td> </tr> <tr> <td>X7S</td> <td>Within ±22%</td> </tr> <tr> <td>X6S</td> <td>Within ±22%</td> </tr> <tr> <td>X5R</td> <td>Within ±15%</td> </tr> <tr> <td>Y5V</td> <td>Within +30%/-80%</td> </tr> </tbody> </table>	T.C.	Capacitance Change	NPO (C0G)	Within ±30ppm/°C	X8G	Within ±30ppm/°C	X8R	Within ±15%	X7R	Within ±15%	X7S	Within ±22%	X6S	Within ±22%	X5R	Within ±15%	Y5V	Within +30%/-80%
T.C.	Operating Temp																																																																
NPO (C0G)	-55~125°C at 25°C																																																																
X8G	-55~150°C at 25°C																																																																
X8R	-55~150°C at 25°C																																																																
X7R	-55~125°C at 25°C																																																																
X7S	-55~125°C at 25°C																																																																
X6S	-55~105°C at 25°C																																																																
X5R	-55~85°C at 25°C																																																																
Y5V	-25~85°C at 20°C																																																																
01005	0201																																																																
Cap≤0.01μF: 0.5V	Cap<0.1μF: 1V																																																																
Cap>0.01μF: 0.2V	0.1μF≤Cap<1μF: 0.2V																																																																
	Cap≥1μF: 0.1V																																																																
0402	0603																																																																
Cap<1μF: 1V	Cap≤1μF: 1V																																																																
Cap=1μF: 0.5V	1μF<Cap≤4.7μF: 0.5V																																																																
1μF<Cap<10μF: 0.2V	Cap>4.7μF: 0.2V																																																																
Cap≥10μF: 0.1V																																																																	
0805	1206/1210																																																																
Cap<10μF: 1V	Cap≤10μF: 1V																																																																
Cap=10μF: 0.5V	10μF<Cap≤100μF: 0.5V																																																																
Cap>10μF: 0.2V	Cap>100μF: 0.2V																																																																
T.C.	Capacitance Change																																																																
NPO (C0G)	Within ±30ppm/°C																																																																
X8G	Within ±30ppm/°C																																																																
X8R	Within ±15%																																																																
X7R	Within ±15%																																																																
X7S	Within ±22%																																																																
X6S	Within ±22%																																																																
X5R	Within ±15%																																																																
Y5V	Within +30%/-80%																																																																
7.	Adhesive Strength of Termination	<p>*Pressurizing force: 01005:1N, 0201:2N, 0402 & 0603:5N, >0603: 10N</p> <p>*Test time : 10 ±1 sec</p>	* No remarkable damage or removal of the terminations.																																																														
8.	Vibration Resistance	<p>*Vibration frequency: 10~55 Hz/min.</p> <p>*Total amplitude: 1.5mm</p> <p>*Test time: 6 hrs.(Two hrs each in three mutually perpendicular directions.)</p> <p>*Before initial measurement (Class II only): To apply de-aging at 150°C for 1hr then set for 24±2 hrs at room condition**.</p> <p>*Cap./DF(Q) Measurement to be made after de-aging at 150°C for 1hr then set for 24±2 hrs at room condition**.</p>	<p>* No remarkable damage.</p> <p>* Cap change and Q/D.F.: To meet initial spec.</p>																																																														
9.	Solderability	<p>* Solder temperature: 235±5°C</p> <p>* Dipping time: 2±0.5 sec.</p>	<p>95% MIN. coverage of all metalized area.**</p> <p>**SH series: 75% MIN. coverage of all metalized area.</p>																																																														
10.	Bending Test	<p>*The middle part of substrate shall be pressurized by means of the pressurizing rod at a rate of about 1 mm per second until the deflection becomes 1 mm / SH series: 5 mm and then the pressure shall be maintained for 5±1 sec.</p> <p>*Before initial measurement (Class II only): To apply de-aging at 150°C for 1hr then set for 24±2 hrs at room condition**.</p> <p>*Measurement to be made after keeping at room condition** for 24±2 hrs.</p>	<p>* No remarkable damage.</p> <p>* Cap change: NP0,X8G: within ±5% or 0.5pF whichever is larger X7R, X7S, X6S, X5R,X8R: within ±12.5% , Y5V: within ±30% (This capacitance change means the change of capacitance under specified flexure of substrate from the capacitance measured before the test.)</p>																																																														
11.	Resistance to Soldering Heat	<p>* Solder temperature: 260±5°C</p> <p>* Dipping time: 10±1 sec</p> <p>* Preheating: 120 to 150°C for 1 minute before immerse the capacitor in a eutectic solder.</p> <p>* Before initial measurement (Class II only): To apply de-aging at 150°C for 1hr then set for 24±2 hrs at room condition**.</p> <p>* Cap. / DF(Q) / I.R. Measurement to be made after de-aging at 150°C for 1hr then set for 24±2 hrs at room condition**.</p>	<p>* No remarkable damage.</p> <p>* Cap change: NP0,X8G: within ±2.5% or 0.25pF whichever is larger X7R, X7S, X6S, X5R,X8R: within ±7.5% Y5V: within ±20%</p> <p>* Q/D.F., I.R. and dielectric strength: To meet initial requirements.</p> <p>* 25% max. leaching on each edge.</p>																																																														
12.	Temperature Cycle	<p>* Conduct the five cycles according to the temperatures and time.</p> <table border="1"> <thead> <tr> <th>Step</th> <th>Temp. (°C)</th> <th>Time (min.)</th> </tr> </thead> <tbody> <tr> <td>1</td> <td>MIN. Operating Temp. +0/-3</td> <td>30±3</td> </tr> <tr> <td>2</td> <td>Room Temp.</td> <td>2~3</td> </tr> <tr> <td>3</td> <td>MAX. Operating Temp. +3/-0</td> <td>30±3</td> </tr> <tr> <td>4</td> <td>Room Temp.</td> <td>2~3</td> </tr> </tbody> </table> <p>* Before initial measurement (Class II only): To apply de-aging at 150°C for 1hr then set for 24±2 hrs at room condition**.</p> <p>* Cap. / DF(Q) / I.R. Measurement to be made after de-aging at 150°C for 1hr then set for 24±2 hrs at room condition**.</p>	Step	Temp. (°C)	Time (min.)	1	MIN. Operating Temp. +0/-3	30±3	2	Room Temp.	2~3	3	MAX. Operating Temp. +3/-0	30±3	4	Room Temp.	2~3	<p>* No remarkable damage.</p> <p>* Cap change: NP0,X8G: within ±2.5% or 0.25pF whichever is larger X7R, X7S, X6S, X5R,X8R: within ±7.5% Y5V: within ±20%</p> <p>* Q/D.F., I.R. and dielectric strength: To meet initial requirements.</p>																																															
Step	Temp. (°C)	Time (min.)																																																															
1	MIN. Operating Temp. +0/-3	30±3																																																															
2	Room Temp.	2~3																																																															
3	MAX. Operating Temp. +3/-0	30±3																																																															
4	Room Temp.	2~3																																																															

** "Room condition" Temperature: 15 to 35°C, Relative humidity: 25 to 75%, Atmospheric pressure: 86 to 106kPa.

This Reliability Test Conditions and Requirements only for General Purpose series, please refer to individual sheet for other products information.

No.	Item	Test Condition	Requirements																																																																																																						
13.	Humidity (Damp Heat) Steady State	<ul style="list-style-type: none"> * Test temp.: 40±2°C * Humidity: 90~95%RH * Test time: 500+24/-0hrs. * Before initial measurement (Class II only): To apply de-aging at 150°C for 1hr then set for 24±2 hrs at room condition**. * Cap. / DF(Q) / I.R. Measurement to be made after de-aging at 150°C for 1hr then set for 24±2 hrs at room condition**. 	<ul style="list-style-type: none"> * No remarkable damage. * Cap change: NP0, X8G: within ±5% or 0.5pF whichever is larger X7R, X7S, X6S, X5R, X8R: ≥10V**, within ±12.5%; 6.3V within ±25%; TT series, within ±25% **10V: 0603≥4.7μF; 0402≥1μF; 0201≥0.1μF, within ±25%; Y5V: ≥10V, within ±30%; 6.3V, within +30/-40% * Q/D.F. value: NP0, X8R: More than 30pF Q≥350, 10pF≤C≤30pF, Q≥275+2.5C, Less than 10pF Q≥200+10C X8R: ≤7.5% <p>X7R, X6S, X5R, X7S:</p> <table border="1"> <thead> <tr> <th>Rated vol.</th> <th>D.F. ≤</th> <th colspan="2">Exception of D.F. ≤</th> </tr> </thead> <tbody> <tr> <td rowspan="3">≥100V</td> <td rowspan="3">≤3%</td> <td>≤6%</td> <td>1206≥0.47μF</td> </tr> <tr> <td>≤7.5%</td> <td>0805>0.1μF, 0603≥0.068μF, 1206>1μF; 1210≥2.2μF; TT series</td> </tr> <tr> <td>≤20%</td> <td>0805>0.22μF; 1210≥3.3μF</td> </tr> <tr> <td rowspan="3">50V</td> <td rowspan="3">≤3%</td> <td>≤6%</td> <td>0201(50V); 0603≥0.047μF; 0805≥0.18μF; 1206≥0.47μF</td> </tr> <tr> <td>≤10%</td> <td>0201≥0.01μF; 1210≥4.7μF</td> </tr> <tr> <td>≤20%</td> <td>0402≥0.012μF; 0603>0.1μF; 0805≥1μF; 1206≥2.2μF; 1210≥10μF; TT series</td> </tr> <tr> <td>35V</td> <td>≤5%</td> <td>≤20%</td> <td>0603≥1μF; 0805≥2.2μF; 1206≥2.2μF; 1210≥10μF</td> </tr> <tr> <td rowspan="4">25V</td> <td rowspan="4">≤5%</td> <td>≤10%</td> <td>0201≥0.01μF; 0805≥1μF; 1210≥10μF</td> </tr> <tr> <td>≤14%</td> <td>0603≥0.33μF</td> </tr> <tr> <td>≤15%</td> <td>0201≥0.1μF; 0402≥0.10μF & (0402/X7R≥0.056μF); TT series 0603≥0.47μF; 0805≥2.2μF; 1206≥4.7μF; 1210≥22μF</td> </tr> <tr> <td>≤20%</td> <td>0402≥0.47μF</td> </tr> <tr> <td rowspan="2">16V</td> <td rowspan="2">≤5%</td> <td>≤10%</td> <td>0603≥0.15μF; 0805≥0.68μF; 1206≥2.2μF; 1210≥4.7μF</td> </tr> <tr> <td>≤15%</td> <td>0201≥0.01μF(0201/X7R≥0.022μF); 0402≥0.033μF; 0603≥0.68μF; 0805≥2.2μF; 1206≥4.7μF; 1210≥22μF; TT series</td> </tr> <tr> <td rowspan="2">10V</td> <td rowspan="2">≤7.5%</td> <td>≤15%</td> <td>0201≥0.012μF; 0402≥0.33μF(0402/X7R≥0.22μF); 0603≥0.33μF; 0805≥2.2μF; 1206≥2.2μF; 1210≥22μF</td> </tr> <tr> <td>≤20%</td> <td>0201≥0.1μF; 0402≥1μF; TT series; 01R5/X5R</td> </tr> <tr> <td>6.3V</td> <td>≤15%</td> <td>≤30%</td> <td>0201≥0.1μF; 0402≥1μF; 0603≥10μF; 0805≥4.7μF; 1206≥47μF; 1210≥100μF; TT series</td> </tr> <tr> <td>4V</td> <td>≤20%</td> <td>---</td> <td>---</td> </tr> </tbody> </table> <p>Y5V:</p> <table border="1"> <thead> <tr> <th>Rated vol.</th> <th>D.F. ≤</th> <th colspan="2">Exception of D.F. ≤</th> </tr> </thead> <tbody> <tr> <td rowspan="2">≥50V</td> <td rowspan="2">≤7.5%</td> <td>≤10%</td> <td>0603≥0.1μF; 0805≥0.47μF; 1206≥4.7μF; TT series</td> </tr> <tr> <td>≤20%</td> <td>1210≥6.8μF</td> </tr> <tr> <td>35V</td> <td>≤10%</td> <td>---</td> <td>---</td> </tr> <tr> <td rowspan="2">25V</td> <td rowspan="2">≤7.5%</td> <td>≤10%</td> <td>0402≥0.047μF; 0603≥0.1μF; 0805≥0.33μF; 1206≥1μF; 1210≥4.7μF</td> </tr> <tr> <td>≤15%</td> <td>0402≥0.068μF; 0603≥0.47μF; 1206≥4.7μF; 1210≥22μF; TT series</td> </tr> <tr> <td>16V (C<1.0μF)</td> <td>≤10%</td> <td>≤12.5%</td> <td>0402≥0.068μF; 0603≥0.68μF</td> </tr> <tr> <td rowspan="2">16V (C≥1.0μF)</td> <td rowspan="2">≤12.5%</td> <td>≤20%</td> <td>0402≥0.22μF</td> </tr> <tr> <td>≤30%</td> <td>0603≥2.2μF; 0805≥3.3μF; 1206≥10μF; 1210≥22μF; 1812≥47μF; TT series</td> </tr> <tr> <td>10V</td> <td>≤20%</td> <td>≤30%</td> <td>0402≥0.47μF</td> </tr> <tr> <td>6.3V</td> <td>≤30%</td> <td>---</td> <td>---</td> </tr> </tbody> </table> <p>* I.R.: ≥10V, 1GΩ or 50 Ω·F whichever is smaller.</p> <p>Class II (X7R, X6S, X5R, X7S, Y5V)</p> <table border="1"> <thead> <tr> <th>Rated voltage</th> <th>Insulation Resistance</th> </tr> </thead> <tbody> <tr> <td>100V: All X7R; 1210≥3.3μF</td> <td rowspan="7">1GΩ or RxC≥10 Ω·F whichever is smaller.</td> </tr> <tr> <td>50V: 0402>0.01μF; 0603≥1μF; 0805≥1μF; 1206≥4.7μF; 1210≥4.7μF</td> </tr> <tr> <td>35V: 0603≥1μF; 0805≥2.2μF; 1206≥2.2μF; 1210≥10μF</td> </tr> <tr> <td>25V: 0201≥0.1μF; 0402≥0.22μF; 0603≥2.2μF; 0805≥2.2μF; 1206≥10μF; 1210≥10μF</td> </tr> <tr> <td>16V: 0201≥0.1μF; 0402≥0.22μF; 0603≥1μF; 0805≥2.2μF; 1206≥10μF; 1210≥47μF</td> </tr> <tr> <td>10V: 0201≥47nF; 0402≥0.47μF; 0603≥0.47μF; 0805≥2.2μF; 1206≥4.7μF; 1210≥47μF</td> </tr> <tr> <td>6.3V; 4V; TT series; All X6S/X7S items; Size≥1812; 01R5/X5R</td> </tr> </tbody> </table>	Rated vol.	D.F. ≤	Exception of D.F. ≤		≥100V	≤3%	≤6%	1206≥0.47μF	≤7.5%	0805>0.1μF, 0603≥0.068μF, 1206>1μF; 1210≥2.2μF; TT series	≤20%	0805>0.22μF; 1210≥3.3μF	50V	≤3%	≤6%	0201(50V); 0603≥0.047μF; 0805≥0.18μF; 1206≥0.47μF	≤10%	0201≥0.01μF; 1210≥4.7μF	≤20%	0402≥0.012μF; 0603>0.1μF; 0805≥1μF; 1206≥2.2μF; 1210≥10μF; TT series	35V	≤5%	≤20%	0603≥1μF; 0805≥2.2μF; 1206≥2.2μF; 1210≥10μF	25V	≤5%	≤10%	0201≥0.01μF; 0805≥1μF; 1210≥10μF	≤14%	0603≥0.33μF	≤15%	0201≥0.1μF; 0402≥0.10μF & (0402/X7R≥0.056μF); TT series 0603≥0.47μF; 0805≥2.2μF; 1206≥4.7μF; 1210≥22μF	≤20%	0402≥0.47μF	16V	≤5%	≤10%	0603≥0.15μF; 0805≥0.68μF; 1206≥2.2μF; 1210≥4.7μF	≤15%	0201≥0.01μF(0201/X7R≥0.022μF); 0402≥0.033μF; 0603≥0.68μF; 0805≥2.2μF; 1206≥4.7μF; 1210≥22μF; TT series	10V	≤7.5%	≤15%	0201≥0.012μF; 0402≥0.33μF(0402/X7R≥0.22μF); 0603≥0.33μF; 0805≥2.2μF; 1206≥2.2μF; 1210≥22μF	≤20%	0201≥0.1μF; 0402≥1μF; TT series; 01R5/X5R	6.3V	≤15%	≤30%	0201≥0.1μF; 0402≥1μF; 0603≥10μF; 0805≥4.7μF; 1206≥47μF; 1210≥100μF; TT series	4V	≤20%	---	---	Rated vol.	D.F. ≤	Exception of D.F. ≤		≥50V	≤7.5%	≤10%	0603≥0.1μF; 0805≥0.47μF; 1206≥4.7μF; TT series	≤20%	1210≥6.8μF	35V	≤10%	---	---	25V	≤7.5%	≤10%	0402≥0.047μF; 0603≥0.1μF; 0805≥0.33μF; 1206≥1μF; 1210≥4.7μF	≤15%	0402≥0.068μF; 0603≥0.47μF; 1206≥4.7μF; 1210≥22μF; TT series	16V (C<1.0μF)	≤10%	≤12.5%	0402≥0.068μF; 0603≥0.68μF	16V (C≥1.0μF)	≤12.5%	≤20%	0402≥0.22μF	≤30%	0603≥2.2μF; 0805≥3.3μF; 1206≥10μF; 1210≥22μF; 1812≥47μF; TT series	10V	≤20%	≤30%	0402≥0.47μF	6.3V	≤30%	---	---	Rated voltage	Insulation Resistance	100V: All X7R; 1210≥3.3μF	1GΩ or RxC≥10 Ω·F whichever is smaller.	50V: 0402>0.01μF; 0603≥1μF; 0805≥1μF; 1206≥4.7μF; 1210≥4.7μF	35V: 0603≥1μF; 0805≥2.2μF; 1206≥2.2μF; 1210≥10μF	25V: 0201≥0.1μF; 0402≥0.22μF; 0603≥2.2μF; 0805≥2.2μF; 1206≥10μF; 1210≥10μF	16V: 0201≥0.1μF; 0402≥0.22μF; 0603≥1μF; 0805≥2.2μF; 1206≥10μF; 1210≥47μF	10V: 0201≥47nF; 0402≥0.47μF; 0603≥0.47μF; 0805≥2.2μF; 1206≥4.7μF; 1210≥47μF	6.3V; 4V; TT series; All X6S/X7S items; Size≥1812; 01R5/X5R
Rated vol.	D.F. ≤	Exception of D.F. ≤																																																																																																							
≥100V	≤3%	≤6%	1206≥0.47μF																																																																																																						
		≤7.5%	0805>0.1μF, 0603≥0.068μF, 1206>1μF; 1210≥2.2μF; TT series																																																																																																						
		≤20%	0805>0.22μF; 1210≥3.3μF																																																																																																						
50V	≤3%	≤6%	0201(50V); 0603≥0.047μF; 0805≥0.18μF; 1206≥0.47μF																																																																																																						
		≤10%	0201≥0.01μF; 1210≥4.7μF																																																																																																						
		≤20%	0402≥0.012μF; 0603>0.1μF; 0805≥1μF; 1206≥2.2μF; 1210≥10μF; TT series																																																																																																						
35V	≤5%	≤20%	0603≥1μF; 0805≥2.2μF; 1206≥2.2μF; 1210≥10μF																																																																																																						
25V	≤5%	≤10%	0201≥0.01μF; 0805≥1μF; 1210≥10μF																																																																																																						
		≤14%	0603≥0.33μF																																																																																																						
		≤15%	0201≥0.1μF; 0402≥0.10μF & (0402/X7R≥0.056μF); TT series 0603≥0.47μF; 0805≥2.2μF; 1206≥4.7μF; 1210≥22μF																																																																																																						
		≤20%	0402≥0.47μF																																																																																																						
16V	≤5%	≤10%	0603≥0.15μF; 0805≥0.68μF; 1206≥2.2μF; 1210≥4.7μF																																																																																																						
		≤15%	0201≥0.01μF(0201/X7R≥0.022μF); 0402≥0.033μF; 0603≥0.68μF; 0805≥2.2μF; 1206≥4.7μF; 1210≥22μF; TT series																																																																																																						
10V	≤7.5%	≤15%	0201≥0.012μF; 0402≥0.33μF(0402/X7R≥0.22μF); 0603≥0.33μF; 0805≥2.2μF; 1206≥2.2μF; 1210≥22μF																																																																																																						
		≤20%	0201≥0.1μF; 0402≥1μF; TT series; 01R5/X5R																																																																																																						
6.3V	≤15%	≤30%	0201≥0.1μF; 0402≥1μF; 0603≥10μF; 0805≥4.7μF; 1206≥47μF; 1210≥100μF; TT series																																																																																																						
4V	≤20%	---	---																																																																																																						
Rated vol.	D.F. ≤	Exception of D.F. ≤																																																																																																							
≥50V	≤7.5%	≤10%	0603≥0.1μF; 0805≥0.47μF; 1206≥4.7μF; TT series																																																																																																						
		≤20%	1210≥6.8μF																																																																																																						
35V	≤10%	---	---																																																																																																						
25V	≤7.5%	≤10%	0402≥0.047μF; 0603≥0.1μF; 0805≥0.33μF; 1206≥1μF; 1210≥4.7μF																																																																																																						
		≤15%	0402≥0.068μF; 0603≥0.47μF; 1206≥4.7μF; 1210≥22μF; TT series																																																																																																						
16V (C<1.0μF)	≤10%	≤12.5%	0402≥0.068μF; 0603≥0.68μF																																																																																																						
16V (C≥1.0μF)	≤12.5%	≤20%	0402≥0.22μF																																																																																																						
		≤30%	0603≥2.2μF; 0805≥3.3μF; 1206≥10μF; 1210≥22μF; 1812≥47μF; TT series																																																																																																						
10V	≤20%	≤30%	0402≥0.47μF																																																																																																						
6.3V	≤30%	---	---																																																																																																						
Rated voltage	Insulation Resistance																																																																																																								
100V: All X7R; 1210≥3.3μF	1GΩ or RxC≥10 Ω·F whichever is smaller.																																																																																																								
50V: 0402>0.01μF; 0603≥1μF; 0805≥1μF; 1206≥4.7μF; 1210≥4.7μF																																																																																																									
35V: 0603≥1μF; 0805≥2.2μF; 1206≥2.2μF; 1210≥10μF																																																																																																									
25V: 0201≥0.1μF; 0402≥0.22μF; 0603≥2.2μF; 0805≥2.2μF; 1206≥10μF; 1210≥10μF																																																																																																									
16V: 0201≥0.1μF; 0402≥0.22μF; 0603≥1μF; 0805≥2.2μF; 1206≥10μF; 1210≥47μF																																																																																																									
10V: 0201≥47nF; 0402≥0.47μF; 0603≥0.47μF; 0805≥2.2μF; 1206≥4.7μF; 1210≥47μF																																																																																																									
6.3V; 4V; TT series; All X6S/X7S items; Size≥1812; 01R5/X5R																																																																																																									

** "Room condition" Temperature: 15 to 35°C, Relative humidity: 25 to 75%, Atmospheric pressure: 86 to 106kPa.

This Reliability Test Conditions and Requirements only for General Purpose series, please refer to individual sheet for other products information.

No.	Item	Test Condition	Requirements																																																																																																				
14	Humidity (Damp Heat) Load	<p>*Test temp. : 40±2°C</p> <p>*Humidity : 90~95%RH</p> <p>*Test time : 500+24/-0 hrs.</p> <p>*To apply voltage : rated voltage (MAX. 500V)</p> <p>*Before initial measurement (Class II only): To apply de-aging at 150°C for 1hr then set for 24±2 hrs at room condition**.</p> <p>*Cap. / DF(Q) / I.R. Measurement to be made after de-aging at 150°C for 1hr then set for 24±2 hrs at room condition**.</p>	<p>* No remarkable damage.</p> <p>Cap change: NP0, X8G: ±7.5% or 0.75pF whichever is larger.</p> <p>X7R, X7S, X6S, X5R, X8R: ≥10V**within ±12.5%; 6.3V within ±25%; TT series, within ±25%</p> <p>**10V: 0603≥4.7μF; 0402≥1μF; 0201≥0.1μF, within ±25%;</p> <p>Y5V: ≥10V, within ±30%; 6.3V, within +30/-40%</p> <p>Q/D.F. value: NP0, X8G: C≥30pF, Q≥200; C<30pF, Q≥100+10/3C</p> <p>X8R: ≤7.5%</p> <p>X7R, X6S, X5R, X7S:</p> <table border="1"> <thead> <tr> <th>Rated vol.</th> <th>D.F. ≤</th> <th colspan="2">Exception of D.F. ≤</th> </tr> </thead> <tbody> <tr> <td rowspan="3">≥100V</td> <td rowspan="3">≤3%</td> <td>≤6%</td> <td>1206≥0.47μF</td> </tr> <tr> <td>≤7.5%</td> <td>0805>0.1μF, 0603≥0.068μF, 1206>1μF; 1210≥2.2μF; TT series</td> </tr> <tr> <td>≤20%</td> <td>0805>0.22μF; 1210≥3.3μF</td> </tr> <tr> <td rowspan="3">50V</td> <td rowspan="3">≤3%</td> <td>≤6%</td> <td>0201(50V); 0603≥0.047μF; 0805≥0.18μF; 1206≥0.47μF</td> </tr> <tr> <td>≤10%</td> <td>0201≥0.01μF; 1210≥4.7μF</td> </tr> <tr> <td>≤20%</td> <td>0402≥0.012μF; 0603>0.1μF; 0805≥1μF; 1206≥2.2μF; 1210≥10μF; TT series</td> </tr> <tr> <td>35V</td> <td>≤5%</td> <td>≤20%</td> <td>0603≥1μF; 0805≥2.2μF; 1206≥2.2μF; 1210≥10μF</td> </tr> <tr> <td rowspan="4">25V</td> <td rowspan="4">≤5%</td> <td>≤10%</td> <td>0201≥0.01μF; 0805≥1μF; 1210≥10μF</td> </tr> <tr> <td>≤14%</td> <td>0603≥0.33μF</td> </tr> <tr> <td>≤15%</td> <td>0201≥0.1μF; 0402≥0.10μF&(0402/X7R≥0.056μF); TT series</td> </tr> <tr> <td>≤20%</td> <td>0603≥0.47μF; 0805≥2.2μF; 1206≥4.7μF; 1210≥22μF</td> </tr> <tr> <td rowspan="2">16V</td> <td rowspan="2">≤5%</td> <td>≤10%</td> <td>0603≥0.15μF; 0805≥0.68μF; 1206≥2.2μF; 1210≥4.7μF</td> </tr> <tr> <td>≤15%</td> <td>0201≥0.01μF(0201/X7R≥0.022μF); 0402≥0.033μF; 0603≥0.68μF; 0805≥2.2μF; 1206≥4.7μF; 1210≥22μF; TT series</td> </tr> <tr> <td rowspan="2">10V</td> <td rowspan="2">≤7.5%</td> <td>≤15%</td> <td>0201≥0.012μF; 0402≥0.33μF(0402/X7R≥0.22μF); 0603≥0.33μF; 0805≥2.2μF; 1206≥2.2μF; 1210≥22μF</td> </tr> <tr> <td>≤20%</td> <td>0201≥0.1μF; 0402≥1μF; TT series; 01R5/X5R</td> </tr> <tr> <td>6.3V</td> <td>≤15%</td> <td>≤30%</td> <td>0201≥0.1μF; 0402≥1μF; 0603≥10μF; 0805≥4.7μF; 1206≥47μF; 1210≥100μF; TT series</td> </tr> <tr> <td>4V</td> <td>≤20%</td> <td>---</td> <td>---</td> </tr> </tbody> </table> <p>Y5V:</p> <table border="1"> <thead> <tr> <th>Rated vol.</th> <th>D.F. ≤</th> <th colspan="2">Exception of D.F. ≤</th> </tr> </thead> <tbody> <tr> <td rowspan="2">≥50V</td> <td rowspan="2">≤7.5%</td> <td>≤10%</td> <td>0603≥0.1μF; 0805≥0.47μF; 1206≥4.7μF; TT series</td> </tr> <tr> <td>≤20%</td> <td>1210≥6.8μF</td> </tr> <tr> <td>35V</td> <td>≤10%</td> <td>---</td> <td>---</td> </tr> <tr> <td rowspan="2">25V</td> <td rowspan="2">≤7.5%</td> <td>≤10%</td> <td>0402≥0.047μF; 0603≥0.1μF; 0805≥0.33μF; 1206≥1μF; 1210≥4.7μF</td> </tr> <tr> <td>≤15%</td> <td>0402≥0.068μF; 0603≥0.47μF; 1206≥4.7μF; 1210≥22μF; TT series</td> </tr> <tr> <td rowspan="2">16V (C<1.0μF)</td> <td rowspan="2">≤10%</td> <td>≤12.5%</td> <td>0402≥0.068μF; 0603≥0.68μF</td> </tr> <tr> <td>≤20%</td> <td>0402≥0.22μF</td> </tr> <tr> <td rowspan="2">16V (C≥1.0μF)</td> <td rowspan="2">≤12.5%</td> <td>≤20%</td> <td>0603≥2.2μF; 0805≥3.3μF; 1206≥10μF; 1210≥22μF; 1812≥47μF; TT series</td> </tr> <tr> <td>≤30%</td> <td>0402≥0.47μF</td> </tr> <tr> <td>6.3V</td> <td>≤30%</td> <td>---</td> <td>---</td> </tr> </tbody> </table> <p>*I.R.: ≥10V, 500MΩ or 25 Ω-F whichever is smaller.</p> <p>Class II (X7R, X7S, X6S, X5R, Y5V)</p> <table border="1"> <thead> <tr> <th>Rated voltage</th> <th>Insulation Resistance</th> </tr> </thead> <tbody> <tr> <td>100V: All X7R; 1210≥3.3μF</td> <td rowspan="7">500MΩ or RxC≥5 Ω-F whichever is smaller.</td> </tr> <tr> <td>50V: 0402>0.01μF; 0603≥1μF; 0805≥1μF; 1206≥4.7μF; 1210≥4.7μF</td> </tr> <tr> <td>35V: 0603≥1μF; 0805≥2.2μF; 1206≥2.2μF; 1210≥10μF</td> </tr> <tr> <td>25V: 0201≥0.1μF; 0402≥0.22μF; 0603≥2.2μF; 0805≥2.2μF; 1206≥10μF; 1210≥10μF</td> </tr> <tr> <td>16V: 0201≥0.1μF; 0402≥0.22μF; 0603≥1μF; 0805≥2.2μF; 1206≥10μF; 1210≥47μF</td> </tr> <tr> <td>10V: 0201≥47nF; 0402≥0.47μF; 0603≥0.47μF; 0805≥2.2μF; 1206≥4.7μF; 1210≥47μF</td> </tr> <tr> <td>6.3V; 4V; TT series; All X6S/X7S items; Size≥1812; 01R5/X5R</td> </tr> </tbody> </table>	Rated vol.	D.F. ≤	Exception of D.F. ≤		≥100V	≤3%	≤6%	1206≥0.47μF	≤7.5%	0805>0.1μF, 0603≥0.068μF, 1206>1μF; 1210≥2.2μF; TT series	≤20%	0805>0.22μF; 1210≥3.3μF	50V	≤3%	≤6%	0201(50V); 0603≥0.047μF; 0805≥0.18μF; 1206≥0.47μF	≤10%	0201≥0.01μF; 1210≥4.7μF	≤20%	0402≥0.012μF; 0603>0.1μF; 0805≥1μF; 1206≥2.2μF; 1210≥10μF; TT series	35V	≤5%	≤20%	0603≥1μF; 0805≥2.2μF; 1206≥2.2μF; 1210≥10μF	25V	≤5%	≤10%	0201≥0.01μF; 0805≥1μF; 1210≥10μF	≤14%	0603≥0.33μF	≤15%	0201≥0.1μF; 0402≥0.10μF&(0402/X7R≥0.056μF); TT series	≤20%	0603≥0.47μF; 0805≥2.2μF; 1206≥4.7μF; 1210≥22μF	16V	≤5%	≤10%	0603≥0.15μF; 0805≥0.68μF; 1206≥2.2μF; 1210≥4.7μF	≤15%	0201≥0.01μF(0201/X7R≥0.022μF); 0402≥0.033μF; 0603≥0.68μF; 0805≥2.2μF; 1206≥4.7μF; 1210≥22μF; TT series	10V	≤7.5%	≤15%	0201≥0.012μF; 0402≥0.33μF(0402/X7R≥0.22μF); 0603≥0.33μF; 0805≥2.2μF; 1206≥2.2μF; 1210≥22μF	≤20%	0201≥0.1μF; 0402≥1μF; TT series; 01R5/X5R	6.3V	≤15%	≤30%	0201≥0.1μF; 0402≥1μF; 0603≥10μF; 0805≥4.7μF; 1206≥47μF; 1210≥100μF; TT series	4V	≤20%	---	---	Rated vol.	D.F. ≤	Exception of D.F. ≤		≥50V	≤7.5%	≤10%	0603≥0.1μF; 0805≥0.47μF; 1206≥4.7μF; TT series	≤20%	1210≥6.8μF	35V	≤10%	---	---	25V	≤7.5%	≤10%	0402≥0.047μF; 0603≥0.1μF; 0805≥0.33μF; 1206≥1μF; 1210≥4.7μF	≤15%	0402≥0.068μF; 0603≥0.47μF; 1206≥4.7μF; 1210≥22μF; TT series	16V (C<1.0μF)	≤10%	≤12.5%	0402≥0.068μF; 0603≥0.68μF	≤20%	0402≥0.22μF	16V (C≥1.0μF)	≤12.5%	≤20%	0603≥2.2μF; 0805≥3.3μF; 1206≥10μF; 1210≥22μF; 1812≥47μF; TT series	≤30%	0402≥0.47μF	6.3V	≤30%	---	---	Rated voltage	Insulation Resistance	100V: All X7R; 1210≥3.3μF	500MΩ or RxC≥5 Ω-F whichever is smaller.	50V: 0402>0.01μF; 0603≥1μF; 0805≥1μF; 1206≥4.7μF; 1210≥4.7μF	35V: 0603≥1μF; 0805≥2.2μF; 1206≥2.2μF; 1210≥10μF	25V: 0201≥0.1μF; 0402≥0.22μF; 0603≥2.2μF; 0805≥2.2μF; 1206≥10μF; 1210≥10μF	16V: 0201≥0.1μF; 0402≥0.22μF; 0603≥1μF; 0805≥2.2μF; 1206≥10μF; 1210≥47μF	10V: 0201≥47nF; 0402≥0.47μF; 0603≥0.47μF; 0805≥2.2μF; 1206≥4.7μF; 1210≥47μF	6.3V; 4V; TT series; All X6S/X7S items; Size≥1812; 01R5/X5R
Rated vol.	D.F. ≤	Exception of D.F. ≤																																																																																																					
≥100V	≤3%	≤6%	1206≥0.47μF																																																																																																				
		≤7.5%	0805>0.1μF, 0603≥0.068μF, 1206>1μF; 1210≥2.2μF; TT series																																																																																																				
		≤20%	0805>0.22μF; 1210≥3.3μF																																																																																																				
50V	≤3%	≤6%	0201(50V); 0603≥0.047μF; 0805≥0.18μF; 1206≥0.47μF																																																																																																				
		≤10%	0201≥0.01μF; 1210≥4.7μF																																																																																																				
		≤20%	0402≥0.012μF; 0603>0.1μF; 0805≥1μF; 1206≥2.2μF; 1210≥10μF; TT series																																																																																																				
35V	≤5%	≤20%	0603≥1μF; 0805≥2.2μF; 1206≥2.2μF; 1210≥10μF																																																																																																				
25V	≤5%	≤10%	0201≥0.01μF; 0805≥1μF; 1210≥10μF																																																																																																				
		≤14%	0603≥0.33μF																																																																																																				
		≤15%	0201≥0.1μF; 0402≥0.10μF&(0402/X7R≥0.056μF); TT series																																																																																																				
		≤20%	0603≥0.47μF; 0805≥2.2μF; 1206≥4.7μF; 1210≥22μF																																																																																																				
16V	≤5%	≤10%	0603≥0.15μF; 0805≥0.68μF; 1206≥2.2μF; 1210≥4.7μF																																																																																																				
		≤15%	0201≥0.01μF(0201/X7R≥0.022μF); 0402≥0.033μF; 0603≥0.68μF; 0805≥2.2μF; 1206≥4.7μF; 1210≥22μF; TT series																																																																																																				
10V	≤7.5%	≤15%	0201≥0.012μF; 0402≥0.33μF(0402/X7R≥0.22μF); 0603≥0.33μF; 0805≥2.2μF; 1206≥2.2μF; 1210≥22μF																																																																																																				
		≤20%	0201≥0.1μF; 0402≥1μF; TT series; 01R5/X5R																																																																																																				
6.3V	≤15%	≤30%	0201≥0.1μF; 0402≥1μF; 0603≥10μF; 0805≥4.7μF; 1206≥47μF; 1210≥100μF; TT series																																																																																																				
4V	≤20%	---	---																																																																																																				
Rated vol.	D.F. ≤	Exception of D.F. ≤																																																																																																					
≥50V	≤7.5%	≤10%	0603≥0.1μF; 0805≥0.47μF; 1206≥4.7μF; TT series																																																																																																				
		≤20%	1210≥6.8μF																																																																																																				
35V	≤10%	---	---																																																																																																				
25V	≤7.5%	≤10%	0402≥0.047μF; 0603≥0.1μF; 0805≥0.33μF; 1206≥1μF; 1210≥4.7μF																																																																																																				
		≤15%	0402≥0.068μF; 0603≥0.47μF; 1206≥4.7μF; 1210≥22μF; TT series																																																																																																				
16V (C<1.0μF)	≤10%	≤12.5%	0402≥0.068μF; 0603≥0.68μF																																																																																																				
		≤20%	0402≥0.22μF																																																																																																				
16V (C≥1.0μF)	≤12.5%	≤20%	0603≥2.2μF; 0805≥3.3μF; 1206≥10μF; 1210≥22μF; 1812≥47μF; TT series																																																																																																				
		≤30%	0402≥0.47μF																																																																																																				
6.3V	≤30%	---	---																																																																																																				
Rated voltage	Insulation Resistance																																																																																																						
100V: All X7R; 1210≥3.3μF	500MΩ or RxC≥5 Ω-F whichever is smaller.																																																																																																						
50V: 0402>0.01μF; 0603≥1μF; 0805≥1μF; 1206≥4.7μF; 1210≥4.7μF																																																																																																							
35V: 0603≥1μF; 0805≥2.2μF; 1206≥2.2μF; 1210≥10μF																																																																																																							
25V: 0201≥0.1μF; 0402≥0.22μF; 0603≥2.2μF; 0805≥2.2μF; 1206≥10μF; 1210≥10μF																																																																																																							
16V: 0201≥0.1μF; 0402≥0.22μF; 0603≥1μF; 0805≥2.2μF; 1206≥10μF; 1210≥47μF																																																																																																							
10V: 0201≥47nF; 0402≥0.47μF; 0603≥0.47μF; 0805≥2.2μF; 1206≥4.7μF; 1210≥47μF																																																																																																							
6.3V; 4V; TT series; All X6S/X7S items; Size≥1812; 01R5/X5R																																																																																																							

** "Room condition" Temperature: 15 to 35°C, Relative humidity: 25 to 75%, Atmospheric pressure: 86 to 106kPa.

This Reliability Test Conditions and Requirements only for General Purpose series, please refer to individual sheet for other products information.

No.	Item	Test Condition	Requirements																																																																																																																																																																																																																																									
15.	High Temperature Load (Endurance)	<p>*Test temp. : X8G, X8R: 150±3°C NP0, X7R/ X7S: 125±3°C X6S: 105±3°C X5R, Y5V: 85±3°C</p> <p>*Test time: 1000+24/-0 hrs.</p> <p>*To apply voltage: (1) 100% of rated voltage for below range.</p> <table border="1"> <thead> <tr> <th>Size</th> <th>Dielectric</th> <th>Rated voltage</th> <th>Capacitance</th> </tr> </thead> <tbody> <tr> <td rowspan="2">0201</td> <td rowspan="2">X5R/X7R/X6S</td> <td>≤10V</td> <td>C≥0.1μF</td> </tr> <tr> <td>≥16V</td> <td>C>0.1μF</td> </tr> <tr> <td rowspan="4">0402</td> <td rowspan="2">X5R</td> <td>≤16V</td> <td>C>1.0μF</td> </tr> <tr> <td>25V, 50V</td> <td>C≥1.0μF</td> </tr> <tr> <td rowspan="2">X6S</td> <td>6.3V</td> <td>C>1.0μF</td> </tr> <tr> <td>10V~50V</td> <td>C≥1.0μF</td> </tr> <tr> <td>X7R/X7S/Y5V</td> <td>6.3V, 10V</td> <td>C≥1.0μF</td> </tr> <tr> <td rowspan="3">0603</td> <td rowspan="3">X5R/X7R/ X6S/X7S</td> <td>4V</td> <td>C≥22μF</td> </tr> <tr> <td>6.3V, 10V</td> <td>C≥4.7μF</td> </tr> <tr> <td>25V, 35V</td> <td>C≥1.0μF</td> </tr> <tr> <td rowspan="3">0805</td> <td rowspan="3">X5R/X7R/ X6S/X7S</td> <td>4V</td> <td>C≥47μF</td> </tr> <tr> <td>6.3V</td> <td>C≥22μF</td> </tr> <tr> <td>10V~50V</td> <td>C≥10μF</td> </tr> <tr> <td>1206</td> <td>X5R/X7R/X6S</td> <td>≤6.3V</td> <td>C≥47μF</td> </tr> <tr> <td rowspan="2">1210</td> <td>X5R/X7R/X6S</td> <td>16V</td> <td>C≥47μF</td> </tr> <tr> <td>X7R</td> <td>100V</td> <td>C≥3.3μF</td> </tr> <tr> <td>TT15</td> <td>X5R</td> <td>6.3V</td> <td>C > 1.0μF</td> </tr> <tr> <td>TT18</td> <td>Y5V</td> <td>6.3V, 10V</td> <td>C≥2.2μF</td> </tr> <tr> <td>TT21</td> <td>Y5V</td> <td>6.3V</td> <td>C≥10μF</td> </tr> <tr> <td rowspan="2">TT31</td> <td rowspan="2">X5R/X7R/X6S</td> <td>≤10V</td> <td>C≥10μF</td> </tr> <tr> <td>Y5V</td> <td>6.3V</td> <td>C≥22μF</td> </tr> </tbody> </table> <p>**1WV items must follow low de-rating conditions</p> <p>(2) 150% of rated voltage for below range.</p> <table border="1"> <thead> <tr> <th>Size</th> <th>Dielectric</th> <th>Rated voltage</th> <th>Capacitance</th> </tr> </thead> <tbody> <tr> <td rowspan="2">0201</td> <td>X5R/X6S</td> <td>16V/25V</td> <td>C=0.1μF</td> </tr> <tr> <td>X7R</td> <td>16V</td> <td>C≥0.022μF</td> </tr> <tr> <td rowspan="2">0402</td> <td rowspan="2">X5R/X7R/X6S</td> <td>50V</td> <td>C≥0.1μF</td> </tr> <tr> <td>10~25V</td> <td>C≥0.22μF</td> </tr> <tr> <td rowspan="4">0603</td> <td rowspan="2">Y5V</td> <td>16V</td> <td>C≥0.47μF</td> </tr> <tr> <td>50V~100V</td> <td>C>0.22μF</td> </tr> <tr> <td rowspan="2">X7S</td> <td>50V</td> <td>C>0.1μF</td> </tr> <tr> <td>X5R</td> <td>50V</td> <td>C≥1.0μF</td> </tr> <tr> <td rowspan="2">X5R/X7R/ X6S/X7S</td> <td>10V, 16V</td> <td>C≥1.0μF</td> </tr> <tr> <td>Y5V</td> <td>16V</td> <td>C≥2.2μF</td> </tr> <tr> <td rowspan="4">0805</td> <td rowspan="3">X5R/X7R/ X6S/X7S</td> <td>100V</td> <td>C≥0.47μF</td> </tr> <tr> <td>50V</td> <td>C≥1.0μF</td> </tr> <tr> <td>35V</td> <td>C≥2.2μF</td> </tr> <tr> <td>Y5V</td> <td>16V</td> <td>C≥4.7μF</td> </tr> <tr> <td rowspan="2">1206</td> <td rowspan="2">X5R/X7R/ X6S/X7S</td> <td>100V</td> <td>C>1.0μF</td> </tr> <tr> <td>50V</td> <td>C=4.7μF</td> </tr> <tr> <td>1210</td> <td>X5R/X7R/ X6S/X7S</td> <td>50V~100V</td> <td>C≥2.2μF</td> </tr> <tr> <td>1825 2220 2225</td> <td>X7R</td> <td>100V~250V</td> <td>C≥1.0μF</td> </tr> </tbody> </table> <p>(3) ≤6.3V or C≥10μF or TT series: 150% of rated voltage. (4) 10V~250V: 200% of rated voltage. (5) 400V~450V: 120% of rated voltage. (6) 500V: 150% of rated voltage. (7) 630~3000V: 120% of rated voltage. (8) Ur=4000V: 110% of rated voltage.</p> <p>*Before initial measurement (Class II only): To apply de-aging at 150°C for 1hr then set for 24±2 hrs at room condition**.</p> <p>*Cap. / DF(Q) / I.R. Measurement to be made after de-aging at 150°C for 1hr then set for 24±2 hrs at room condition**.</p>	Size	Dielectric	Rated voltage	Capacitance	0201	X5R/X7R/X6S	≤10V	C≥0.1μF	≥16V	C>0.1μF	0402	X5R	≤16V	C>1.0μF	25V, 50V	C≥1.0μF	X6S	6.3V	C>1.0μF	10V~50V	C≥1.0μF	X7R/X7S/Y5V	6.3V, 10V	C≥1.0μF	0603	X5R/X7R/ X6S/X7S	4V	C≥22μF	6.3V, 10V	C≥4.7μF	25V, 35V	C≥1.0μF	0805	X5R/X7R/ X6S/X7S	4V	C≥47μF	6.3V	C≥22μF	10V~50V	C≥10μF	1206	X5R/X7R/X6S	≤6.3V	C≥47μF	1210	X5R/X7R/X6S	16V	C≥47μF	X7R	100V	C≥3.3μF	TT15	X5R	6.3V	C > 1.0μF	TT18	Y5V	6.3V, 10V	C≥2.2μF	TT21	Y5V	6.3V	C≥10μF	TT31	X5R/X7R/X6S	≤10V	C≥10μF	Y5V	6.3V	C≥22μF	Size	Dielectric	Rated voltage	Capacitance	0201	X5R/X6S	16V/25V	C=0.1μF	X7R	16V	C≥0.022μF	0402	X5R/X7R/X6S	50V	C≥0.1μF	10~25V	C≥0.22μF	0603	Y5V	16V	C≥0.47μF	50V~100V	C>0.22μF	X7S	50V	C>0.1μF	X5R	50V	C≥1.0μF	X5R/X7R/ X6S/X7S	10V, 16V	C≥1.0μF	Y5V	16V	C≥2.2μF	0805	X5R/X7R/ X6S/X7S	100V	C≥0.47μF	50V	C≥1.0μF	35V	C≥2.2μF	Y5V	16V	C≥4.7μF	1206	X5R/X7R/ X6S/X7S	100V	C>1.0μF	50V	C=4.7μF	1210	X5R/X7R/ X6S/X7S	50V~100V	C≥2.2μF	1825 2220 2225	X7R	100V~250V	C≥1.0μF	<p>* No remarkable damage. Cap change: NP0, X8G: ±3.0% or ±0.3pF whichever is larger X7R, X7S, X6S, X5R, X8R: ≥10V**within ±12.5%; 6.3V within ±25%; TT series, within ±25% **10V: 0603≥4.7μF; 0402≥1μF; 0201≥0.1μF, within ±25%; Y5V: ≥10V, within ±30%; 6.3V, within +30/-40% Q/D.F. value: NP0, X8G: More than 30pF, Q≥350; 10pF≤C<30pF, Q≥275+2.5C; Less than 10pF, Q≥200+10C</p> <p>X8R: ≤7.5% X7R, X6S, X5R, X7S:</p> <table border="1"> <thead> <tr> <th>Rated vol.</th> <th>D.F. ≤</th> <th colspan="2">Exception of D.F. ≤</th> </tr> </thead> <tbody> <tr> <td rowspan="3">≥100V</td> <td rowspan="3">≤3%</td> <td>≤6%</td> <td>1206≥0.47μF</td> </tr> <tr> <td>≤7.5%</td> <td>0805>0.1μF, 0603≥0.068μF, 1206>1μF; 1210≥2.2μF; TT series</td> </tr> <tr> <td>≤20%</td> <td>0805>0.22μF; 1210≥3.3μF</td> </tr> <tr> <td rowspan="3">50V</td> <td rowspan="3">≤3%</td> <td>≤6%</td> <td>0201(50V); 0603≥0.047μF; 0805≥0.18μF; 1206≥0.47μF</td> </tr> <tr> <td>≤10%</td> <td>0201≥0.01μF; 1210≥4.7μF</td> </tr> <tr> <td>≤20%</td> <td>0402≥0.012μF; 0603>0.1μF; 0805≥1μF; 1206≥2.2μF; 1210≥10μF; TT series</td> </tr> <tr> <td>35V</td> <td>≤5%</td> <td>≤20%</td> <td>0603≥1μF; 0805≥2.2μF; 1206≥2.2μF; 1210≥10μF</td> </tr> <tr> <td rowspan="4">25V</td> <td rowspan="4">≤5%</td> <td>≤10%</td> <td>0201≥0.01μF; 0805≥1μF; 1210≥10μF</td> </tr> <tr> <td>≤14%</td> <td>0603≥0.33μF</td> </tr> <tr> <td>≤15%</td> <td>0201≥0.1μF; 0402≥0.10μF&(0402/X7R≥0.056μF); TT series; 0603≥0.47μF; 0805≥2.2μF; 1206≥4.7μF; 1210≥22μF</td> </tr> <tr> <td>≤20%</td> <td>0402≥0.47μF</td> </tr> <tr> <td rowspan="2">16V</td> <td rowspan="2">≤5%</td> <td>≤10%</td> <td>0603≥0.15μF; 0805≥0.68μF; 1206≥2.2μF; 1210≥4.7μF</td> </tr> <tr> <td>≤15%</td> <td>0201≥0.01μF(0201/X7R≥0.022μF); 0402≥0.033μF; 0603≥0.68μF; 0805≥2.2μF; 1206≥4.7μF; 1210≥22μF; TT series</td> </tr> <tr> <td rowspan="2">10V</td> <td rowspan="2">≤7.5%</td> <td>≤15%</td> <td>0201≥0.012μF; 0402≥0.33μF(0402/X7R≥0.22μF); 0603≥0.33μF; 0805≥2.2μF; 1206≥2.2μF; 1210≥22μF</td> </tr> <tr> <td>≤20%</td> <td>0201≥0.1μF; 0402≥1μF; TT series; 01R5/X5R</td> </tr> <tr> <td>6.3V</td> <td>≤15%</td> <td>≤30%</td> <td>0201≥0.1μF; 0402≥1μF; 0603≥10μF; 0805≥4.7μF; 1206≥47μF; 1210≥100μF; TT series</td> </tr> <tr> <td>4V</td> <td>≤20%</td> <td>---</td> <td>---</td> </tr> </tbody> </table> <p>Y5V:</p> <table border="1"> <thead> <tr> <th>Rated vol.</th> <th>D.F. ≤</th> <th colspan="2">Exception of D.F. ≤</th> </tr> </thead> <tbody> <tr> <td rowspan="2">≥50V</td> <td rowspan="2">≤7.5%</td> <td>≤10%</td> <td>0603≥0.1μF; 0805≥0.47μF; 1206≥4.7μF; TT series</td> </tr> <tr> <td>≤20%</td> <td>1210≥6.8μF</td> </tr> <tr> <td>35V</td> <td>≤10%</td> <td>---</td> <td>---</td> </tr> <tr> <td rowspan="2">25V</td> <td rowspan="2">≤7.5%</td> <td>≤10%</td> <td>0402≥0.047μF; 0603≥0.1μF; 0805≥0.33μF; 1206≥1μF; 1210≥4.7μF</td> </tr> <tr> <td>≤15%</td> <td>0402≥0.068μF; 0603≥0.47μF; 1206≥4.7μF; 1210≥22μF; TT series</td> </tr> <tr> <td>16V (C<1.0μF)</td> <td>≤10%</td> <td>≤12.5%</td> <td>0402≥0.068μF; 0603≥0.68μF</td> </tr> <tr> <td rowspan="2">16V (C≥1.0μF)</td> <td rowspan="2">≤12.5%</td> <td>≤20%</td> <td>0603≥2.2μF; 0805≥3.3μF; 1206≥10μF; 1210≥22μF; 1812≥47μF; TT series</td> </tr> <tr> <td>≤30%</td> <td>0402≥0.47μF</td> </tr> <tr> <td>10V</td> <td>≤20%</td> <td>≤30%</td> <td>0402≥0.47μF</td> </tr> <tr> <td>6.3V</td> <td>≤30%</td> <td>---</td> <td>---</td> </tr> </tbody> </table> <p>*I.R.: ≥10V, 1GΩ or 50 Ω-F whichever is smaller. Class II (X7R, X7S, X6S, X5R, Y5V)</p> <table border="1"> <thead> <tr> <th>Rated voltage</th> <th>Insulation Resistance</th> </tr> </thead> <tbody> <tr> <td>100V: All X7R; 1210≥3.3μF</td> <td rowspan="8">1GΩ or RxC≥10 Ω-F whichever is smaller.</td> </tr> <tr> <td>50V: 0402>0.01μF; 0603≥1μF; 0805≥1μF; 1206≥4.7μF; 1210≥4.7μF</td> </tr> <tr> <td>35V: 0603≥1μF; 0805≥2.2μF; 1206≥2.2μF; 1210≥10μF</td> </tr> <tr> <td>25V: 0201≥0.1μF; 0402≥0.22μF; 0603≥2.2μF; 0805≥2.2μF; 1206≥10μF; 1210≥10μF</td> </tr> <tr> <td>16V: 0201≥0.1μF; 0402≥0.22μF; 0603≥1μF; 0805≥2.2μF; 1206≥10μF; 1210≥47μF</td> </tr> <tr> <td>10V: 0201≥47nF; 0402≥0.47μF; 0603≥0.47μF; 0805≥2.2μF; 1206≥4.7μF; 1210≥47μF</td> </tr> <tr> <td>6.3V; 4V; TT series; All X6S/X7S items; Size≥1812; 01R5/X5R</td> </tr> <tr> <td>---</td> </tr> </tbody> </table>	Rated vol.	D.F. ≤	Exception of D.F. ≤		≥100V	≤3%	≤6%	1206≥0.47μF	≤7.5%	0805>0.1μF, 0603≥0.068μF, 1206>1μF; 1210≥2.2μF; TT series	≤20%	0805>0.22μF; 1210≥3.3μF	50V	≤3%	≤6%	0201(50V); 0603≥0.047μF; 0805≥0.18μF; 1206≥0.47μF	≤10%	0201≥0.01μF; 1210≥4.7μF	≤20%	0402≥0.012μF; 0603>0.1μF; 0805≥1μF; 1206≥2.2μF; 1210≥10μF; TT series	35V	≤5%	≤20%	0603≥1μF; 0805≥2.2μF; 1206≥2.2μF; 1210≥10μF	25V	≤5%	≤10%	0201≥0.01μF; 0805≥1μF; 1210≥10μF	≤14%	0603≥0.33μF	≤15%	0201≥0.1μF; 0402≥0.10μF&(0402/X7R≥0.056μF); TT series; 0603≥0.47μF; 0805≥2.2μF; 1206≥4.7μF; 1210≥22μF	≤20%	0402≥0.47μF	16V	≤5%	≤10%	0603≥0.15μF; 0805≥0.68μF; 1206≥2.2μF; 1210≥4.7μF	≤15%	0201≥0.01μF(0201/X7R≥0.022μF); 0402≥0.033μF; 0603≥0.68μF; 0805≥2.2μF; 1206≥4.7μF; 1210≥22μF; TT series	10V	≤7.5%	≤15%	0201≥0.012μF; 0402≥0.33μF(0402/X7R≥0.22μF); 0603≥0.33μF; 0805≥2.2μF; 1206≥2.2μF; 1210≥22μF	≤20%	0201≥0.1μF; 0402≥1μF; TT series; 01R5/X5R	6.3V	≤15%	≤30%	0201≥0.1μF; 0402≥1μF; 0603≥10μF; 0805≥4.7μF; 1206≥47μF; 1210≥100μF; TT series	4V	≤20%	---	---	Rated vol.	D.F. ≤	Exception of D.F. ≤		≥50V	≤7.5%	≤10%	0603≥0.1μF; 0805≥0.47μF; 1206≥4.7μF; TT series	≤20%	1210≥6.8μF	35V	≤10%	---	---	25V	≤7.5%	≤10%	0402≥0.047μF; 0603≥0.1μF; 0805≥0.33μF; 1206≥1μF; 1210≥4.7μF	≤15%	0402≥0.068μF; 0603≥0.47μF; 1206≥4.7μF; 1210≥22μF; TT series	16V (C<1.0μF)	≤10%	≤12.5%	0402≥0.068μF; 0603≥0.68μF	16V (C≥1.0μF)	≤12.5%	≤20%	0603≥2.2μF; 0805≥3.3μF; 1206≥10μF; 1210≥22μF; 1812≥47μF; TT series	≤30%	0402≥0.47μF	10V	≤20%	≤30%	0402≥0.47μF	6.3V	≤30%	---	---	Rated voltage	Insulation Resistance	100V: All X7R; 1210≥3.3μF	1GΩ or RxC≥10 Ω-F whichever is smaller.	50V: 0402>0.01μF; 0603≥1μF; 0805≥1μF; 1206≥4.7μF; 1210≥4.7μF	35V: 0603≥1μF; 0805≥2.2μF; 1206≥2.2μF; 1210≥10μF	25V: 0201≥0.1μF; 0402≥0.22μF; 0603≥2.2μF; 0805≥2.2μF; 1206≥10μF; 1210≥10μF	16V: 0201≥0.1μF; 0402≥0.22μF; 0603≥1μF; 0805≥2.2μF; 1206≥10μF; 1210≥47μF	10V: 0201≥47nF; 0402≥0.47μF; 0603≥0.47μF; 0805≥2.2μF; 1206≥4.7μF; 1210≥47μF	6.3V; 4V; TT series; All X6S/X7S items; Size≥1812; 01R5/X5R	---
Size	Dielectric	Rated voltage	Capacitance																																																																																																																																																																																																																																									
0201	X5R/X7R/X6S	≤10V	C≥0.1μF																																																																																																																																																																																																																																									
		≥16V	C>0.1μF																																																																																																																																																																																																																																									
0402	X5R	≤16V	C>1.0μF																																																																																																																																																																																																																																									
		25V, 50V	C≥1.0μF																																																																																																																																																																																																																																									
	X6S	6.3V	C>1.0μF																																																																																																																																																																																																																																									
		10V~50V	C≥1.0μF																																																																																																																																																																																																																																									
X7R/X7S/Y5V	6.3V, 10V	C≥1.0μF																																																																																																																																																																																																																																										
0603	X5R/X7R/ X6S/X7S	4V	C≥22μF																																																																																																																																																																																																																																									
		6.3V, 10V	C≥4.7μF																																																																																																																																																																																																																																									
		25V, 35V	C≥1.0μF																																																																																																																																																																																																																																									
0805	X5R/X7R/ X6S/X7S	4V	C≥47μF																																																																																																																																																																																																																																									
		6.3V	C≥22μF																																																																																																																																																																																																																																									
		10V~50V	C≥10μF																																																																																																																																																																																																																																									
1206	X5R/X7R/X6S	≤6.3V	C≥47μF																																																																																																																																																																																																																																									
1210	X5R/X7R/X6S	16V	C≥47μF																																																																																																																																																																																																																																									
	X7R	100V	C≥3.3μF																																																																																																																																																																																																																																									
TT15	X5R	6.3V	C > 1.0μF																																																																																																																																																																																																																																									
TT18	Y5V	6.3V, 10V	C≥2.2μF																																																																																																																																																																																																																																									
TT21	Y5V	6.3V	C≥10μF																																																																																																																																																																																																																																									
TT31	X5R/X7R/X6S	≤10V	C≥10μF																																																																																																																																																																																																																																									
		Y5V	6.3V	C≥22μF																																																																																																																																																																																																																																								
Size	Dielectric	Rated voltage	Capacitance																																																																																																																																																																																																																																									
0201	X5R/X6S	16V/25V	C=0.1μF																																																																																																																																																																																																																																									
	X7R	16V	C≥0.022μF																																																																																																																																																																																																																																									
0402	X5R/X7R/X6S	50V	C≥0.1μF																																																																																																																																																																																																																																									
		10~25V	C≥0.22μF																																																																																																																																																																																																																																									
0603	Y5V	16V	C≥0.47μF																																																																																																																																																																																																																																									
		50V~100V	C>0.22μF																																																																																																																																																																																																																																									
	X7S	50V	C>0.1μF																																																																																																																																																																																																																																									
		X5R	50V	C≥1.0μF																																																																																																																																																																																																																																								
X5R/X7R/ X6S/X7S	10V, 16V	C≥1.0μF																																																																																																																																																																																																																																										
	Y5V	16V	C≥2.2μF																																																																																																																																																																																																																																									
0805	X5R/X7R/ X6S/X7S	100V	C≥0.47μF																																																																																																																																																																																																																																									
		50V	C≥1.0μF																																																																																																																																																																																																																																									
		35V	C≥2.2μF																																																																																																																																																																																																																																									
	Y5V	16V	C≥4.7μF																																																																																																																																																																																																																																									
1206	X5R/X7R/ X6S/X7S	100V	C>1.0μF																																																																																																																																																																																																																																									
		50V	C=4.7μF																																																																																																																																																																																																																																									
1210	X5R/X7R/ X6S/X7S	50V~100V	C≥2.2μF																																																																																																																																																																																																																																									
1825 2220 2225	X7R	100V~250V	C≥1.0μF																																																																																																																																																																																																																																									
Rated vol.	D.F. ≤	Exception of D.F. ≤																																																																																																																																																																																																																																										
≥100V	≤3%	≤6%	1206≥0.47μF																																																																																																																																																																																																																																									
		≤7.5%	0805>0.1μF, 0603≥0.068μF, 1206>1μF; 1210≥2.2μF; TT series																																																																																																																																																																																																																																									
		≤20%	0805>0.22μF; 1210≥3.3μF																																																																																																																																																																																																																																									
50V	≤3%	≤6%	0201(50V); 0603≥0.047μF; 0805≥0.18μF; 1206≥0.47μF																																																																																																																																																																																																																																									
		≤10%	0201≥0.01μF; 1210≥4.7μF																																																																																																																																																																																																																																									
		≤20%	0402≥0.012μF; 0603>0.1μF; 0805≥1μF; 1206≥2.2μF; 1210≥10μF; TT series																																																																																																																																																																																																																																									
35V	≤5%	≤20%	0603≥1μF; 0805≥2.2μF; 1206≥2.2μF; 1210≥10μF																																																																																																																																																																																																																																									
25V	≤5%	≤10%	0201≥0.01μF; 0805≥1μF; 1210≥10μF																																																																																																																																																																																																																																									
		≤14%	0603≥0.33μF																																																																																																																																																																																																																																									
		≤15%	0201≥0.1μF; 0402≥0.10μF&(0402/X7R≥0.056μF); TT series; 0603≥0.47μF; 0805≥2.2μF; 1206≥4.7μF; 1210≥22μF																																																																																																																																																																																																																																									
		≤20%	0402≥0.47μF																																																																																																																																																																																																																																									
16V	≤5%	≤10%	0603≥0.15μF; 0805≥0.68μF; 1206≥2.2μF; 1210≥4.7μF																																																																																																																																																																																																																																									
		≤15%	0201≥0.01μF(0201/X7R≥0.022μF); 0402≥0.033μF; 0603≥0.68μF; 0805≥2.2μF; 1206≥4.7μF; 1210≥22μF; TT series																																																																																																																																																																																																																																									
10V	≤7.5%	≤15%	0201≥0.012μF; 0402≥0.33μF(0402/X7R≥0.22μF); 0603≥0.33μF; 0805≥2.2μF; 1206≥2.2μF; 1210≥22μF																																																																																																																																																																																																																																									
		≤20%	0201≥0.1μF; 0402≥1μF; TT series; 01R5/X5R																																																																																																																																																																																																																																									
6.3V	≤15%	≤30%	0201≥0.1μF; 0402≥1μF; 0603≥10μF; 0805≥4.7μF; 1206≥47μF; 1210≥100μF; TT series																																																																																																																																																																																																																																									
4V	≤20%	---	---																																																																																																																																																																																																																																									
Rated vol.	D.F. ≤	Exception of D.F. ≤																																																																																																																																																																																																																																										
≥50V	≤7.5%	≤10%	0603≥0.1μF; 0805≥0.47μF; 1206≥4.7μF; TT series																																																																																																																																																																																																																																									
		≤20%	1210≥6.8μF																																																																																																																																																																																																																																									
35V	≤10%	---	---																																																																																																																																																																																																																																									
25V	≤7.5%	≤10%	0402≥0.047μF; 0603≥0.1μF; 0805≥0.33μF; 1206≥1μF; 1210≥4.7μF																																																																																																																																																																																																																																									
		≤15%	0402≥0.068μF; 0603≥0.47μF; 1206≥4.7μF; 1210≥22μF; TT series																																																																																																																																																																																																																																									
16V (C<1.0μF)	≤10%	≤12.5%	0402≥0.068μF; 0603≥0.68μF																																																																																																																																																																																																																																									
16V (C≥1.0μF)	≤12.5%	≤20%	0603≥2.2μF; 0805≥3.3μF; 1206≥10μF; 1210≥22μF; 1812≥47μF; TT series																																																																																																																																																																																																																																									
		≤30%	0402≥0.47μF																																																																																																																																																																																																																																									
10V	≤20%	≤30%	0402≥0.47μF																																																																																																																																																																																																																																									
6.3V	≤30%	---	---																																																																																																																																																																																																																																									
Rated voltage	Insulation Resistance																																																																																																																																																																																																																																											
100V: All X7R; 1210≥3.3μF	1GΩ or RxC≥10 Ω-F whichever is smaller.																																																																																																																																																																																																																																											
50V: 0402>0.01μF; 0603≥1μF; 0805≥1μF; 1206≥4.7μF; 1210≥4.7μF																																																																																																																																																																																																																																												
35V: 0603≥1μF; 0805≥2.2μF; 1206≥2.2μF; 1210≥10μF																																																																																																																																																																																																																																												
25V: 0201≥0.1μF; 0402≥0.22μF; 0603≥2.2μF; 0805≥2.2μF; 1206≥10μF; 1210≥10μF																																																																																																																																																																																																																																												
16V: 0201≥0.1μF; 0402≥0.22μF; 0603≥1μF; 0805≥2.2μF; 1206≥10μF; 1210≥47μF																																																																																																																																																																																																																																												
10V: 0201≥47nF; 0402≥0.47μF; 0603≥0.47μF; 0805≥2.2μF; 1206≥4.7μF; 1210≥47μF																																																																																																																																																																																																																																												
6.3V; 4V; TT series; All X6S/X7S items; Size≥1812; 01R5/X5R																																																																																																																																																																																																																																												

16.	ESR	For RF Series only, refer to data sheet.	---																																																																																																																																																																																																																																									

** "Room condition" Temperature: 15 to 35°C, Relative humidity: 25 to 75%, Atmospheric pressure: 86 to 106kPa.

This Reliability Test Conditions and Requirements only for General Purpose series, please refer to individual sheet for other products information.

■ **Constructions**

No.	Name	NPO/X7R/X7S/X6S/X5R/Y5V	
①	Ceramic material	BaTiO ₃ based	
②	Inner electrode	Ni	
③	Termination	Inner layer	Cu
④		Middle layer	Ni
⑤		Outer layer	Sn

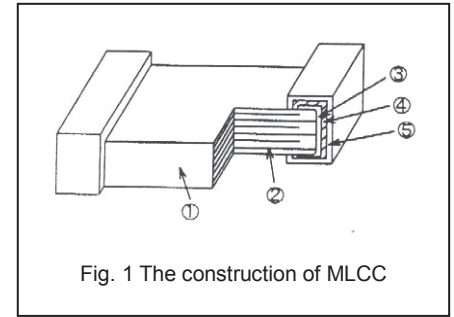

Fig. 1 The construction of MLCC

■ **Storage and handling conditions**

- (1) To store products at 5 to 40°C ambient temperature and 20 to 70% related humidity conditions.
- (2) The product is recommended to be used within one year after shipment. Check solderability in case of shelf life extension is needed.

Cautions:

- a. The corrosive gas reacts on the terminal electrodes of capacitors, and results in the poor solderability. Do not store the capacitors in the ambience of corrosive gas (e.g., hydrogen sulfide, sulfur dioxide, chlorine, ammonia gas etc.)
- b. In corrosive atmosphere, solderability might be degraded, and silver migration might occur to cause low reliability.
- c. Due to the dewing by rapid humidity change, or the photochemical change of the terminal electrode by direct sunlight, the solderability and electrical performance may deteriorate. Do not store capacitors under direct sunlight or dewing condition. To store products on the shelf and avoid exposure to moisture.

■ **Recommended soldering conditions**

The lead-free termination MLCCs are not only to be used on SMT against lead-free solder paste, but also suitable against lead-containing solder paste. If the optimized solder joint is requested, increasing soldering time, temperature and concentration of N₂ within oven are recommended.

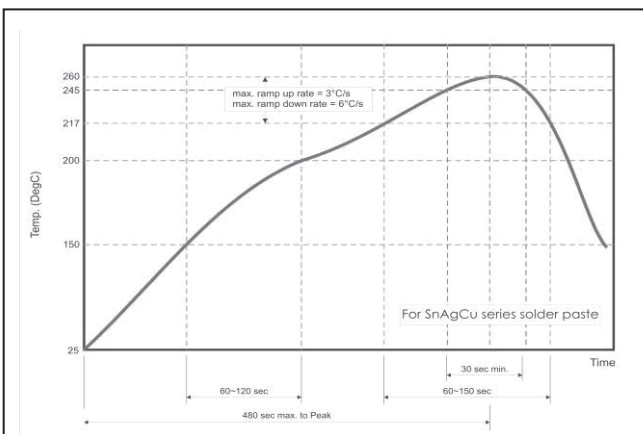

Fig. 2 Recommended reflow soldering profile for SMT process with SnAgCu series solder paste.

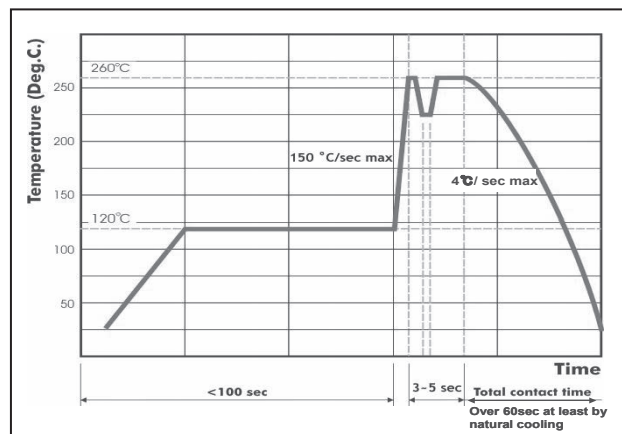

Fig. 3 Recommended wave soldering profile for SMT process with SnAgCu series solder.

Taiwan - Yang-Mei Plant / Sales Office

Walsin Technology Corporation
566-1, Kao-Shi Road, Yang-Mei, Tao-Yuan, Taiwan
Tel: +886-3-475-8711 Fax: +886-3-475-7130 Email: info@passivecomponent.com

China - Dalang Plant / Sales Office

Dongguan Walsin Tech. Electronics CO., Ltd.
Xiniu Administrative Zone, Dalang Town, Dongguan City, Guangdong Province 523799
Tel: +86-769-831-15168 Fax: +86-769-831-15188 Email: msyu@passivecomponent.com

China - Suzhou Plant / Sales Office

Suzhou Walsin Technology Electronics Co., Ltd.
No. 369, Changyan Street, Suzhou Industrial Park, Jiangsu Province 215126
Tel: +86-512-628-36888 Fax: +86-512-628-37888 Email: msyu@passivecomponent.com

China - Guangzhou Plant / Sales Office

Pan Overseas (Guangzhou) Electronic Co., Ltd.
No. 277, Hong Ming Road, Eastern Section, Guangzhou Economic and Technology, Development Zone, China
Tel: +86-20-8223-7476 Fax: +86-20-8223-7475 Email: msyu@passivecomponent.com

Germany - Munich Sales Office

Walsin Technology Corporation Europe
Stefan-George-Ring 2, 81929 München, Germany
Tel: +49-(0)89-9308-6475 Fax: +49-(0)89-9308-6464 Email: aw@passivecomponent.com

Singapore - Sales Office

WTC Singapore Sales Office, Singapore
24 Sin Ming Lane Midview City, #04-100, Singapore 573970
Contact: Morris Liew
Tel: +65-6262 3997 Email: morrisliew@sg.passivecomponent.com

Malaysia - Sales Office

Walsin Technology Corporation, Malaysia
1st Floor, No.19, Jalan Puteri 5/8, Bandar Puteri Puchong, Puchong, 47100, Selangor, Malaysia
Contact: Arthur Ling
Tel: +6016-2217-948 Fax: +603-8051-7060 Email: arthurling@passivecomponent.com

United States - West Coast Sales Office

Walsin Technology Corporation, USA
Contact: FC Tseng
Tel: +1-214-708-5182 E-mail: fctsen@passivecomponent.com

JAPAN - Sales Office

PSA BLDG. 3F, 6-1-6 Chuou, Yamato-Shi, Kanagawa, 242-0021 Japan
Tel: +81-46-204-8829 Fax: +81-46-204-8955 Email: tsakano@kamaya.co.jp

PSA PASSIVE SYSTEM ALLIANCE
WALSIN TECHNOLOGY CORPORATION

TAIWAN - WTC Yang-Mei Plant / Sales Office

566-1, Kao-Shi Road, Yang-Mei, Tao-Yuan, Taiwan

Tel: +886-3-475-8711

Fax: +886-3-475-7130

Email: info@passivecomponent.com



Aug. 2018

Looking for pricing, stock, or lifecycle information?

Click below to explore more details on WIN SOURCE:

- [View 0402X104K100CT on WIN SOURCE](#)
- [Walsin Technology Corporation Information](#)

Optimize Your Supply Chain with WIN SOURCE Solutions

- ✓ Global Sourcing Solution
- ✓ Obsolete Management
- ✓ Cost Control Management
- ✓ Shortage Management
- ✓ Alternative Solution
- ✓ Excess Inventory Management