

TB6549FG, TB6549PG, TB6549HQ

Full-Bridge Driver IC for DC Motors

The TB6549FG/PG/HQ is a full-bridge driver IC for DC motors that uses an LDMOS structure for output transistors. High-efficiency drive is possible through the use of a MOS process with low ON-resistance and a PWM drive system. Four modes, CW, CCW, short brake, and stop, can be selected using IN1 and IN2.

Features

- Power supply voltage: 30 V (max)
- Output current: 3.5 A (max) (FG,PG type)/4.5 A (max) (HQ type)
- Low ON-resistance: 1.0 Ω (up + low/typ.)
- PWM control capability
- Standby system
- Function modes: CW/CCW/short brake/stop
- Built-in overcurrent protection
- Built-in thermal shutdown circuit
- Package: HSOP20/DIP16/HZIP25

About solderability, the following conditions were confirmed

(1)Use of Sn-37Pb solder Bath
 ·solder bath temperature: 230°C
 ·dipping time: 5 seconds
 ·the number of times: once
 ·use of R-type flux

(2)Use of Sn-3.0Ag-0.5Cu solder Bath
 ·solder bath temperature: 245°C
 ·dipping time: 5 seconds
 ·the number of times: once
 ·use of R-type flux

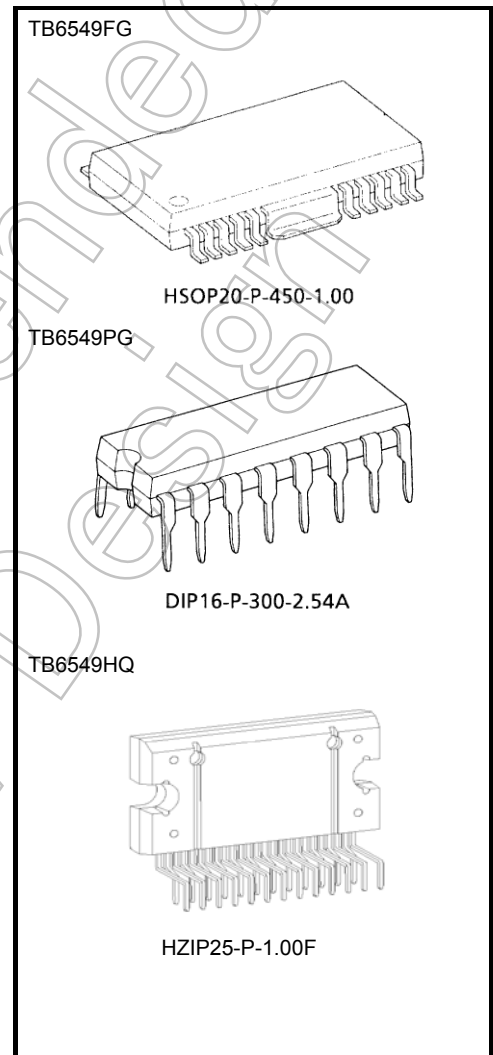

Weight
 HSOP20-P-450-1.00: 0.79 g (typ.)
 DIP16-P-300-2.54A: 1.11 g (typ.)
 HZIP25-P-1.00F: 7.7g (typ.)

Note: This product has a MOS structure and is sensitive to electrostatic discharge. When handling this product, ensure that the environment is protected against electrostatic discharge by using an earth strap, a conductive mat and an ionizer. Ensure also that the ambient temperature and relative humidity are maintained at reasonable levels.

Pin Assignment

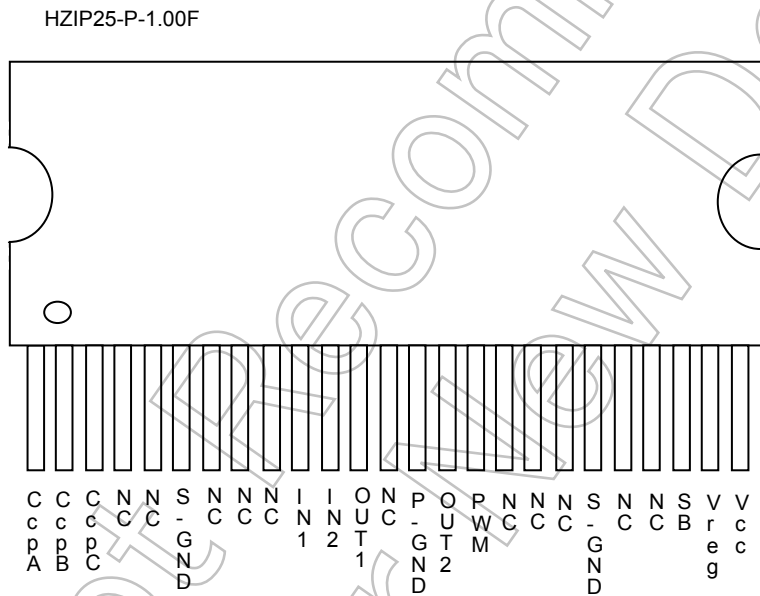
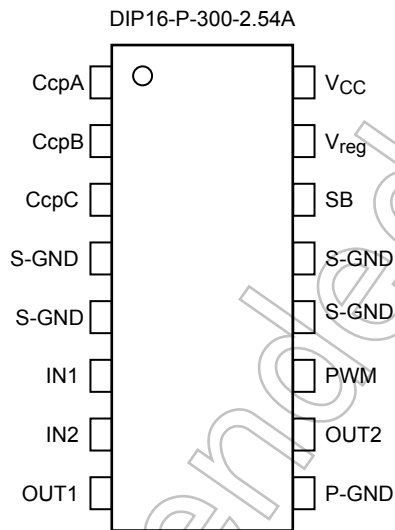
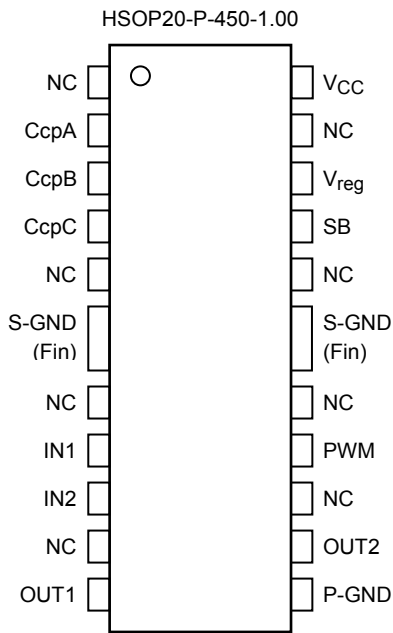

Block Diagram

Some functional blocks, circuits or constants may be omitted or simplified in this block diagram for explanatory purposes.

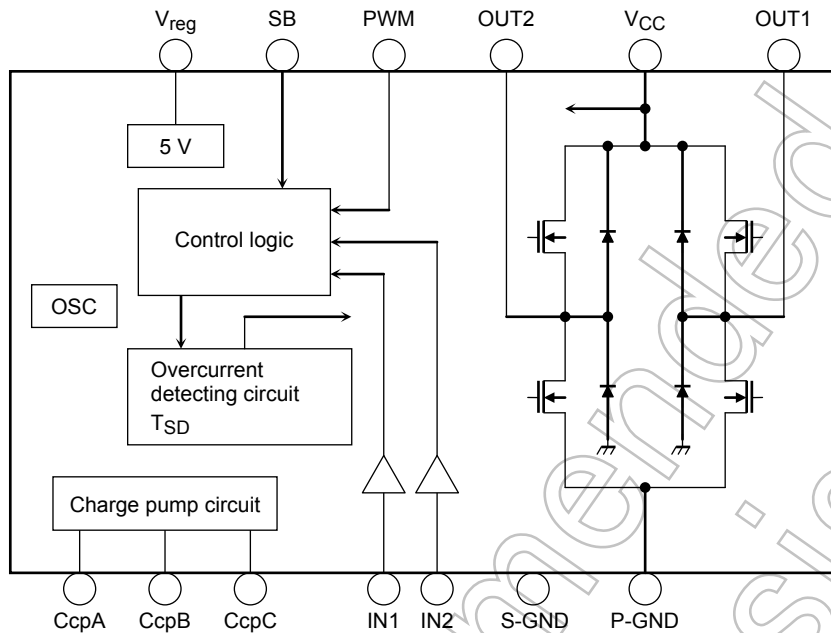

Pin Functions

Pin No.			Pin Name	Functional Description	Remarks
FG	PG	HQ			
1	—	—	(NC)	No Connection	—
2	1	1	CcpA	Capacitor connection pin for charge pump A	Connect a capacitor for charge pump
3	2	2	CcpB	Capacitor connection pin for charge pump B	Connect a capacitor for charge pump
4	3	3	CcpC	Capacitor connection pin for charge pump C	Connect a capacitor for charge pump
5	—	—	(NC)	No Connection	—
6	—	—	(NC)	No Connection	—
7	6	10	IN1	Control signal input 1	Input 0/5-V signal
8	7	11	IN2	Control signal input 2	Input 0/5-V signal
9	—	—	(NC)	No Connection	—
10	8	12	OUT1	Output pin 1	Connect to motor coil pin
11	9	14	P-GND	Power GND	—
12	10	15	OUT2	Output pin 2	Connect to motor coil pin
13	—	—	(NC)	No Connection	—
14	11	16	PWM	PWM control signal input pin	Input 0/5-V PWM signal
15	—	—	(NC)	No Connection	—
16	—	—	(NC)	No Connection	—
17	14	23	SB	Standby pin	H: Start, L: Standby
18	15	24	V _{reg}	5 V output pin	Connect a capacitor to S-GND
19	—	—	(NC)	No Connection	—
20	16	25	V _{CC}	Power supply input pin	V _{CC (ope)} = 10 to 27 V
FIN	4,5,12,13	6, 20	S-GND	GND pin	—

*) (HQ type) 4, 5, 7, 8, 9, 13, 17, 18, 19, 21, 22 ;N.C.

Absolute Maximum Ratings (T_a = 25°C)

Characteristic		Symbol	Rating	Unit
Supply voltage		V _{CC}	30	V
Output current	I _O (Pulse)	FG, PG	3.5 (Note1)	A
		HQ	4.5 (Note2)	
	I _O (DC)	FG, PG	2.0	
		HQ	3.5	
Input voltage		V _{in}	-0.3 to 5.5	V
Power dissipation	FG	P _D	2.5 (Note3)	W
	PG		2.7 (Note4)	
	HQ		3.2 (Note5)	
			40 (Note6)	
Operating temperature		T _{opr}	-20 to 85	°C
Storage temperature		T _{stg}	-55 to 150	°C

Note1: The absolute maximum ratings must be observed strictly. Make sure that no characteristic listed above ever exceeds the absolute maximum rating.

Note2: t = 100 ms

Note3: This value is obtained for a 115 mm × 75 mm × 1.6 mm PCB mounting with 30% copper area.

Note4: This value is obtained for a 50 mm × 50 mm × 1.6 mm PCB mounting with 50% copper area.(Glass epoxy board)

Note5: IC only.

Note6: Infinite heat sink.

Operating Ranges (T_a = 25°C)

Characteristic	Symbol	Rating	Unit
Supply voltage	V _{CC}	10 to 27	V
PWM frequency	f _{CLK}	100	kHz

Electrical Characteristics (V_{CC} = 24 V, T_a = 25°C)

Characteristic		Symbol	Test Circuit	Test Condition	Min	Typ.	Max	Unit	
Supply current		I _{CC1}	1	Stop mode	—	4	8	mA	
		I _{CC2}		CW/CCW mode	—	6	10		
		I _{CC3}		Short brake mode	—	4	8		
		I _{CC4}		Standby mode	—	1	2		
Control circuit		V _{INH}	2		2	—	5.5	V	
		V _{INL}			0	—	0.8		
		Hysteresis voltage	V _{IN (HYS)}	—	(Not tested)	—	0.2	—	μA
		Input current	I _{INH}	1	V _{IN} = 5 V	—	50	75	
	I _{INL}	V _{IN} = 0 V	—		—	5			
PWM input circuit		V _{PWMH}	3		2	—	5.5	V	
		V _{PWML}			—	—	0.8		
		Hysteresis voltage	V _{PWM(HYS)}	—	(Not tested)	—	0.2	—	μA
		Input current	I _{PWMH}	3	V _{PWM} = 5 V	—	50	75	
			I _{PWML}		V _{PWM} = 0 V	—	—	5	
	PWM frequency	f _{PWM}	3	Duty = 50%	—	—	100	kHz	
	Minimum clock pulse width	tw(PWM)	3		2	—	—	μs	
Standby circuit		V _{INSH}	2		2	—	5.5	V	
		V _{INSL}			—	—	0.8		
		Hysteresis voltage	V _{IN (HYS)}	—	(Not tested)	—	0.2	—	μA
		Input current	I _{INSH}	1	V _{IN} = 5 V	—	50	75	
	I _{INSL}	V _{IN} = 0 V	—		—	5			
Output ON-resistance		R _{on (U + L)}	4		I _O = 0.2 A	—	1.0	1.75	Ω
					I _O = 1.5 A	—	1.0	1.75	
Output leakage current		I _{L (U)}	5	V _{CC} = 30 V (Note 1)	—	—	150	μA	
		I _{L (L)}			V _{CC} = 30 V	—	—		10
Diode forward voltage		V _{F (U)}	6	I _O = 1.5 A	—	1.3	1.7	V	
		V _{F (L)}			I _O = 1.5 A	—	1.3		1.7
Internal reference voltage		V _{reg}	4	No load	4.5	5	5.5	V	
Overcurrent detection offset time		I _{SD (OFF)}	—	(Not tested)	—	50	—	μs	
Charge pump rising time		t _{ONG}	7	C ₁ = 0.22 μF, C ₂ = 0.01 μF (Note 2)	—	1	3	ms	
Thermal shutdown circuit operating temperature		T _{SD}	—	(Not tested)	—	160	—	°C	

Note 1: Include the current in the circuit.

Note 2: C₁ is a capacitor between CcpA and GND. C₂ is a capacitor between CcpB and CcpC.

Component Description

1. Control Input/PWM Input Circuit

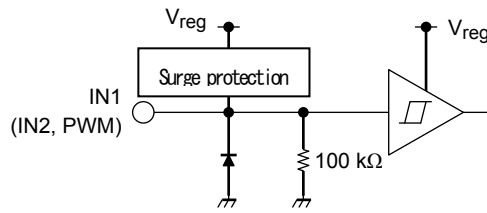

- The input signals are shown below. Input at the CMOS and TTL levels can be provided. Note that the input signals have a hysteresis of 0.2 V (typ.).
 V_{INH} : 2 to 5.5 V
 V_{INL} : GND to 0.8 V
- The PWM input frequency should be 100 kHz or less.

Input/Output Function

Input				Output		
IN1	IN2	SB	PWM	OUT1	OUT2	Mode
H	H	H	H	L	L	Short brake
			L			
L	H	H	H	L	H	CW/CCW
			L	L	L	Short brake
H	L	H	H	H	L	CCW/CW
			L	L	L	Short brake
L	L	H	H	OFF (high impedance)		Stop
			L			
H/L	H/L	L	H	OFF (high impedance)		Standby
			L			

- PWM control function**
 Motor speed can be controlled by inputting the 0/5-V PWM signal to the PWM pin.
 When PWM control is provided, normal operation and short brake operation are repeated.
 If the upper and lower power transistors in the output circuit were ON at the same time, a penetrating current would be produced. To prevent this current from being produced, a dead time of 300 ns (design target value) is provided in the IC when either of the transistors changes from ON to OFF, or vice versa. Therefore, PWM control by synchronous rectification is enabled without an OFF time being inserted by external input. Note that a dead time is also provided in the IC at the time of transition between CW and CCW or between CW (CCW) and short brake mode, thereby eliminating the need for an OFF time.

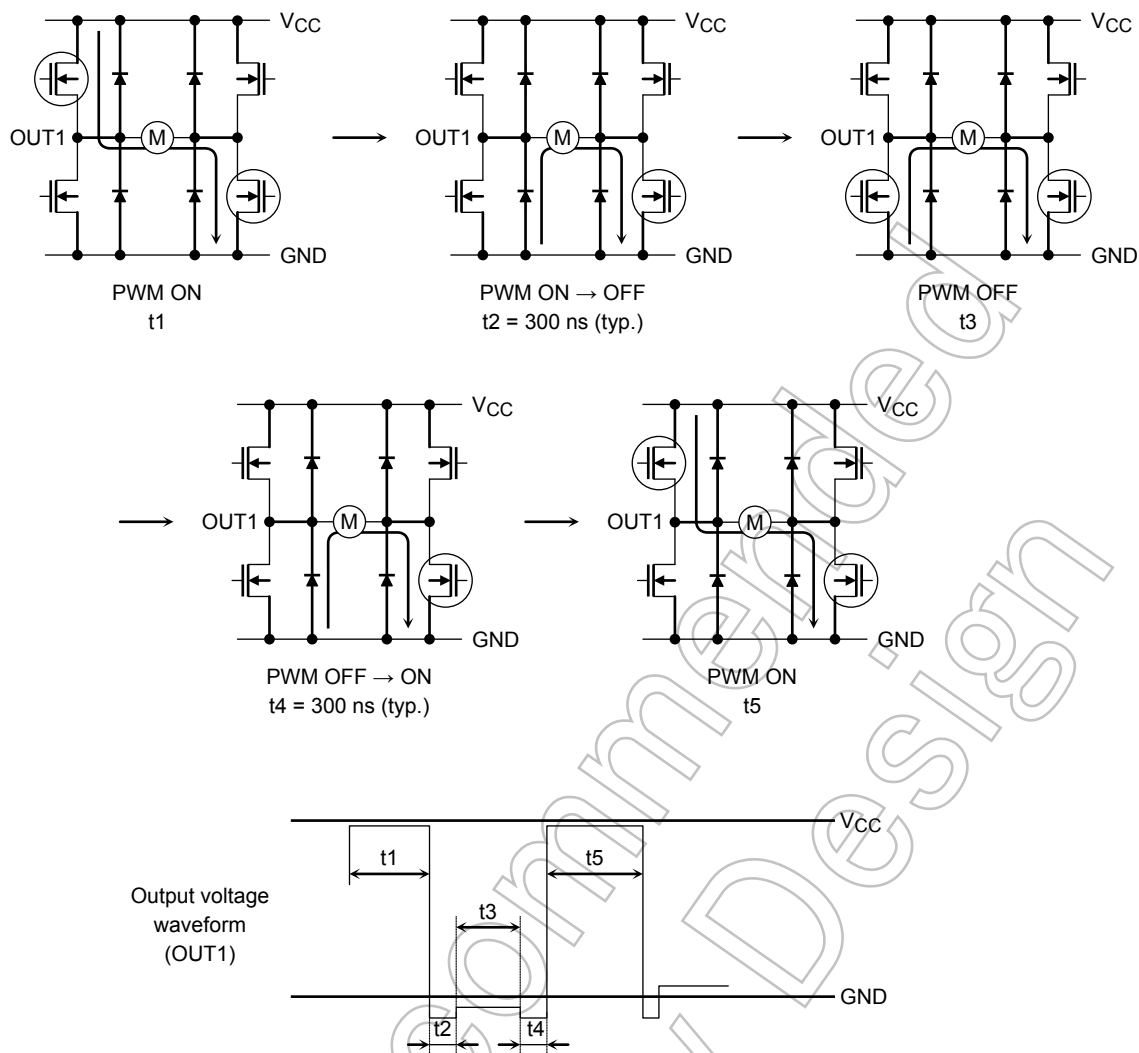

Note: Be sure to set the pin PWM to High when the PWM control function is not used.

2. Standby Circuit

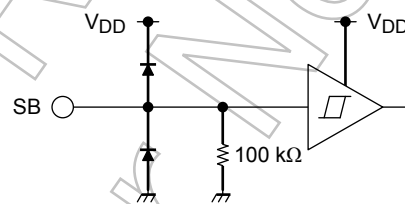

- All circuits are turned off except the standby circuit and the charge pump circuit under the standby condition.
- The input voltage range is shown below. Input at CMOS and TTL level is possible. The input signal has 0.2 V (typ.) hysteresis.
 V_{INSH} : 2 to V_{reg} V
 V_{INSL} : GND to 0.8 V
- Do not attempt to the control the output by inputting PWM signals to the standby pin. Doing so may cause the output signal to become unstable, resulting in destruction of the IC. (The charge pump circuit is turned ON/OFF by the switch of the input signal from the standby pin. If the switching cycle is shorter than 50 ms, the charge pump circuit will not operate with precise timing. Therefore the switching cycle of the standby pin should be longer than 50 ms.) When the Standby condition is changed to Operation Mode, set IN1 and IN2 to Low level (Stop Mode) at first. Then switch IN1 and IN2 to High level when the charge pump circuit reaches the stable condition, i.e., when V_{cpA} is about $V_{CC} + 5 \text{ V}$.

3. Internal Constant-Voltage (5 V) Circuit

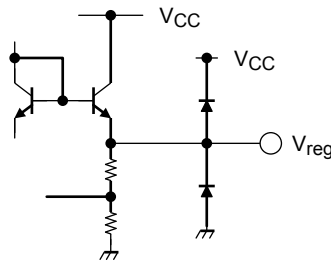

- This IC includes a 5 V power supply for control circuit.
- A capacitor for prevention of oscillation should be connected to S-GND associated with the pin V_{reg}. No other loads should be connected to pin V_{reg}.
- This IC has a power monitoring function and turns the output OFF when V_{reg} goes down to 3.0 V (design target value) or less. With a hysteresis of 0.3 V (design target value), the output are turned ON when V_{reg} again reaches 3.3 V (design target value).

4. Charge Pump Circuit

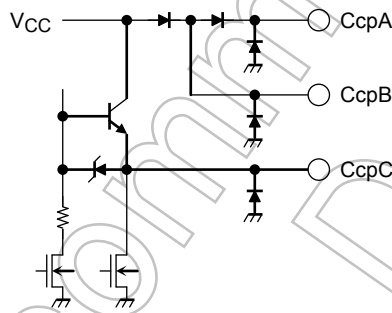

- This IC has a charge pump circuit for driving the gate for the upper power transistor in the output circuit. A voltage of V_{CC} + 5 V (typ.) is generated by connecting an external capacitor to this IC. It takes about 2 ms to boost V_{cpA} up V_{CC} + 5 V (typ.) after the switching of the input signal from the standby pin (while C_{cpA} = 0.22 μF, and C_{cpB} and C_{cpC} are connected through 0.01 μF).
- The proper capacitance of the external capacitor varies depending on the V_{CC} value. Thus, determine the constant by referring to the following data. The value of the capacitor between C_{cpB} and C_{cpC} should be such that, while the motor is being driven, the voltage on the C_{cpA} pin will be kept constant, typically at V_{CC} + 5 V. (If a reduced V_{CC} level causes the voltage on C_{cpA} to start to fall, please adjust this capacitance value accordingly.)

<External capacitor>

V _{CC}	Between C _{cpB} and C _{cpC}	Between C _{cpA} and GND
10 V to 20 V	0.01 μF to 0.047 μF	0.22 μF
20 V to 27 V	0.01 μF	0.22 μF

- Reference oscillation is performed by using the internal capacitor.

5. Output Circuit

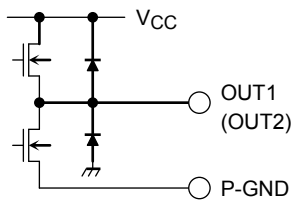

- This IC uses Nch MOS transistors as the upper and lower transistors in the output circuit.
- As output R_{on} is $1\ \Omega$ (sum for the upper and lower parts/typ.), this IC is a device of the low- R_{on} type.
- The switching characteristics of the output transistors are shown below.

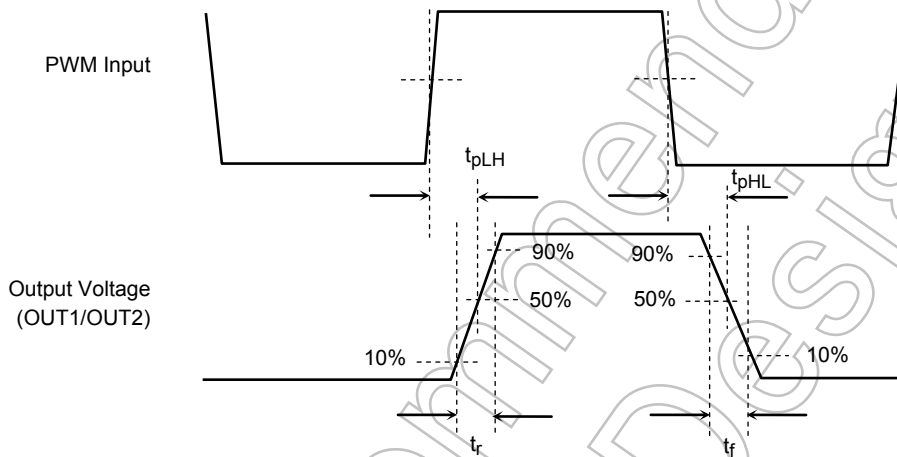

<Typical Value>

Item	Typical Value	Unit
t_{pLH}	350	ns
t_{pHL}	800	
t_r	60	
t_f	100	

<Actual Measured Waveform>

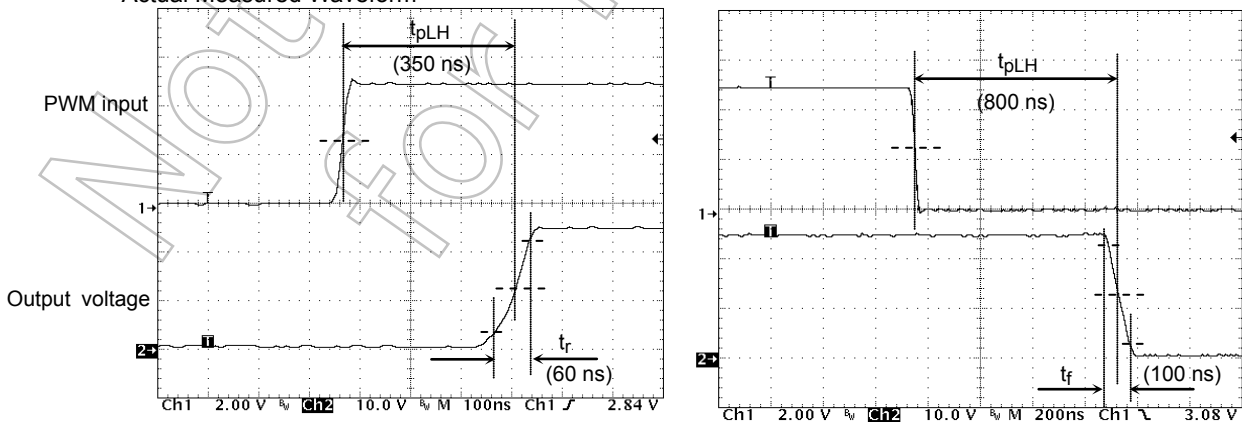

*: OUT 1, OUT 2; open

6. V_{CC} Power Supply Section

- The V_{CC} power supply delivers a voltage to the output circuit, charge pump circuit, and internal 5 V circuit.
- The operating voltage range is shown below:
 $V_{CC (opr.)} = 10 \text{ to } 27 \text{ V}$
- This IC has a power monitoring function for preventing an output malfunction on power-up. However, Toshiba recommends that IN1, IN2, and SB be set to the Low level at power-on.

7. GND Sections

- This IC includes two separate GND sections: S-GND for controlling and P-GND for outputting. Be sure to short-circuit these two GNDs as close to TB6549 as possible.

8. Power Monitoring Circuit

- This circuit turns the output OFF when V_{reg} becomes 3.0 V (design target value) or less. At this time, V_{CC} = 4.6 V (typ.).
- With a hysteresis of 0.3 V (design target value), the output turns back ON when V_{reg} exceeds 3.3 V (design target value) after this circuit starts operating.

9. Thermal Shutdown (T_{SD}) Circuit

This IC includes a thermal shutdown circuit, which turns the output OFF when the junction temperature (T_j) exceeds 160°C (typ.). The output turns back ON automatically. The thermal hysteresis is 20°C.

$$T_{SD} = 160^{\circ}\text{C} \text{ (design target value)}$$

$$\Delta T_{SD} = 20^{\circ}\text{C} \text{ (design target value)}$$

10. Overcurrent Detection (I_{SD}) Circuit

This IC includes a circuit to detect current flowing through the output power transistors. The current limit is set to 5 A (typ.). The circuit detects a current flowing through each of the four output power transistors. If the current in any one output power transistor exceeds the set limit, this circuit turns all the outputs OFF.

This circuit includes a timer that causes the outputs to be OFF for 50 μs (typ.) after detection of an overcurrent and then turn back ON automatically. If the overcurrent continues to flow, this ON-OFF operation is repeated. Note that to prevent a malfunction due to a glitch, an insensitive period of 10 μs (typ.) is provided.

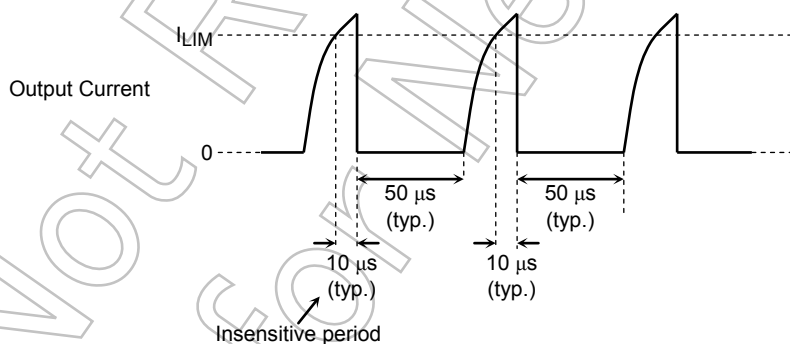

The set limit is 5 A (typ.) as a design target value. The distributions shown below exist because of the variations in thermal characteristics of different ICs. These distributions should be fully considered in the motor torque design.

Also, output peak current should be less than 3 A because of the variations below,

Detected current: Approximately from 3.5 to 6.5 A

Test Circuit

1. I_{CC1} , I_{CC2} , I_{CC3} , I_{CC4} , I_{INH} , I_{INL} , I_{INSH} , I_{INSL}

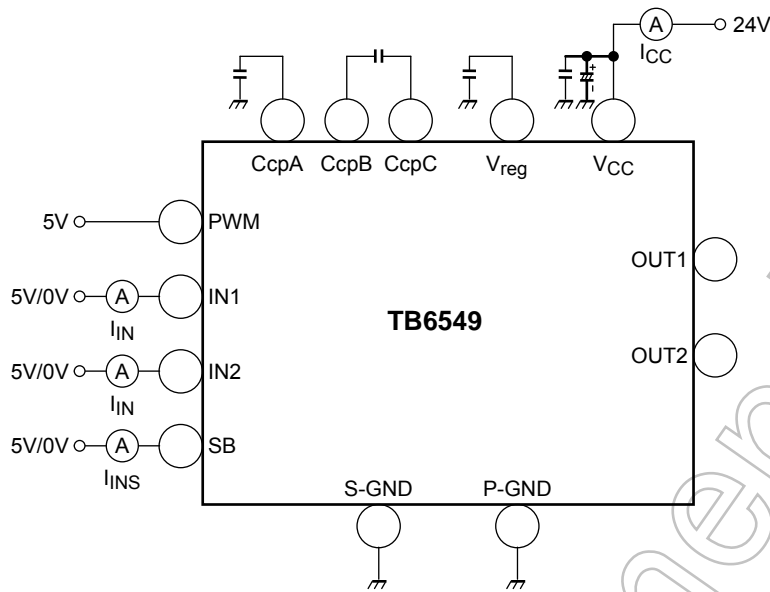

- I_{CC1} : $IN1 = 0\text{ V}$, $IN2 = 0\text{ V}$, $SB = 5\text{ V}$
- I_{CC2} : $IN1 = 5\text{ V}$, $IN2 = 5\text{ V}$, $SB = 5\text{ V}$ or $IN1 = 0\text{ V}$, $IN2 = 5\text{ V}$, $SB = 5\text{ V}$
- I_{CC3} : $IN1 = 5\text{ V}$, $IN2 = 5\text{ V}$, $SB = 5\text{ V}$
- I_{CC4} : $IN1 = 5\text{ V}/0\text{ V}$, $IN2 = 5\text{ V}/0\text{ V}$, $SB = 0\text{ V}$
- I_{INH} : $IN1 = 5\text{ V}$, $IN2 = 5\text{ V}$
- I_{INL} : $IN2 = 0\text{ V}$, $IN2 = 0\text{ V}$
- I_{INSH} : $SB = 5\text{ V}$
- I_{INSL} : $SB = 0\text{ V}$

2. V_{INH} , V_{INL} , V_{INSH} , V_{INSL}

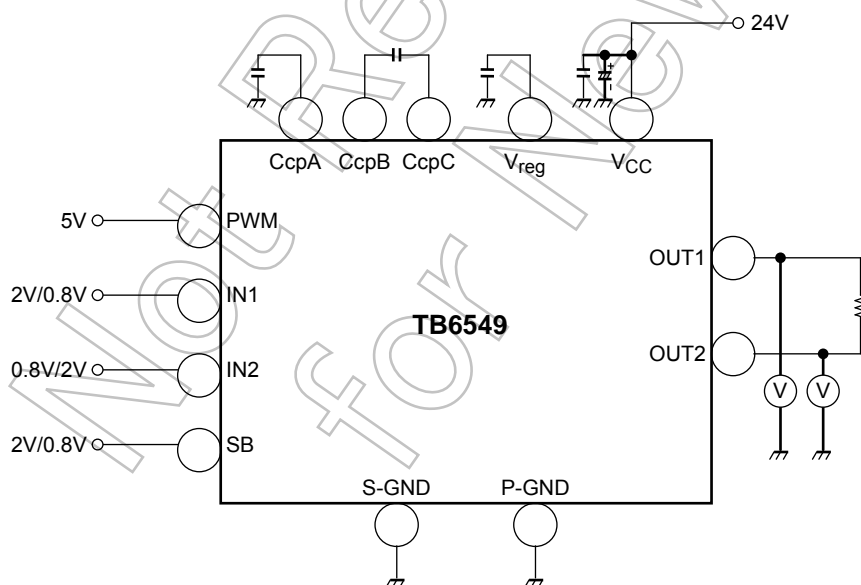

- V_{INH} , V_{INSH} : $IN1 = IN2 = SB = 2\text{ V}$. Verify that $OUT1 = OUT2 = L$.
- V_{INL} : $IN1 = 0.8\text{ V}$, $IN2 = SB = 2\text{ V}$. Verify that $OUT1 = L$, $OUT2 = H$. $IN1 = SB = 2\text{ V}$, $IN2 = 0.8\text{ V}$. Verify that $OUT1 = OUT2 = L$.
- V_{INSL} : $IN1 = IN2 = 2\text{ V}$, $SB = 0.8\text{ V}$. Verify that the output function is high impedance.

3. V_{PWMH} , V_{PWML} , I_{PWMH} , I_{PWML} , f_{PWM} , t_w (PWM)

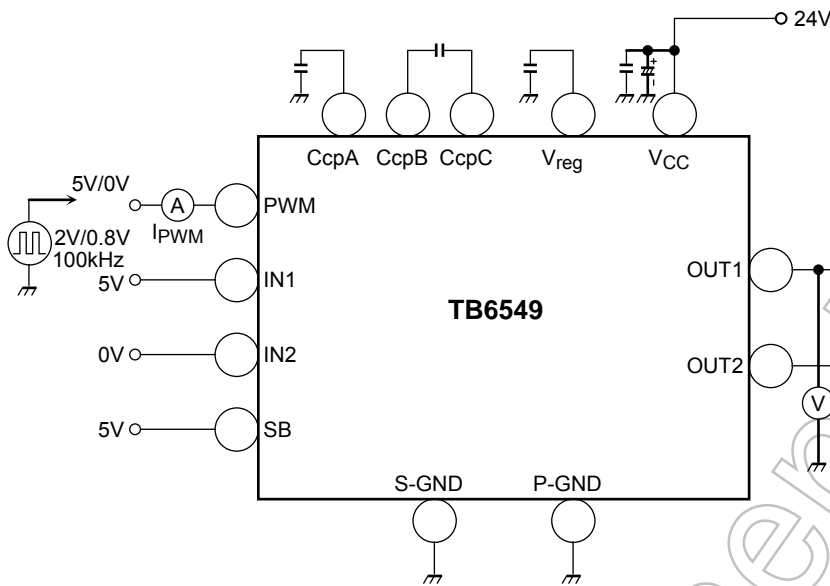

- V_{PWMH} , V_{PWML} , f_{PWM} : PWM = 2 V/0.8 V, 100 kHz; duty: 50 % (rectangular wave). Verify OUT1.
- V_{PWMH} , V_{PWML} : PWM = 5 V or PWM = 0 V.
- t_w (PWM): PWM = 2 V/0.8 V, 100 kHz; duty: 20 % (2 μ s) (2 μ s/rectangular wave). Verify OUT1.

4. R_{on} (U + L), V_{reg}

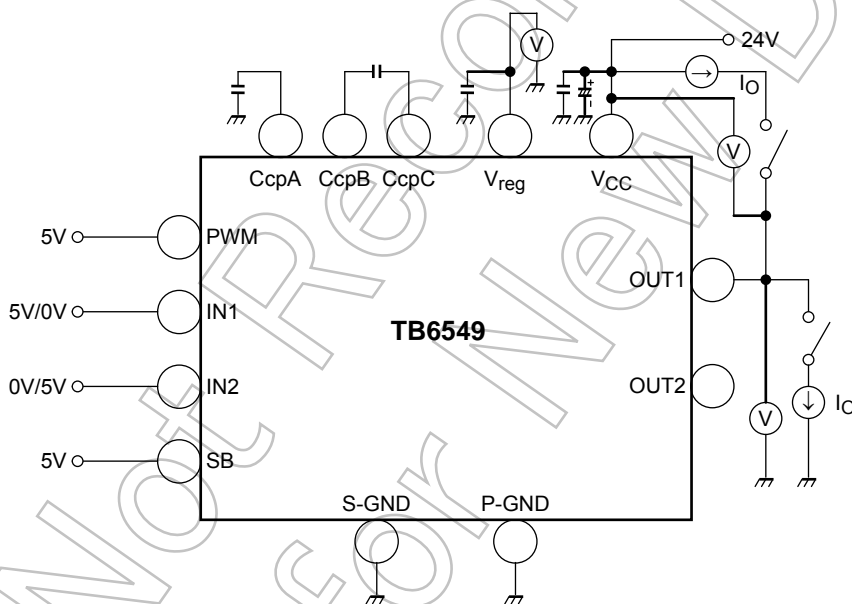

- R_{on} (U + L): Measure V_{ds} (the sum of upper and lower sides) at $I_o = 0.2$ A, and convert to resistor. Do the same at $I_o = 1.5$ A. Measured for OUT1 and OUT2.
- V_{reg} : V_{reg} pin voltage.

5. $I_L(U)$, $I_L(L)$

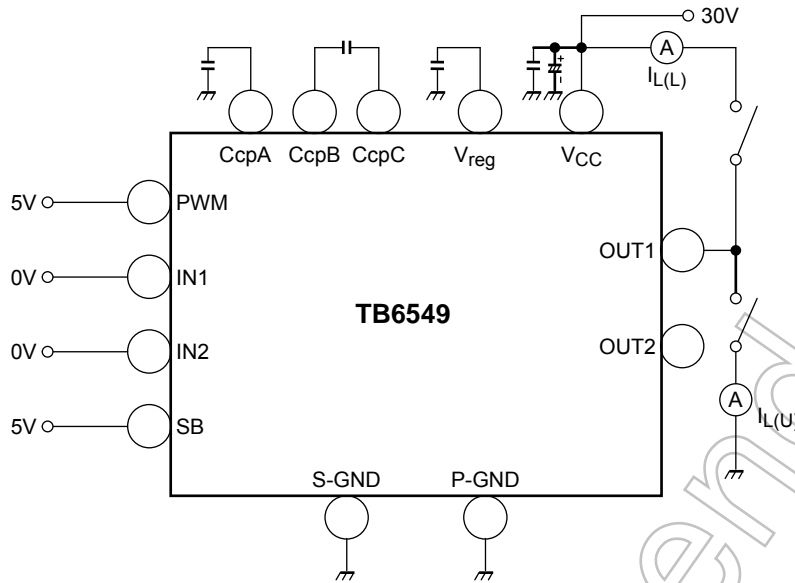

6. $V_F(U)$, $V_F(L)$

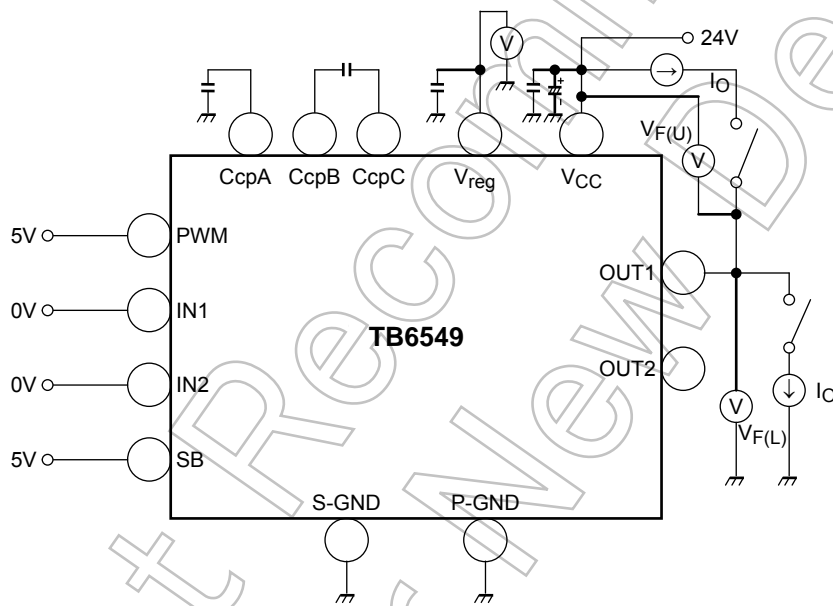

- $V_F(U)$, $V_F(L)$: $I_o = 1.5\text{ A}$.

7. t_{ONG}

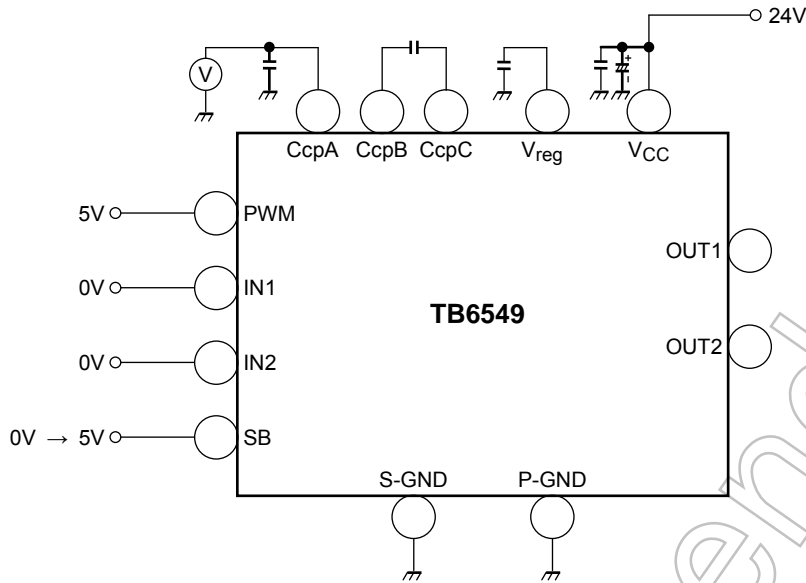

- t_{ONG}: SB = 0 V → 5 V. Measure the time taken to boost the CcpA voltage up to about 29 V (24 V + 5 V).

Not Recommended for New Design

Characteristics Curves

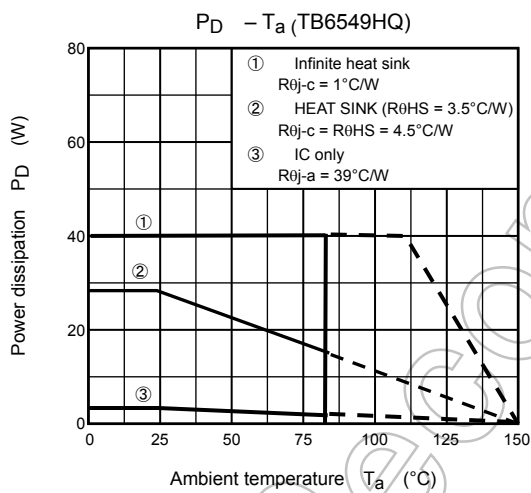
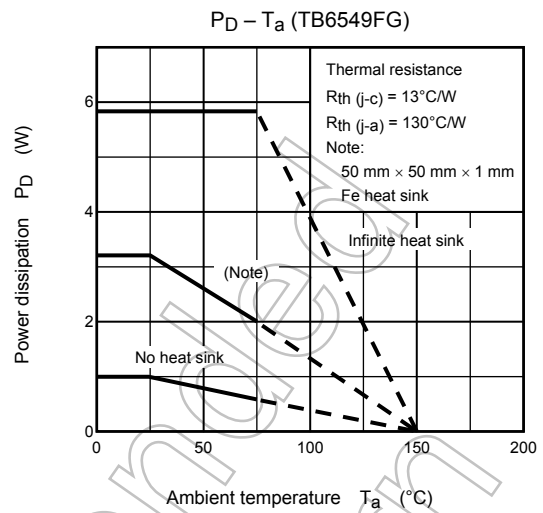
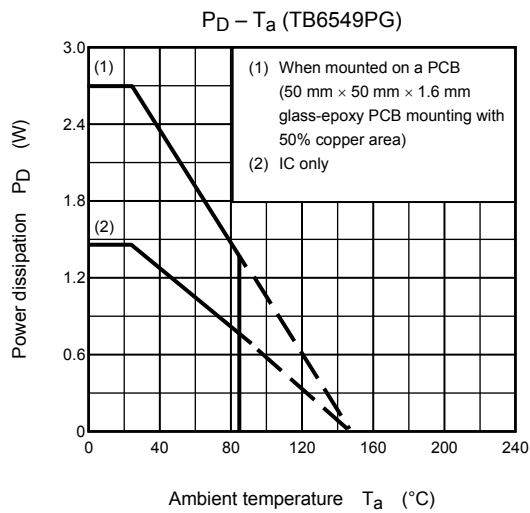

External Attachments

Symbol	Use	Recommended Value	Remarks
C ₁	Charge pump	0.22 μF	—
C ₂	Charge pump	0.01 μF	$V_{CC} = 24 \text{ V}$ (Note)
		0.033 μF	$V_{CC} = 12 \text{ V}$ (Note)
C ₃	Prevention of V_{reg} oscillation	0.1 μF to 1.0 μF	—
C ₄	Absorption of power noise	0.1 μF to 1.0 μF	—
C ₅	Absorption of power noise	50 μF to 100 μF	—

Note: The recommended values for charge pumps depend on the V_{CC} value. Refer to Component Description 4, Charge Pump Circuit.

Typical Application Diagram

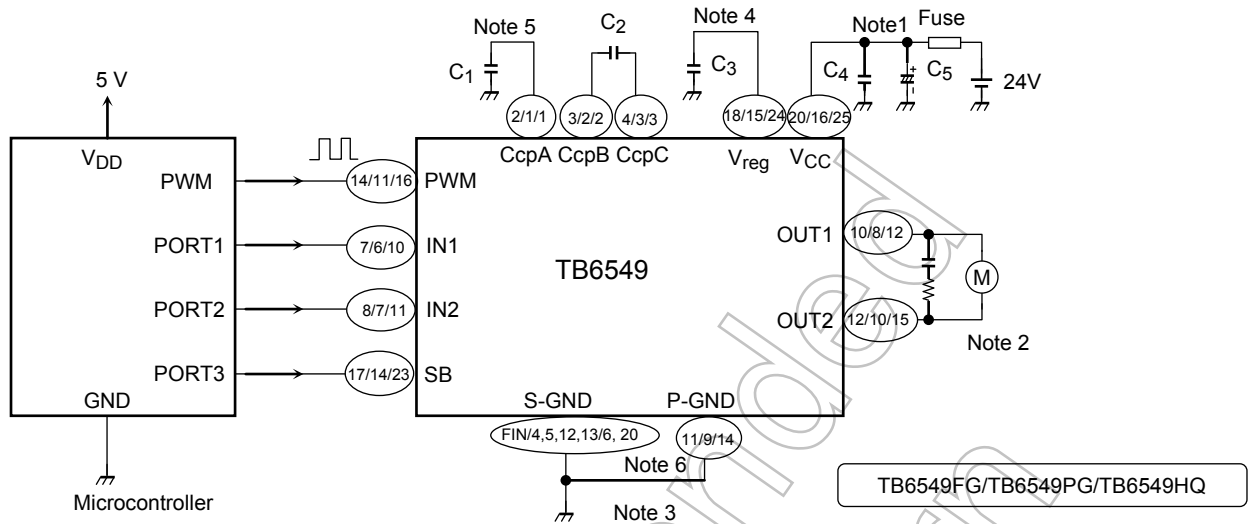

TB6549FG: Pins 1, 5, 6, 9, 13, 15, 16, and 19 are not connected.

TB6549HQ: Pins 4, 5, 7, 8, 9, 13, 17, 18, 19, 21, and 22 are not connected.

- Note 1: Connect V_{CC} and P-GND through the power supply capacitor. This capacitor should be as close as possible to the IC.
- Note 2: When connecting the motor pins through the capacitor for reducing noise, connect a resistor to the capacitor for limiting the charge current. The switching loss increases for PWM control. Therefore, whenever practicable, avoid connecting the capacitor if PWM control is required.
- Note 3: Short-circuit S-GND and P-GND as close to the TB6549 as possible.
- Note 4: Connect the capacitor C_3 to S-GND.
- Note 5: Connect the capacitors C_1 and C_2 as close to the TB6549 as possible, and the capacitor C_1 as close to S-GND.
- Note 6: Pins 4, 5, 12, and 13 of the PG type are connected to the bed of the chip. Therefore expanding the round area of these pins improves the heat radiation effect.

Usage Precautions

- Utmost care is necessary in the design of the output, V_{CC} , and GND lines since the IC may be destroyed by short-circuiting between outputs, air contamination faults, or faults due to improper grounding, or by short-circuiting between contiguous pins.
- Be sure to install the IC correctly. The IC may be destroyed if installed wrongly (e.g., in reverse).

Package Dimensions

HSOP20-P-450-1.00

Unit : mm

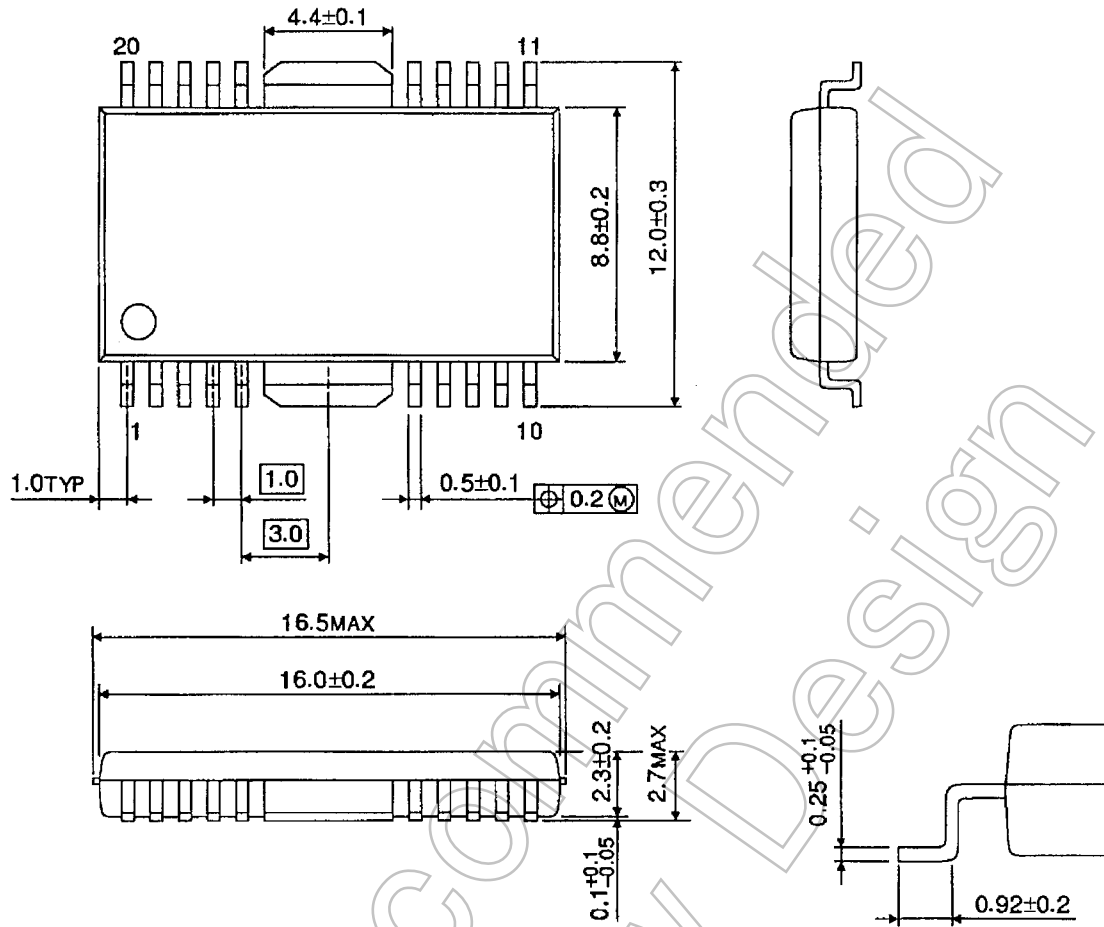

Weight: 0.79 g (typ.)

Not Recommended for New Design

Package Dimensions

DIP16-P-300-2.54A

Unit : mm

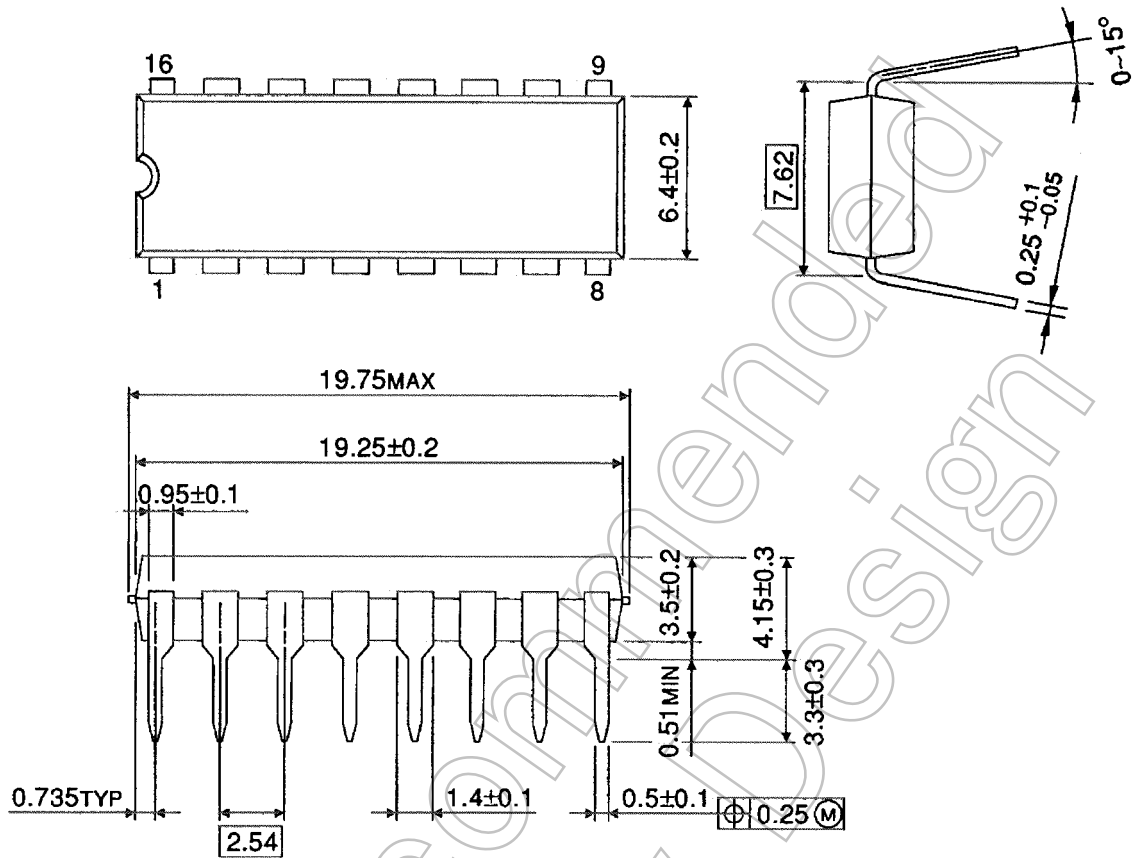

Weight: 1.11 g (typ.)

Not Recommended for New Design

Package Dimensions

HZIP25-P-1.00F

Unit: mm

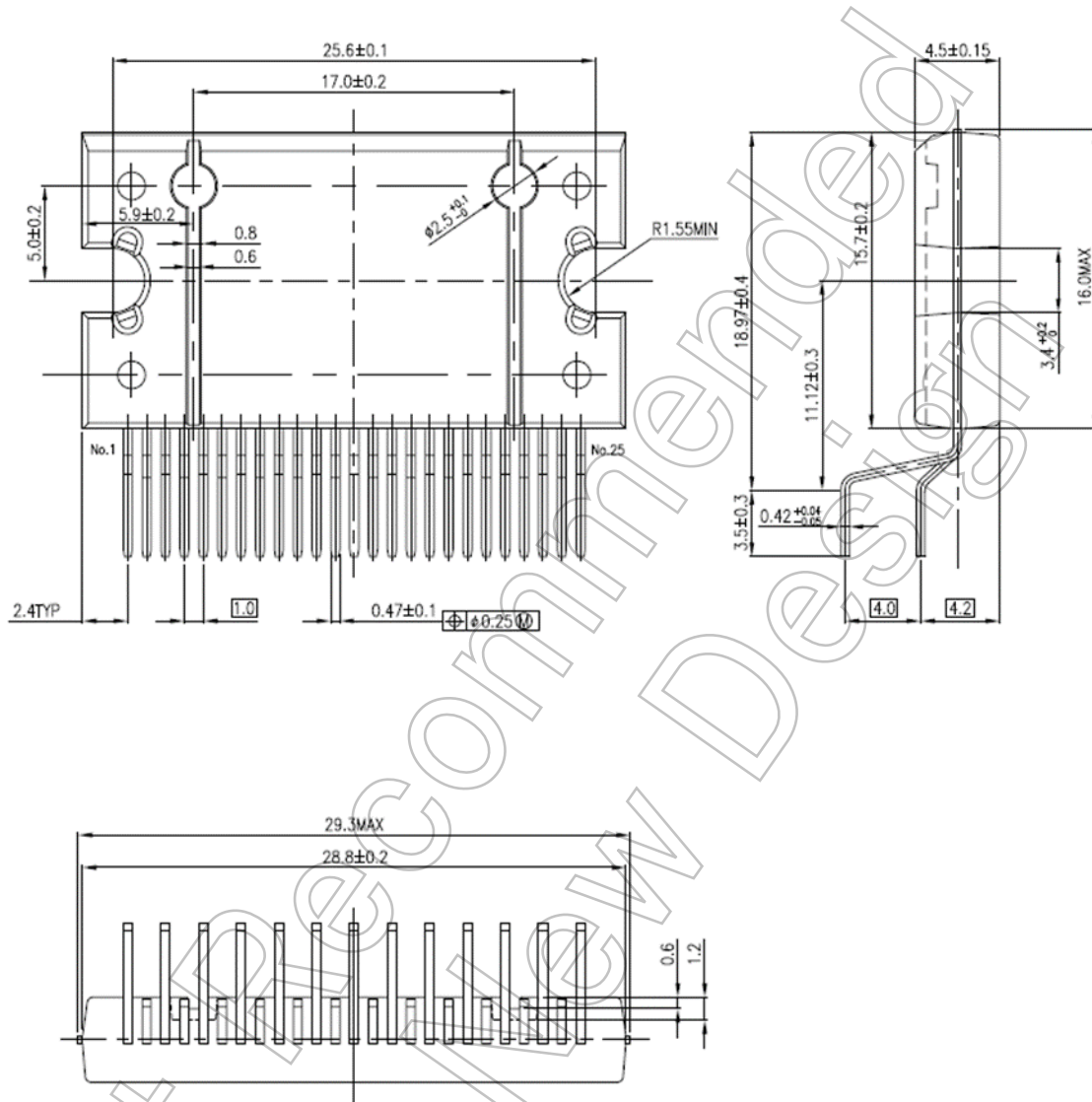

Weight: 7.7 g (typ.)

Notes on Contents

1. Block Diagrams

Some of the functional blocks, circuits, or constants in the block diagram may be omitted or simplified for explanatory purposes.

2. Equivalent Circuits

The equivalent circuit diagrams may be simplified or some parts of them may be omitted for explanatory purposes.

3. Timing Charts

Timing charts may be simplified for explanatory purposes.

4. Application Circuits

The application circuits shown in this document are provided for reference purposes only. Thorough evaluation is required, especially at the mass production design stage.

Toshiba does not grant any license to any industrial property rights by providing these examples of application circuits.

5. Test Circuits

Components in the test circuits are used only to obtain and confirm the device characteristics. These components and circuits are not guaranteed to prevent malfunction or failure from occurring in the application equipment.

IC Usage Considerations

Notes on handling of ICs

- [1] The absolute maximum ratings of a semiconductor device are a set of ratings that must not be exceeded, even for a moment. Do not exceed any of these ratings.
Exceeding the rating(s) may cause the device breakdown, damage or deterioration, and may result injury by explosion or combustion.
- [2] Use an appropriate power supply fuse to ensure that a large current does not continuously flow in case of over current and/or IC failure. The IC will fully break down when used under conditions that exceed its absolute maximum ratings, when the wiring is routed improperly or when an abnormal pulse noise occurs from the wiring or load, causing a large current to continuously flow and the breakdown can lead smoke or ignition. To minimize the effects of the flow of a large current in case of breakdown, appropriate settings, such as fuse capacity, fusing time and insertion circuit location, are required.
- [3] If your design includes an inductive load such as a motor coil, incorporate a protection circuit into the design to prevent device malfunction or breakdown caused by the current resulting from the inrush current at power ON or the negative current resulting from the back electromotive force at power OFF. IC breakdown may cause injury, smoke or ignition.
Use a stable power supply with ICs with built-in protection functions. If the power supply is unstable, the protection function may not operate, causing IC breakdown. IC breakdown may cause injury, smoke or ignition.
- [4] Do not insert devices in the wrong orientation or incorrectly.
Make sure that the positive and negative terminals of power supplies are connected properly.
Otherwise, the current or power consumption may exceed the absolute maximum rating, and exceeding the rating(s) may cause the device breakdown, damage or deterioration, and may result injury by explosion or combustion.
In addition, do not use any device that is applied the current with inserting in the wrong orientation or incorrectly even just one time.

Points to remember on handling of ICs**(1) Over current Protection Circuit**

Over current protection circuits (referred to as current limiter circuits) do not necessarily protect ICs under all circumstances. If the Over current protection circuits operate against the over current, clear the over current status immediately.

Depending on the method of use and usage conditions, such as exceeding absolute maximum ratings can cause the over current protection circuit to not operate properly or IC breakdown before operation. In addition, depending on the method of use and usage conditions, if over current continues to flow for a long time after operation, the IC may generate heat resulting in breakdown.

(2) Thermal Shutdown Circuit

Thermal shutdown circuits do not necessarily protect ICs under all circumstances. If the thermal shutdown circuits operate against the over temperature, clear the heat generation status immediately.

Depending on the method of use and usage conditions, such as exceeding absolute maximum ratings can cause the thermal shutdown circuit to not operate properly or IC breakdown before operation.

(3) Heat Radiation Design

In using an IC with large current flow such as power amp, regulator or driver, please design the device so that heat is appropriately radiated, not to exceed the specified junction temperature (T_J) at any time and condition. These ICs generate heat even during normal use. An inadequate IC heat radiation design can lead to decrease in IC life, deterioration of IC characteristics or IC breakdown. In addition, please design the device taking into consideration the effect of IC heat radiation with peripheral components.

(4) Back-EMF

When a motor rotates in the reverse direction, stops or slows down abruptly, a current flow back to the motor's power supply due to the effect of back-EMF. If the current sink capability of the power supply is small, the device's motor power supply and output pins might be exposed to conditions beyond maximum ratings. To avoid this problem, take the effect of back-EMF into consideration in system design.

Not Recommended for New Design

RESTRICTIONS ON PRODUCT USE

- Toshiba Corporation, and its subsidiaries and affiliates (collectively "TOSHIBA"), reserve the right to make changes to the information in this document, and related hardware, software and systems (collectively "Product") without notice.
- This document and any information herein may not be reproduced without prior written permission from TOSHIBA. Even with TOSHIBA's written permission, reproduction is permissible only if reproduction is without alteration/omission.
- Though TOSHIBA works continually to improve Product's quality and reliability, Product can malfunction or fail. Customers are responsible for complying with safety standards and for providing adequate designs and safeguards for their hardware, software and systems which minimize risk and avoid situations in which a malfunction or failure of Product could cause loss of human life, bodily injury or damage to property, including data loss or corruption. Before customers use the Product, create designs including the Product, or incorporate the Product into their own applications, customers must also refer to and comply with (a) the latest versions of all relevant TOSHIBA information, including without limitation, this document, the specifications, the data sheets and application notes for Product and the precautions and conditions set forth in the "TOSHIBA Semiconductor Reliability Handbook" and (b) the instructions for the application with which the Product will be used with or for. Customers are solely responsible for all aspects of their own product design or applications, including but not limited to (a) determining the appropriateness of the use of this Product in such design or applications; (b) evaluating and determining the applicability of any information contained in this document, or in charts, diagrams, programs, algorithms, sample application circuits, or any other referenced documents; and (c) validating all operating parameters for such designs and applications. **TOSHIBA ASSUMES NO LIABILITY FOR CUSTOMERS' PRODUCT DESIGN OR APPLICATIONS.**
- **PRODUCT IS NEITHER INTENDED NOR WARRANTED FOR USE IN EQUIPMENTS OR SYSTEMS THAT REQUIRE EXTRAORDINARILY HIGH LEVELS OF QUALITY AND/OR RELIABILITY, AND/OR A MALFUNCTION OR FAILURE OF WHICH MAY CAUSE LOSS OF HUMAN LIFE, BODILY INJURY, SERIOUS PROPERTY DAMAGE AND/OR SERIOUS PUBLIC IMPACT ("UNINTENDED USE").** Except for specific applications as expressly stated in this document, Unintended Use includes, without limitation, equipment used in nuclear facilities, equipment used in the aerospace industry, medical equipment, equipment used for automobiles, trains, ships and other transportation, traffic signaling equipment, equipment used to control combustions or explosions, safety devices, elevators and escalators, devices related to electric power, and equipment used in finance-related fields. **IF YOU USE PRODUCT FOR UNINTENDED USE, TOSHIBA ASSUMES NO LIABILITY FOR PRODUCT.** For details, please contact your TOSHIBA sales representative.
- Do not disassemble, analyze, reverse-engineer, alter, modify, translate or copy Product, whether in whole or in part.
- Product shall not be used for or incorporated into any products or systems whose manufacture, use, or sale is prohibited under any applicable laws or regulations.
- The information contained herein is presented only as guidance for Product use. No responsibility is assumed by TOSHIBA for any infringement of patents or any other intellectual property rights of third parties that may result from the use of Product. No license to any intellectual property right is granted by this document, whether express or implied, by estoppel or otherwise.
- **ABSENT A WRITTEN SIGNED AGREEMENT, EXCEPT AS PROVIDED IN THE RELEVANT TERMS AND CONDITIONS OF SALE FOR PRODUCT, AND TO THE MAXIMUM EXTENT ALLOWABLE BY LAW, TOSHIBA (1) ASSUMES NO LIABILITY WHATSOEVER, INCLUDING WITHOUT LIMITATION, INDIRECT, CONSEQUENTIAL, SPECIAL, OR INCIDENTAL DAMAGES OR LOSS, INCLUDING WITHOUT LIMITATION, LOSS OF PROFITS, LOSS OF OPPORTUNITIES, BUSINESS INTERRUPTION AND LOSS OF DATA, AND (2) DISCLAIMS ANY AND ALL EXPRESS OR IMPLIED WARRANTIES AND CONDITIONS RELATED TO SALE, USE OF PRODUCT, OR INFORMATION, INCLUDING WARRANTIES OR CONDITIONS OF MERCHANTABILITY, FITNESS FOR A PARTICULAR PURPOSE, ACCURACY OF INFORMATION, OR NONINFRINGEMENT.**
- Do not use or otherwise make available Product or related software or technology for any military purposes, including without limitation, for the design, development, use, stockpiling or manufacturing of nuclear, chemical, or biological weapons or missile technology products (mass destruction weapons). Product and related software and technology may be controlled under the applicable export laws and regulations including, without limitation, the Japanese Foreign Exchange and Foreign Trade Law and the U.S. Export Administration Regulations. Export and re-export of Product or related software or technology are strictly prohibited except in compliance with all applicable export laws and regulations.
- Please contact your TOSHIBA sales representative for details as to environmental matters such as the RoHS compatibility of Product. Please use Product in compliance with all applicable laws and regulations that regulate the inclusion or use of controlled substances, including without limitation, the EU RoHS Directive. **TOSHIBA ASSUMES NO LIABILITY FOR DAMAGES OR LOSSES OCCURRING AS A RESULT OF NONCOMPLIANCE WITH APPLICABLE LAWS AND REGULATIONS.**

Looking for pricing, stock, or lifecycle information?

Click below to explore more details on WIN SOURCE:

- [View TB6549HQ\(O\) on WIN SOURCE](#)
- [Toshiba Semiconductor and Storage Information](#)

Optimize Your Supply Chain with WIN SOURCE Solutions

- ✓ Global Sourcing Solution
- ✓ Obsolete Management
- ✓ Cost Control Management
- ✓ Shortage Management
- ✓ Alternative Solution
- ✓ Excess Inventory Management