



ON Semiconductor®

FAN3216 / FAN3217 Dual 2-A, High-Speed, Low-Side Gate Drivers

Features

- Industry-Standard Pinouts
- 4.5-V to 18-V Operating Range
- 3-A Peak Sink/Source at $V_{DD}=12\text{ V}$
- 2.4-A Sink / 1.6-A Source at $V_{OUT}=6\text{ V}$
- Inverting Configuration (FAN3216) and Non-Inverting Configuration (FAN3217)
- Internal Resistors Turn Driver Off If No Inputs
- 12-ns / 9-ns Typical Rise/Fall Times (1 nF Load)
- 20-ns Typical Propagation Delay Time Matched within 1 ns to the Other Channel
- TTL Input Thresholds
- MillerDrive™ Technology
- Double Current Capability by Paralleling Channels
- Standard SOIC-8 Package
- Rated from -40°C to $+125^{\circ}\text{C}$ Ambient
- Automotive Qualified to AEC-Q100 (F085 Versions)

Applications

- Switch-Mode Power Supplies
- High-Efficiency MOSFET Switching
- Synchronous Rectifier Circuits
- DC-to-DC Converters
- Motor Control
- Automotive-Qualified Systems (F085 Versions)

Description

The FAN3216 and FAN3217 dual 2 A gate drivers are designed to drive N-channel enhancement-mode MOSFETs in low-side switching applications by providing high peak current pulses during the short switching intervals. They are both available with TTL input thresholds. Internal circuitry provides an under-voltage lockout function by holding the output LOW until the supply voltage is within the operating range. In addition, the drivers feature matched internal propagation delays between A and B channels for applications requiring dual gate drives with critical timing, such as synchronous rectifiers. This also enables connecting two drivers in parallel to effectively double the current capability driving a single MOSFET.

The FAN3216/17 drivers incorporate MillerDrive™ architecture for the final output stage. This bipolar-MOSFET combination provides high current during the Miller plateau stage of the MOSFET turn-on / turn-off process to minimize switching loss, while providing rail-to-rail voltage swing and reverse current capability.

The FAN3216 offers two inverting drivers and the FAN3217 offers two non-inverting drivers. Both are offered in a standard 8-pin SOIC package.

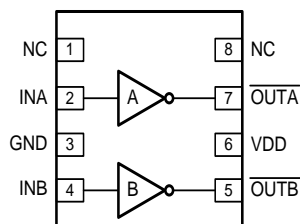

Figure 1. FAN3216 Pin Configuration

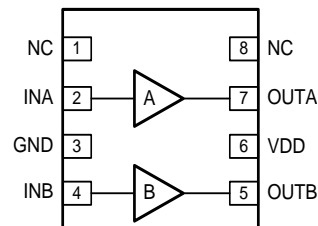

Figure 2. FAN3217 Pin Configuration

Ordering Information

Part Number	Logic	Input Threshold	Package	Packing Method	Quantity per Reel
FAN3216TMX	Dual Inverting Channels	TTL	SOIC-8	Tape & Reel	2,500
FAN3216TMX_F085 ⁽¹⁾	Dual Inverting Channels	TTL	SOIC-8	Tape & Reel	2,500
FAN3217TMX	Dual Non-Inverting Channels	TTL	SOIC-8	Tape & Reel	2,500
FAN3217TMX_F085 ⁽¹⁾	Dual Non-Inverting Channels	TTL	SOIC-8	Tape & Reel	2,500

Note:

1. Qualified to AEC-Q100

Package Outlines

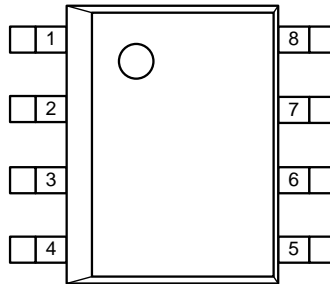

Figure 3. SOIC-8 (Top View)

Thermal Characteristics⁽²⁾

Package	Θ_{JL} ⁽³⁾	Θ_{JT} ⁽⁴⁾	Θ_{JA} ⁽⁵⁾	Ψ_{JB} ⁽⁶⁾	Ψ_{JT} ⁽⁷⁾	Unit
8-Pin Small Outline Integrated Circuit (SOIC)	40	31	89	43	3.0	°C/W

Notes:

2. Estimates derived from thermal simulation; actual values depend on the application.
3. Θ_{JL} (Θ_{JL}): Thermal resistance between the semiconductor junction and the bottom surface of all the leads (including any thermal pad) that are typically soldered to a PCB.
4. Θ_{JT} (Θ_{JT}): Thermal resistance between the semiconductor junction and the top surface of the package, assuming it is held at a uniform temperature by a top-side heatsink.
5. Θ_{JA} (Θ_{JA}): Thermal resistance between junction and ambient, dependent on the PCB design, heat sinking, and airflow. The value given is for natural convection with no heatsink using a 2S2P board, as specified in JEDEC standards JESD51-2, JESD51-5, and JESD51-7, as appropriate.
6. Ψ_{JB} (Ψ_{JB}): Thermal characterization parameter providing correlation between semiconductor junction temperature and an application circuit board reference point for the thermal environment defined in Note 5. For the SOIC-8 package, the board reference is defined as the pcb copper adjacent to pin 6.
7. Ψ_{JT} (Ψ_{JT}): Thermal characterization parameter providing correlation between the semiconductor junction temperature and the center of the top of the package for the thermal environment defined in Note 5.

Pin Configurations

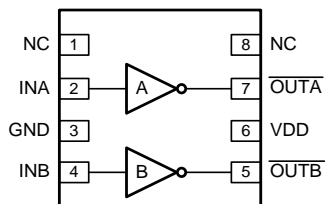

Figure 4. FAN3216

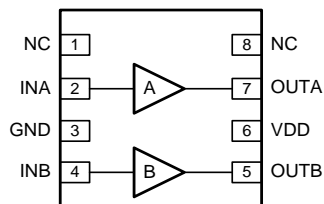

Figure 5. FAN3217

Pin Definitions

Pin	Name	Pin Description
1	NC	No Connect. This pin can be grounded or left floating.
2	INA	Input to Channel A.
3	GND	Ground. Common ground reference for input and output circuits.
4	INB	Input to Channel B.
5 (FAN3216)	OUTB	Gate Drive Output B (inverted from the input): Held LOW unless required input is present and V _{DD} is above UVLO threshold.
5 (FAN3217)	OUTB	Gate Drive Output B: Held LOW unless required input(s) are present and V _{DD} is above UVLO threshold.
6	VDD	Supply Voltage. Provides power to the IC.
7 (FAN3216)	OUTA	Gate Drive Output A (inverted from the input): Held LOW unless required input is present and V _{DD} is above UVLO threshold.
7 (FAN3217)	OUTA	Gate Drive Output A: Held LOW unless required input(s) are present and V _{DD} is above UVLO threshold.
8	NC	No Connect. This pin can be grounded or left floating.

Output Logic

FAN3216 (x=A or B)	
IN _x	OUT _x
0	1
1 ⁽⁸⁾	0

FAN3217 (x=A or B)	
IN _x	OUT _x
0 ⁽⁸⁾	0
1	1

Note:

8. Default input signal if no external connection is made.

Block Diagrams

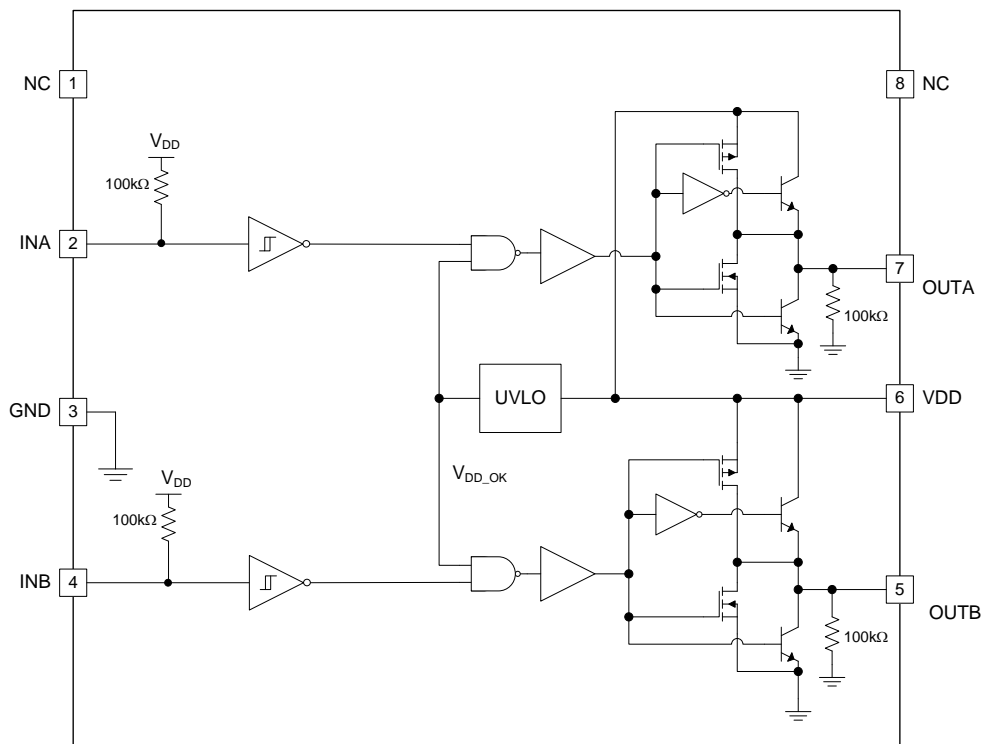

Figure 6. FAN3216 Block Diagram

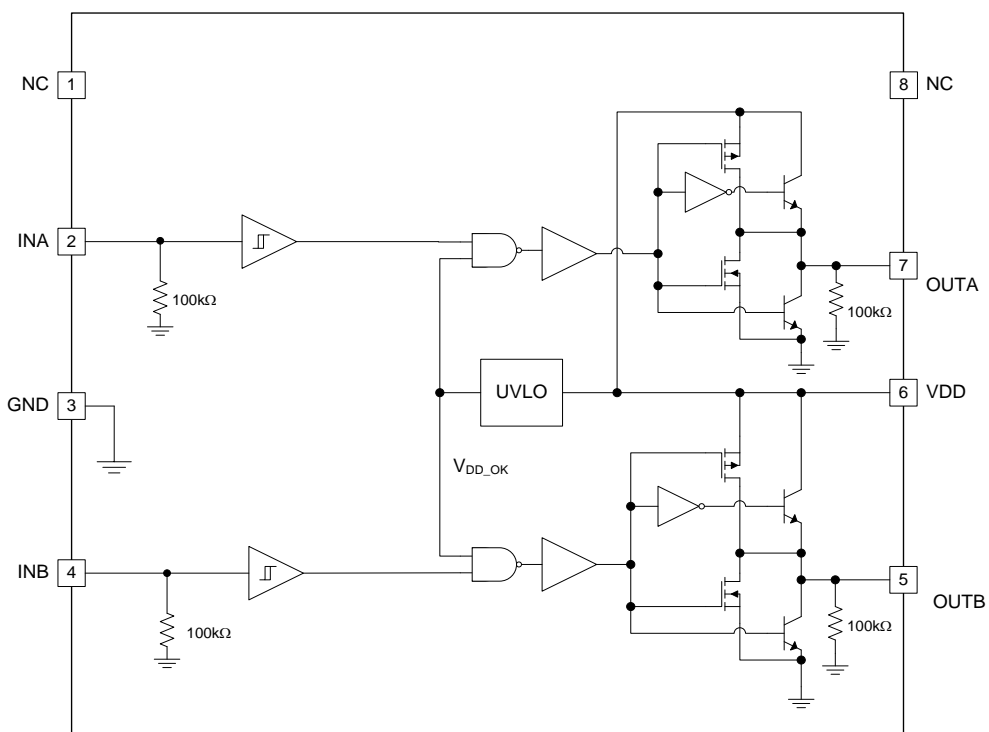

Figure 7. FAN3217 Block Diagram

Absolute Maximum Ratings

Stresses exceeding the absolute maximum ratings may damage the device. The device may not function or be operable above the recommended operating conditions and stressing the parts to these levels is not recommended. In addition, extended exposure to stresses above the recommended operating conditions may affect device reliability. The absolute maximum ratings are stress ratings only.

Symbol	Parameter	Min.	Max.	Unit
V _{DD}	VDD to PGND	-0.3	20.0	V
V _{IN}	INA and INB to GND	GND - 0.3	V _{DD} + 0.3	V
V _{OUT}	OUTA and OUTB to GND	GND - 0.3	V _{DD} + 0.3	V
T _L	Lead Soldering Temperature (10 Seconds)		+260	°C
T _J	Junction Temperature	-55	+150	°C
T _{STG}	Storage Temperature	-65	+150	°C

Recommended Operating Conditions

The Recommended Operating Conditions table defines the conditions for actual device operation. Recommended operating conditions are specified to ensure optimal performance to the datasheet specifications. ON Semiconductor does not recommend exceeding them or designing to Absolute Maximum Ratings.

Symbol	Parameter	Min.	Max.	Unit
V _{DD}	Supply Voltage Range	4.5	18.0	V
V _{IN}	Input Voltage INA and INB	0	V _{DD}	V
T _A	Operating Ambient Temperature	-40	+125	°C

Electrical Characteristics

Unless otherwise noted, $V_{DD}=12\text{ V}$, $T_J=-40^\circ\text{C}$ to $+125^\circ\text{C}$. Currents are defined as positive into the device and negative out of the device.

Symbol	Parameter	Conditions	Min.	Typ.	Max.	Unit
Supply						
V_{DD}	Operating Range		4.5		18.0	V
I_{DD}	Supply Current, Inputs Not Connected			0.75	1.20	mA
V_{ON}	Turn-On Voltage	$I_{NA}=V_{DD}$, $I_{NB}=0\text{ V}$	3.45	3.90	4.35	V
V_{OFF}	Turn-Off Voltage	$I_{NA}=V_{DD}$, $I_{NB}=0\text{ V}$	3.25	3.70	4.15	V
FAN3216TMX_F085, FAN3217TMX_F085 (Automotive-Qualified Versions)						
V_{ON}	Turn-On Voltage ⁽¹¹⁾	$I_{NA}=V_{DD}$, $I_{NB}=0\text{ V}$	3.40	3.90	4.60	V
V_{OFF}	Turn-Off Voltage ⁽¹¹⁾	$I_{NA}=V_{DD}$, $I_{NB}=0\text{ V}$	3.20	3.70	4.30	V
Inputs						
V_{IL_T}	INx Logic Low Threshold		0.8	1.2		V
V_{IH_T}	INx Logic High Threshold			1.6	2.0	V
V_{HYS_T}	TTL Logic Hysteresis Voltage		0.2	0.4	0.8	V
FAN3216TMX, FAN3217TMX						
I_{IN+}	Non-inverting Input Current	IN from 0 to V_{DD}	-1.0		175	μA
I_{IN-}	Inverting Input Current	IN from 0 to V_{DD}	-175.0		1.0	μA
FAN3216TMX_F085, FAN3217TMX_F085 (Automotive-Qualified Versions)						
I_{IN_T}	Non-inverting Input Current ⁽¹¹⁾	$I_{IN}=0\text{ V}$	-1.5		1.5	μA
I_{IN_T}	Non-inverting Input Current ⁽¹¹⁾	$I_{IN}=V_{DD}$	90	120	175.0	μA
I_{IN_T}	Inverting Input Current ⁽¹¹⁾	$I_{IN}=0\text{ V}$	-175.0	-120	-90	μA
I_{IN_T}	Inverting Input Current ⁽¹¹⁾	$I_{IN}=V_{DD}$	-1.5		1.5	μA
Outputs						
I_{SINK}	OUT Current, Mid-Voltage, Sinking ⁽⁹⁾	OUTx at $V_{DD}/2$, $C_{LOAD}=0.22\text{ }\mu\text{F}$, $f=1\text{ kHz}$		2.4		A
I_{SOURCE}	OUT Current, Mid-Voltage, Sourcing ⁽⁹⁾	OUTx at $V_{DD}/2$, $C_{LOAD}=0.1\text{ }\mu\text{F}$, $f=1\text{ kHz}$		-1.6		A
I_{PK_SINK}	OUT Current, Peak, Sinking ⁽⁹⁾	$C_{LOAD}=0.1\text{ }\mu\text{F}$, $f=1\text{ kHz}$		3		A
I_{PK_SOURCE}	OUT Current, Peak, Sourcing ⁽⁹⁾	$C_{LOAD}=0.1\text{ }\mu\text{F}$, $f=1\text{ kHz}$		-3		A
t_{RISE}	Output Rise Time ⁽¹⁰⁾	$C_{LOAD}=1000\text{ pF}$		12	22	ns
t_{FALL}	Output Fall Time ⁽¹⁰⁾	$C_{LOAD}=1000\text{ pF}$		9	17	ns
t_{D1}, t_{D2}	Output Propagation Delay, TTL Inputs ⁽¹⁰⁾	$0 - 5 V_{IN}$, $1V/ns$ Slew Rate	10	19	34	ns
	Propagation Matching Between Channels	$I_{NA}=I_{NB}$, OUTA and OUTB at 50% Point		1	2	ns
I_{RVS}	Output Reverse Current Withstand ⁽⁹⁾			500		mA

Continued on the following page...

Electrical Characteristics (Continued)

Unless otherwise noted, $V_{DD}=12\text{ V}$, $T_J=-40^\circ\text{C}$ to $+125^\circ\text{C}$. Currents are defined as positive into the device and negative out of the device.

Symbol	Parameter	Conditions	Min.	Typ.	Max.	Unit
Outputs (continued)						
FAN3216TMX_F085, FAN3217TMX_F085 (Automotive-Qualified Versions)						
t_{D1}, t_{D2}	Output Propagation Delay, TTL Inputs ⁽¹¹⁾	$0 - 5 V_{IN}, 1\text{ V/ns}$ Slew Rate	4.5	19.0	34.0	ns
	Propagation Matching Between Channels ⁽¹¹⁾	$I_{NA}=I_{NB}, O_{UTA}$ and O_{UTB} at 50% Point		2	4	ns
V_{OH}	High Level Output Voltage ⁽¹¹⁾	$V_{OH}=V_{DD}-V_{OUT}, I_{OUT}=-1\text{ mA}$		15	35	mV
V_{OL}	Low Level Output Voltage ⁽¹¹⁾	$I_{OUT}=1\text{ mA}$		10	25	mV

Notes:

- 9. Not tested in production.
- 10. See *Timing Diagrams of Figure 8 and Figure 9.*
- 11. Apply to only F085 Version

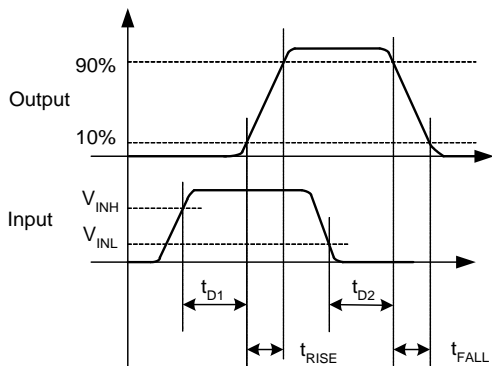

Figure 8. Non-Inverting Timing Diagram

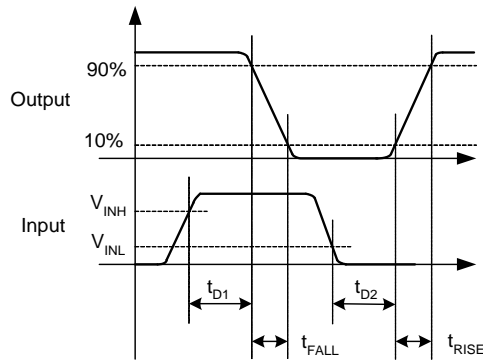

Figure 9. Inverting Timing Diagram

Typical Performance Characteristics

Typical characteristics are provided at $T_A=25^\circ\text{C}$ and $V_{DD}=12\text{V}$ unless otherwise noted.

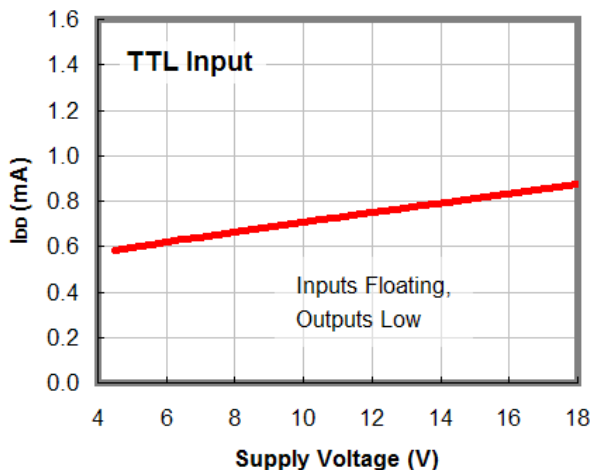

Figure 10. I_{DD} (Static) vs. Supply Voltage⁽¹²⁾

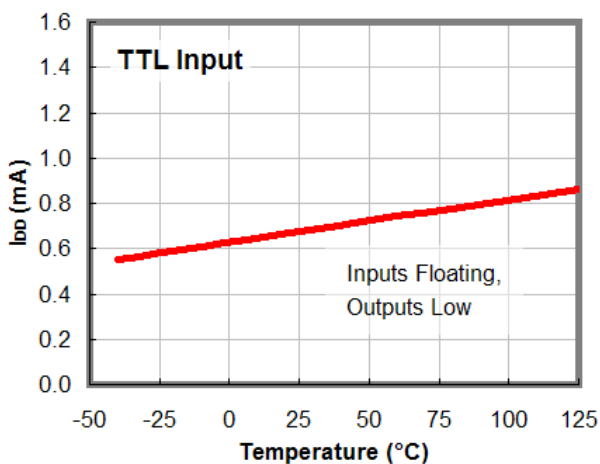

Figure 11. I_{DD} (Static) vs. Temperature⁽¹²⁾

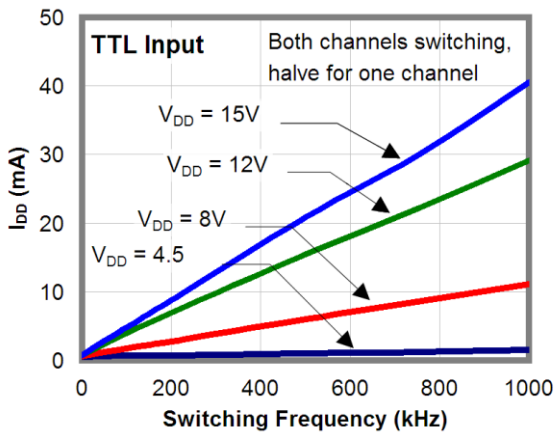

Figure 12. I_{DD} (No-Load) vs. Frequency

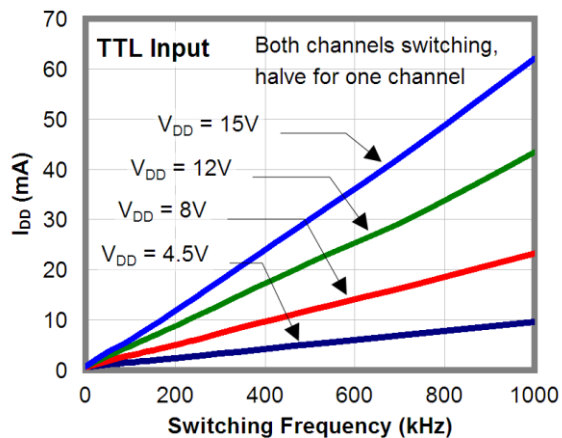

Figure 13. I_{DD} (1 nF Load) vs. Frequency

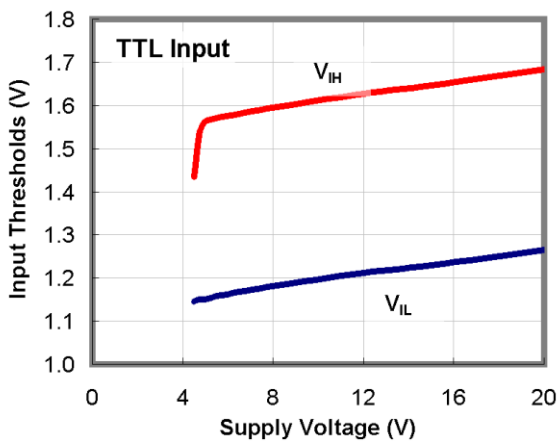

Figure 14. Input Thresholds vs. Supply Voltage

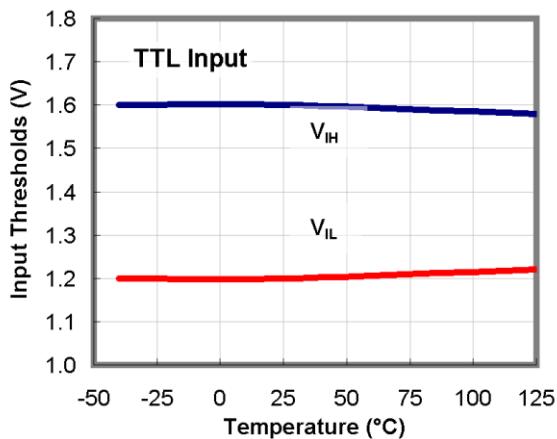

Figure 15. Input Thresholds vs. Temperature

Typical Performance Characteristics

Typical characteristics are provided at $T_A=25^\circ\text{C}$ and $V_{DD}=12\text{V}$ unless otherwise noted.

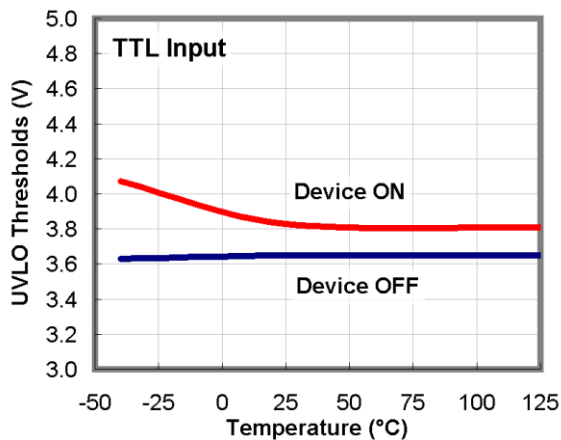

Figure 16. UVLO Threshold vs. Temperature

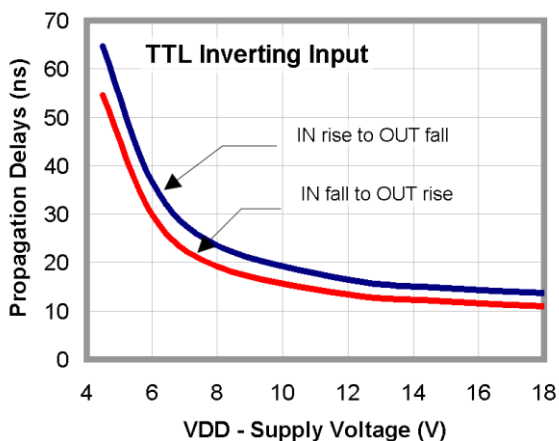

Figure 17. Propagation Delay vs. Supply Voltage

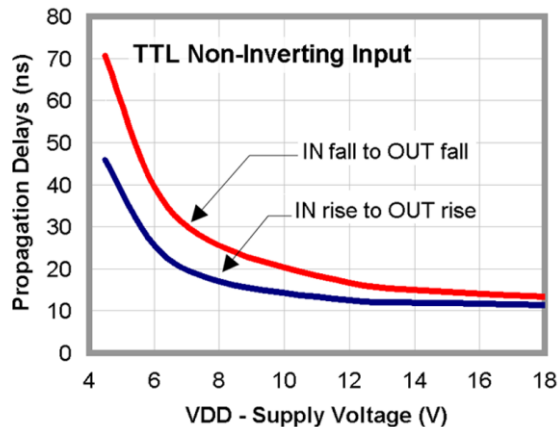

Figure 18. Propagation Delay vs. Supply Voltage

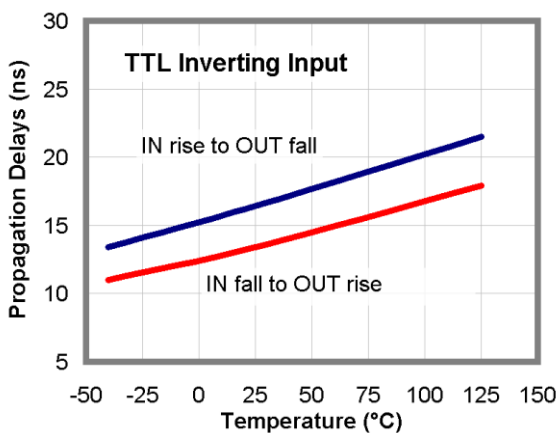

Figure 19. Propagation Delays vs. Temperature

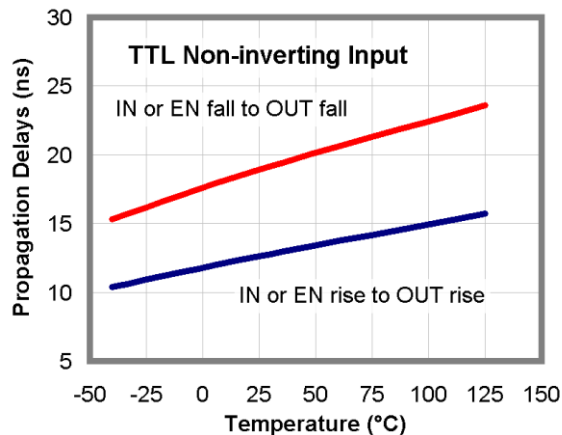

Figure 20. Propagation Delays vs. Temperature

Typical Performance Characteristics

Typical characteristics are provided at $T_A=25^\circ\text{C}$ and $V_{DD}=12\text{V}$ unless otherwise noted.

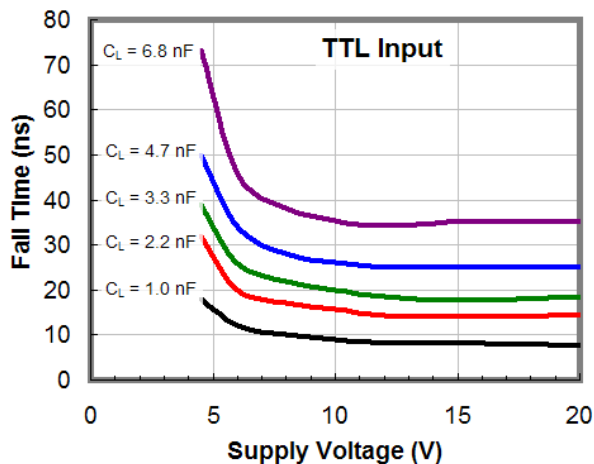

Figure 21. Fall Time vs. Supply Voltage

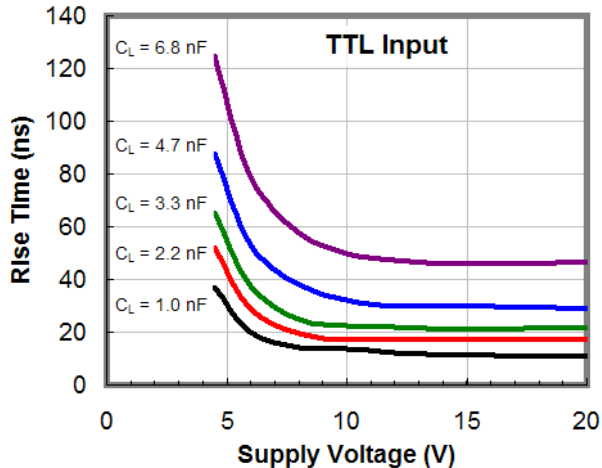

Figure 22. Rise Time vs. Supply Voltage

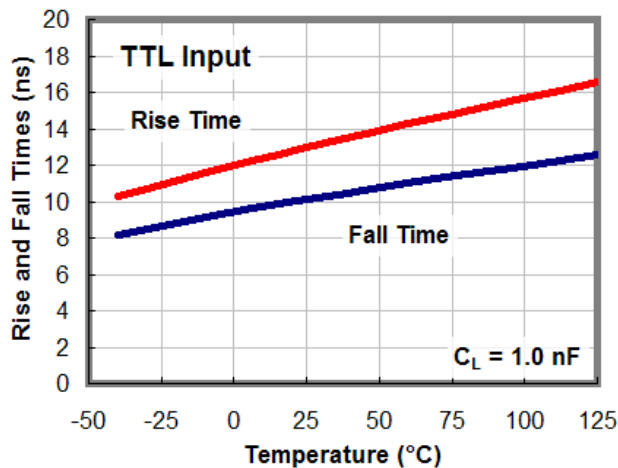

Figure 23. Rise and Fall Times vs. Temperature

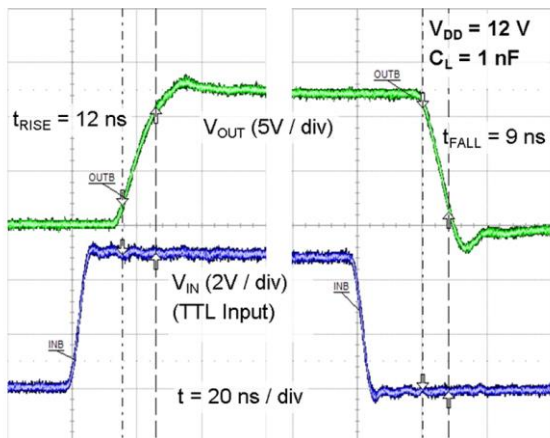

Figure 24. Rise/Fall Waveforms with 2.2 nF Load

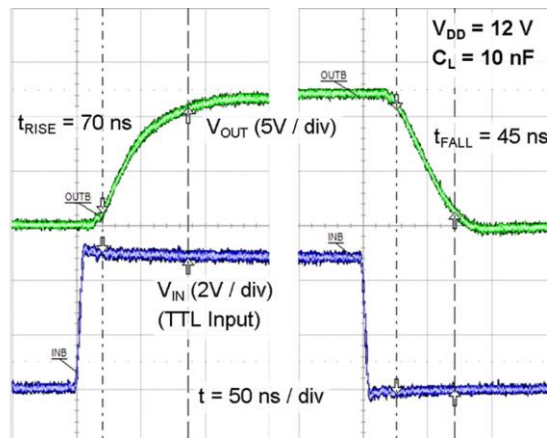

Figure 25. Rise/Fall Waveforms with 10 nF Load

Typical Performance Characteristics

Typical characteristics are provided at $T_A=25^\circ\text{C}$ and $V_{DD}=12\text{V}$ unless otherwise noted.

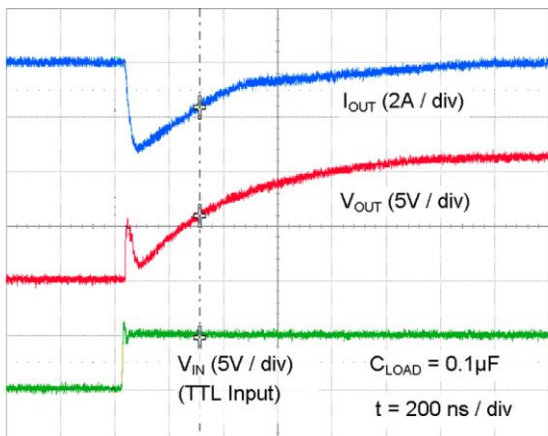

Figure 26. Quasi-Static Source Current with $V_{DD}=12\text{V}$ ⁽¹³⁾

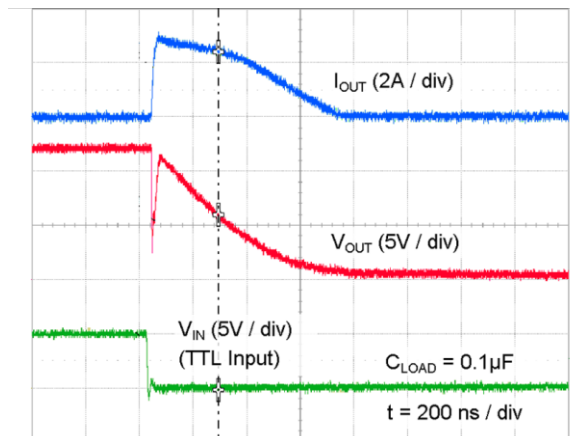

Figure 27. Quasi-Static Sink Current with $V_{DD}=12\text{V}$ ⁽¹³⁾

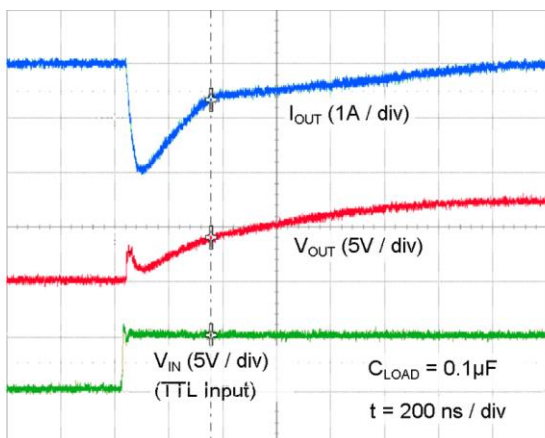

Figure 28. Quasi-Static Source Current with $V_{DD}=8\text{V}$ ⁽¹³⁾

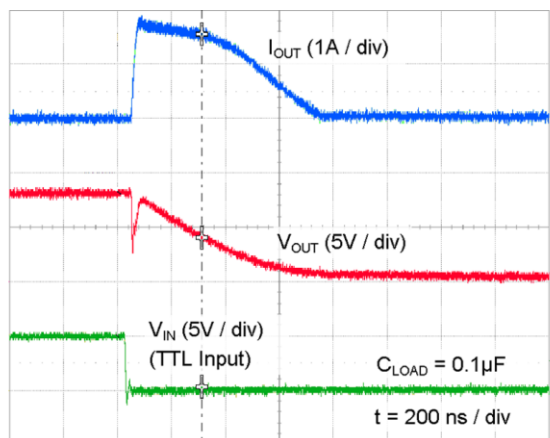

Figure 29. Quasi-Static Sink Current with $V_{DD}=8\text{V}$ ⁽¹³⁾

Notes:

12. For any inverting inputs pulled low, non-inverting inputs pulled high, or outputs driven high; static I_{DD} increases by the current flowing through the corresponding pull-up/down resistor shown in Figure 6 and Figure 7.
13. The initial spike in each current waveform is a measurement artifact caused by the stray inductance of the current-measurement loop.

Test Circuit

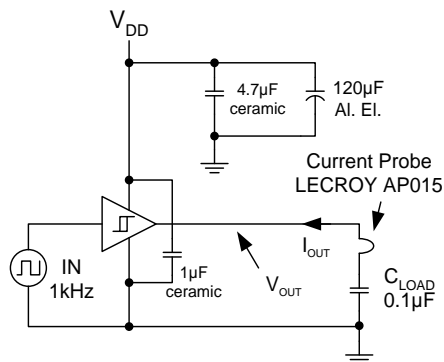

Figure 30. Quasi-Static I_{OUT} / V_{OUT} Test Circuit

Applications Information

Input Thresholds

The FAN3216 and the FAN3217 drivers consist of two identical channels that may be used independently at rated current or connected in parallel to double the individual current capacity.

The input thresholds meet industry-standard TTL-logic thresholds independent of the V_{DD} voltage, and there is a hysteresis voltage of approximately 0.4 V. These levels permit the inputs to be driven from a range of input logic signal levels for which a voltage over 2 V is considered logic HIGH. The driving signal for the TTL inputs should have fast rising and falling edges with a slew rate of 6 V/ μ s or faster, so a rise time from 0 to 3.3 V should be 550 ns or less. With reduced slew rate, circuit noise could cause the driver input voltage to exceed the hysteresis voltage and retrigger the driver input, causing erratic operation.

Static Supply Current

In the I_{DD} (static) typical performance characteristics shown in Figure 10 and Figure 11, each curve is produced with both inputs floating and both outputs LOW to indicate the lowest static I_{DD} current. For other states, additional current flows through the 100k Ω resistors on the inputs and outputs shown in the block diagram of each part (see Figure 6 and Figure 7). In these cases, the actual static I_{DD} current is the value obtained from the curves plus this additional current.

MillerDrive™ Gate Drive Technology

FAN3216 and FAN3217 gate drivers incorporate the MillerDrive™ architecture shown in Figure 31. For the output stage, a combination of bipolar and MOS devices provide large currents over a wide range of supply voltage and temperature variations. The bipolar devices carry the bulk of the current as OUT swings between 1/3 to 2/3 V_{DD} and the MOS devices pull the output to the HIGH or LOW rail.

The purpose of the MillerDrive™ architecture is to speed up switching by providing high current during the Miller plateau region when the gate-drain capacitance of the MOSFET is being charged or discharged as part of the turn-on / turn-off process.

For applications with zero voltage switching during the MOSFET turn-on or turn-off interval, the driver supplies high peak current for fast switching even though the Miller plateau is not present. This situation often occurs in synchronous rectifier applications because the body diode is generally conducting before the MOSFET is switched ON.

The output pin slew rate is determined by V_{DD} voltage and the load on the output. It is not user adjustable, but a series resistor can be added if a slower rise or fall time at the MOSFET gate is needed.

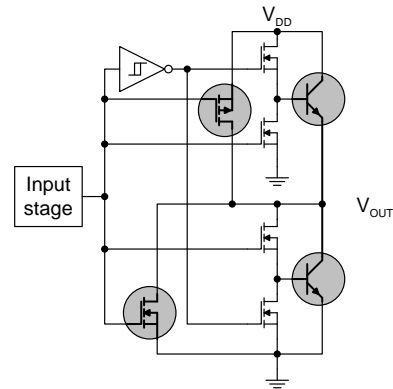

Figure 31. MillerDrive™ Output Architecture

Under-Voltage Lockout

The FAN321x startup logic is optimized to drive ground-referenced N-channel MOSFETs with an under-voltage lockout (UVLO) function to ensure that the IC starts up in an orderly fashion. When V_{DD} is rising, yet below the 3.9 V operational level, this circuit holds the output LOW, regardless of the status of the input pins. After the part is active, the supply voltage must drop 0.2 V before the part shuts down. This hysteresis helps prevent chatter when low V_{DD} supply voltages have noise from the power switching. This configuration is not suitable for driving high-side P-channel MOSFETs because the low output voltage of the driver would turn the P-channel MOSFET on with V_{DD} below 3.9 V.

V_{DD} Bypass Capacitor Guidelines

To enable this IC to turn a device ON quickly, a local high-frequency bypass capacitor, C_{BYP} , with low ESR and ESL should be connected between the VDD and GND pins with minimal trace length. This capacitor is in addition to bulk electrolytic capacitance of 10 μ F to 47 μ F commonly found on driver and controller bias circuits.

A typical criterion for choosing the value of C_{BYP} is to keep the ripple voltage on the V_{DD} supply to $\leq 5\%$. This is often achieved with a value ≥ 20 times the equivalent load capacitance C_{EQV} , defined here as Q_{GATE}/V_{DD} . Ceramic capacitors of 0.1 μ F to 1 μ F or larger are common choices, as are dielectrics, such as X5R and X7R, with good temperature characteristics and high pulse current capability.

If circuit noise affects normal operation, the value of C_{BYP} may be increased, to 50-100 times the C_{EQV} , or C_{BYP} may be split into two capacitors. One should be a larger value, based on equivalent load capacitance, and the other a smaller value, such as 1-10 nF mounted closest to the VDD and GND pins to carry the higher-frequency components of the current pulses. The bypass capacitor must provide the pulsed current from both of the driver channels and, if the drivers are switching simultaneously, the combined peak current sourced from the C_{BYP} would be twice as large as when a single channel is switching.

Layout and Connection Guidelines

The FAN3216 and FAN3217 gate drivers incorporate fast-reacting input circuits, short propagation delays, and powerful output stages capable of delivering current peaks over 2 A to facilitate voltage transition times from under 10 ns to over 150 ns. The following layout and connection guidelines are strongly recommended:

- Keep high-current output and power ground paths separate from logic input signals and signal ground paths. This is especially critical for TTL-level logic thresholds at driver input pins.
- Keep the driver as close to the load as possible to minimize the length of high-current traces. This reduces the series inductance to improve high-speed switching, while reducing the loop area that can radiate EMI to the driver inputs and surrounding circuitry.
- If the inputs to a channel are not externally connected, the internal 100 k Ω resistors indicated on block diagrams command a low output. In noisy environments, it may be necessary to tie inputs of an unused channel to VDD or GND using short traces to prevent noise from causing spurious output switching.
- Many high-speed power circuits can be susceptible to noise injected from their own output or other external sources, possibly causing output re-triggering. These effects can be obvious if the circuit is tested in breadboard or non-optimal circuit layouts with long input or output leads. For best results, make connections to all pins as short and direct as possible.
- FAN3216 and FAN3217 are pin-compatible with many other industry-standard drivers.
- The turn-on and turn-off current paths should be minimized, as discussed in the following section.

Figure 32 shows the pulsed gate drive current path when the gate driver is supplying gate charge to turn the MOSFET on. The current is supplied from the local bypass capacitor, C_{BYP} , and flows through the driver to the MOSFET gate and to ground. To reach the high peak currents possible, the resistance and inductance in the path should be minimized. The localized C_{BYP} acts to contain the high peak current pulses within this driver-MOSFET circuit, preventing them from disturbing the sensitive analog circuitry in the PWM controller.

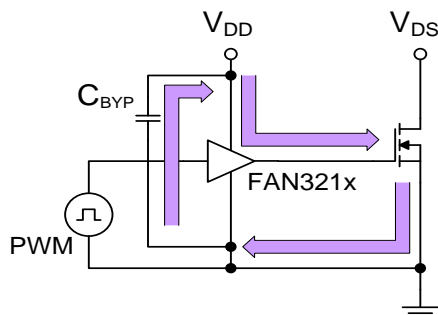

Figure 32. Current Path for MOSFET Turn-On

Figure 33 shows the current path when the gate driver turns the MOSFET OFF. Ideally, the driver shunts the current directly to the source of the MOSFET in a small circuit loop. For fast turn-off times, the resistance and inductance in this path should be minimized.

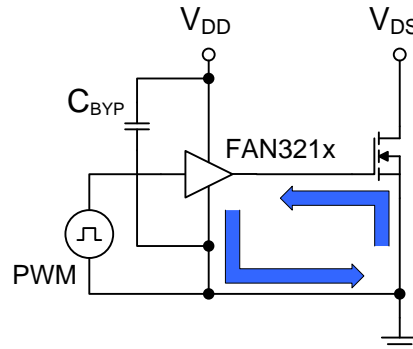

Figure 33. Current Path for MOSFET Turn-Off

Operational Waveforms

At power-up, the driver output remains LOW until the V_{DD} voltage reaches the turn-on threshold. The magnitude of the OUT pulses rises with V_{DD} until steady-state V_{DD} is reached. The non-inverting operation illustrated in Figure 34 shows that the output remains LOW until the UVLO threshold is reached, then the output is in-phase with the input.

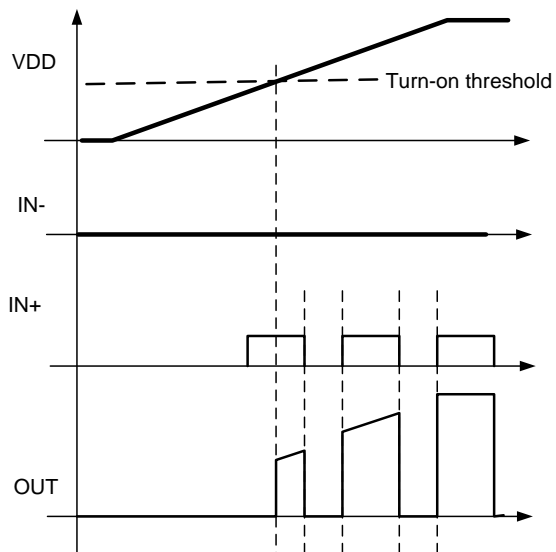

Figure 34. Non-Inverting Startup Waveforms

The inverting configuration of startup waveforms are shown in Figure 35. With $IN+$ tied to V_{DD} and the input signal applied to $IN-$, the OUT pulses are inverted with respect to the input. At power-up, the inverted output remains LOW until the V_{DD} voltage reaches the turn-on threshold, then it follows the input with inverted phase.

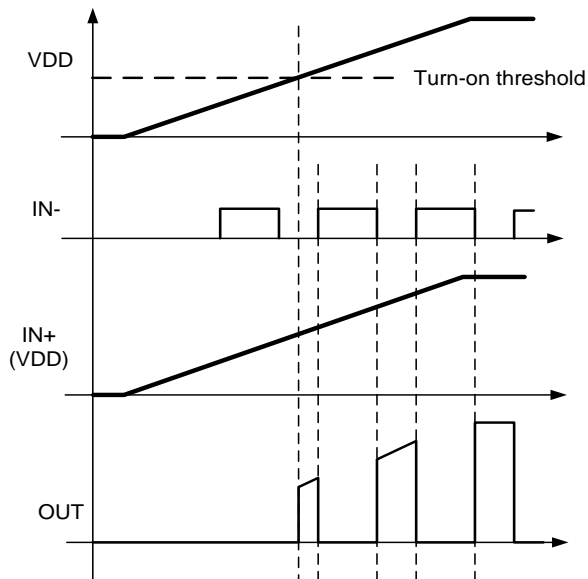

Figure 35. Inverting Startup Waveforms

Thermal Guidelines

Gate drivers used to switch MOSFETs and IGBTs at high frequencies can dissipate significant amounts of power. It is important to determine the driver power dissipation and the resulting junction temperature in the application to ensure that the part is operating within acceptable temperature limits.

The total power dissipation in a gate driver is the sum of two components, P_{GATE} and $P_{DYNAMIC}$:

$$P_{TOTAL} = P_{GATE} + P_{DYNAMIC} \quad (1)$$

Gate Driving Loss: The most significant power loss results from supplying gate current (charge per unit time) to switch the load MOSFET on and off at the switching frequency. The power dissipation that results from driving a MOSFET at a specified gate-source voltage, V_{GS} , with gate charge, Q_G , at switching frequency, f_{SW} , is determined by:

$$P_{GATE} = Q_G \cdot V_{GS} \cdot f_{SW} \cdot n \quad (2)$$

where n is the number of driver channels in use (1 or 2).

Dynamic Pre-Drive / Shoot-through Current: A power loss resulting from internal current consumption under dynamic operating conditions, including pin pull-up / pull-down resistors, can be obtained using the graphs in Typical Performance Characteristics to determine the current $I_{DYNAMIC}$ drawn from V_{DD} under actual operating conditions:

$$P_{DYNAMIC} = I_{DYNAMIC} \cdot V_{DD} \cdot n \quad (3)$$

Once the power dissipated in the driver is determined, the driver junction rise with respect to circuit board can be evaluated using the following thermal equation, assuming Ψ_{JB} was determined for a similar thermal design (heat sinking and air flow):

$$T_J = P_{TOTAL} \cdot \Psi_{JB} + T_B \quad (4)$$

where:

T_J = driver junction temperature;

Ψ_{JB} = (psi) thermal characterization parameter relating temperature rise to total power dissipation; and

T_B = board temperature in location as defined in the Thermal Characteristics table.

In the forward converter with synchronous rectifier shown in the typical application diagrams, the FDMS8660S is a reasonable MOSFET selection. The gate charge for each SR MOSFET would be 60 nC with $V_{GS} = V_{DD} = 7V$. At a switching frequency of 500 kHz, the total power dissipation is:

$$P_{GATE} = 60 \text{ nC} \cdot 7 \text{ V} \cdot 500 \text{ kHz} \cdot 2 = 0.42 \text{ W} \quad (5)$$

$$P_{DYNAMIC} = 3 \text{ mA} \cdot 7 \text{ V} \cdot 2 = 0.042 \text{ W} \quad (6)$$

$$P_{TOTAL} = 0.46 \text{ W} \quad (7)$$

The SOIC-8 has a junction-to-board thermal characterization parameter of $\Psi_{JB} = 43^\circ\text{C/W}$. In a system application, the localized temperature around the device is a function of the layout and construction of the PCB along with airflow across the surfaces. To ensure reliable operation, the maximum junction temperature of the device must be prevented from exceeding the maximum rating of 150°C ; with 80% derating, T_J would be limited to 120°C . Rearranging Equation 4 determines the board temperature required to maintain the junction temperature below 120°C :

$$T_B = T_J - P_{TOTAL} \cdot \Psi_{JB} \quad (8)$$

$$T_B = 120^\circ\text{C} - 0.46 \text{ W} \cdot 43^\circ\text{C/W} = 100^\circ\text{C} \quad (9)$$

Typical Application Diagrams

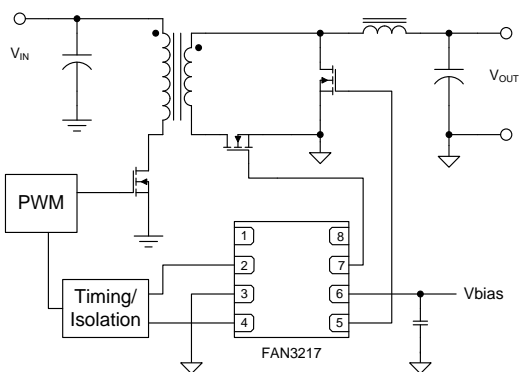

Figure 36. Forward Converter with Synchronous Rectification

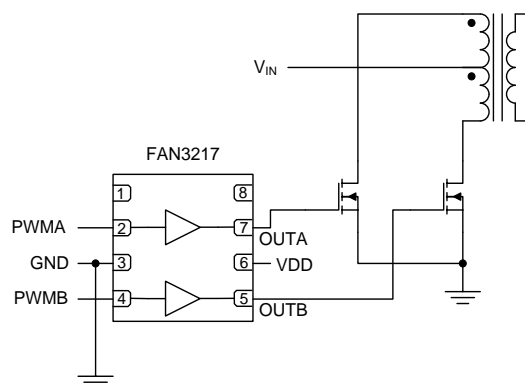

Figure 37. Primary-Side Dual Driver in a Push-Pull Converter

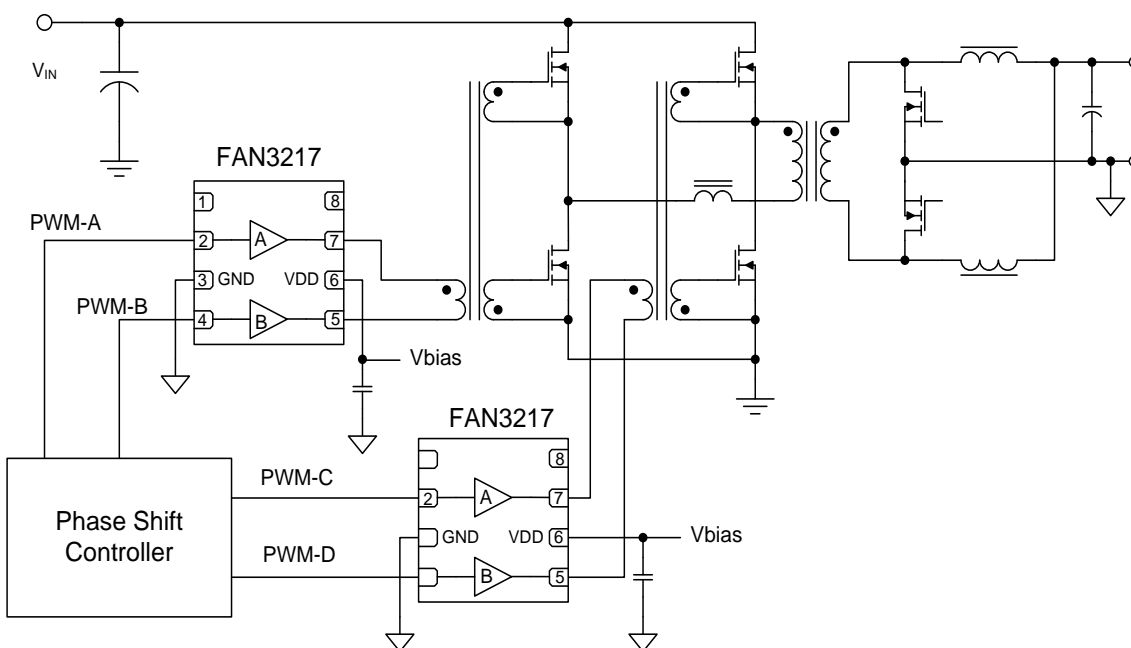

Figure 38. Phase-Shifted Full-Bridge with Two Gate Drive Transformers (Simplified)

Table 1. Related Products

Type	Part Number	Gate Drive ⁽¹⁴⁾ (Sink/Src)	Input Threshold	Logic	Package
Single 1 A	FAN3111C	+1.1 A / -0.9 A	CMOS	Single Channel of Dual-Input/Single-Output	SOT23-5, MLP6
Single 1 A	FAN3111E	+1.1 A / -0.9 A	External ⁽¹⁵⁾	Single Non-Inverting Channel with External Reference	SOT23-5, MLP6
Single 2 A	FAN3100C	+2.5 A / -1.8 A	CMOS	Single Channel of Two-Input/One-Output	SOT23-5, MLP6
Single 2 A	FAN3100T	+2.5 A / -1.8 A	TTL	Single Channel of Two-Input/One-Output	SOT23-5, MLP6
Single 2 A	FAN3180	+2.4 A / -1.6 A	TTL	Single Non-Inverting Channel + 3.3-V LDO	SOT23-5
Dual 2 A	FAN3216T	+2.4 A / -1.6 A	TTL	Dual Inverting Channels	SOIC8
Dual 2 A	FAN3217T	+2.4 A / -1.6 A	TTL	Dual Non-Inverting Channels	SOIC8
Dual 2 A	FAN3226C	+2.4 A / -1.6 A	CMOS	Dual Inverting Channels+ Dual Enable	SOIC8, MLP8
Dual 2 A	FAN3226T	+2.4 A / -1.6 A	TTL	Dual Inverting Channels+ Dual Enable	SOIC8, MLP8
Dual 2 A	FAN3227C	+2.4 A / -1.6 A	CMOS	Dual Non-Inverting Channels+ Dual Enable	SOIC8, MLP8
Dual 2 A	FAN3227T	+2.4 A / -1.6 A	TTL	Dual Non-Inverting Channels+ Dual Enable	SOIC8, MLP8
Dual 2 A	FAN3228C	+2.4 A / -1.6 A	CMOS	Dual Channels of Two-Input/One-Output, Pin Config.1	SOIC8, MLP8
Dual 2 A	FAN3228T	+2.4 A / -1.6 A	TTL	Dual Channels of Two-Input/One-Output, Pin Config.1	SOIC8, MLP8
Dual 2 A	FAN3229C	+2.4 A / -1.6 A	CMOS	Dual Channels of Two-Input/One-Output, Pin Config.2	SOIC8, MLP8
Dual 2 A	FAN3229T	+2.4 A / -1.6 A	TTL	Dual Channels of Two-Input/One-Output, Pin Config.2	SOIC8, MLP8
Dual 2 A	FAN3268T	+2.4 A / -1.6 A	TTL	20 V Non-Inverting Channel (NMOS) and Inverting Channel (PMOS) + Dual Enables	SOIC8
Dual 2 A	FAN3278T	+2.4 A / -1.6 A	TTL	30 V Non-Inverting Channel (NMOS) and Inverting Channel (PMOS) + Dual Enables	SOIC8
Dual 4 A	FAN3213T	+2.5 A / -1.8 A	TTL	Dual Inverting Channels	SOIC8
Dual 4 A	FAN3214T	+2.5 A / -1.8 A	TTL	Dual Non-Inverting Channels	SOIC8
Dual 4 A	FAN3223C	+4.3 A / -2.8 A	CMOS	Dual Inverting Channels+ Dual Enable	SOIC8, MLP8
Dual 4 A	FAN3223T	+4.3 A / -2.8 A	TTL	Dual Inverting Channels+ Dual Enable	SOIC8, MLP8
Dual 4 A	FAN3224C	+4.3 A / -2.8 A	CMOS	Dual Non-Inverting Channels+ Dual Enable	SOIC8, MLP8
Dual 4 A	FAN3224T	+4.3 A / -2.8 A	TTL	Dual Non-Inverting Channels+ Dual Enable	SOIC8, MLP8
Dual 4 A	FAN3225C	+4.3 A / -2.8 A	CMOS	Dual Channels of Two-Input/One-Output	SOIC8, MLP8
Dual 4 A	FAN3225T	+4.3 A / -2.8 A	TTL	Dual Channels of Two-Input/One-Output	SOIC8, MLP8
Single 9 A	FAN3121C	+9.7 A / -7.1 A	CMOS	Single Inverting Channel + Enable	SOIC8, MLP8
Single 9 A	FAN3121T	+9.7 A / -7.1 A	TTL	Single Inverting Channel + Enable	SOIC8, MLP8
Single 9 A	FAN3122T	+9.7 A / -7.1 A	CMOS	Single Non-Inverting Channel + Enable	SOIC8, MLP8
Single 9 A	FAN3122C	+9.7 A / -7.1 A	TTL	Single Non-Inverting Channel + Enable	SOIC8, MLP8
Dual 12 A	FAN3240	+12.0 A	TTL	Dual-Coil Relay Driver, Timing Config. 0	SOIC8
Dual 12 A	FAN3241	+12.0 A	TTL	Dual-Coil Relay Driver, Timing Config. 1	SOIC8

Notes:14. Typical currents with OUTx at 6 V and V_{DD}=12 V.

15. Thresholds proportional to an externally supplied reference voltage.

Physical Dimensions

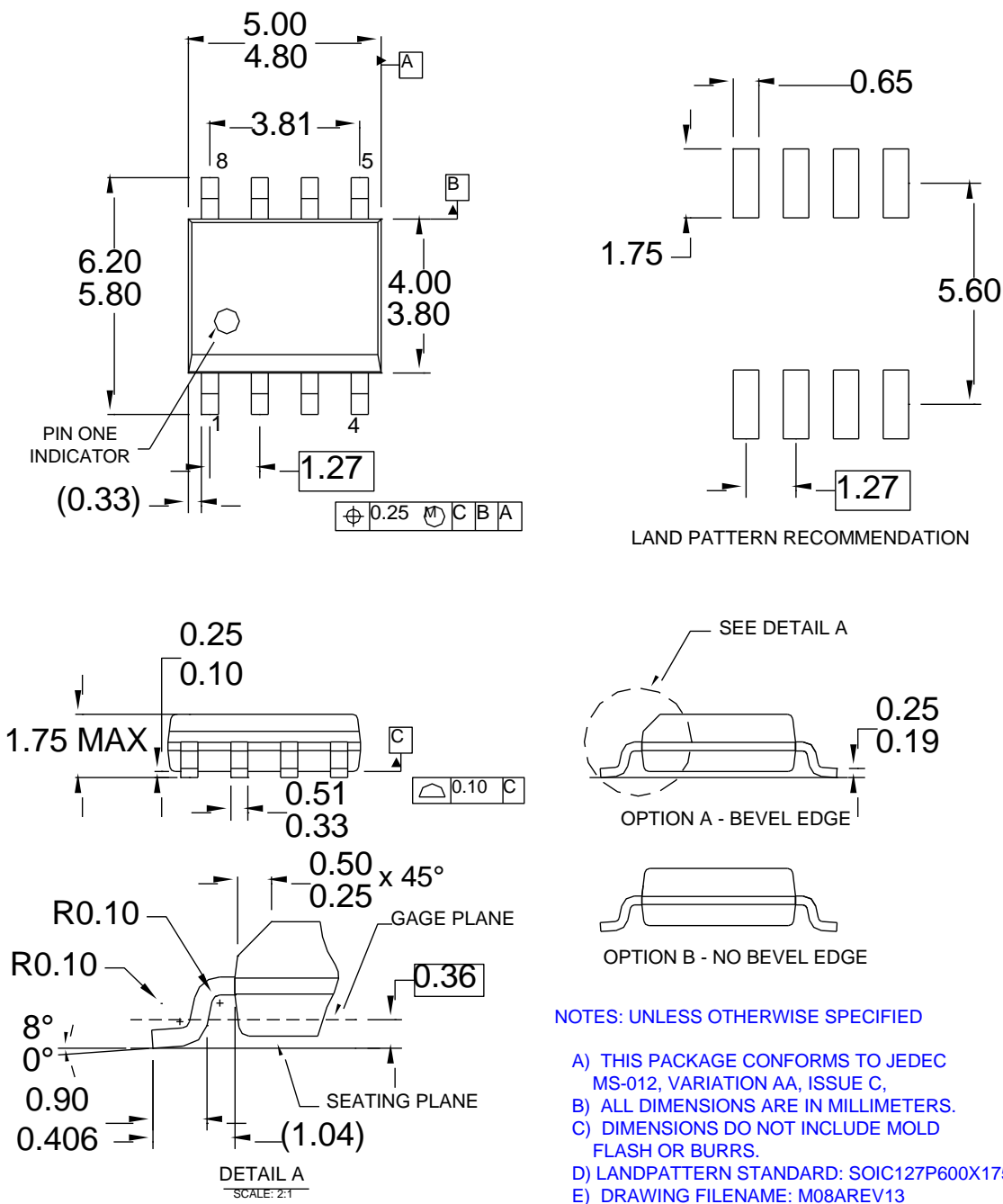

Figure 39. 8-Lead Small Outline Integrated Circuit (SOIC)

Package drawings are provided as a service to customers considering ON Semiconductor components. Drawings may change in any manner without notice. Please note the revision and/or date on the drawing and contact ON Semiconductor representative to verify or obtain the most recent revision. Package specifications do not expand the terms of ON Semiconductor's worldwide terms and conditions, specifically the warranty therein, which covers ON Semiconductor products.

ON Semiconductor and the ON Semiconductor logo are trademarks of Semiconductor Components Industries, LLC dba ON Semiconductor or its subsidiaries in the United States and/or other countries. ON Semiconductor owns the rights to a number of patents, trademarks, copyrights, trade secrets, and other intellectual property. A listing of ON Semiconductor's product/patent coverage may be accessed at www.onsemi.com/site/pdf/Patent-Marking.pdf. ON Semiconductor reserves the right to make changes without further notice to any products herein. ON Semiconductor makes no warranty, representation or guarantee regarding the suitability of its products for any particular purpose, nor does ON Semiconductor assume any liability arising out of the application or use of any product or circuit, and specifically disclaims any and all liability, including without limitation special, consequential or incidental damages. Buyer is responsible for its products and applications using ON Semiconductor products, including compliance with all laws, regulations and safety requirements or standards, regardless of any support or applications information provided by ON Semiconductor. "Typical" parameters which may be provided in ON Semiconductor data sheets and/or specifications can and do vary in different applications and actual performance may vary over time. All operating parameters, including "Typicals" must be validated for each customer application by customer's technical experts. ON Semiconductor does not convey any license under its patent rights nor the rights of others. ON Semiconductor products are not designed, intended, or authorized for use as a critical component in life support systems or any FDA Class 3 medical devices or medical devices with a same or similar classification in a foreign jurisdiction or any devices intended for implantation in the human body. Should Buyer purchase or use ON Semiconductor products for any such unintended or unauthorized application, Buyer shall indemnify and hold ON Semiconductor and its officers, employees, subsidiaries, affiliates, and distributors harmless against all claims, costs, damages, and expenses, and reasonable attorney fees arising out of, directly or indirectly, any claim of personal injury or death associated with such unintended or unauthorized use, even if such claim alleges that ON Semiconductor was negligent regarding the design or manufacture of the part. ON Semiconductor is an Equal Opportunity/Affirmative Action Employer. This literature is subject to all applicable copyright laws and is not for resale in any manner.

PUBLICATION ORDERING INFORMATION

LITERATURE FULFILLMENT:

Literature Distribution Center for ON Semiconductor
19521 E. 32nd Pkwy, Aurora, Colorado 80011 USA

Phone: 303-675-2175 or 800-344-3860 Toll Free USA/Canada

Fax: 303-675-2176 or 800-344-3867 Toll Free USA/Canada

Email: orderlit@onsemi.com

N. American Technical Support: 800-282-9855 Toll Free
USA/Canada.

Europe, Middle East and Africa Technical Support:
Phone: 421 33 790 2910

Japan Customer Focus Center
Phone: 81-3-5817-1050

ON Semiconductor Website: www.onsemi.com

Order Literature: <http://www.onsemi.com/orderlit>

For additional information, please contact your local
Sales Representative

Looking for pricing, stock, or lifecycle information?

Click below to explore more details on WIN SOURCE:

- ⊖ [View FAN3216TMX on WIN SOURCE](#)
- ⊖ [Fairchild/ON Semiconductor Information](#)

Optimize Your Supply Chain with WIN SOURCE Solutions

- ✓ Global Sourcing Solution
- ✓ Obsolete Management
- ✓ Cost Control Management
- ✓ Shortage Management
- ✓ Alternative Solution
- ✓ Excess Inventory Management