



**THE DATASHEET OF
DS2720BU+T&R**



FEATURES

- Rechargeable Lithium-Ion (Li+) Safety Circuit
 - Overvoltage Protection
 - Overcurrent/Short-Circuit Protection
 - Undervoltage Protection
 - Overtemperature Protection
- Controls High-Side N-Channel Power MOSFETs Driven from 9V Charge Pump
- System Power Management and Control Feature Support
- Eight Bytes of Lockable EEPROM
- Dallas 1-Wire[®] Interface with Unique 64-Bit Device Address
- 8-Pin μ SOP Package
- Low Power Consumption:
 - Active Current: 12.5 μ A typ
 - Sleep Current: 1.5 μ A typ

PIN CONFIGURATION

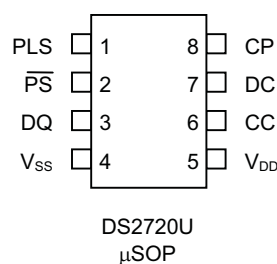

PIN DESCRIPTION

- PLS - Battery-Pack Positive Terminal Input
- \overline{PS} - Power-Switch Sense Input
- DQ - Data Input/Output
- V_{SS} - Device Ground
- V_{DD} - Power-Supply Input
- CP - Reservoir Capacitor
- CC - Charge Control Output
- DC - Discharge Control Output

DESCRIPTION

The DS2720 single-cell rechargeable Li+ protection IC provides electronic safety functions required for rechargeable Li+ applications including protecting the battery during charge, protection of the circuit from damage during periods of excess current flow and maximization of battery life by limiting the level of cell depletion. Protection is facilitated by electronically disconnecting the charge and discharge conduction path with switching devices such as low-cost N-channel power MOSFETs.

Since the DS2720 provides high-side drive to external N-channel protection MOSFETs from a 9V charge pump, superior on-resistance performance results compared to common low-side protector circuits using the same FETs. The FET on-resistance actually decreases as the battery discharges.

Adding to the uniqueness of the DS2720 is the ability of the system to control the FETs from either the data interface or a dedicated input thereby eliminating the power-switch control redundancy of rechargeable Li+ battery systems.

Through its 1-Wire interface, the DS2720 gives the host system read/write access to status and control registers, instrumentation registers, and general-purpose data storage. Each device has a factory-programmed 64-bit net address that allows it to be individually addressed by the host system.

Two types of user-memory are provided on the DS2720 for battery information storage: EEPROM and lockable EEPROM. EEPROM memory saves important battery data in true nonvolatile (NV) memory that is unaffected by severe battery depletion, accidental shorts, or ESD events. Lockable EEPROM becomes ROM when locked to provide additional security for unchanging battery data.

ORDERING INFORMATION

PART	DESCRIPTION
DS2720AU+	DS2720+ in 8-Lead μ SOP in Bulk with $V_{OVA} = 4.275V$
DS2720AU+T&R	DS2720+ in 8-Lead μ SOP in Tape-and-Reel with $V_{OVA} = 4.275V$
DS2720BU+	DS2720+ in 8-Lead μ SOP in Bulk with $V_{OVb} = 4.35V$
DS2720BU+T&R	DS2720+ in 8-Lead μ SOP in Tape-and-Reel with $V_{OVb} = 4.35V$
DS2720CU+	DS2720+ in 8-Lead μ SOP in Bulk with $V_{OVc} = 4.30V$
DS2720CU+T&R	DS2720+ in 8-Lead μ SOP in Tape-and-Reel with $V_{OVc} = 4.30V$
DS2720AU	DS2720 in 8-Lead μ SOP in Bulk with $V_{OVA} = 4.275V$
DS2720AU/T&R	DS2720 in 8-Lead μ SOP in Tape-and-Reel with $V_{OVA} = 4.275V$
DS2720BU	DS2720 in 8-Lead μ SOP in Bulk with $V_{OVb} = 4.35V$
DS2720BU/T&R	DS2720 in 8-Lead μ SOP in Tape-and-Reel with $V_{OVb} = 4.35V$
DS2720CU	DS2720 in 8-Lead μ SOP in Bulk with $V_{OVc} = 4.30V$
DS2720CU/T&R	DS2720 in 8-Lead μ SOP in Tape-and-Reel with $V_{OVc} = 4.30V$

+ Denotes lead-free package.

Figure 1. BLOCK DIAGRAM

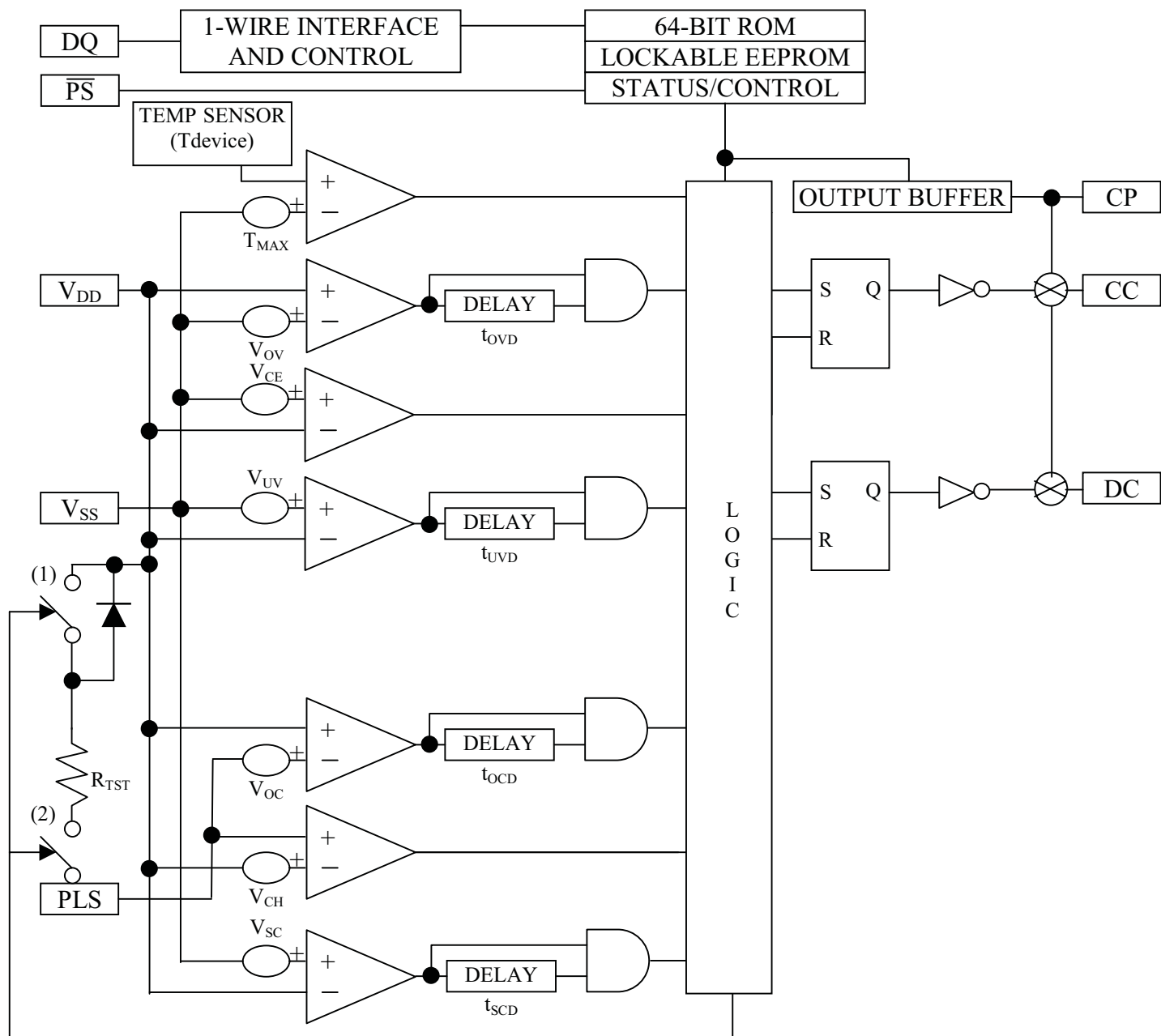

- 1) Normally open, closed to enable test current, I_{TST}
- 2) Normally open, closed to enable test current, I_{TST} , and recovery charge
(See *Rechargeable Li+ Protection Circuitry* section for more information.)

Table 1. DETAILED PIN DESCRIPTION

SYMBOL	DESCRIPTION
PLS	Battery-Pack Positive Terminal Input. The device monitors the state of the battery pack's positive terminal through this pin in order to detect events such as the attachment of a charger or the removal of a short circuit. Connect PLS to the pack positive terminal through a 100Ω resistor.
$\overline{\text{PS}}$	Power-Switch Sense Input. The device wakes up from sleep mode when it senses the closure of a switch to V_{SS} on this pin. $\overline{\text{PS}}$ has a high-impedance internal pullup.
DQ	Data Input/Out. 1-Wire data line. Open-drain output driver. Connect this pin to the DATA terminal of the battery pack. DQ has an internal 0.5μA pull-down.
V_{SS}	Device Ground. Connect directly to the negative terminal of the battery cell.
V_{DD}	Power Supply Input. Connect V_{DD} to the positive terminal of the battery cell through a decoupling network.
CP	Charge Pump Output. The internal charge pump regulates CP to 9V which supplies the ON state drive to the protection FETs. Connect a 0.1μF reservoir capacitor from CP to V_{SS} .
CC	Charge Protection Control Output. Controls an external N-channel high-side charge protection FET.
DC	Discharge Protection Control Output. Controls an external N-channel high-side discharge protection FET.

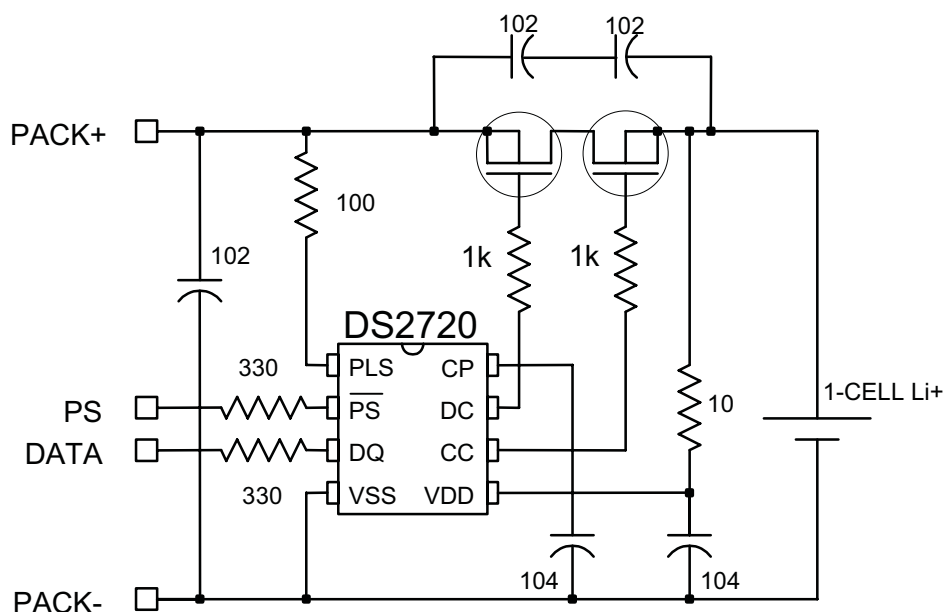
Figure 2. APPLICATION EXAMPLE

POWER MODES

The DS2720 has two power modes: active and sleep. While in active mode, the DS2720 continuously performs safety monitoring. In sleep mode, the DS2720 ceases monitoring activities and drives both the charge and discharge protection FETs to an “off state”. Upon returning to the active mode from the sleep mode, DS2720 resumes safety monitoring and conditionally turns on the protection FETs.

Table 2. POWER MODE TRANSITION CONDITIONS

Active → Sleep	Sleep → Active ⁽¹⁾
$V_{DD} < V_{UV}$	\overline{PS} pulled to V_{SS} or $V_{PLS} > V_{DD} + V_{CH}$

(1) DS2720 does not transition to Active Mode if $V_{DD} < V_{SC}$.

RECHARGEABLE Li+ PROTECTION CIRCUITRY

During active mode, the DS2720 constantly monitors cell voltage and voltage drop across the FETs to protect the battery from overcharge (overvoltage), overdischarge (undervoltage), and excessive discharge currents (overcurrent, short circuit). Conditions and DS2720 responses are described in the sections below and summarized in Table 3 and Figure 3.

Table 3. PROTECTION CONDITIONS AND DS2720 RESPONSES

CONDITION NAME	ACTIVATION			RELEASE THRESHOLD
	THRESHOLD	DELAY	RESPONSE	
Overvoltage	$V_{DD} > V_{OV}$	$t_{OVD}^{(1)}$	CC = V_{OLCC}	$V_{DD} < V_{CE}$ or $V_{DD} - V_{PLS} > V_{OC}$
Undervoltage	$V_{SC} < V_{DD} < V_{UV}$	t_{UVD}	CC = V_{OLCC} DC = V_{OLDC}	$V_{PLS} > V_{DD} + V_{CH}$ and $V_{DD} > V_{UV}$ (charger connected)
Recovery Charge	$V_{DD} < V_{SC}$ or (while in active mode) $V_{DD} < V_{CE}$		R_{TST} enabled ⁽²⁾	$V_{DD} \geq V_{CE}$
Overcurrent	$V_{DD} - V_{PLS} > V_{OC}$	t_{OCD}	CC = V_{OLCC} DC = V_{OLCC}	$V_{PLS} > V_{DD} - V_{OC}^{(3)}$
Short Circuit	$V_{DD} < V_{SC}$	t_{SCD}	CC = V_{OLCC} DC = V_{OLDC}	$V_{PLS} > V_{DD} - V_{OC}^{(3)}$
Overtemperature	$T_{device} > T_{MAX}$		CC = V_{OLCC} DC = V_{OLDC}	$T_{device} < T_{MAX}$

All voltages are with respect to V_{SS} .

(1) During transition from sleep to active, $t_{OVD} = 0$.

(2) Recovery charge current is limited by R_{TST} and forward voltage of blocking diode, which prevents discharging through R_{TST} when recovery charge enabled.

(3) With test current I_{TST} flowing from V_{DD} to PLS (pullup on PLS).

Overvoltage. If the cell voltage sensed at V_{DD} exceeds overvoltage threshold V_{OV} for a period longer than overvoltage delay t_{OVD} , the DS2720 shuts off the external charge FET and sets the OV flag in the protection register. Discharging remains enabled during overvoltage. The charge FET is re-enabled (unless another protection condition prevents it), when the cell voltage falls below charge enable threshold V_{CE} , or a discharge causes $V_{DD} - V_{PLS} > V_{OC}$.

Undervoltage. If the cell voltage sensed at V_{DD} drops below undervoltage threshold V_{UV} for a period longer than undervoltage delay t_{UVD} , the DS2720 shuts off the charge and discharge FETs, sets the UV flag in the protection register, and enters sleep mode. The DS2720 turns on both the charge and discharge FETs after the cell voltage rises above V_{UV} and a charger is present.

Short Circuit. If the cell voltage sensed at V_{DD} drops below depletion threshold V_{SC} for a period of t_{SCD} , the DS2720 shuts off the charge and discharge FETs and sets the DOC flag in the protection register. The current path through the charge and discharge FETs is not re-established until the voltage on PLS rises above $V_{DD} - V_{OC}$. The DS2720 provides a test current through internal resistor R_{TST} from V_{DD} to PLS to pull up PLS when V_{DD} rises above V_{SC} . The test current allows the DS2720 to detect the removal of the offending low-impedance load. Additionally, a recovery charge path through R_{TST} from PLS to V_{DD} is enabled.

Overcurrent. If the voltage across the protection FETs ($V_{DD} - V_{PLS}$) is greater than V_{OC} for a period longer than t_{OCD} , the DS2720 shuts off the external charge and discharge FETs and sets the DOC flag in the protection register. The current path is not re-established until the voltage on PLS rises above $V_{DD} - V_{OC}$. The DS2720 provides a test current through internal resistor R_{TST} from V_{DD} to PLS to detect the removal of the offending low-impedance load.

Overtemperature. If the device temperature exceeds T_{MAX} , the DS2720 immediately shuts off the external discharge and charge FETs. The FETs are not turned back on until the cell temperature drops below T_{MAX} AND the host resets the OT bit.

Figure 3. Li+ PROTECTION CIRCUITRY EXAMPLE WAVEFORMS

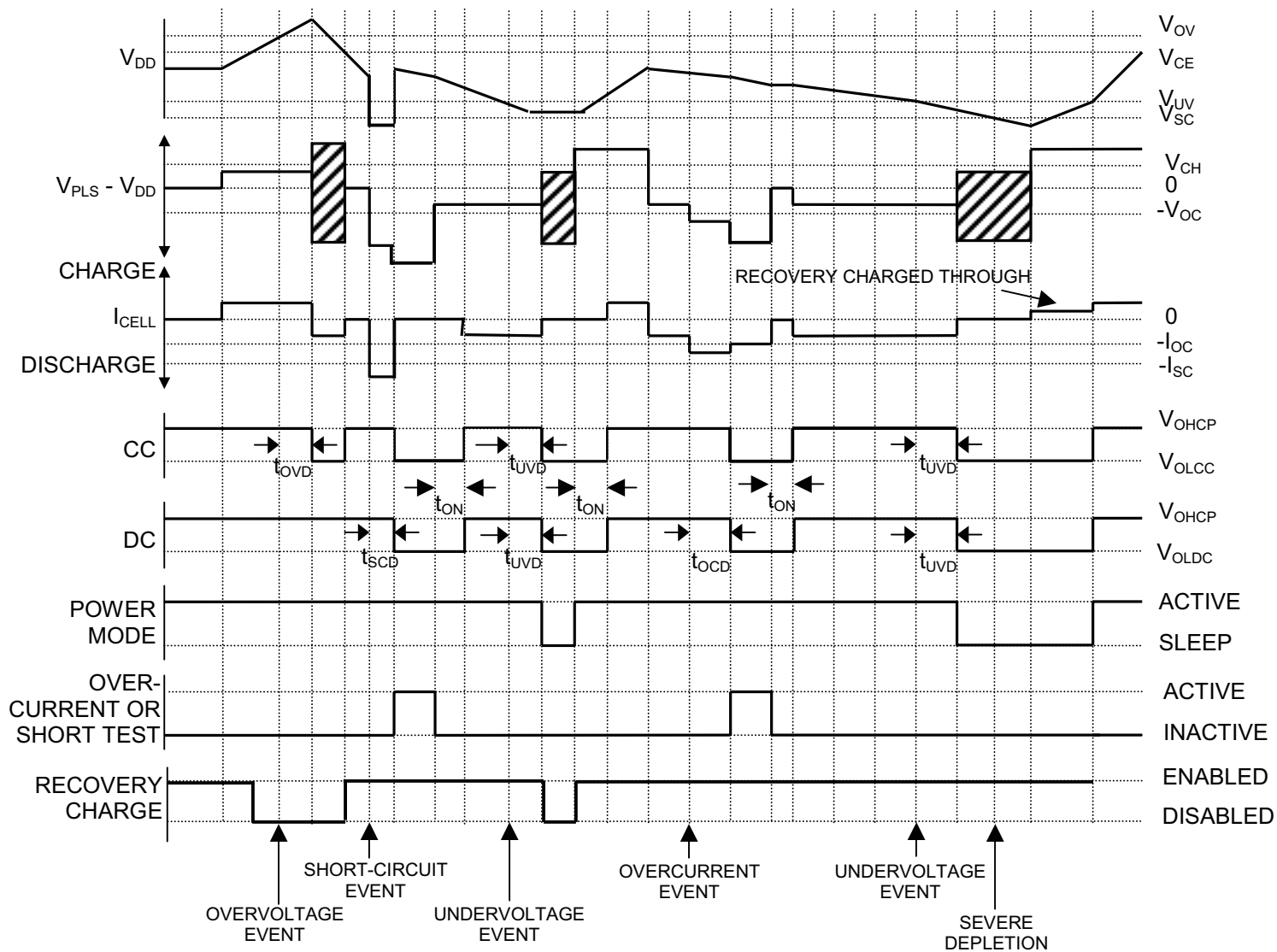

Notes:

I_{OC} = Current that produces a voltage drop across FETs equal to V_{OC} threshold.

I_{SC} = Current drawn from the battery during short-circuit event. (Collapses the cell terminal voltage to V_{SC} .)

Above example assumes FET on-resistance values such that the overcurrent threshold, V_{OC} , is reached before the short-circuit threshold, V_{SC} .

MEMORY

The DS27xx family of products is organized into a 256-byte linear address space with registers for instrumentation, status, and control in the lower 32 bytes, with lockable EEPROM memory occupying portions of the remaining address space. All EEPROM memory is general purpose except address 31h, which should be written with the default values for the status register.

EEPROM memory is shadowed by RAM to eliminate programming delays between writes and to allow the data to be verified by the host system before being copied to EEPROM. All reads and writes to/from EEPROM memory in fact access the shadow RAM. In unlocked EEPROM blocks, the write data command updates shadow RAM. In locked EEPROM blocks, the write data command is ignored. The copy data command copies the contents of shadow RAM to EEPROM in an unlocked block of EEPROM but has no effect on locked blocks. The recall data command copies the contents of a block of EEPROM to shadow RAM regardless of whether the block is locked or not.

Table 4. MEMORY MAP

ADDRESS (hex)	DESCRIPTION	READ/WRITE
00	Protection Register	R/W
01	Status Register	R
02–06	Reserved	—
07	EEPROM Register	R
08	Special Feature Register	R/W
09–1F	Reserved	—
20–23	EEPROM, Block 0	R/W ⁽¹⁾
24–2F	Reserved	—
30–33	EEPROM, Block 1 (31 = Status Register Initialization)	R/W ⁽¹⁾
34–FF	Reserved	—

(1) Each EEPROM block is read/write until locked by the LOCK command, after which it is read-only.

PROTECTION REGISTER

The protection register consists of flags that indicate protection circuit status and switches that give conditional control over the charging and discharging paths. Bits OV, UV, and DOC are set when corresponding protection conditions occur and remain set until cleared by the host system. The format of the protection register is shown in Figure 4. The function of each bit is described in detail in the following paragraphs.

Figure 4. PROTECTION REGISTER FORMAT

Address 00							
Bit 7	Bit 6	Bit 5	Bit 4	Bit 3	Bit 2	Bit 1	Bit 0
OV	UV	0	DOC	CC	DC	CE	DE

OV—Overvoltage Flag. When set to 1, this bit indicates the battery pack has experienced an overvoltage condition. This bit does not clear itself after the overvoltage state is corrected, and thus must be reset by the host system. A reset of this bit should be issued after the battery voltage falls below V_{CE} in order to detect future events. The OV bit is a volatile R/W bit, initialized to 0 upon power-on-reset (POR).

UV—Undervoltage Flag. When set to 1, this bit indicates the battery pack has experienced an undervoltage condition. This bit does not clear itself after the undervoltage state is corrected, and thus should be reset by the host system in order to detect future events. The UV bit is a volatile R/W bit, initialized to 1 upon POR.

DOC—Overcurrent Flag. When set to 1, this bit indicates the battery pack has experienced an overcurrent (or short-circuit) condition. This bit does not clear itself after the over/shortcurrent state is corrected, and thus should be reset by the host system in order to detect future events. The DOC bit is a volatile R/W bit, initialized to 1 upon POR.

CC—CC Pin Mirror. This read-only bit mirrors the state of the CC output pin. The CC bit is a 1 when the CC pin is driven high (V_{OHCC}). The CC bit is a 0 when the CC pin is driven low (V_{OLCC}).

DC—DC Pin Mirror. This read-only bit mirrors the state of the DC output pin. The DC bit is a 1 when the DC pin is driven high (V_{OHDC}). The DC bit is a 0 when the DC pin is driven low (V_{OLDLCC}).

CE—Charge Enable. Writing a 0 to this bit disables charging (CC output low, external charge FET off) regardless of cell or pack conditions. Writing a 1 to this bit enables charging, subject to override by the presence of any protection conditions. The DS2720 automatically sets this bit to 1 when it transitions from sleep mode to active mode. The CE bit is a volatile R/W bit, initialized to 1 upon POR.

DE—Discharge Enable. Writing a 0 to this bit disables discharging (DC output low, external discharge FET off) regardless of cell or pack conditions. Writing a 1 to this bit enables discharging, subject to override by the presence of any protection conditions. The DS2720 automatically sets this bit to 1 when it transitions from sleep mode to active mode. The DE bit is a volatile R/W bit, initialized to 1 upon POR.

STATUS REGISTER

The default values for the status register bits are stored in lockable EEPROM in the corresponding bits of address 31h. A recall data command for EEPROM block 1 recalls the default values into the status register bits. The format of the status register is shown in Figure 5. The function of each bit is described in detail in the following paragraphs.

Figure 5. STATUS REGISTER FORMAT

Address 01							
Bit 7	Bit 6	Bit 5	Bit 4	Bit 3	Bit 2	Bit 1	Bit 0
X	X	0	RNAOP	0	X	X	X

BIT 5—This bit is read only. The value of this bit is set by bit 5 of address 31h and is factory set to 0. The value of address 31h bit 5 must not be changed.

RNAOP—Read Net Address Opcode. A value of 0 in this bit sets the opcode for the read net address command to 33h, while a 1 sets the opcode to 39h. This bit is read-only. The desired default value should be set in bit 4 of address 31h. The factory default for RNAOP is 0.

BIT 3—This bit is read only. The value of this bit is set by bit 3 of address 31h and is factory set to 0. The value of address 31h bit 3 must not be changed.

X—Reserved Bits.

EEPROM REGISTER

The format of the EEPROM register is shown in Figure 6. The function of each bit is described in detail in the following paragraphs.

Figure 6. EEPROM REGISTER FORMAT

Address 07							
Bit 7	Bit 6	Bit 5	Bit 4	Bit 3	Bit 2	Bit 1	Bit 0
EEC	LOCK	X	X	X	X	BL1	BL0

EEC—EEPROM Copy Flag. A 1 in this read-only bit indicates that a copy data command is in progress. While this bit is high, writes to EEPROM addresses are ignored. A 0 in this bit indicates that data can be written to unlocked EEPROM blocks if the DS2720 is in the active mode of operation.

LOCK—EEPROM Lock Enable. When this bit is 0, the lock command is ignored. Writing a 1 to this bit enables the lock command. After the lock command is executed, the LOCK bit is reset to 0. The LOCK bit is a volatile R/W bit, initialized to 0 upon POR.

BL1—EEPROM Block 1 Lock Flag. A 1 in this read-only bit indicates that EEPROM block 1 (addresses 30 to 33h) is locked (read-only) while a 0 indicates block 1 is unlocked (read/write).

BL0—EEPROM Block 0 Lock Flag. A 1 in this read-only bit indicates that EEPROM block 0 (addresses 20 to 23h) is locked (read-only) while a 0 indicates block 0 is unlocked (read/write).

X—Reserved Bits.

SPECIAL FEATURE REGISTER

The format of the special feature register is shown in Figure 7. The function of each bit is described in detail in the following paragraphs.

Figure 7. SPECIAL FEATURE REGISTER FORMAT

Address 08							
Bit 7	Bit 6	Bit 5	Bit 4	Bit 3	Bit 2	Bit 1	Bit 0
PSF	X	X	X	X	X	X	OT

PSF— $\overline{\text{PS}}$ Flag. This bit is reset to 0 when the DS2720 detects the $\overline{\text{PS}}$ pin is pulled to V_{SS} . This bit does not set itself to a 1 after the $\overline{\text{PS}}$ pin returns to a high logic level, and thus must be set by the host system to detect future events. This bit is initialized to a 1 upon POR.

OT—Overtemperature Flag. When set to 1, this bit indicates the battery pack has experienced an overtemperature condition. This bit does not clear itself after the overtemperature state is corrected, and thus must be reset by the host system after the temperature decreases below T_{MAX} to re-enable the charge and discharge FETs. Writing a 1 to this bit disables the FETs, but this is not recommended. The OT bit is a volatile R/W bit, initialized to 0 upon POR.

X—Reserved Bits.

$\overline{\text{PS}}$ INPUT PIN

The $\overline{\text{PS}}$ pin is internally pulled to V_{DD} through a high-value resistance. $\overline{\text{PS}}$ is continuously monitored for a low-impedance connection to V_{SS} . Connecting $\overline{\text{PS}}$ to V_{SS} wakes up the DS2720 if it was in sleep mode. If the DS2720 was in active mode, $\overline{\text{PS}}$ has no effect.

1-WIRE BUS SYSTEM

The 1-Wire bus is a system that has a single bus master and one or more slaves. A multidrop bus is a 1-Wire bus with multiple slaves. A single-drop bus has only one slave device. In all instances, the DS2720 is a slave device. The bus master is typically a microprocessor in the host system. The discussion of this bus system consists of four topics: 64-bit net address, hardware configuration, transaction sequence, and 1-Wire signaling.

64-BIT NET ADDRESS

Each DS2720 has a unique, factory-programmed 1-Wire net address that is 64 bits in length. The first eight bits are the 1-Wire family code (31h for DS2720). The next 48 bits are a unique serial number. The last eight bits are a CRC of the first 56 bits (see Figure 8). The 64-bit net address and the 1-Wire I/O circuitry built into the device enable the DS2720 to communicate through the 1-Wire protocol detailed in the *1-Wire Bus System* section of this data sheet.

Figure 8. 1-WIRE NET ADDRESS FORMAT

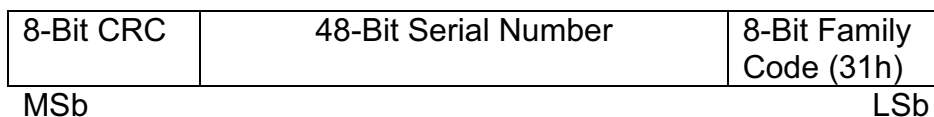

CRC GENERATION

The DS2720 has an 8-bit cyclic redundancy check (CRC) stored in the most significant byte of its 1-Wire net address. To ensure error-free transmission of the address, the host system can compute a CRC value from the first 56 bits of the address and compare it to the CRC from the DS2720. The host system is responsible for verifying the CRC value and taking action as a result. The DS2720 does not compare CRC values and does not prevent a command sequence from proceeding as a result of a CRC mismatch. Proper use of the CRC can result in a communication channel with a very high level of integrity.

The CRC can be generated by the host using a circuit consisting of a shift register and XOR gates as shown in Figure 9, or it can be generated in software. Additional information about the Dallas 1-Wire CRC is available in Application Note 27, *Understanding and Using Cyclic Redundancy Checks with Dallas Semiconductor Touch Memory Products*.

In the circuit in Figure 9, the shift register bits are initialized to 0. Then, starting with the least significant bit of the family code, one bit at a time is shifted in. After the 8th bit of the family code has been entered, then the serial number is entered. After the 48th bit of the serial number has been entered, the shift register contains the CRC value.

Figure 9. 1-WIRE CRC GENERATION BLOCK DIAGRAM

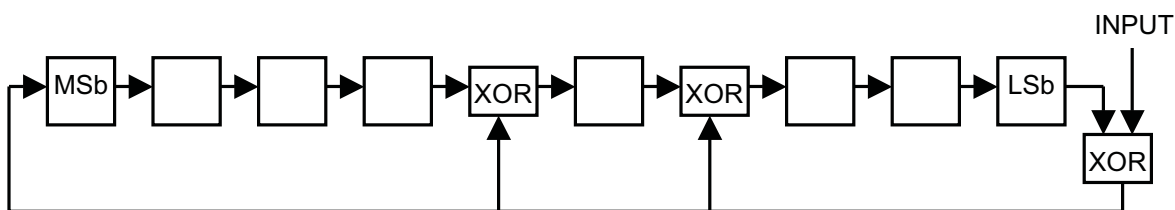

HARDWARE CONFIGURATION

Because the 1-Wire bus has only a single line, it is important that each device on the bus be able to drive it at the appropriate time. To facilitate this, each device attached to the 1-Wire bus must connect to the bus with open-drain or tri-state output drivers. The DS2720 uses an open-drain output driver as part of the bidirectional interface circuitry shown in Figure 10. If a bidirectional pin is not available on the bus master, separate output and input pins can be connected together.

The 1-Wire bus must have a pullup resistor at the bus-master end of the bus. For short line lengths, the value of this resistor should be approximately 5kΩ. The idle state for the 1-Wire bus is high. If, for any reason, a bus transaction must be suspended, the bus must be left in the idle state in order to properly resume the transaction later. If the bus is left low for more than 120μs, slave devices on the bus begin to interpret the low period as a reset pulse, effectively terminating the transaction.

Figure 10. 1-WIRE BUS INTERFACE CIRCUITRY

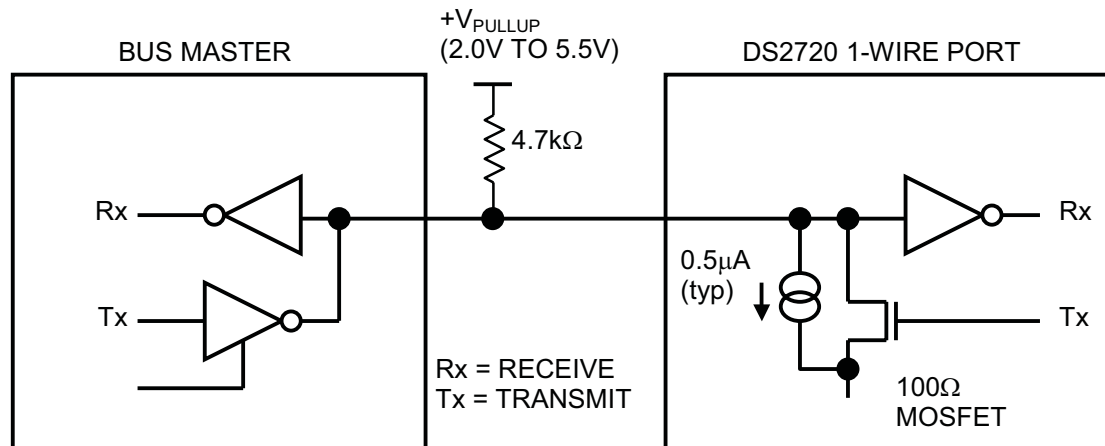

TRANSACTION SEQUENCE

The protocol for accessing the DS2720 through the 1-Wire port is as follows:

- Initialization
- Net Address Command
- Function Command
- Transaction/Data

The sections that follow describe each of these steps in detail.

All transactions of the 1-Wire bus begin with an initialization sequence consisting of a reset pulse transmitted by the bus master followed by a presence pulse simultaneously transmitted by the DS2720 and any other slaves on the bus. The presence pulse tells the bus master that one or more devices are on the bus and ready to operate. For more details, see the *1-Wire Signaling* section.

NET ADDRESS COMMANDS

Once the bus master has detected the presence of one or more slaves, it can issue one of the ROM commands described in the following paragraphs. The name of each net address command is followed by the 8-bit opcode for that command in square brackets. Figure 11 presents a transaction flowchart of the ROM commands.

Read Net Address [33h or 39h]. This command allows the bus master to read the DS2720's 1-Wire net address. This command can only be used if there is a single slave on the bus. If more than one slave is present, a data collision occurs when all slaves try to transmit at the same time (open drain produces a wired-AND result). The RNAOP bit in the status register selects the opcode for this command, with RNAOP = 0 indicating 33h and RNAOP = 1 indicating 39h.

Match Net Address [55h]. This command allows the bus master to specifically address one DS2720 on the 1-Wire bus. Only the addressed DS2720 responds to any subsequent function command. All other slave devices ignore the function command and wait for a reset pulse. This command can be used with one or more slave devices on the bus.

Skip Net Address [CCh]. This command saves time when there is only one 1-Wire device on the bus by allowing the bus master to issue a function command without specifying the address of the slave. If more than one slave device is present on the bus, a subsequent function command can cause a data collision when all slaves transmit data at the same time.

Search Net Address [F0h]. This command allows the bus master to use a process of elimination to identify the 1-Wire net addresses of all slave devices on the bus. The search process involves the repetition of a simple three-step routine: read a bit, read the complement of the bit, then write the desired value of that bit. The bus master performs this simple three-step routine on each bit location of the net address. After one complete pass through all 64 bits, the bus master knows the address of one device. The remaining devices can then be identified on additional iterations of the process. See Chapter 5 of the *Book of DS19xx iButton® Standards* for a comprehensive discussion of a net address search, including an actual example.

Resume Command [A5H]. In a typical application the DS2720 can be accessed several times to complete control adjustment. To maximize data throughput in a multidrop environment, the resume command has been implemented. This function checks the status of an internal flag. If it is set, it directly transfers control in similar fashion to the skip net address command. The only way to set the internal flag is through successfully executing the match net address or search net address. Once the flag has been set, the device can be repeatedly accessed through the resume command. Accessing another device on the bus clears the flag, thus preventing two or more devices from simultaneously responding to the resume command function.

FUNCTION COMMANDS

After successfully completing one of the net address commands, the bus master can access the features of the DS2720 with any of the function commands described in the following paragraphs. The name of each function is followed by the 8-bit opcode for that command in square brackets. The function commands are summarized in Table 5.

Read Data [69h, XX]. This command reads data from the DS2720 starting at memory address XX. The LSb of the data in address XX is available to be read immediately after the MSb of the address has been entered. Because the address is automatically incremented after the MSb of each byte is received, the LSb of the data at address XX + 1 is available to be read immediately after the MSb of the data at address XX. If the bus master continues to read beyond address FFh, data is read starting at memory address 00 and the address is automatically incremented until a reset pulse occurs. Addresses labeled “Reserved” in the memory map contain undefined data. The read data command can be terminated by the bus master with a reset pulse at any bit boundary.

Write Data [6Ch, XX]. This command writes data to the DS2720 starting at memory address XX. The LSb of the data to be stored at address XX can be written immediately after the MSb of address has been entered. Because the address is automatically incremented after the MSb of each byte is written, the LSb to be stored at address XX + 1 can be written immediately after the MSb to be stored at address XX. If the bus master continues to write beyond address FFh, the data starting at address 00 is overwritten. Writes to read-only addresses, reserved addresses and locked EEPROM blocks are ignored. Incomplete bytes are not written. Writes to unlocked EEPROM blocks are to shadow RAM rather than EEPROM. See the *Memory* section for more details.

Copy Data [48h, XX]. This command copies the contents of shadow RAM to EEPROM for the 4-byte EEPROM block containing address XX. Copy data commands that address locked blocks are ignored. While the copy data command is executing, the EEC bit in the EEPROM register is set to 1 and writes to

EEPROM addresses are ignored. Reads and writes to non-EEPROM addresses can still occur while the copy is in progress. The copy data command takes t_{EEC} time to execute, starting on the next falling edge after the address is transmitted. The copy data command is ignored by the DS2720 while in the sleep mode.

Recall Data [B8h, XX]. This command recalls the contents of the 4-byte EEPROM block containing address XX to shadow RAM.

Lock [6Ah, XX]. This command locks (write-protects) the 4-byte block of EEPROM memory containing memory address XX. The LOCK bit in the EEPROM register must be set to 1 before the lock command is executed. To help prevent unintentional locks, one must issue the lock command immediately after setting the LOCK bit (EEPROM register, address 07h, bit 06) to a 1. If the LOCK bit is 0 or if setting the lock bit to 1 does not immediately precede the lock command, the lock command has no effect. The lock command is permanent; a locked block can never be written again. The lock command is ignored by the DS2720 while in the sleep mode.

Table 5. FUNCTION COMMANDS

COMMAND	DESCRIPTION	COMMAND PROTOCOL	BUS STATE AFTER COMMAND PROTOCOL	BUS DATA
Read Data	Reads data from memory starting at address XX	69h, XX	Master Rx	Up to 256 bytes of data
Write Data	Writes data to memory starting at address XX	6Ch, XX	Master Tx	Up to 256 bytes of data
Copy Data	Copies shadow RAM data to EEPROM block containing address XX	48h, XX	Master Reset	None
Recall Data	Recalls EEPROM block containing address XX to RAM	B8h, XX	Master Reset	None
Lock	Permanently locks the block of EEPROM containing address XX	6Ch, 07h, 4Xh 6Ah, XX	Master Reset	None

Figure 11. NET ADDRESS COMMAND FLOW CHART

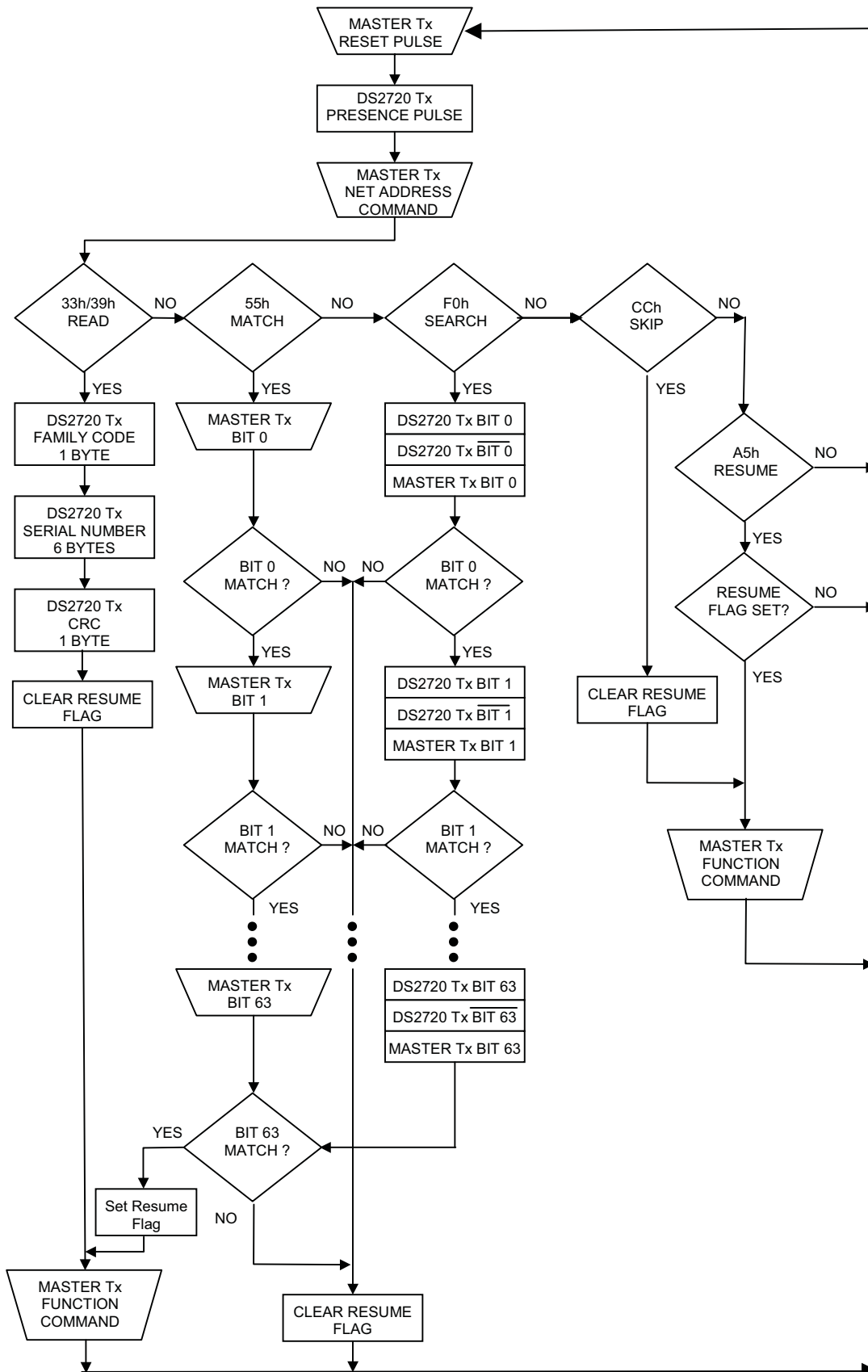

I/O SIGNALING

The 1-Wire bus requires strict signaling protocols to insure data integrity. The four protocols used by the DS2720 are the initialization sequence (reset pulse followed by presence pulse), write 0, write 1, and read data. All of these types of signaling except the presence pulse are initiated by the bus master.

The initialization sequence required to begin any communication with the DS2720 is shown in Figure 12. A presence pulse following a reset pulse indicates the DS2720 is ready to accept a net address command. The bus master transmits (Tx) a reset pulse for t_{RSTL} . The bus master then releases the line and goes into receive mode (Rx). The 1-Wire bus line is then pulled high by the pullup resistor. After detecting the rising edge on the DQ pin, the DS2720 waits for t_{PDH} and then transmits the presence pulse for t_{PDL} .

Figure 12. 1-WIRE INITIALIZATION SEQUENCE

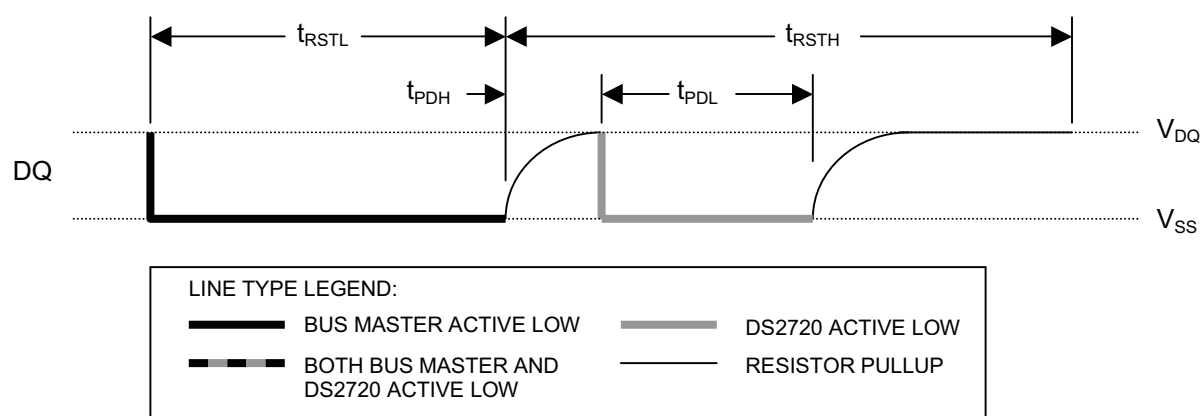

WRITE-TIME SLOTS

A write-time slot is initiated when the bus master pulls the 1-Wire bus from a logic-high (inactive) level to a logic-low level. There are two types of write-time slots: write 1 and write 0. All write-time slots must be t_{SLOT} (60 μ s to 120 μ s) in duration with a 1 μ s minimum recovery time, t_{REC} , between cycles. The DS2720 samples the 1-Wire bus line between 15 μ s and 60 μ s after the line falls. If the line is high when sampled, a write 1 occurs. If the line is low when sampled, a write 0 occurs (see Figure 13). For the bus master to generate a write 1 time slot, the bus line must be pulled low and then released, allowing the line to be pulled high within 15 μ s after the start of the write time slot. For the host to generate a write 0 time slot, the bus line must be pulled low and held low for the duration of the write-time slot.

READ-TIME SLOTS

A read-time slot is initiated when the bus master pulls the 1-Wire bus line from a logic-high level to a logic-low level. The bus master must keep the bus line low for at least 1 μ s and then release it to allow the DS2720 to present valid data. The bus master can then sample the data t_{RDV} (15 μ s) from the start of the read-time slot. By the end of the read-time slot, the DS2720 releases the bus line and allows it to be pulled high by the external pullup resistor. All read-time slots must be t_{SLOT} (60 μ s to 120 μ s) in duration with a 1 μ s minimum recovery time, t_{REC} , between cycles. See Figure 13 for more information.

Figure 13. 1-WIRE WRITE- AND READ-TIME SLOTS

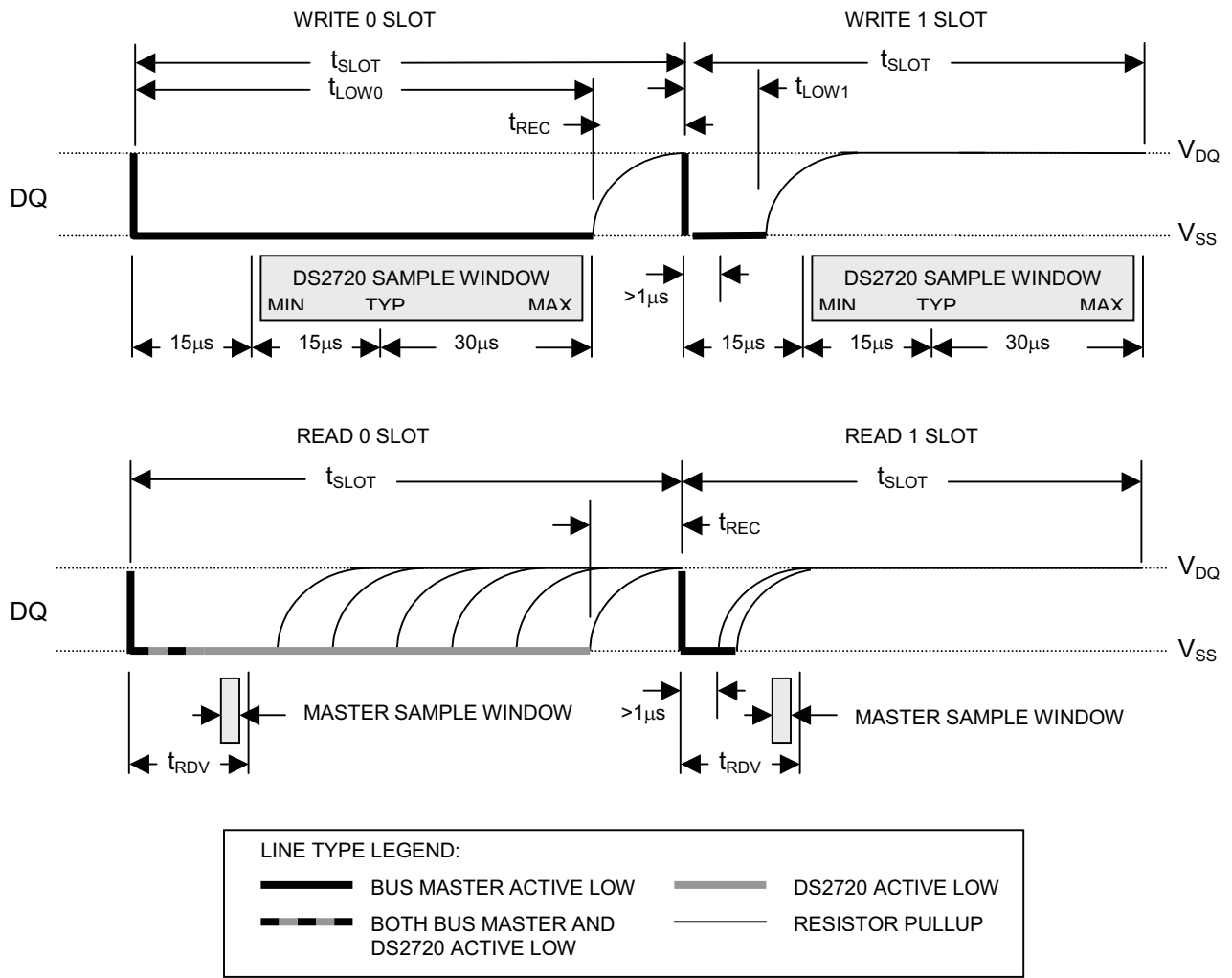

ABSOLUTE MAXIMUM RATINGS*

Voltage on PLS, Relative to V_{SS}	-0.3V to +18V
Voltage on CC, DC, and CP Pins, Relative to V_{SS}	-0.3V to +12V
Voltage on any Other Pin, Relative to V_{SS}	-0.3V to +6V
Operating Temperature Range	-40°C to +85°C
Storage Temperature Range	-55°C to +125°C
Soldering Temperature	See IPC/JEDEC-STD-020A

* This is a stress rating only and functional operation of the device at these or any other conditions above those indicated in the operation sections of this specification is not implied. Exposure to absolute maximum rating conditions for extended periods of time may affect reliability.

RECOMMENDED DC**OPERATING CONDITIONS**(-20°C to +70°C, $2.5V \leq V_{DD} \leq 5.5V$)

PARAMETER	SYMBOL	CONDITIONS	MIN	TYP	MAX	UNITS	NOTES
Supply Voltage	V_{DD}		2.5		5.5	V	1
Data Pin	DQ		-0.3		5.5	V	1

DC ELECTRICAL CHARACTERISTICS(-20°C to +70°C, $2.5V \leq V_{DD} \leq 4.5V$)

PARAMETER	SYMBOL	CONDITIONS	MIN	TYP	MAX	UNITS	NOTES
Active Current	I_{ACTIVE}	DQ = V_{DD} $0^{\circ}C \leq T_A \leq 50^{\circ}C$		12.5	20	μA	2
		DQ = V_{DD}			25	μA	2
Sleep Mode Current	I_{SLEEP}	DQ = 0V, \overline{PS} floating		1.5	2.5	μA	
Input Logic High: DQ	V_{IH1}		1.5			V	1
Input Logic High: \overline{PS}	V_{IH2}		$V_{DD} - 0.2V$			V	1, 6
Input Logic Low: DQ	V_{IL1}				0.4	V	1
Input Logic Low: \overline{PS}	V_{IL2}				0.2	V	1
Output Logic High: CC, DC	V_{OHCP}	$R_{LOAD} > 10M\Omega$	8.5	9.0	9.5	V	1
Output Logic Low: CC	V_{OLCC}	$R_{LOAD} > 10M\Omega$		V_{DD}	$V_{DD} + 0.1$	V	1
Output Logic Low: DC	V_{OLDC}	$R_{LOAD} > 10M\Omega$ $V_{PLS} \leq 10V$		V_{PLS}	$V_{PLS} + 0.1$	V	1, 7
Output Logic Low: DQ	V_{OL1}	$I_{OL} = 4mA$			0.4	V	1
DQ Input Pulldown Current	I_{PD}	$V_{DQ} = 0.4V$	0.1	0.5	2.5	μA	
\overline{PS} Pullup Current	I_{PS}	$V_{PS} = 0.4V$		100		nA	
CC Pulldown Resistance	R_{CCPD}			1.2	4	k Ω	
DC Pulldown Resistance	R_{DCPD}			12	16	k Ω	

**ELECTRICAL CHARACTERISTICS:
PROTECTION CIRCUITRY**
 $(0^{\circ}\text{C to } +50^{\circ}\text{C}, 2.5\text{V} \leq V_{\text{DD}} \leq 4.5\text{V})$

PARAMETER	SYMBOL	MIN	TYP	MAX	UNITS	NOTES
Overvoltage Detect	V_{OVA}	4.250	4.275	4.300	V	1, 3
	V_{OVB}	4.325	4.350	4.375		
	V_{OVC}	4.275	4.300	4.325		
Charge Enable	V_{CE}	Typ - 75mV	$V_{\text{OV}}/1.022$	Typ + 75mV	V	1, 3
Undervoltage Detect	V_{UV}	Typ - 120mV	$V_{\text{OV}}/1.55$	Typ + 120mV	V	1, 3
Overtemperature Detect	T_{MAX}	70	90	110	$^{\circ}\text{C}$	3
Overcurrent Detect	V_{OC}	140	200	260	mV	1, 3
Short-Circuit Detect	V_{SC}	2.0	2.3	2.6	V	1
Overvoltage Delay	t_{OVD}	0.75	1.0	1.25	s	3
Undervoltage Delay	t_{UVD}	90	125	160	ms	3
Overcurrent Delay	t_{OCD}	12	16	20	ms	3
Short-Circuit Delay	t_{SCD}	50	100	150	μs	
Test Resistance, I_{TST} Active	R_{TST1}	3		11	k Ω	5
Test Resistance, Recovery Charging	R_{TST2}	5		15	k Ω	5
Charger Detect Voltage	V_{CH}	20	60	120	mV	

ELECTRICAL CHARACTERISTICS:
1-WIRE INTERFACE
 $(-20^{\circ}\text{C to } +70^{\circ}\text{C}, 2.5\text{V} \leq V_{\text{DD}} \leq 5.5\text{V})$

PARAMETER	SYMBOL	MIN	TYP	MAX	UNITS	NOTES
Time Slot	t_{SLOT}	60		120	μs	
Recovery Time	t_{REC}	1			μs	
Write 0 Low Time	t_{LOW0}	60		120	μs	
Write 1 Low Time	t_{LOW1}	1		15	μs	
Read Data Valid	t_{RDV}			15	μs	
Reset Time High	t_{RSTH}	480			μs	
Reset Time Low	t_{RSTL}	480		960	μs	
Presence Detect High	t_{PDH}	15		60	μs	
Presence Detect Low	t_{PDL}	60		240	μs	
Active Transition to CC/DC Engage	t_{ON}			100	ms	4
DQ Capacitance	C_{DQ}			25	pF	

EEPROM RELIABILITY**SPECIFICATION:**(-20°C to +70°C, $2.5V \leq V_{DD} \leq 5.5V$)



PARAMETER	SYMBOL	MIN	TYP	MAX	UNITS	NOTES
Copy to EEPROM Time	t_{EEC}		1	5	ms	
EEPROM Copy Endurance	N_{EEC}	25,000			cycles	
EEPROM Data Retention	t_{EEDR}	4			years	

NOTES

1. All voltages are referenced to V_{SS} .
2. Specified with no resistive load on CC, DC, or CP.
3. Contact the factory for different voltage trip points and delay periods.
4. Typical load capacitance on CC, DC is 1000pF CP (charge pump reservoir cap) = 0.1 μ F. DC load total on CC, DC, CP > 10M Ω .
5. $R_{TST} = |V_{PLS} - V_{DD}| / I$ measured, with $V_{PLS} = 3.2V$, $V_{DD} = 3.6V$ when test current, I_{TST} , active for R_{TST1} ; and $V_{PLS} = 4.0V$, $V_{DD} = 2.5V$ when recovery charging for R_{TST2} .
6. Maximum high-to-low fall time is 5 μ s.
7. Internal 10V clamp on DC pin limits DC output logic low when $PLS > 10V$
8. Short-circuit delay tested with V_{DD} ramped from 3.1V to 1.9V in 5 μ s. Delay measured from $V_{DD} = 2.5V$ to DC pin fall to 7V from V_{OHCP} .

Looking for pricing, stock, or lifecycle information?

Click below to explore more details on WIN SOURCE:

-  [View DS2720BU+T&R on WIN SOURCE](#)
-  [Maxim Integrated Information](#)

Optimize Your Supply Chain with WIN SOURCE Solutions

-  Global Sourcing Solution
-  Obsolete Management
-  Cost Control Management
-  Shortage Management
-  Alternative Solution
-  Excess Inventory Management